



Standard Practice for Electromagnetic (Eddy-Current) Examination of Nickel and Nickel Alloy Tubular Products¹

This standard is issued under the fixed designation E571; the number immediately following the designation indicates the year of original adoption or, in the case of revision, the year of last revision. A number in parentheses indicates the year of last reapproval. A superscript epsilon (ϵ) indicates an editorial change since the last revision or reapproval.

1. Scope*

1.1 This practice² covers the procedures for eddy-current examination of nickel and nickel alloy tubes. These procedures are applicable for tubes with outside diameters up to 2 in. (50.8 mm), incl, and wall thicknesses from 0.035 to 0.120 in. (0.889 to 3.04 mm), incl. These procedures may be used for tubes beyond the size range recommended, by contractual agreement between the purchaser and the producer.

1.2 The procedures described in this practice make use of fixed encircling test coils or probe systems.

1.3 *Units*—The values stated in inch-pound units are to be regarded as standard. The values given in parentheses are mathematical conversions to SI units that are provided for information only and are not considered standard.

NOTE 1—For convenience, the term “tube” or “tubular product” will hereinafter be used to refer to both pipe and tubing.

1.4 *This standard does not purport to address all of the safety concerns, if any, associated with its use. It is the responsibility of the user of this standard to establish appropriate safety and health practices and determine the applicability of regulatory limitations prior to use.*

2. Referenced Documents

2.1 ASTM Standards:³

[E309 Practice for Eddy-Current Examination of Steel Tubular Products Using Magnetic Saturation](#)

[E543 Specification for Agencies Performing Nondestructive Testing](#)

[E1316 Terminology for Nondestructive Examinations](#)

¹ This practice is under the jurisdiction of ASTM Committee E07 on Nondestructive Testing and is the direct responsibility of Subcommittee E07.07 on Electromagnetic Method.

Current edition approved Aug. 1, 2012. Published September 2012. Originally approved in 1976. Last previous edition approved in 2007 as E571 - 98(2007). DOI: 10.1520/E0571-12.

² For ASME Boiler and Pressure Vessel Code applications see related Practice SE-571 in Section II of that Code.

³ For referenced ASTM standards, visit the ASTM website, www.astm.org, or contact ASTM Customer Service at service@astm.org. For *Annual Book of ASTM Standards* volume information, refer to the standard's Document Summary page on the ASTM website.

2.2 Other Documents:

[SNT-TC-1A Recommended Practice for Personnel Qualification and Certification in Nondestructive Testing](#)⁴

[ANSI/ASNT-CP-189 ASNT Standard for Qualification and Certification of Nondestructive Testing Personnel](#)⁴

[NAS-410 Certification and Qualification of Nondestructive Personnel \(Quality Assurance Committee\)](#)⁵

3. Terminology

3.1 Standard terminology relating to electromagnetic testing may be found in Terminology E1316, Section C, Electromagnetic Testing.

4. Summary of Practice

4.1 Examination is usually performed by the use of one of two general techniques:

4.1.1 *Encircling Coil Technique*—Examination is performed by passing the tube lengthwise through a coil energized with alternating current at one or more frequencies. See Fig. 1. The electrical impedance of the coil is modified by the proximity of the tube, the tube dimensions, electrical conductivity, saturating magnetic field, magnetic permeability, and metallurgical or mechanical discontinuities in the tube. As the tube passes through the coil, the changes in electromagnetic response caused by these variables in the tube change the coil impedance, which activates an audible or visual signaling device or a mechanical marker.

4.1.2 *Probe Coil Technique*—Probe coils are positioned in close proximity to the outside diameter or to the inside diameter, or to both diameter surfaces, of the tubular product being examined as shown in Fig. 1. Since the probe is generally small and does not encircle the tube, it examines only a limited area in the vicinity of the probe. When required to examine the entire volume of the tubular product, it is common practice to rotate either the tubular product or the probe around the tube. Frequently, in the case of welded tubular products, only the weld is examined by scanning along the weld zone. In the case

⁴ Available from American Society for Nondestructive Testing (ASNT), P.O. Box 28518, 1711 Arlingate Ln., Columbus, OH 43228-0518, <http://www.asnt.org>.

⁵ Available from Aerospace Industries Association of America, Inc. (AIA), 1000 Wilson Blvd., Suite 1700, Arlington, VA 22209-3928, <http://www.aia-aerospace.org>.

*A Summary of Changes section appears at the end of this standard

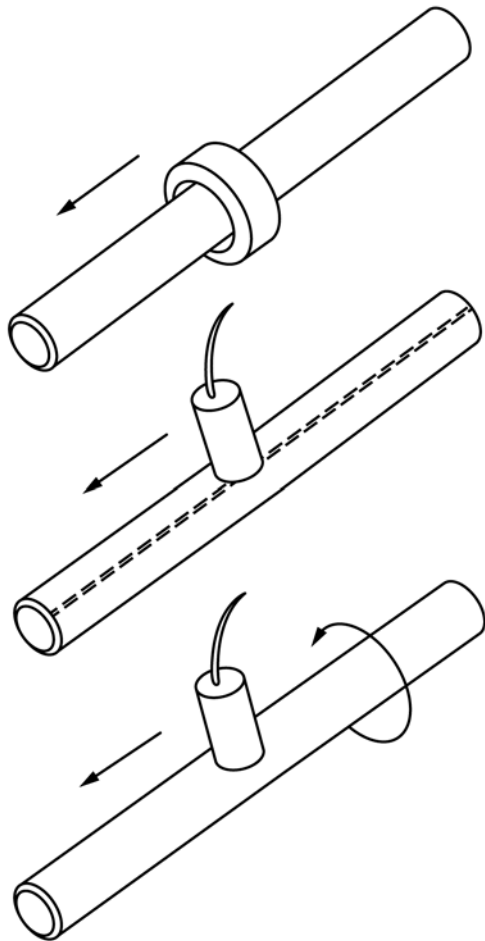

FIG. 1 Encircling-Coil and Probe-Coil Techniques for Electromagnetic Examination of Tubular Products

ity can mask the signals resulting from small imperfections. A magnetic saturation technique can be used to reduce this interference to an acceptable level.

5. Significance and Use

5.1 Eddy-current testing is a nondestructive method of locating discontinuities in metallic materials. Signals can be produced by discontinuities originating on either the external or internal surfaces of the tube or by discontinuities totally contained within the wall. Since the density of eddy currents decreases nearly exponentially with increasing distance from the surface nearest the coil, the response to deep-seated defects decreases correspondingly. Phase changes are also associated with changes in depth, allowing the use of phase analysis techniques.

5.2 The response from natural discontinuities can be significantly different than that from artificial discontinuities, such as drilled holes or notches. For this reason, sufficient work should be done to establish the sensitivity level and setup required to detect natural discontinuities of consequence to the end use of the product.

5.3 Some indications obtained by this method may not be relevant to product quality; for example, an irrelevant indication may be caused by minute dents or tool chatter marks, which are not detrimental to the end use of the product. Irrelevant indications can mask unacceptable discontinuities. Relevant indications are those which result from discontinuities. Any indication that exceeds the rejection level shall be treated as a relevant indication until it can be demonstrated that it is irrelevant.

5.4 Generally, eddy-current examination systems are not sensitive to discontinuities adjacent to the ends of the tube (end effect).

5.5 Discontinuities such as scratches or seams that are continuous and uniform over the full length of the tube may not always be detected with differential encircling coils or probes scanned along the tube length.

5.6 For material that is magnetic, a strong magnetic field shall be placed in the region of the examining coil. A magnetic field may also be used to improve the signal-to-noise ratio in tubing that exhibits slight residual magnetism.

6. Basis of Application

6.1 The following criteria may be specified in the purchase specification contractual agreement, or elsewhere, and may require agreement between the purchaser and the supplier.

6.1.1 Acceptance criteria.

6.1.2 Type, dimensions, and number of artificial discontinuities to be placed in the reference standard.

6.1.3 Extent of examination; that is, full circumference of outside or inside diameter, or both, or weld only, if welded.

6.1.4 Operator qualifications, if required (see 6.1.6 below).

6.1.5 Standardization intervals.

6.1.6 If specified in the contractual agreement, personnel performing examinations to this practice shall be qualified in accordance with a nationally recognized NDT personnel qualification practice or standard such as ANSI/ASNT-CP-189,

where the tubular products are joined by welding and the probe is rotated, the probe is orbited about the central axis of the tube such that a circumferential examination of the tube and/or weld may be made. The depth of penetration of the interrogating magnetic fields into the tubular product may be smaller for this type of probe coil compared to the encircling coil.

4.2 The magnetic permeability of magnetic materials severely limits the depth of penetration of induced eddy currents. Furthermore, the permeability variations inherent in magnetic tubular products can cause spurious test results. A useful solution to this problem involves the application of a strong external magnetic field in the region of the examining coil or probe. This technique, known as magnetic saturation, causes a magnetic material to exhibit sufficiently small magnetic characteristics of permeability, hysteresis, etc., so that the material under examination is effectively rendered nonmagnetic. When achieved, this condition allows an eddy-current system to measure and detect electrical resistivity and geometrical variations (including defects) independent of concurrent variations in magnetic properties.

NOTE 2—Practice E309 may be used for strongly magnetic materials.

4.2.1 During the examination of slightly magnetic tubing the signals resulting from the variation of magnetic permeabil-

SNT-TC-1A, NAS-410, ASNT-ACCP, or a similar document and certified by the certifying agency as applicable. The practice or standard used and its applicable revision shall be identified in the contractual agreement between the using parties.

NOTE 3—MIL-STD-410 is canceled and has been replaced with NAS-410, however, it may be used with agreement between contracting parties.

6.1.7 If specified in the contractual agreement, NDT agencies shall be qualified and evaluated in accordance with Specification E543. The applicable edition of Specification E543 shall be specified in the contractual agreement.

7. Apparatus

7.1 *Electronic Apparatus*—The electronic apparatus shall be capable of energizing the encircling coils or probes with alternating current of suitable frequencies and shall be capable of sensing changes in impedance of the encircling coils or probes. Equipment may include any appropriate signal processing circuits such as a phase discriminator, filter circuits, etc., as required for the particular application.

7.2 *Encircling Coil Assembly*—The encircling coil assembly shall consist of one or more electrical coils which encircle the article being examined. The inside geometry of the coils should closely approximate the surface geometry of the specimen so that when the specimen is passed through the coils all points on the outer circumference of the specimen are effectively equidistant from, and in close proximity to, the inner surfaces of the examining coils.

7.3 *Probe Assembly*—The probe coil assembly normally contains an exciting coil and a sensor, although in some cases the exciter and the sensor are one and the same. The sensor may consist of one or more electrical coils or a semiconductor device that responds to variations in electromagnetic flux density. Good examination practices require that the spacing between the probe coil assembly and the tube being examined be both small and uniform.

7.4 *Driving Mechanism*—The mechanical device capable of passing the tube through the examining coil or past the probe shall operate at a uniform speed with minimum vibration of coil, probe, or tube and shall maintain the article being examined in proper register or concentricity with the probe or coil. Where required, the mechanism shall be capable of rotating the tube or probe with a uniform rotational speed.

8. Reference Standard

8.1 The standard used to adjust the sensitivity of the apparatus shall be free of interfering discontinuities and of the same nominal alloy, temper, and nominal dimensions as the lot of tubes to be examined on a production basis. It shall be of sufficient length to permit the spacing of artificial discontinuities to provide good signal resolution, and to be mechanically stable while in the examining position in the apparatus. Artificial discontinuities placed in the tube shall be of the following types (see Fig. 2):

8.1.1 *Notch*—Longitudinal or transverse notches, or both, may be produced by milling, filing, EDM (Electric Discharge

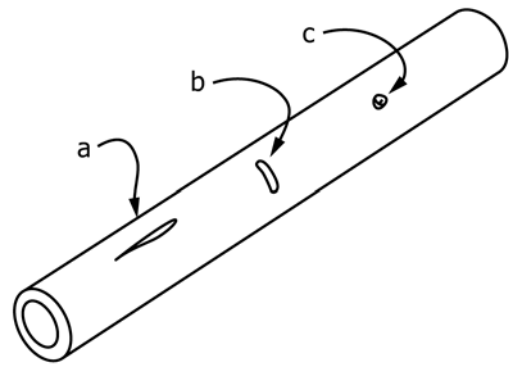

- a = longitudinal notch (milled or EDM)
- b = transverse notch (milled, filed, or EDM)
- c = drilled hole (radially through one wall)

FIG. 2 Various Types of Artificial Discontinuities

Machine) or other suitable means. Notches may be placed on the outer, inner, or both surfaces of the reference standard.

NOTE 4—Longitudinal notch standards are normally used when examining with rotating probe systems.

8.1.2 *Hole*—The holes shall be drilled radially partially or completely through the tube wall without causing permanent distortion of the tube wall.

8.1.3 Hole size and notch configuration (type, orientation, length, depth, size, etc.) influence the eddy-current response. These factors, plus the method and tolerances used in their measurement, shall be as specified in the agreement between the supplier and the purchaser.

9. Adjustment and Standardization of Apparatus Sensitivity

9.1 Select the apparatus, examining frequency, coil or probe configuration or both, magnetic saturation system if used, phase discrimination, and other circuitry, as well as speed of examination. Demonstrate the system capability for detecting artificial discontinuities of the size and type of interest at production speed.

9.2 Fabricate the applicable reference standard in accordance with the agreement between the purchaser and the tubing supplier. Discard and replace the tube used as the reference standard when erroneous signals are produced from mechanical, metallurgical or other damage to the reference standard.

9.3 Rotate the reference standard in either 90 or 120° increments to determine the location of the electrical center in the examining coil. Mechanically adjust the position of the tube within the coil to obtain nearly equal responses from the artificial discontinuities regardless of their circumferential orientation.

9.4 The length of tubing not examined due to the end effect may be determined by selecting a tube of low background noise and making a series of holes or notches at appropriate intervals near the end of this special tube. See Fig. 3. Pass the tube through the examination setup at the production speed with the artificial discontinuities end first, and then with the artificial discontinuities end last. Determine the distance from

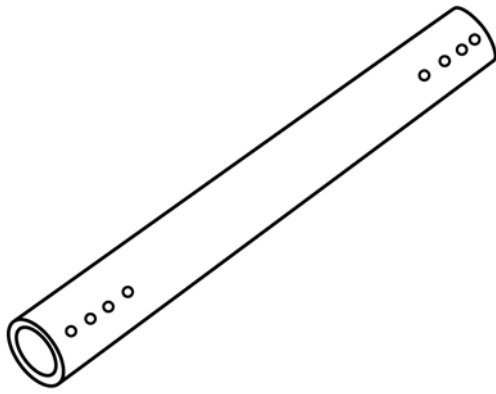

FIG. 3 Location of Artificial Discontinuities (Notches or Drilled Holes) that Can Be Used to Determine Extent of End Effect

the tube end to the point at which the signal response from successive discontinuities is uniform with a recording device such as a pen recorder or memory oscilloscope. A signal suppression method (photo relay, mechanical switches, or proximity devices are commonly used) may be used to permit examination only when the length of tubing exhibiting uniform signals is within the test coil. The section of tube passing through the test coil representing the end effect is not examined.

9.5 As an option to 9.4, the length of tubing representing the end effect may be determined by selecting a tube of low background noise and making a hole or notch at a point 6 to 8 in. (152 to 203 mm) from the tube end. Pass the tube through the test coil at the production test speed with the artificial discontinuity end first and then with the artificial discontinuity end last. If the artificial discontinuity is not detected, make another artificial discontinuity farther from the end. If it is detected, cut off 0.5-in. (12.7-mm) increments from the end of the tube until the artificial discontinuity is no longer detected. The length from the tube end to the artificial discontinuity that can be detected is that length of tubing representing the end effect.

NOTE 5—It is intended that the extent of the end effect region be determined only once for each diameter, wall thickness, speed, and examination frequency and need not be repeated for each run or during the periodic standardization check.

NOTE 6—Any other suitable means of determining the end effect may be used.

10. Procedure

10.1 Electrically center the tubing in the test coil at the start of the test run. The reference standard may be used, or a separate tube may be prepared for this purpose in accordance with 8.1.1 and 8.1.2. Pass the tube through the examination system and mechanically adjust its position in the test coil such that the requirements of 9.3 are satisfied.

10.2 Standardize the examination system at the start and end of each shift. Re-standardize at the intervals specified in the agreement between the purchaser and the supplier; whenever

improper functioning occurs, resulting in a loss of apparatus sensitivity, re-standardize the system in accordance with Section 9 and re-examine all tubes reexamined since the last standardization.

10.3 After standardization, pass the tubes through the examination system, as described in Section 9.

10.3.1 Accept those tubes that produce output signals conforming to the limits in the applicable product specification.

10.3.2 Tubes that produce output signals not conforming to the limits in the applicable specification may, at the option of the manufacturer, be set aside for re-examination. Upon re-examination, accept those tubes whose output signals are either within acceptable limits (10.3.1), or are demonstrated by other means to be irrelevant.

10.4 Tubes may be examined at the finish size before or after the final anneal or heat treatment, unless otherwise agreed upon by the supplier and the purchaser.

11. Supplemental Information

11.1 The response to subsurface discontinuities decreases as the distance from the surface increases. This is because the density of the eddy currents decreases nearly exponentially with distance from the coil.

11.2 In preparing a reference standard for welded tubing, artificial discontinuities should be placed in both the weld metal and the parent metal if both are to be examined. If the welded tube is cold worked and recrystallized, or if the weld exhibits the same electrical properties as the parent metal (that is, those metal properties that affect the response of the eddy-current system), the artificial discontinuities may be placed in either weld metal or parent metal. Then adjust the apparatus to obtain an optimum signal-to-noise ratio.

11.3 When examining only the weld bead, place the discontinuities only in the weld bead.

11.4 When choosing the examining speed, consider the examination frequency and the type of apparatus being used. Certain types of equipment can detect discontinuities at very slow speeds, or statically, while other types require a certain minimum speed. The examining speed may need to be linked to the speed at which the material is being processed at the point of examination.

11.5 *Magnetic Saturation System*—The magnetic saturation system shall consist of a suitable method of applying a strong d-c magnetic field to the region of the tube adjacent to the coil or probe coil assembly so as to render that region of the tube essentially nonmagnetic. Typical systems employ either permanent magnets or controllable electromagnets.

12. Keywords

12.1 discontinuities; eddy-current; electrical resistivity; electromagnetic; encircling coil; magnetic saturation; nickel; nickel alloy; pipe (see Note 1); probe; probe coil; tubes; tubular products; welded tubing

SUMMARY OF CHANGES

Committee E07 has identified the location of selected changes to this standard since the last issue (E571 - 98(07)) that may impact the use of this standard. (August 1, 2012)

(1) Subsection 1.3: The units statement has been revised to conform with the Form and Style guide.

(2) Subsection 4.1.2: Clarified that if a rotating probe is used, the probe rotates around the circumference of the tube and not its own axis. Also added a statement regarding differences in the depth of penetration of the magnetic field associated with probe type.

(3) Throughout the document edits were made to improve the consistency of the use of the terms test and examination.

ASTM International takes no position respecting the validity of any patent rights asserted in connection with any item mentioned in this standard. Users of this standard are expressly advised that determination of the validity of any such patent rights, and the risk of infringement of such rights, are entirely their own responsibility.

This standard is subject to revision at any time by the responsible technical committee and must be reviewed every five years and if not revised, either reapproved or withdrawn. Your comments are invited either for revision of this standard or for additional standards and should be addressed to ASTM International Headquarters. Your comments will receive careful consideration at a meeting of the responsible technical committee, which you may attend. If you feel that your comments have not received a fair hearing you should make your views known to the ASTM Committee on Standards, at the address shown below.

This standard is copyrighted by ASTM International, 100 Barr Harbor Drive, PO Box C700, West Conshohocken, PA 19428-2959, United States. Individual reprints (single or multiple copies) of this standard may be obtained by contacting ASTM at the above address or at 610-832-9585 (phone), 610-832-9555 (fax), or service@astm.org (e-mail); or through the ASTM website (www.astm.org). Permission rights to photocopy the standard may also be secured from the Copyright Clearance Center, 222 Rosewood Drive, Danvers, MA 01923, Tel: (978) 646-2600; <http://www.copyright.com/>