



# Standard Practice for Installing Sound-Isolating Lightweight Partitions<sup>1</sup>

This standard is issued under the fixed designation E 497; the number immediately following the designation indicates the year of original adoption or, in the case of revision, the year of last revision. A number in parentheses indicates the year of last approval. A superscript epsilon ( $\epsilon$ ) indicates an editorial change since the last revision or reapproval.

## 1. Scope

1.1 This practice covers measures intended to prevent situations or conditions that will detract from the sound-insulating properties of acoustically-rated lightweight partitions. It is not intended to include all sound insulating constructions. Many acoustically-rated partitions are also fire rated and when being installed must be built in accordance with the construction details specified in the fire test construction. In any event, applicable building codes and regulations should be checked for possible conflicts.

1.2 Excluded from this scope are masonry type partitions having all or part of their construction from brick, concrete block, aggregate block, plaster block, poured concrete, etc. Also excluded are operable and demountable partitions (Operable are those partitions with a mechanism for easy movement; demountable partitions are those which are designed and installed with the intent of later being taken down and re-erected by a crew over a period of time, with the components being reusable). Not excluded are those partitions which are lightweight but have thin brick, tile, or plaster on one or both faces.

1.3 Plumbing wall and kitchen problems are excluded from this document.

1.4 The values stated in inch-pound units are to be regarded as the standard. The values given in parentheses are for information only.

1.5 *This standard may involve hazardous materials, operations, and equipment. This standard does not purport to address all of the safety concerns associated with its use. It is the responsibility of the user of this standard to establish appropriate safety and health practices and determine the applicability of regulatory limitations prior to use.*

## 2. Referenced Documents

### 2.1 ASTM Standards:

C 634 Terminology Relating to Environmental Acoustics<sup>2</sup>

<sup>1</sup> This practice is under the jurisdiction of ASTM Committee E-33 on Environmental Acoustics, and is the direct responsibility of Subcommittee E 33.04 on Application of Acoustical Materials and Systems.

Current edition approved August 10, 1999. Published September 1999. Originally published as E 497 – 73 T. Last previous edition E 497 – 89 (1994)<sup>\*1</sup>.

<sup>2</sup> *Annual Book of ASTM Standards*, Vol 04.06.

C 919 Practice for Use of Sealants in Acoustical Applications<sup>3</sup>

E 90 Test Method for Laboratory Measurement of Airborne-Sound Transmission Loss of Building Partitions<sup>2</sup>

E 336 Test Method for Measurement of Airborne Sound Insulation in Buildings<sup>2</sup>

E 413 Classification for Rating Sound Insulation<sup>2</sup>

E 597 Practice for Determining Single-Number Rating of Airborne Sound Isolation for Use in Multi-Unit Building Specifications<sup>2</sup>

## 3. Terminology

### 3.1 Definitions of Terms Specific to This Standard:

3.1.1 *caulking*—a non-hardening permanently resilient material used to seal sound leaks and to damp vibration.

3.1.2 *sound leaks*—openings, often extremely small holes or cracks, through which sound can pass. In general, an air leak is a sound leak.

3.1.3 *short-circuit*—to reduce the transmission loss of a partition by direct connections that have low resistance to sound.

3.2 Definitions—for additional definitions of terms used in this standard, see Terminology C 634.

## 4. Summary of Practice

4.1 This practice details precautions that should be taken during the installation of lightweight partitions to maximize their sound insulating effectiveness. Potential problems with flanking sound transmission and sound leaks are discussed and methods to avoid these are offered. A number of figures and drawings are included to illustrate the potential errors and suggested precautions.

## 5. Significance and Use

5.1 Many of the benefits of walls with high sound transmission class ratings (STC), can be lost because of poor construction details or improper installation. Established reputable manufacturers of building materials and systems exercise great care to properly determine the acoustical performance of their products and, specifically, the ability of wall systems to attenuate sound. The laboratory-measured performance of

<sup>3</sup> *Annual Book of ASTM Standards*, Vol 04.07.

partitions will not be achieved in buildings unless both the construction details of the acoustically rated wall and the installation details such as described in this procedure are strictly followed. This practice is intended to emphasize several factors that can substantially reduce the sound insulation of an otherwise good wall and to illustrate satisfactory solutions.

5.2 The STC rating of the partition alone does not necessarily determine the acoustic privacy of the total construction.

NOTE 1—Adherence to the precautions described in this recommended practice for control of sound leaks and flanking transmission should help achieve the noise reduction anticipated by laboratory tests. However, it is cautioned that the control of workmanship, materials, and site conditions is not as simple as it is in a laboratory.

## 6. Flanking Sound

6.1 Noise can flank a good sound-attenuating wall if there are other paths with less resistance. Attics, crawl spaces, plenums, and joist spaces are examples (see Fig. 1). Also, noise can travel from room to room through such structural members as studs, joists, and subfloors.

6.2 When continuous double gypsum board is used through the floor-ceiling system, it is effective as a fire barrier, but it is often detrimental to noise reduction. The continuity can result in vertical flanking paths. Such a construction is shown in Fig. 2 along with two remedial alternatives. Flanking over or under a partition can be reduced with a barrier in the attic (Fig. 3) or in a crawl space (Fig. 4). Additional guidance may be found in Practice C 919.

6.3 Flanking paths between joists, when they are perpendicular to the partition, can be blocked by solid blocking (Fig. 5) or high-density barrier (Fig. 6 and Fig. 7).

6.4 Flanking paths between joists that are parallel to the partition can be blocked by the method shown in Fig. 8.

6.5 In bathrooms, a sound barrier should be in place between tubs sharing a common wall (Fig. 9) with an airtight seal.

6.6 Finish the areas behind soffits above cabinets to eliminate acoustical flanking transmission (Fig. 10).

## 7. Leaks

7.1 A sound-insulating wall, to be effective, must be virtually airtight. The importance of this cannot be overemphasized. There must be no significant sound path around, through, or over the barrier. Extremely small leaks can seriously reduce the sound insulation of a wall. The more efficient the barrier, the more small leaks degrade the acoustical performance.

7.2 A positive method of sealing leaks around the perimeter of party walls is with caulking. Two beads, minimum, at a partition are recommended. Care should be taken that an effective seal is obtained (Fig. 11).

7.3 Where multiple layers of panels are used, stagger the joints at the corners as shown in Fig. 12 and seal the face layer with joint compound and tape.

7.4 When a partition intersects another partition somewhere other than a corner, care in construction detail is necessary to avoid structural flanking by the intersected partition (Fig. 12a).

7.5 Penetrations to cavity walls in the form of electrical boxes (for duplex outlets, light switches, cable, telephone, and

so on) can significantly degrade the sound insulation of the wall. The effect of such penetrations can be minimized by performing one or more of the following.

### 7.5.1 Minimum Separation:

Common metal or plastic boxes that do not form an airtight seal to the wall surface and the electrical cable must be offset. A 600 mm (24 in.) offset between boxes should be considered a bare minimum especially if the cavity does not contain insulation. Cavity insulation will greatly reduce the effect of closely spaced boxes and should be installed as shown in Fig. 13 so that the back of the boxes are covered and the direct line-of-sight is blocked.

### 7.5.2 Airtight Boxes:

If an adequate offset can not be achieved then vapor barrier boxes intended for exterior walls (that is, those that provide an airtight seal between the box and the wall face as well as to the cables) can be used. Alternately, common metal or plastic boxes can be made sufficiently airtight through the use of vapor barrier inserts and liberal caulking between the box and the wall opening as well as all penetrations to the box. This is less desirable than using the inherently airtight vapor barrier boxes.

### 7.5.3 Baffles:

In a double stud wall where the minimum offset can not be achieved and airtight boxes can not be used then a gypsum board baffle may be used as shown in Fig. 14. The baffle should extend at least 600 mm (24 in.) above and below the boxes and the wall cavity must contain insulation.

7.6 Recessed cabinets can cause sound leaks that are serious. They should be carefully caulked at the opening as shown in Fig. 15 and staggered at least 24 in. (610 mm). If the minimum spacing is not possible, the backs of the stud spaces should be covered with the same type of board as that used on the face, as shown in Fig. 16.

## 8. Fastenings

8.1 Do not use more screws, nails, or staples than recommended by the manufacturer. Additional fasteners may reduce the sound insulation of the partition.

8.2 It is important to use fasteners of the correct size, particularly in resilient attachment. Short circuits can be caused by fasteners that are too long (Fig. 17).

## 9. Miscellaneous

9.1 Glass or mineral fiber in the form of batts or blankets should be carefully fitted within the partition cavity, behind the outlets, and around blocking, fixtures, and cutouts.

9.2 Sound-deadening board, or other porous building board, is most effective, when placed directly under the gypsum board or other nonporous surface material. Be careful to use no more nails than recommended.

9.3 If multiple layers of panels are used, stagger the joints in adjacent layers as far apart as possible (Fig. 18).

9.4 If the surface layers on each side of the partition are of equal weight and are fastened symmetrically, they will have the same resonance frequencies. To reduce sound transmission by preventing the surface layers from vibrating sympathetically, they should be constructed with unequal thicknesses of material or dissimilar attachments on opposite faces (Fig. 19).

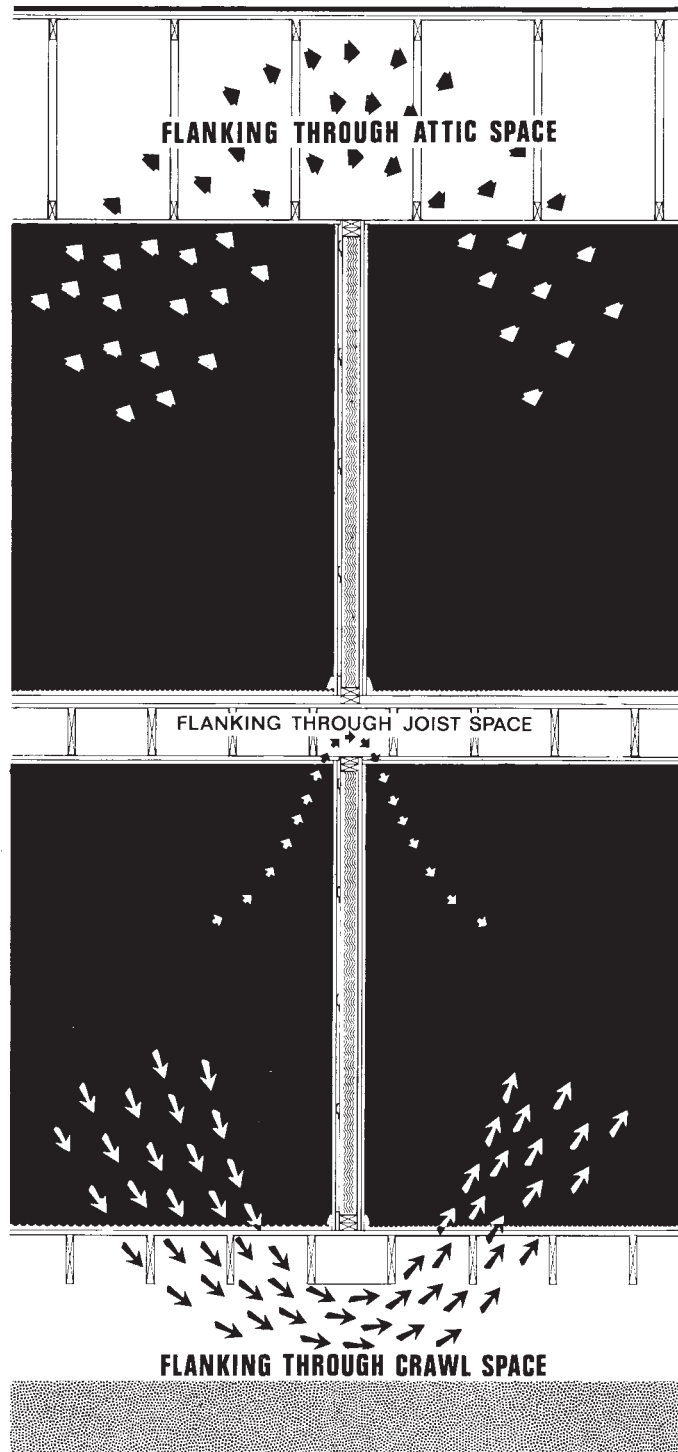

FIG. 1 Flanking Paths to be Avoided

9.5 If blocking that supports plumbing or conduits is nailed to the studs in each wall face, it will “couple” the two wall faces, which tends to nullify the benefit of vibration isolation. Use blocking that is attached to only one stud system (Fig. 20).

9.6 Floor penetration cut or provided for wiring, ductwork, or pipe lines, which pass from one room to another should be filled with caulk or a similar dense agent to reduce possible flanking.

**10. Keywords**

10.1 acoustical; lightweight partitions; partitions; sound-isolating

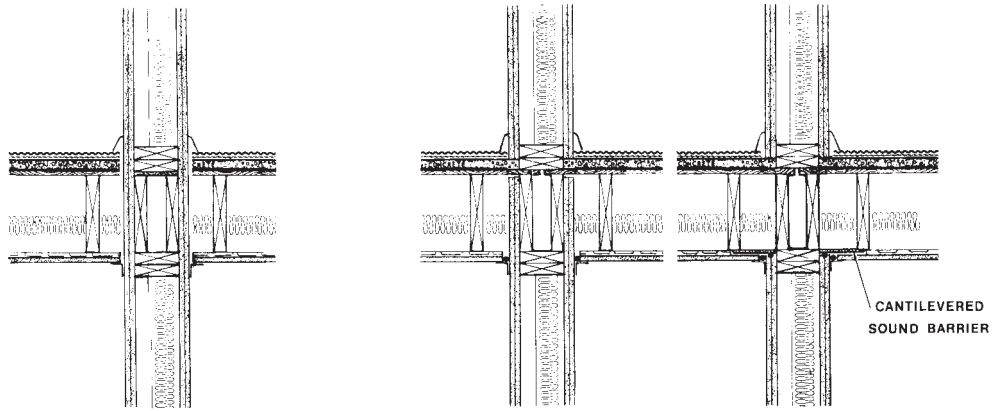

PERMITS VERTICAL FLANKING OF FLOOR-CEILING ASSEMBLY  
RECOMMENDED ALTERNATIVES  
FIG. 2 Continuous Gypsum Board Through the Floor-Ceiling Assembly Must be Avoided to Prevent Vertical Flanking

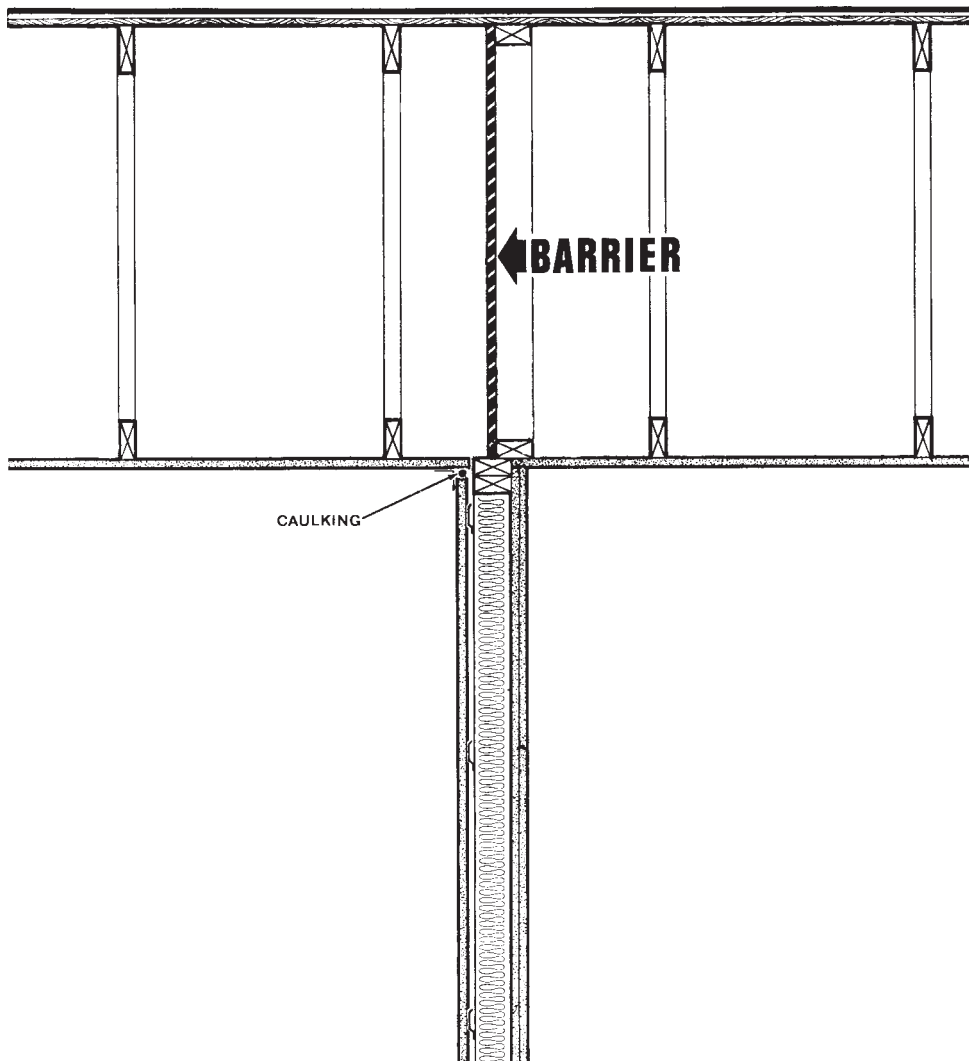

FIG. 3 An Installed Barrier in an Attic Space Above a Party Wall

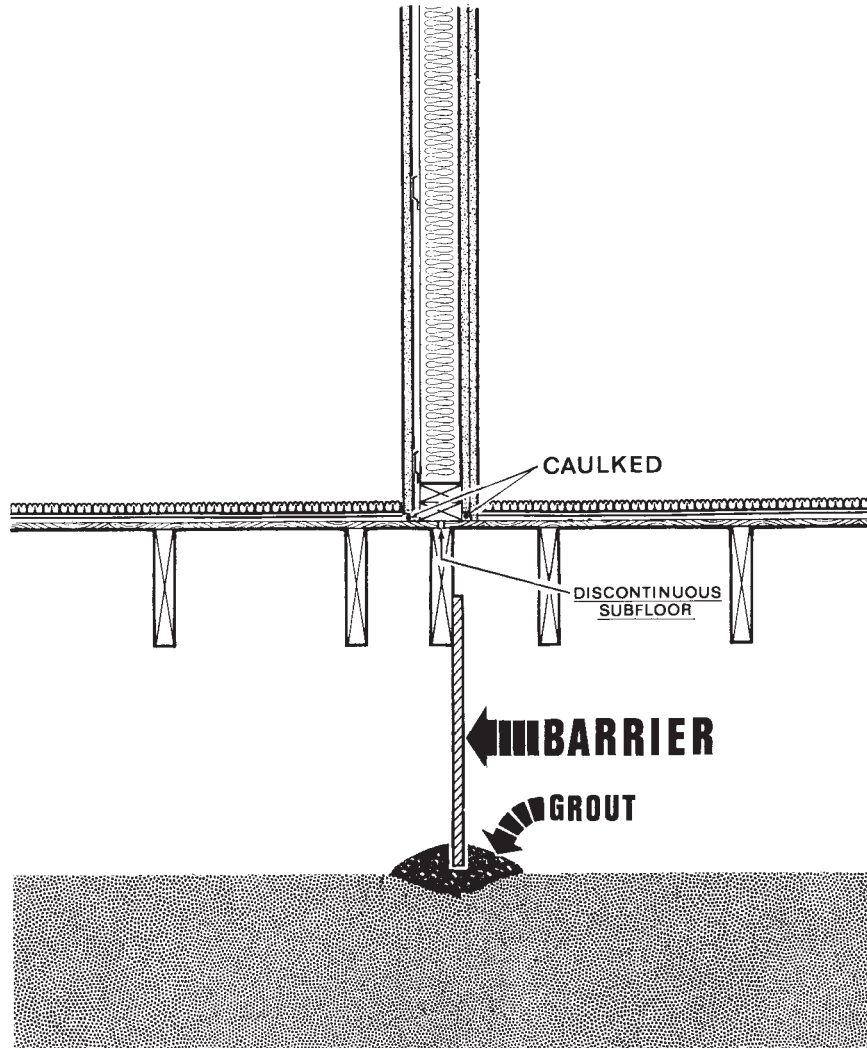

FIG. 4 An Installed Barrier in a Crawl Space Below a Party Wall

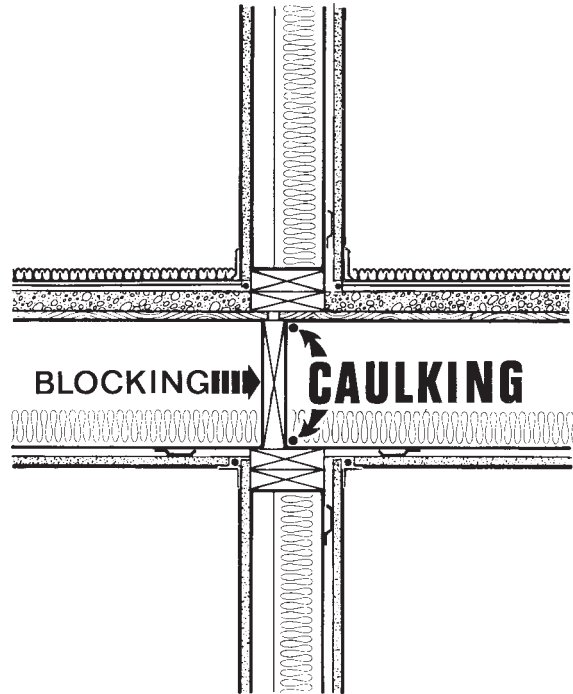
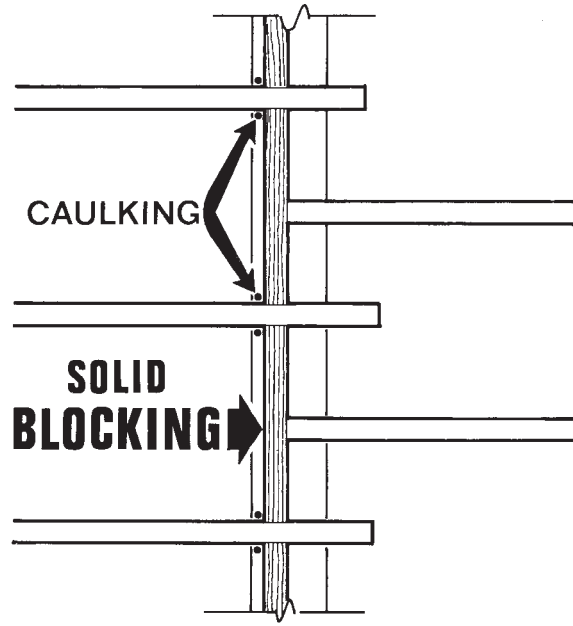

FIG. 5 Blocking and Caulking Between Joists at a Party Wall

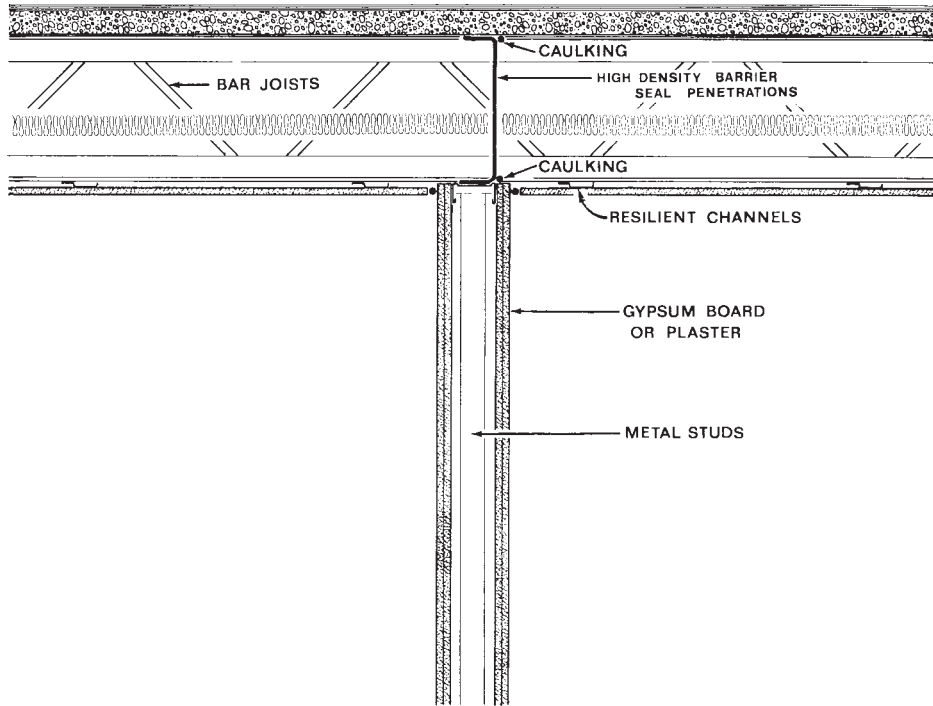

FIG. 6 A Barrier Recommended for Open Joist Ceiling Plenum

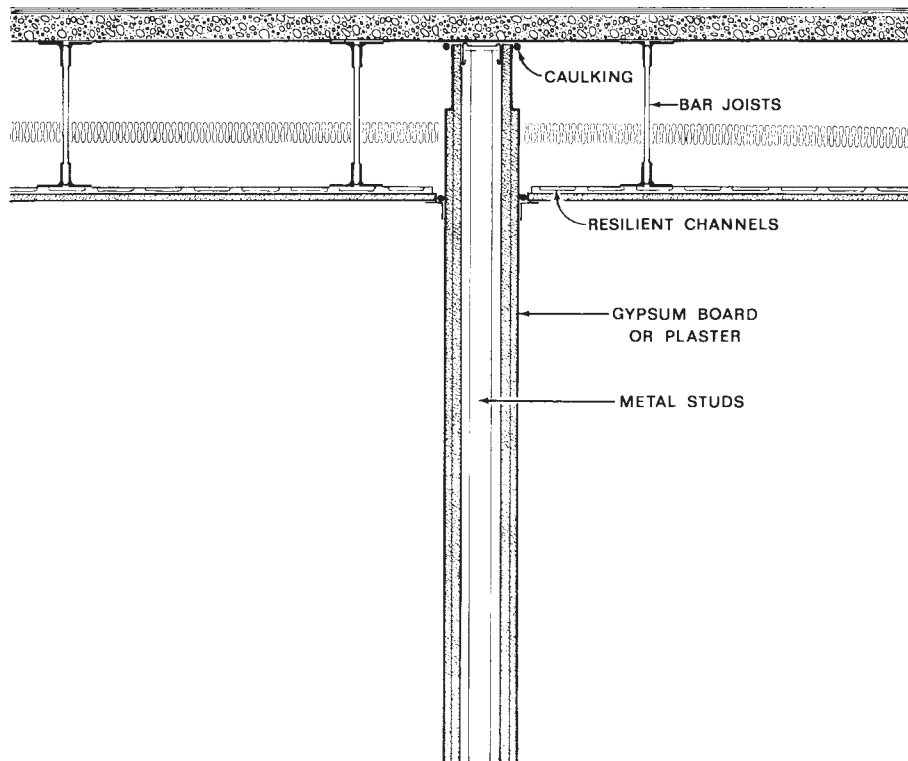

FIG. 7 A Partition Extended into an Open Ceiling to Prevent Flanking

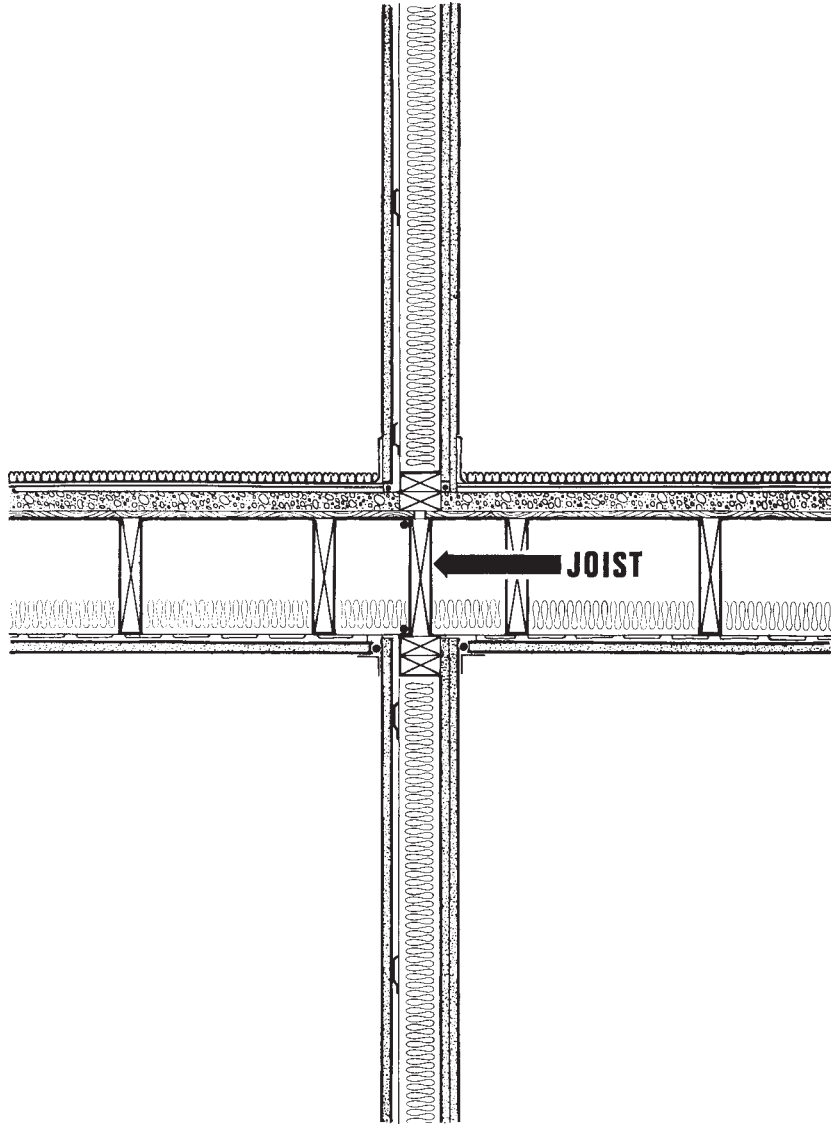

FIG. 8 A Single Parallel Joist Serves as a Flanking Barrier



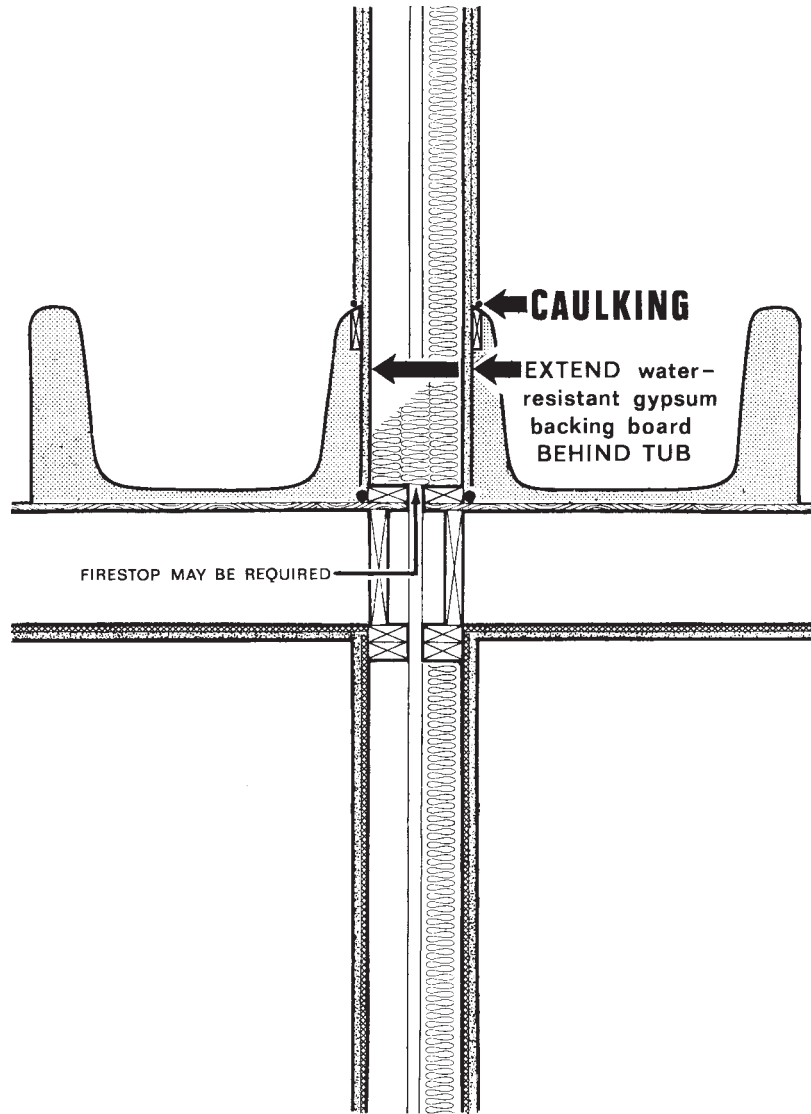

FIG. 9 Recommended Gypsum Board Application Behind Bathtubs

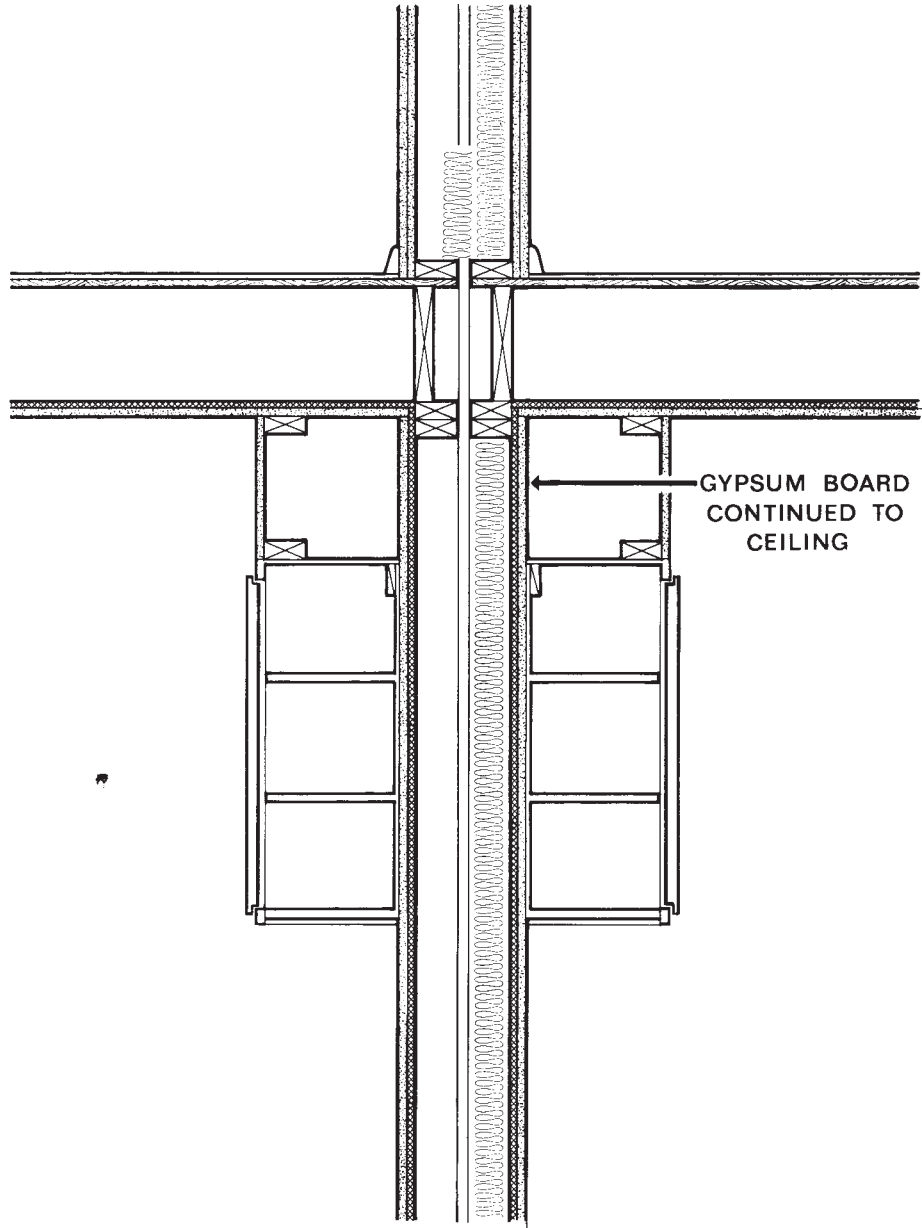

FIG. 10 Recommended Gypsum Board Application in Soffit Areas

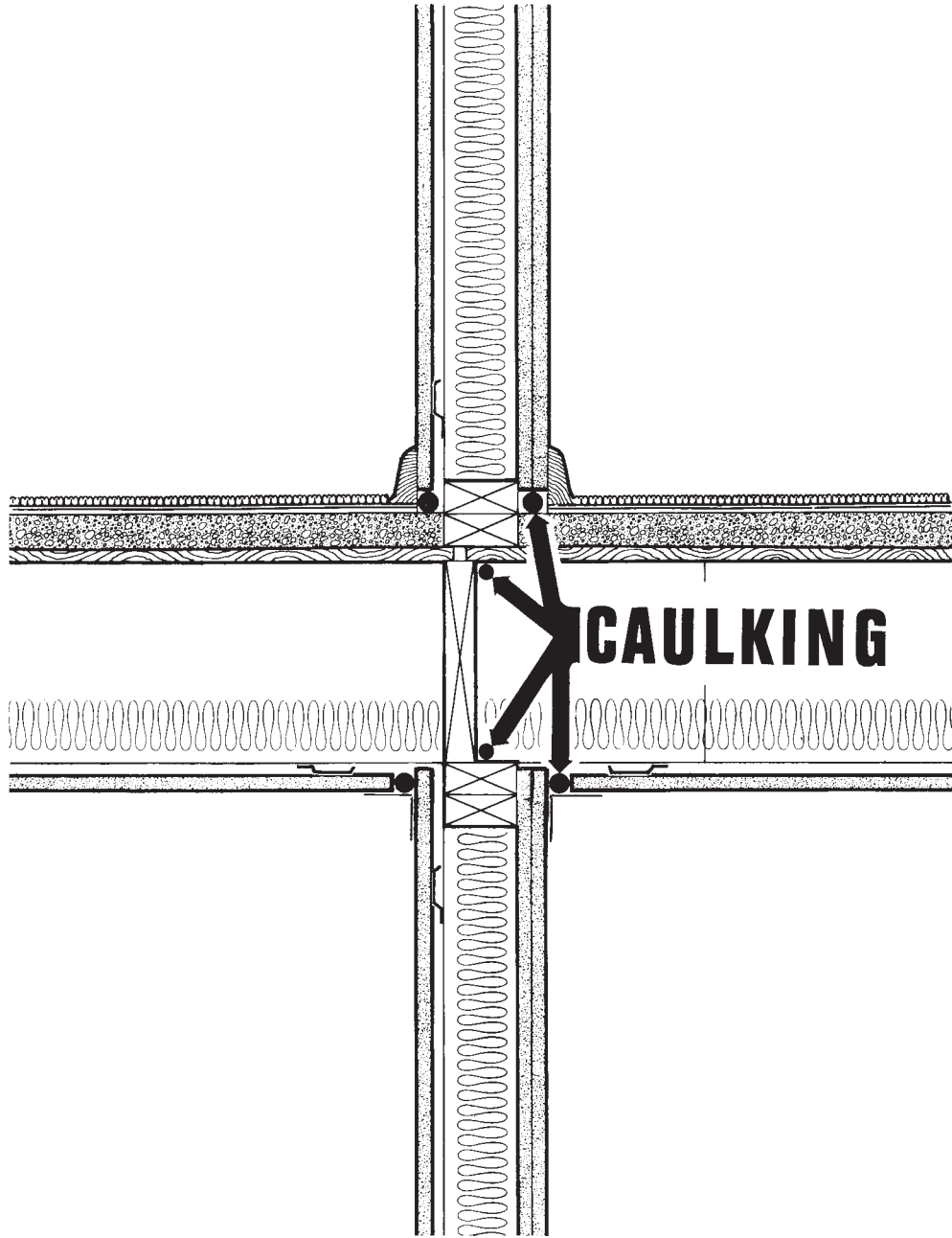
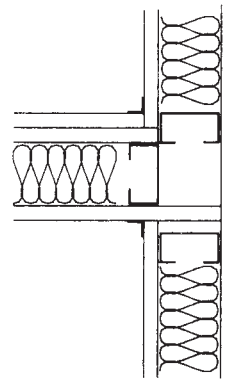
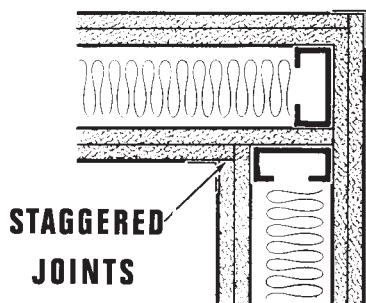
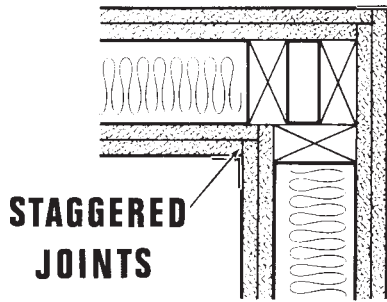

FIG. 11 Caulking to Prevent Possible Sound Leaks



(b) Intersecting Partitions

FIG. 12 (a) Recommended Gypsum Board Staggering at Corners

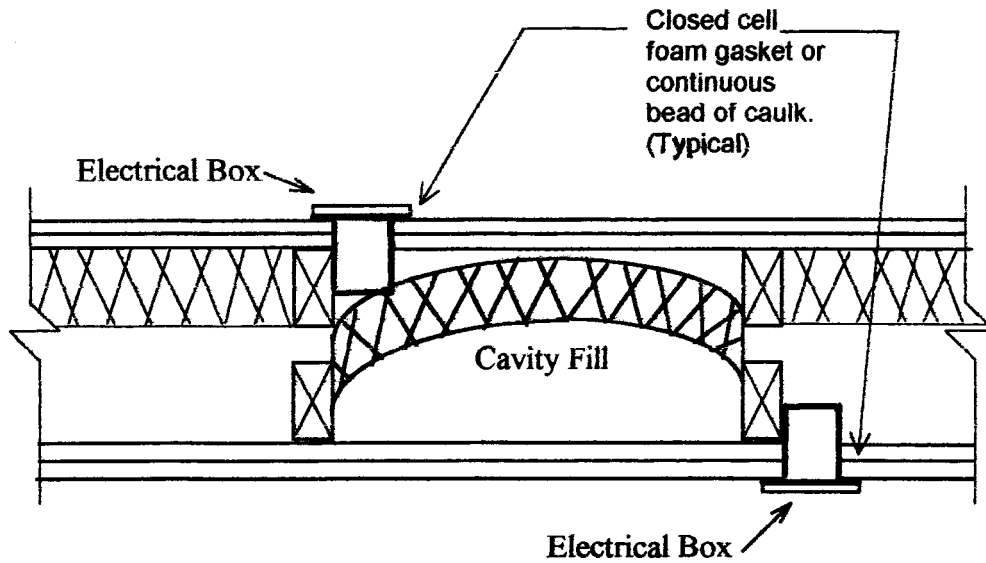

FIG. 13 Offset Electrical Boxes (600 mm or 24 in.) Showing the Preferred Method of Installing the Cavity Insulation so that the Backs of the Boxes are Covered

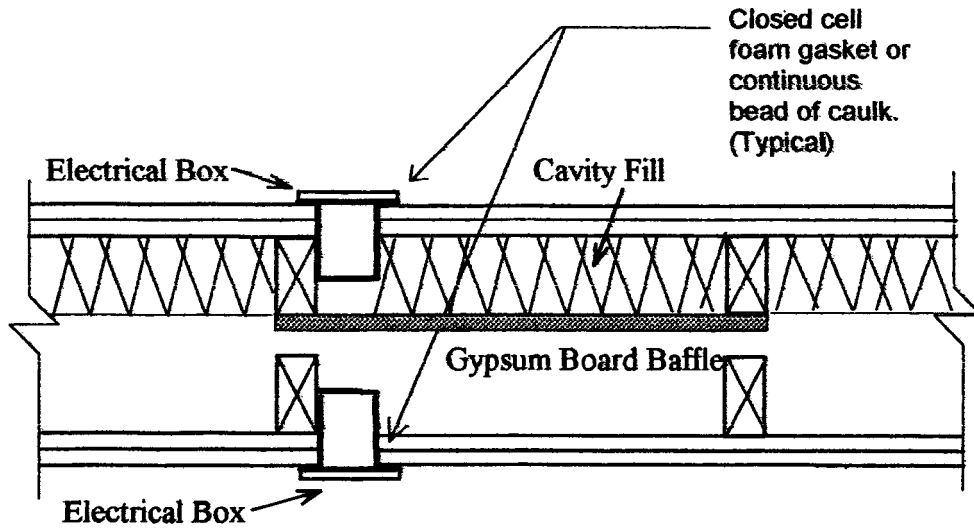

FIG. 14 Gypsum Board Baffles can be Used Where the Minimum Offset and Airtight Boxes can not be Utilized. The Baffle Should Extend at Least 24 in. (600 mm) Above and Below the Boxes and the Wall Cavity must Contain Insulation

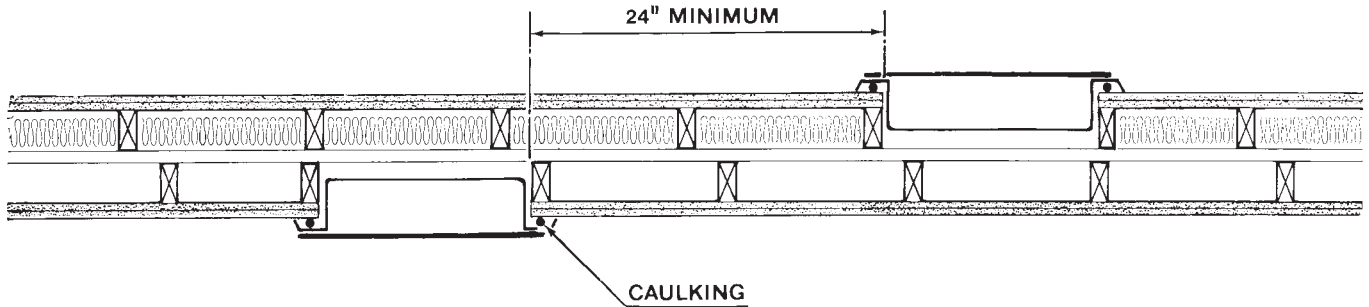

FIG. 15 Properly Spaced Cabinets Reduce Sound Transmission

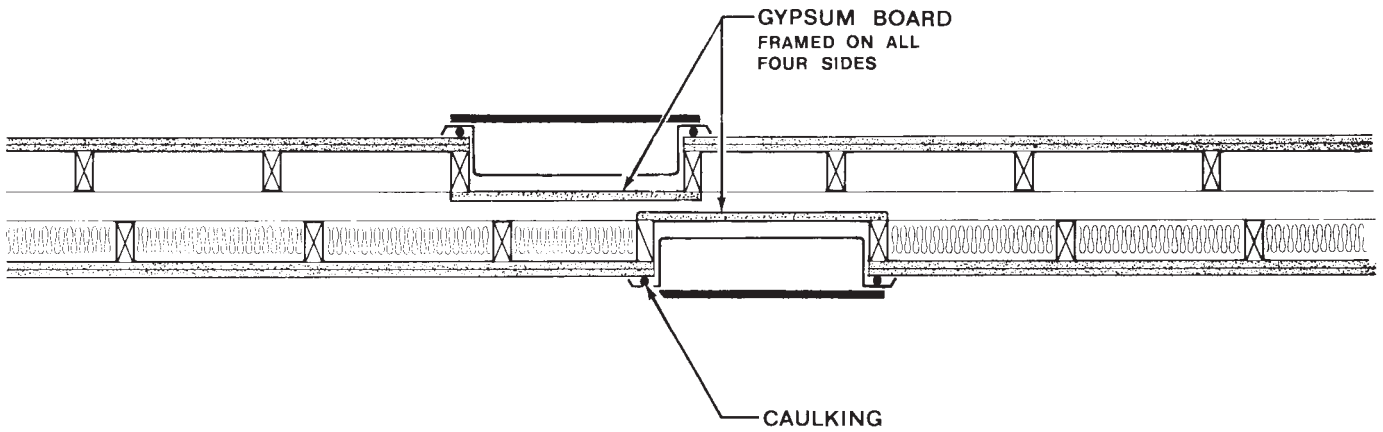

FIG. 16 Nearly Back-to-Back Cabinets Need Caulking and Backing with Gypsumboard

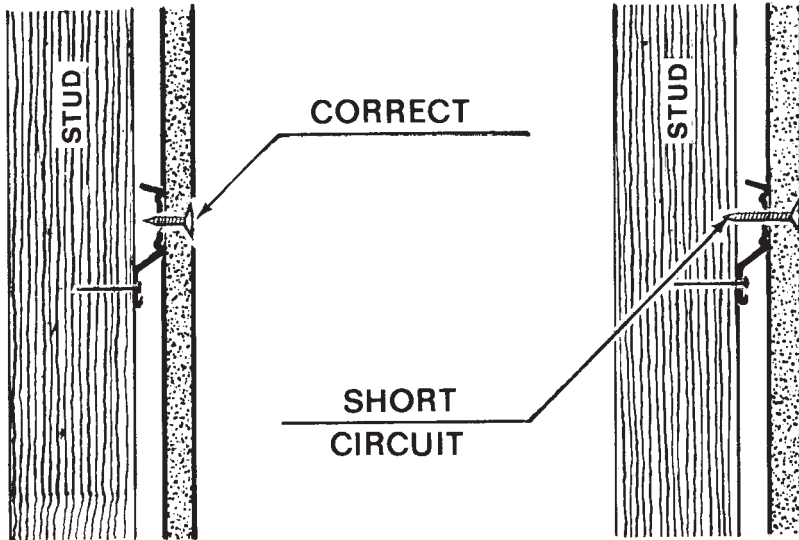

FIG. 17 Vibration Isolation Obtained with Resilient Channels is Lost if Screws are Too Long

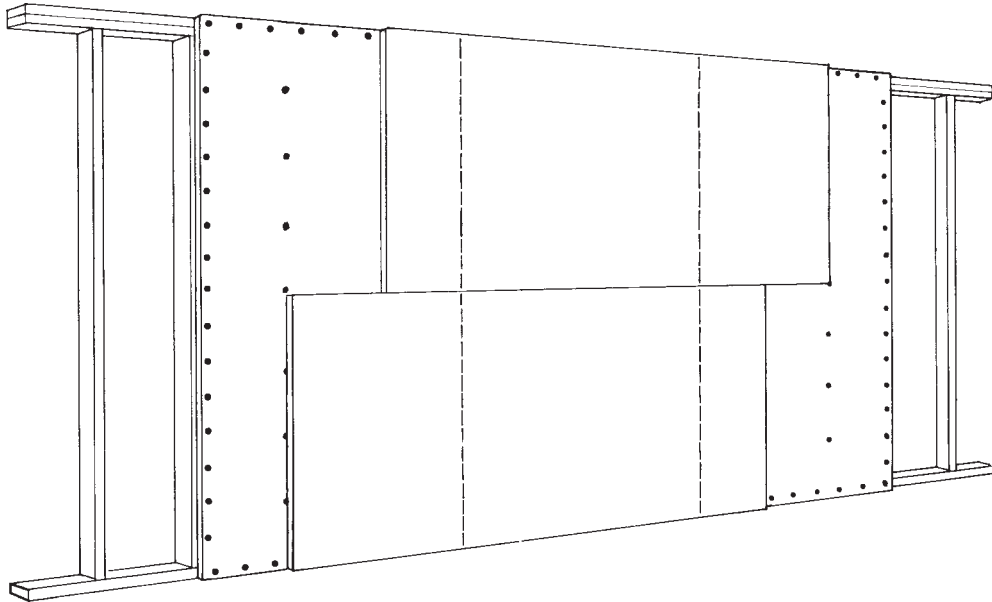

FIG. 18 A Recommended Arrangement of Multiple Layer of Gypsum Board

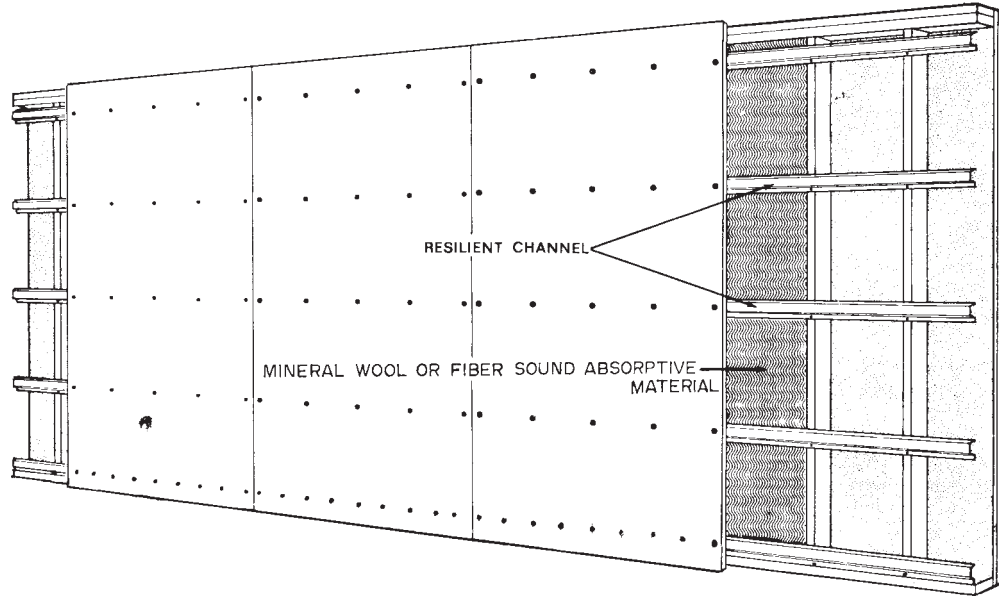
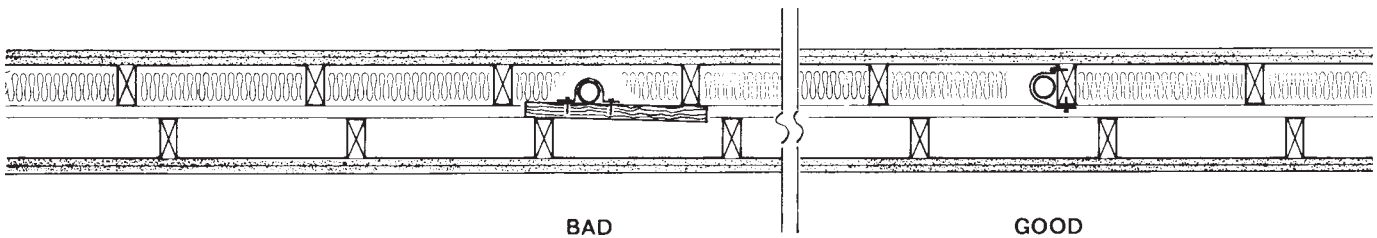

FIG. 19 An Example of Unequal Thicknesses of Surface Layers and Dissimilar Attachments



NOTE 1—Can cause a short circuit. When plumbing must be blocked, it is good practice to attach directly to the stud.  
**FIG. 20 Coupling of Double Walls**

ASTM International takes no position respecting the validity of any patent rights asserted in connection with any item mentioned in this standard. Users of this standard are expressly advised that determination of the validity of any such patent rights, and the risk of infringement of such rights, are entirely their own responsibility.

This standard is subject to revision at any time by the responsible technical committee and must be reviewed every five years and if not revised, either reapproved or withdrawn. Your comments are invited either for revision of this standard or for additional standards and should be addressed to ASTM International Headquarters. Your comments will receive careful consideration at a meeting of the responsible technical committee, which you may attend. If you feel that your comments have not received a fair hearing you should make your views known to the ASTM Committee on Standards, at the address shown below.

This standard is copyrighted by ASTM International, 100 Barr Harbor Drive, PO Box C700, West Conshohocken, PA 19428-2959, United States. Individual reprints (single or multiple copies) of this standard may be obtained by contacting ASTM at the above address or at 610-832-9585 (phone), 610-832-9555 (fax), or service@astm.org (e-mail); or through the ASTM website (www.astm.org).