



Standard Test Methods for Stress Relaxation for Materials and Structures¹

This standard is issued under the fixed designation E328; the number immediately following the designation indicates the year of original adoption or, in the case of revision, the year of last revision. A number in parentheses indicates the year of last reapproval. A superscript epsilon (ϵ) indicates an editorial change since the last revision or reapproval.

INTRODUCTION

These test methods cover a broad range of testing activities. To aid in locating the subject matter pertinent to a particular test, the standard is divided into a general section, which applies to all stress relaxation tests for materials and structures. This general section is followed by letter-designated parts that apply to tests for material characteristics when subjected to specific, simple stresses, such as uniform tension, uniform compression, bending or torsion. To choose from among these types of stress, three factors should be considered:

(1) When the material data are to be applied to the design of a particular class of component, the stress during the relaxation test should be similar to that imposed on the component. For example, tension tests are suitable for bolting applications and bending tests for leaf springs.

(2) Tension and compression relaxation tests have the advantage that the stress can be reported simply and unequivocally. During bending relaxation tests, the state of stress is complex, but can be accurately determined when the initial strains are elastic. If plastic strains occur on application of force, stresses can usually be determined within a bounded range only. Tension relaxation tests, when compared to compression tests, have the advantage that it is unnecessary to guard against buckling. Therefore, when the test method is not restricted by the type of stress in the component, tension testing is recommended.

(3) Bending tests for relaxation, when compared to tension and compression tests, have the advantage of using lighter and simpler apparatus for specimens of the same cross-sectional area. Strains are usually calculated from deflection or curvature measurements. Since the specimens can usually be designed so that these quantities are much greater than the axial deformation in a direct stress test, strain is more easily measured and more readily used for machine control in the bending tests. Due to the small forces normally required and the simplicity of the apparatus when static fixtures are sufficient, many specimens can be placed in a single oven or furnace when tests are made at elevated temperatures.

1. Scope*

NOTE 1—The method of testing for the stress relaxation of plastics has been withdrawn from this standard, and the responsibility has been transferred to Practice [D2991](#).

¹ These test methods are under the jurisdiction of ASTM Committee [E28](#) on Mechanical Testing and is the direct responsibility of Subcommittee [E28.04](#) on Uniaxial Testing.

Current edition approved Nov. 1, 2013. Published May 2014. Originally approved in 1967. Last previous approved in 2008 as E328–02(2008). DOI: 10.1520/E0328-13.

1.1 These test methods cover the determination of the time dependence of stress (stress relaxation) in materials and structures under conditions of approximately constant constraint, constant environment, and negligible vibration.

*A Summary of Changes section appears at the end of this standard

In the procedures recommended, the material or structure is initially constrained by externally applied forces, and the change in the external force necessary to maintain this constraint is determined as a function of time.

1.2 Specific methods for conducting stress relaxation tests on materials subjected to tension, compression, bending and torsion stresses are described in Parts A, B, C, and D, respectively. These test methods also include recommendations for the necessary testing equipment and for the analysis of the test data.

1.3 It is recognized that the long time periods required for these types of tests are often unsuited for routine testing or for specification in the purchase of material. However, these tests are valuable tools in obtaining practical design information on the stress relaxation of materials subjected to the conditions enumerated, and in investigations of the fundamental behavior of materials.

1.4 *Units*—The values stated in inch-pound units are to be regarded as standard. The values given in parentheses are mathematical conversions to SI units that are provided for information only and are not considered standard.

1.5 *This standard does not purport to address all of the safety concerns, if any, associated with its use. It is the responsibility of the user of this standard to establish appropriate safety and health practices and determine the applicability of regulatory limitations prior to use.*

2. Referenced Documents

2.1 ASTM Standards:²

D2991 Test Method for Stress-Relaxation of Plastics (Withdrawn 1990)³

E4 Practices for Force Verification of Testing Machines

E6 Terminology Relating to Methods of Mechanical Testing

² For referenced ASTM standards, visit the ASTM website, www.astm.org, or contact ASTM Customer Service at service@astm.org. For *Annual Book of ASTM Standards* volume information, refer to the standard's Document Summary page on the ASTM website.

³ The last approved version of this historical standard is referenced on www.astm.org.

E8/E8M Test Methods for Tension Testing of Metallic Materials

E9 Test Methods of Compression Testing of Metallic Materials at Room Temperature

E83 Practice for Verification and Classification of Extensometer Systems

E139 Test Methods for Conducting Creep, Creep-Rupture, and Stress-Rupture Tests of Metallic Materials

E1012 Practice for Verification of Testing Frame and Specimen Alignment Under Tensile and Compressive Axial Force Application

3. Terminology

3.1 *Definitions*: Terms common to mechanical testing.

3.1.1 *stress relaxation, n*—the time-dependent decrease in stress in a solid under given constraint conditions.

3.1.2 *initial stress, σ_0 , [FL⁻²], n*—the stress introduced into a specimen by imposing the given constraint conditions before stress relaxation begins.

3.1.2.1 *Discussion*—This is sometimes called instantaneous stress.

3.1.3 *zero time, t_0 , n*—the time when the given stress or constraint conditions are initially obtained in a stress relaxation test.

3.1.4 *relaxation rate [FL⁻² T⁻¹], n*—the absolute value of the slope of the relaxation curve at a given time.

3.1.4.1 *Discussion*—A relaxation curve is a plot of either the remaining time or relaxed stress as a function of time.

3.1.5 *relaxed stress [FL⁻²], n*—the initial stress minus the remaining stress at a given time during a stress-relaxation test.

3.1.6 *remaining stress [FL⁻²], n*—the stress remaining at a given time during a stress-relaxation test.

3.2 *Definitions of Terms Specific to This Standard:*

3.2.1 *spherometer*—an instrument used to measure circular or spherical curvature.

3.2.2 *indicated nominal temperature or indicated temperature*—the temperature that is indicated by the temperature-measuring device.

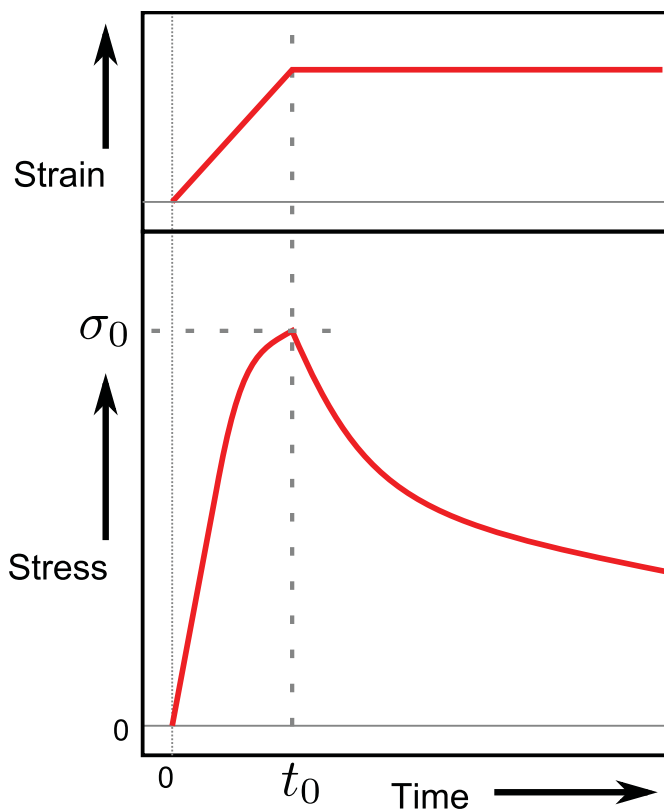

FIG. 1 Characteristic Behavior During Force Application Period in a Relaxation Test (a)

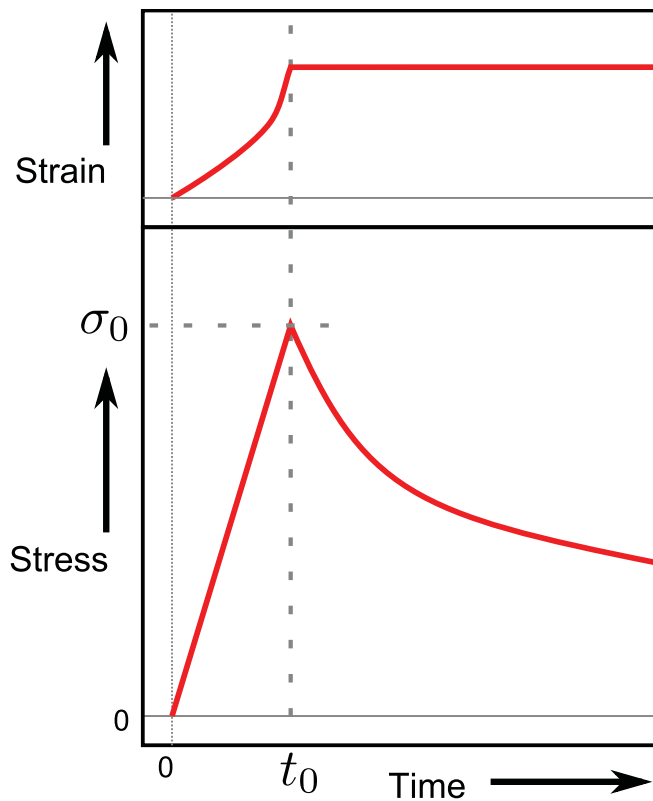

FIG. 1 Characteristic Behavior During Force Application Period in a Relaxation Test (b) (continued)

4. Summary of Test Methods

4.1 In each of the various methods of stress application described in the applicable specific sections, the specimen is subjected to an increasing force until the specified initial strain is attained (see *zero time* in 3.1.3 and in Fig. 1). For the duration of the test, the specimen constraint is maintained constant. The initial stress is calculated from the initial force (moment, torque) as measured at zero time, the specimen geometry, and the appropriate elastic constants, often using simple elastic theory. The remaining stress may be calculated from the force (moment or torque) determined under constraint conditions either continuously (4.1.1), periodically (4.1.2), or by elastic springback at the end of the test period 4.1.3.

4.1.1 Readings are taken continuously from a force indicator while the apparatus adjusts the force to maintain constraint within specified bounds.

NOTE 2—Most force, moment, or torque measuring devices depend on the devices' elasticity to measure the quantities involved. Therefore, it is necessary that when using such devices, to maintain the total strain constant within an upper and lower bound as shown in Fig. 2.

4.1.2 The force required to lift the specimen just free of one or more constraints during the test period is measured.

4.1.3 The elastic springback is measured after removing the test stress at the end of the test period.

4.2 With 4.1.1 and 4.1.2, a single specimen can be used to obtain data for a curve of stress versus time. With 4.1.3, the same specimens may be used to determine the remaining or relaxed stress after various time intervals, if it can be demon-

strated for a given material that identical results are obtained in either using untested or reloaded specimens. Otherwise, individual specimens must be used for each point on the curve.

5. Significance and Use

5.1 Relaxation test data are necessary when designing most mechanically fastened joints to assure the permanent tightness of bolted or riveted assemblies, press or shrink-fit components, rolled-in tubes, etc. Other applications include predicting the decrease in the tightness of gaskets, in the hoop stress of solderless wrapped connections, in the constraining force of springs, and the stability of wire tendons in prestressed concrete.

5.2 The ability of a material to relax at high-stress concentrations such as are present at notches, inclusions, cracks, holes, fillets, etc., may be predicted from stress relaxation data. Such test data are also useful to judge the heat-treatment condition necessary for the thermal relief of residual internal stresses in forgings, castings, weldments, machined or cold-worked surfaces, etc. The tests outlined in these methods are limited to conditions of approximately constant constraint and environment.

5.3 The general stress relaxation test is performed by isothermally applying a force to a specimen with fixed value of constraint. The constraint is maintained constant, and the constraining force is determined as a function of time. The major problem in the stress relaxation test is that constant constraint can be very difficult to maintain. The effects on test results are very significant, and considerable attention must be

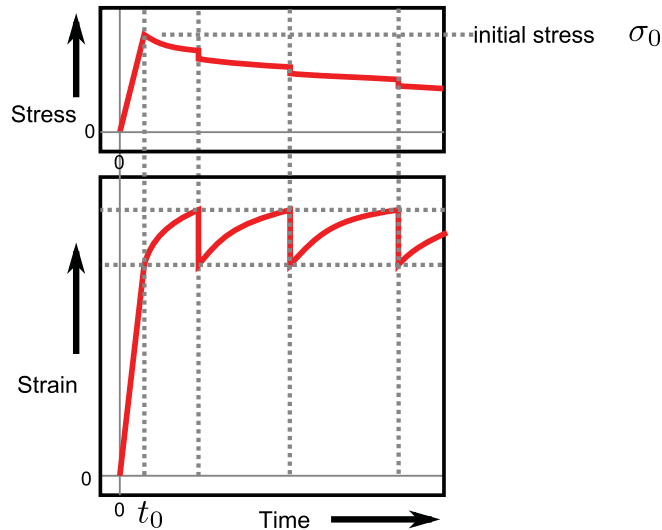

FIG. 2 Derivation of Stress-Relaxation Curve from Continuous Relaxation Technique

given to minimize the constraint variation. Also, experimenters should determine and report the extent of variation in each stress relaxation test so that this factor can be taken into consideration.

5.4 There are many methods of performing the stress relaxation test, each with a different starting procedure. However, the constraint is usually obtained initially by the application of an external force at either a specific force application rate or a specific strain rate. The two methods will produce the characteristic behavior shown in Fig. 1 when the initial stress, σ_0 , exceeds the proportional limit. Some testing machines, while reaching the constraint value, do not produce either a constant force application rate or constant strain rate, but something in between. However, the general characteristics of the data will be similar to those indicated. The stress-application rate in either case should be reasonably rapid, but without impact or vibration, so that any relaxation during the stress application period will be small.

5.5 The stress relaxation test is considered to have started at zero time, t_0 in Fig. 1. This is the reference time from which the observed reduction in force to maintain constant constraint is based. Selection of this time does not imply that the force application procedure or period, or both, are not significant test parameters. These must always be considered in the application of the data.

6. Apparatus

6.1 See the appropriate paragraph under each section.

6.2 The equipment should be located in a draft-free, constant-temperature environment, $\pm 5^\circ\text{F}$ (3°C).

7. Temperature Control and Measurement

7.1 The test space (controlled-temperature room, furnace, or cold box) should be capable of being maintained at a constant temperature by a suitable automatic device. This is the most important single factor in a stress relaxation test since the stress relaxation rate, dimensions, and constraint conditions of the

specimen are dependent upon the test temperature. Any type of heating or cooling that permits close temperature control of the test space environment is satisfactory.

7.2 The temperature should be recorded, preferably continuously or at least periodically. Temperature variations of the specimens from the indicated nominal test temperature due to all causes, including cycling of the controller or position along the specimen gauge length, should not exceed $\pm 5^\circ\text{F}$ (3°C) or $\pm 1/2\%$, whichever is greater. These limits should apply initially and for the duration of the test.

7.3 The combined strain resulting from differential thermal expansion (associated with normal temperature variation of the environment) between the test specimen and the constraint and other variations in the constraint (such as elastic follow up) should not exceed ± 0.000025 in./in. (mm/mm).

7.4 Temperature measurement should be made in accordance with Practice E139.

8. Vibration Control

8.1 Since stress relaxation tests are quite sensitive to shock and vibration, the test equipment and mounting should be located so that the specimen is isolated from vibration.

9. Test Specimens

9.1 The test specimens should be of a shape most appropriate for the testing method and end use. Wire may be tested in the “as-received” condition. Metal plate, sheet, strip, bar, or rod may be machined to the desired shape.

9.2 Residual stresses may significantly alter the stress relaxation characteristics of the material and care should be exercised in machining to prevent alteration of the residual stresses.

9.3 Specimens for testing must have a uniform cross-section throughout the gauge length and meet the following tolerances:

Nominal Diameter or Width	Tolerance, % of Diameter or Width
0.100 in. (2.5 mm)	±0.5
0.250 in. (6.4 mm)	±0.4
0.375 in. (9.5 mm)	±0.3
0.500 in. (12.7 mm)	±0.2

10. Environment

10.1 If the test temperature is different from ambient, specimens previously fitted with strain gages or extensometers should be exposed to the test temperature for a period of time sufficient to obtain dimensional stability before starting the tests.

10.2 The stress relaxation test may be started immediately upon achieving thermal equilibrium.

11. Guide for Processing Test Data

11.1 The remaining stress, relaxed stress, or applied force may be plotted against time or log time. Log stress versus log time plots may also be employed.

11.2 For convenience in comparing the relative relaxation characteristics of materials, the ratio “Fraction Initial Stress Relaxed” may be plotted against time. This ratio is the difference between the initial stress and the remaining stress at any time divided by the initial stress.

12. Report

12.1 The report should include as much of the following information as is appropriate:

12.1.1 Material Being Tested:

- 12.1.1.1 Chemical composition,
- 12.1.1.2 Microstructure,
- 12.1.1.3 Mechanical properties,
- 12.1.2 Specimen geometry,
- 12.1.3 Testing machine or apparatus,
- 12.1.4 Strain measurement method,
- 12.1.5 Temperature measurement method,
- 12.1.6 Atmosphere.

12.1.7 Relaxation Test Data:

- 12.1.7.1 Initial stress and strain data,
- 12.1.7.2 Final stress and strain data,
- 12.1.7.3 Plot of data.

A. METHOD FOR CONDUCTING STRESS RELAXATION TENSION TESTS

13. Scope

13.1 This test method covers the determination of the time-dependent decrease in stress in a specimen subjected to an uniaxial constant tension strain under conditions of uniform environment and negligible vibration. It also includes recommendations for the necessary testing equipment.

14. Summary of Test Method

14.1 The specimen is subjected to an increasing tensile force until the specified initial strain is attained. The initial and remaining stresses are determined by either of the methods in 4.1.

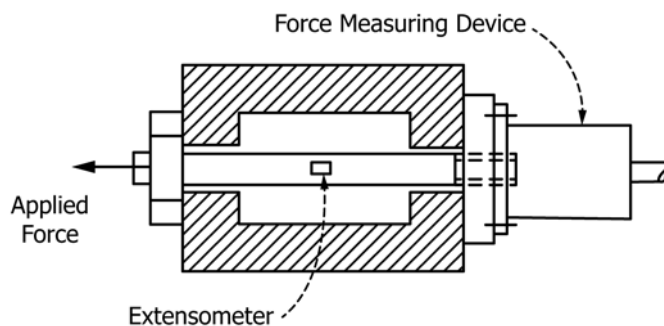

FIG. 3 Tension Stress-Relaxation Test Using Periodic Force Measurement

15. Apparatus

15.1 The testing machine shall have an accuracy of 1 % throughout the working range (see Practices E4), and should be calibrated under both decreasing and increasing force applications.

15.2 The testing machine shall incorporate means of adjusting the force in a continuous and automatic manner in order to maintain constant constraint, so that the strain on the specimen is maintained within ±0.000025 mm/mm (in./in) (see Fig. 3).

15.3 Axiality of force application is extremely important and should be checked using the procedure outlined in Practice E1012. Nonaxiality, so measured, should not exceed 15 % in elastic strain readings.

16. Test Specimens

16.1 Test specimens of the type, size, and shape described in Test Methods E8/E8M and Practice E139 are generally suitable. The cross section should be uniform throughout the length of the reduced section. To facilitate control of the limiting strain, it is preferable that the gauge length be longer than those specified in Test Methods E8/E8M. The following round specimen dimensions, for example, have been used successfully:

Specimen	Gauge Diameter	Gauge Length
1	0.375 in. (9.07 mm)	7.000 in. (177.8 mm)
2	0.375 in. (9.07 mm)	6.000 in. (152.4 mm)
3	0.252 in. (6.40 mm)	4.000 in. (101.6 mm)
4	0.500 in. (12.70 mm)	6.000 in. (152.4 mm)

16.2 Specimens of circular cross-section may have either threaded or shouldered ends for gripping. The threads or shoulders should be concentric with the specimen axis to within + 0.0005 in. (+ 0.01 mm).

16.3 Test specimen surfaces should be smooth and free from nicks and scratches. Eccentricity in the specimen should be minimized and the force should be applied axially. In machining, precautions should be taken to avoid deformation by bending.

17. Grips

17.1 The grips and gripping technique should be designed to minimize eccentric loading in the test specimen.

18. Procedure

18.1 Mount the specimen in the testing machine and minimize axial misalignment. At room temperature, the strain on opposite sides of the test specimen shall not differ from the average by more than 15 %. Attach the thermocouples and extensometer to the specimen. Heat the specimen to the testing temperature, avoid overheating (Section 7), and hold at this temperature for a period sufficient to reach thermal equilibrium and dimensional stability. Apply the initial force rapidly without shock. The start of the test, t_0 , is when the desired test stress is achieved.

18.2 Maintain the limiting strain constant during the duration of the test.

18.3 Any temperature disturbance causing the temperature of the specimen to rise above or below the limits specified in 7.2 is cause for rejection of the test. Exception may be made to this where the time above or below nominal temperature is so short that it will not significantly influence the relaxation characteristics of the material under test.

18.4 After the specified time has elapsed, determine changes in force or stress.

19. Guide for Processing Test Data

19.1 See Section 11.

20. Report

20.1 See Section 12.

21. Precision and Bias

21.1 *Precision*—Sufficient multilaboratory tests have not been performed to establish the reproducibility of this test method. These are long-term tests unsuited for routine testing or for specifications in the purchase of material.

21.2 *Bias*—There is no basis for defining the bias for this test method.

B. METHOD FOR CONDUCTING STRESS RELAXATION COMPRESSION TESTS

22. Scope

22.1 This test method covers the determination of the time-dependent decrease in stress in a specimen subjected to a long duration, uniaxial, constant compression strain in a uniform environment and negligible vibration. It also includes recommendations for the necessary testing equipment.

23. Summary of Test Method

23.1 The specimen is subjected to an increasing compressive force until the specified initial strain is attained. The initial and remaining stress are determined by either of the methods in 4.1.

NOTE 3—Specimen geometry and frictional end effects play an important role in producing a deviation from the idealized specimen deformation. An initially cylindrical specimen ideally would remain a cylinder, but, because of friction, the specimen cross section is larger midway between the platens than at either platen. The slenderness ratio of the specimen recommended in this procedure is intended to minimize such

effects. A more detailed study of these effects is presented by Cook and Larke. (1)⁴

24. Apparatus

24.1 *Apparatus* (Fig. 4)—Similar to that described in Part A, may be used with the following additional requirements. Axiality of force application is extremely important and should be checked using the procedure outlined in Test Methods E9. Nonaxiality upon attaining the specified initial force or strain should not exceed a difference of 10 % in elastic-strain readings on opposite sides of a flat specimen. This difference is measured at the surfaces, which are assumed to be parallel, symmetric to, and as remote as possible from the force application axis. Round specimens shall be measured at three points spaced 120° apart along the circumference.

24.2 *Testing Machine*—This device shall have no instability in compression within the force range being used. The platens of the testing machine shall remain essentially parallel and free of sidewise motion.

24.3 *Bearing Surfaces*—The bearing surfaces of the heads of the testing machine shall be plane, parallel, and maintained in good condition so that there will be substantially no tilting of the bearing blocks throughout the test (see Test Methods E9).

24.4 *Bearing Blocks*—Both ends of a compression specimen shall bear on blocks with surfaces flat and parallel within 0.0002 in./in. (or mm/mm). The bearing blocks shall be made of suitably hard material such that the blocks will suffer no appreciable permanent deformation during the test. Suitable types of bearing blocks are described in Test Methods E9.

24.5 *Alignment Device*—It is desirable to use a suitable alignment device such as that shown in Test Methods E9.

25. Test Specimens

25.1 Test specimens of the type, size, and shape described in Test Methods E9 are generally suitable. Solid circular cylinders with an L/D (length/diameter ratio) of 8 to 10 should be used. In recommending these test specimens, it is not intended to exclude the use of other test specimens of special materials or for special forms of material.

25.2 Sheet or strip specimens described in Test Methods E9 are acceptable when appropriate jigs for lateral support are used.

25.3 Preparation of Specimens:

25.3.1 Specimens for compression stress relaxation tests of metals should be prepared in accordance with Test Methods E9. Care in machining should be exercised so that residual stresses are minimized.

25.3.2 Test specimen surfaces should be smooth and free from nicks and scratches. Special care should be exercised to minimize eccentricity in the specimen. In machining and handling, precautions should be taken to avoid deformation by bending.

⁴ The boldface numbers in parentheses refer to a list of references at the end of this standard.

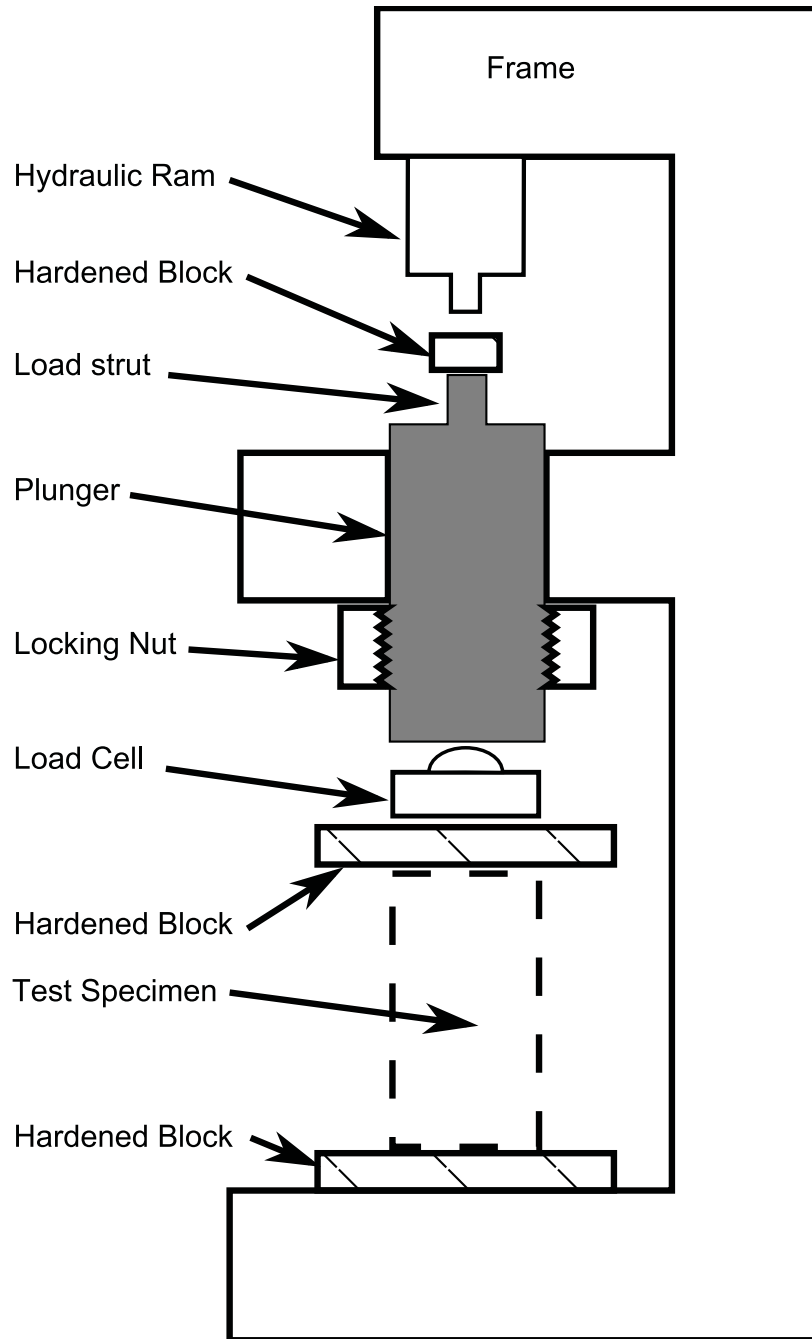

FIG. 4 Compression Stress-Relaxation Test

26. Procedure

26.1 Mount specimen, preferably in an alignment device (see 24.5), minimize axial misalignment, and attach extensometer and thermocouples. Axiality of force application should be in accordance with 24.1. For elevated temperature tests, heat the specimen to the test temperature without overheating (see Section 7). Maintain the specimen at the test temperature for a time sufficient to reach thermal equilibrium and dimensional stability (see 7.3) before applying initial force.

26.2 Apply the initial stress without shock. The rate of force application shall not exceed 690 MPa/min (100 ksi/min). Define the instant that the desired initial test stress is attained as the zero time.

26.3 Maintain the total strain constant within the limits specified in 7.3.

26.4 After the specified time has elapsed, determine the changes in force or stress.

26.5 If the elastic springback (see 4.1.3) is used to determine stress relaxation, remove the stress from the specimen and remove from the test environment. The unrecovered strain is determined and from this the stress relaxation is calculated (see Fig. 3). If it is demonstrable that periodic reloading has no effect on the stress relaxation curve, the same specimen may be repeated force application to the same initial constraint to establish the stress relaxation curve as a function of time (that is, the specimen may be reloaded to the same compressed gauge length as that used immediately upon initial loading). If periodic reloading does affect the shape of the stress relaxation curve, an untested specimen must be used to determine each point on the stress relaxation curve.

27. Guide for Processing Test Data

27.1 See Section 11.

28. Report

28.1 See Section 12.

29. Precision and Bias

29.1 *Precision*—Sufficient multilaboratory tests have not been performed to establish the reproducibility of this test method. These are long-term tests unsuited for routine testing or for specifications in the purchase of material.

29.2 *Bias*—There is no basis for defining the bias for this test method.

C. METHOD FOR CONDUCTING STRESS RELAXATION BENDING TESTS

30. Scope

30.1 This test method covers the determination of the time-dependent decrease in stress in a specimen subject to long duration, constant bending strain, in a uniform environment, and negligible vibration. Recommendations for some typical test equipment are included. Methods included are only those in which the outer fiber strain is essentially uniform in the test section.

31. Summary of Test Method

31.1 The specimen is subjected to an increasing bending moment until the specified initial maximum bending strain is attained. The initial and remaining bending stresses are determined from either of the methods shown in 4.1.

31.1.1 *Test Method C-1*—Readings are taken from a continuously reading force indicator while the apparatus adjusts the force to maintain constraint within specified bounds (see 4.1.1).

31.1.2 *Test Method C-2*—The force required to lift the specimen just free of one or more constraints during the test period is measured (see 4.1.2).

31.1.3 *Test Method C-3*—Elastic springback upon removal of stress at the end of the test period is measured (see 4.1.3).

31.2 With Test Methods C-1 and C-2, a single specimen can be used to obtain data for a curve of stress versus time. With Test Method C-3, the same specimens may be used to determine the remaining or relaxed stress with time, if it can be

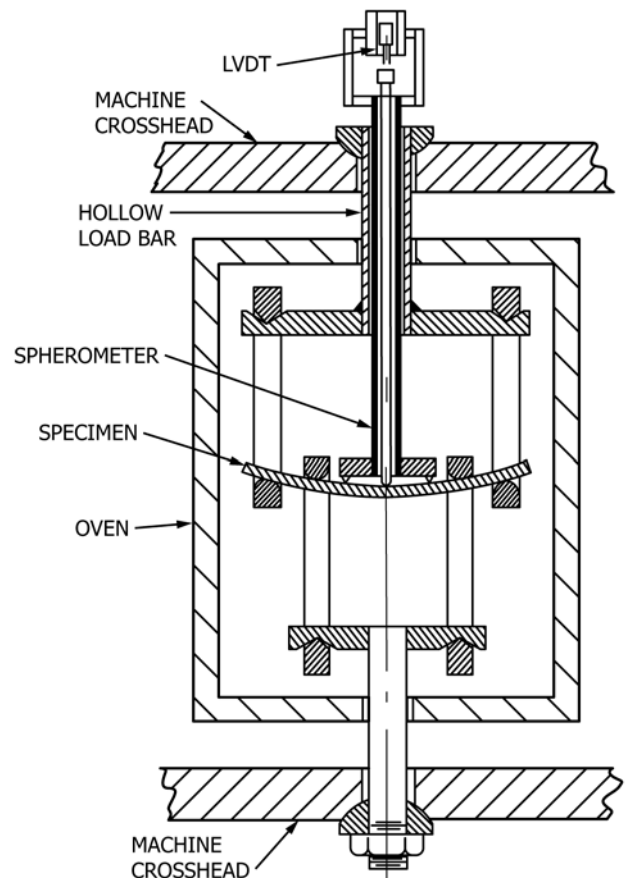

FIG. 5 Specimen and Spherometer in Four-Point Flexural Stress Fixture

demonstrated that identical results are obtained using either untested or previously stressed specimens. Otherwise, individual specimens must be used for each point on the curve.

32. Apparatus

32.1 The apparatus consists of equipment for maintaining the test environment, and applying, maintaining, and measuring the restraining force.

32.2 The test environment shall be maintained by apparatus that conforms to the conditions specified in Sections 7, 8, and 10.

32.3 Test Method C-1:

32.3.1 The force (or moment) adjusting apparatus consists of a device that applies and indicates the force or moment and measures specimen deflection (see Fig. 5).

32.3.2 The fixtures for testing the specimen shall be of the four-point flexural stress type shown in Fig. 5. The force bearing points should be symmetrical about the mid-span so that the central portion of the specimen is in uniform bending with a uniform outer fiber stress.

32.3.3 The maximum permissible variation in specimen strain during the force (or moment) adjusting process shall not exceed the elastic strain corresponding to a 1 % change in initial stress.

32.3.4 The force required to move the spherometer and transducer should be in accordance with 32.3.3.

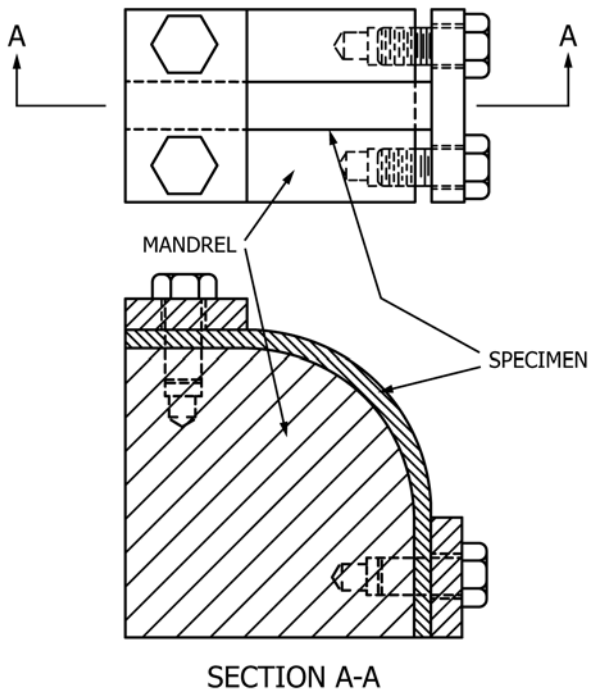

FIG. 6 Specimen in Mandrel-Type Fixture

32.3.4.1 *Calibration of Spherometer*—The strain (or curvature) control device shall meet the following qualifying test: an auxiliary specimen, having the same dimensions as the test specimen, shall be instrumented with electrical strain gages. It shall be flexed at room temperature with the test apparatus to the maximum deflection (minimum radius of curvature) of the test program. The change in strain of the auxiliary specimen during the adjusting process of the apparatus shall not exceed the elastic strain corresponding to a 1 % change in the initial stress. The latter value may be estimated by dividing the initial maximum outer fiber stress as calculated from the conventional beam equations (see 35.5.1) by the elastic modulus of the material.

32.3.4.2 Choose the specimen material for the qualifying test so that its change of curvature due to relaxation is at least equal to the change expected during the test program (change of curvature after removal of the stress test).

32.4 *Test Methods C-2 and C-3:*

32.4.1 Static fixtures are used to maintain the specimen curvature constant within the bounds specified, such as clamps which constrain a wire or strip specimen into a circular arc (2) or mandrel (see Fig. 6) or an end fixed tapered (constant curvature) cantilever with the force applied to the opposite end(3) for strip (see Fig. 7). For specimens flexed as a circular arc, the arc length should be at least 20× the specimen thickness.

32.4.2 *Test Method C-2*—Sufficient force is periodically applied to the specimen at a point of contact to lift the specimen slightly clear of its static constraint. Relaxation in moment or stress is calculated from the lift-off force.

32.4.3 *Test Method C-3*—The specimen’s constraint is maintained during the test interval. The relaxation in moment

or stress is calculated from the elastic springback after removal of the test stress (see Fig. 6).

32.4.4 The complexity of the static fixture will depend on whether data are required at times that are short relative to the time required for the apparatus and fixtures to come to equilibrium with the environment.

32.4.4.1 When short-time data are required, the apparatus should permit the stress to be applied and then removed from specimen and curvature to be measured while the specimen is in the test environment.

32.4.4.2 When short-time data are not required, the stress may be applied to and removed from specimens while the static fixture is at room temperature. The loaded fixture is then transferred to the test environment for exposure. During heating or cooling, the mismatch of thermal expansion of the specimens and fixtures should not produce a bending strain greater than 1 % of the elastic-strain corresponding to the initial stress.

33. Test Specimens

33.1 In general, specimens should be of the same thickness and surface condition as the stock being evaluated.

33.2 The width of the specimen should be determined after considering three factors:

33.2.1 Specimens of uniform width are suitable when the force is applied through a symmetrical, four-point flexural stress fixture or a mandrel is used (see Figs. 5 and 6).

33.2.2 Straight tapered edges that extend almost to the force bearing points are suitable when force is applied to the specimen as a simple cantilever beam or as a simply-supported, beam with the force applied to the center (see Fig. 7).

33.2.3 Wires and other shapes of approximately equal depth and width should usually be tested using their original cross-sectional dimensions.

33.3 The specimen length should be chosen such that the deflections are large enough to be easily measured, but not so large that the friction forces and changes in direction of the normal forces cause significant errors in the bending moment. More specific guides are as follows:

33.3.1 The length in contact with the constant-radius portion of a mandrel should be at least 20× the thickness of the specimen to assure conformity and avoid end effects.

33.3.2 When a mandrel is not used, the distance between force bearing points in the constant-curvature portion should be at least ten times the thickness to avoid undue influence from stress concentration due to the contact forces.

33.3.3 When a mandrel is not used, the length of uniform curvature should permit the use of a spherometer span greater than $2\sqrt{rh}$ where r is the ratio of the strain sensitivity of the spherometer to the acceptable strain variation, and h is the specimen thickness.

33.3.4 When the points through which the force is applied to the specimen and the supporting points are rigidly attached to the test frame so that they cannot tilt or displace longitudinally, the ratio of specimen length to thickness should be less than 200 for four-point flexurally stressed beams and less than 100 for end-stressed cantilever beams.

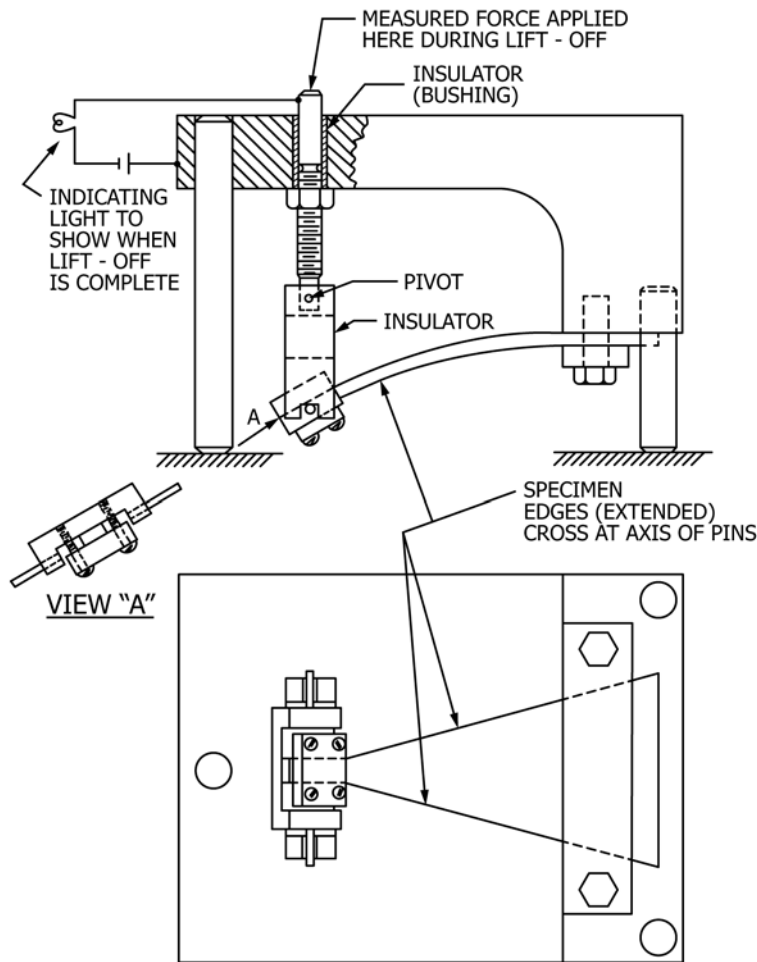

FIG. 7 Specimen in Static Fixture for Lift-Off Force Measurement

33.4 The corners at the edges of the specimen may be rounded to a radius that shall not exceed one tenth of the specimen thickness. Test specimen surfaces should be smooth and free of nicks and scratches. Precautions should be taken to avoid deformation or heating when machining specimens.

33.5 The test specimens shall not be twisted.

NOTE 4—Bending tests to determine relaxation properties by using ring-shaped specimens machined from bulk material have been thoroughly developed and widely used) to determine relaxation properties(4. These are considered to be outside the scope of this document.

34. Procedures

34.1 Relaxation test conditions should be specified in terms of a strain rather than initial stress.

34.2 Test Method C-1:

34.2.1 The test specimen, which is designed to produce a constant curvature in the gauge length (see Fig. 5), is stressed in flexure as a four-point beam. A displacement transducer or spherometer senses small changes in specimen curvature (or strain) due to relaxation of the specimen's internal bending moment and controls the machine crosshead to maintain the specimen's curvature or strain constant.

34.2.2 Assemble the specimen into the test fixture and properly align. Carefully measure the specimen and positions of force application to assure symmetry of stress distribution. Make sure that the loading edges contact the specimen uniformly across its entire width. Apply the test force as quickly as possible without causing transient impact stresses. As the final increment of force is applied, start the recording of time, load, curvature, and temperature. If deflections are large, note the slope of the specimen and direction of the line of action of force at contact points.

34.3 Test Methods C-2 and C-3:

34.3.1 Several fixtures can be used simultaneously that hold the curvature constant to develop curves of either remaining stress or relaxed stress versus time. Start recording time and temperature when the force application is completed for room-temperature tests. At an elevated temperature, the time starts when the test specimen reaches temperature and dimensional stability. Periodically measure the curvature of the specimen immediately after removal of the test stress. This change in curvature is called springback. From this measurement the remaining stress may be calculated as described in Section 35.

34.3.2 If long-time tests are to be made at elevated temperatures, using static fixtures the stress test may be applied at room temperature just before being placed in the testing environment. After exposure to the testing environment, they may be removed for measurement of springback or lift-off force. Make these measurements immediately after the temperature of the specimen and fixture stabilize. If lift-off is measured and the test is to be continued, do not remove that specimen and fixture from the testing environment again until a time equal to or greater than the preceding time interval has elapsed.

35. Calculation and Presentation of Results

35.1 Strain is defined as that quantity equal to the distance from the neutral axis of the specimen to the outer fiber, divided by the radius of the curvature of the neutral axis. For specimens of symmetrical cross section, the strain is:

$$\text{Strain} = h/(2R_i + h) \quad (1)$$

$$\text{Strain} = h/(2R_o - h) \quad (2)$$

where:

- h = specimen thickness, in. (mm),
- R_i = radius of the concave surface of the specimen, in. (mm), and
- R_o = radius of the convex surface of the specimen, in. (mm).

Use (Eq 1) when the specimen is forced to conform to a mandrel. (Eq 2) is convenient when a spherometer is used to measure strain and is in contact with the convex surface of the specimen.

35.2 When the restraining force is known, the ratio of remaining stress to initial stress (defined in 3.1.2) is equal to the restraining force at any time, divided by the initial restraining force. When the springback method (4.1.3) is used, (Eq 1) and (Eq 2) are used to calculate strain after removal of the test stress. The ratio of remaining stress to initial stress is equal to the ratio of the elastic strain on removal of the test stress to the initial strain.

35.3 The extent of relaxation may be expressed as a dimensionless quantity of force, stress, bending moment, or springback. It is equal to the change during a specified time interval divided by a previously determined value.

35.4 When stress values are reported, the equations used shall be stated. The derivation shall be included in the report or a reference cited that shows the derivation. When (Eq 3) and (Eq 4) are used (see 35.5.1), the section numbers may be used as the reference.

35.5 If the restraining force is measured, the elastic flexure equation, Eq 3, should be used to calculate initial stress and these values should be reported as nominal flexure stress on application of the test force. However, these values will be correct only if the stress remains proportional to strain. The following sections describe analytical tests for applicability of the elastic flexure equation and a method of bounding the stress values if the equation is not directly applicable. The elastic flexure equation is applicable for specimens that have line

contact at points of known force. It is not applicable when the specimen is restrained by a mandrel.

35.5.1 The elastic flexure equation is:

$$\sigma = Mc/I \quad (3)$$

where:

- σ = nominal flexure stress at the outer fiber,
- M = bending moment at the most highly stressed section,
- c = distance from outer fiber to centroid axis of the cross section, and
- I = moment of inertia about the centroid axis of the cross section.

For rectangular cross sections,

$$c/I = 6/bh^2 \quad (4)$$

where:

- b = width of the beam (the dimension normal to the plane of the applied forces), and
- h = thickness of the beam (the dimension in the plane of the applied forces).

NOTE 5—The bending moment in Eq 3 has its usual definition, but the large deflections and slopes that may occur in testing thin strip may require some modification of Eq 3.(5)

35.6 When lift-off force or springback measurements are made at room temperature and the test environment is at an elevated temperature, the stress value at room temperature should be multiplied by the ratio of the modulus of elasticity at the test temperature to that at room temperature, to correct for the temperature dependence of the modulus of elasticity. Since plastic strains are temperature-dependent, the stress value before exposure to the test temperature should not be reported as initial stress. The first reported stress value should be based on measurements made after exposure to the testing environment long enough for the specimen and fixture to attain the test temperature. These measurements should be made within an insignificant period relative to the total time at test temperature.

35.7 Stress calculations for all tests of one series should be made using similar measurements and equations.

36. Interpretation of Results

36.1 Various complexities and qualifications should be kept in mind when the values of bending stress are used. Bending, tensile or compressive stresses are usually reported as though residual stress or anisotropy is not present. All of these may have large effects, particularly, in the case of thin sheets and wires.

36.2 The state of stress in bending is variable and difficult to describe even in the elastic case. In addition to the variation of stress due to differing thicknesses, significant transverse stress variations are also present. These are readily calculated only for narrow beams or very wide beams at regions not near the edges.(5) The situation is further complicated by the variable width encountered in cantilever or specimens where force is applied to the center. Except in the case of four-point applied load, the shear stress also varies along the test section.

36.3 The basic assumption in determining remaining stress is that the outer fiber stress is proportional to the bending moment. This assumption is correct if the stress at each point

in the beam is a constant fraction of the outer fiber stress. If during relaxation, the fraction relaxed is constant for a specified time, the stress is independent of the level of initial strain. This relationship is approximately true for a variety of materials.(3),(6) Relaxation tests should be made at two levels of strain whenever possible to verify this assumption.

37. Report

37.1 Most test results will be influenced by the method of force application and specimen form. Therefore, the report should include sufficient dimensional and other information to permit a reader to judge the influence of specimen dimensions and force application on the results. Since stress has been and will continue to be calculated in different ways, sufficient primary data should be included so values can be calculated by each of the alternative methods. The following sections include items to be in the report:

37.1.1 Direction of measured forces and whether direction is measured or assumed.

37.1.2 Temperature at which lift-off force or springback measurements were made. If other than the test temperature, include the value of the ratio of the modulus of elasticity at the two temperatures.

37.1.3 Plot of fraction relaxed force, moment, springback, or stress at an arbitrarily chosen reference time at least ten times the loading time. This plot should compare tests at several different stress conditions.

37.1.4 Equations used for all calculations of stress.

37.1.5 Nominal elastic stress on initial force application and the value of the modulus of elasticity used. For wide specimens, include the Poisson's ratio used.

37.1.6 Nominal flexural stress on application of test force (see 35.5.1).

37.1.7 Plot showing estimate of upper and lower limits of remaining stress if nominal elastic and flexure stresses are not equal.

38. Precision and Bias

38.1 *Precision*—Sufficient multilaboratory tests have not been performed to establish the reproducibility of this test method. Although documentation (7) of a round robin test involving three laboratories testing two alloys show the results are within 10 %. These are long-term tests unsuited for routine testing or for specifications in the purchase of material.

38.2 *Bias*—There is no basis for defining the bias for this test method.

D. METHOD FOR CONDUCTING STRESS RELAXATION TORSION TESTS

39. Scope

39.1 This test method covers the determination of the time-dependent decrease in torsional stress in a specimen subjected to long duration, constant torsional strain in a uniform environment and negligible vibration. Recommendations for some typical test equipment are included. The test method applies when the outer fiber strain is essentially uniform in the test section.

40. Summary of Test Method

40.1 The specimen is subjected to an increasing axial torque until the specified initial torsional strain is attained. The resulting angle of twist is maintained essentially constant for the duration of the test while the specimen is in the testing environment. The test method of determining initial and remaining stress depends on the type of specimen used; it may generally be calculated from the initial and remaining torque on the specimen.

41. Apparatus

41.1 The apparatus consists of equipment to perform five functions: maintain the test environment, apply the restraining torque, determine when the specified strain has been attained, adjust the restraining torque to maintain the specified strain, and measure the restraining torque.

41.2 Apparatus to maintain the test environment shall conform to the conditions specified in Section 7, 8, and 10.

41.3 The recommended apparatus to apply and maintain conditions of constant restraint is a torque-adjusting apparatus. This usually consists of a torsion-testing machine to apply and indicate the torque resisted by the specimen, and a means (for example, an angular displacement transducer) to measure and control the displacement.

41.3.1 The testing machine and control systems shall conform to Section 7 of this method except that the permissible variation in strain shall not exceed + 1 %.

41.3.2 The clamping heads shall be coaxial, with one head easily displaceable in the direction of the specimen's axis. Bending and axial strains in the specimen shall not exceed 1 % of the specified torsional strain.

NOTE 6—This may be verified with a specimen similar to the test specimen which has been instrumented with strain gages and torqued, at room temperature, to the specified torsional strain.

41.3.3 The type of specimen grips used shall be such that all but torsional stresses are minimized. For specimens of uniform cross section, collet-type grips should be used. For machined specimens of larger diameter, oversized ends are preferred.

41.3.4 The control device shall be sufficiently sensitive so the change in strain during relaxation shall not exceed + 1 % of the specified strain.

41.3.5 Members that transmit forces to or around specimens should be sufficiently massive so that their deformations are insignificantly small compared with the deformation of the specimen.

41.4 The apparatus for taking measurements from which torsional strains can be calculated should determine the angle of twist of the specimen over a length where the outer fiber stress is nominally uniform. Alternatively, strain gage rosettes cemented to the specimen may be used if it has been demonstrated that the gages remain accurate to within + 1 % of the specified strain for all the test conditions, time, temperature, strain, and specimen materials. Errors due to creep of gage cement should be avoided.

41.4.1 The use of electric resistance strain gauges for the monitoring of strain during a test should not be used for specimens having diameters or wall thicknesses less than 20x

the thickness of the gage, because the gage and cement can significantly stiffen the specimen.

42. Test Specimens

42.1 Test specimens may be in the form of circular cylinders or tubes. In general, specimens should be of the same diameter and surface condition as the part being evaluated, but nicks and scratches should be avoided, particularly in the gauge section.

42.2 To minimize end effects, a minimum length-to-diameter ratio should be at least twenty, but the ratio should not be sufficiently high as to allow buckling to occur in the test specimen.

42.3 The longitudinal axis of the specimen shall be straight before application of test torque.

43. Procedure

43.1 Relaxation test conditions should be specified in terms of strain rather than initial stress. Specifying strain has certain advantages. Torsional strain is a less ambiguous quantity than torsional stress, because the assumptions used to measure strain are less contentious than those to calculate stress, especially when plastic strains occur. Also, if plastic strains occur, the initial stress may depend on the loading procedure and therefore cannot be uniquely specified.

43.2 Mount the specimen into the clamping heads, exercising precautions to minimize axial misalignment, and attach the angular displacement transducer. In tests at elevated temperatures, heat the specimen to the test temperature, being careful to avoid overheating (see Section 7). Before applying torque, maintain the specimen at the test temperature for a period sufficient to reach thermal equilibrium and dimensional stability in accordance with 7.3. Record the exposure time.

43.3 Start the torque, twist, and temperature recorders before applying the initial torque to ensure their stability. Apply the initial torque rapidly but without shock, in accordance with 6.1, noting the rate of twist (or torque) employed. The instant the desired angle of twist (or torque) is attained is considered time zero.

43.3.1 If a torque-adjusting servomechanism is used, the angular displacement transducer shall activate the torque-reducing mechanism at the instant the desired angle of twist (or torque) is attained.

43.4 Maintain the limiting angle of twist constant during the test.

43.5 Record the change in torque at constant angle of twist.

43.6 At completion of the test, record the torque versus twist relation on removal of test torque.

44. Calculation and Presentations of Results

44.1 Strain will be taken as equal to the angle of twist per unit length, multiplied by the radius of the specimen.

44.2 The initial maximum torsional stress may be calculated as follows:

44.2.1 Obtain a torque versus angle-of-twist-per-unit-length curve up to the desired angle of twist.

44.2.2 If the curve is linear, use the following equations:

44.2.2.1 For a cylindrical specimen:

$$\tau_0 = \frac{16T_0}{\pi d^3} \quad (5)$$

where:

τ_0 = initial maximum torsional stress,
 T_0 = initial torque, and
 d = specimen diameter.

44.2.2.2 For a tubular specimen:

$$\tau_0 = \frac{16T_0 d_0}{\pi(d_0^4 - d_i^4)} \quad (6)$$

where:

d_0 = specimen outside diameter, and
 d_i = specimen inside diameter.

44.2.3 If the torque-twist curve is nonlinear, the initial maximum torsional stress can be estimated for a cylindrical specimen or for a thin-walled tubular specimen.

44.2.3.1 For a cylindrical specimen:**(8)**

$$\tau_0 = \frac{4(3T_0 + \theta\alpha)}{\pi d^3} \quad (7)$$

where:

θ = angle of twist per unit length at torque T_0 , and
 α = slope of the torque-twist curve at torque τ_0 .

44.2.3.2 For a thin-walled tubular specimen, the initial maximum torsional stress may be approximated by the equation given in 44.2.2.2.

NOTE 7—The error involved in this approximation is always less than the ratio t/d_0 , where t is the wall thickness. For example, if t/d_0 is 0.05, the error is less than 5 %.

44.3 The accuracy with which the remaining torsional stress may be determined, at any instant, depends upon the nature of the specimen.

44.3.1 For a thin-walled tubular specimen, the remaining torsional stress may be approximated by:

$$\tau = \frac{16Td_0}{\pi(d_0^4 - d_i^4)} \quad (8)$$

where:

τ = remaining maximum torsional stress, and
 T = remaining torque.

NOTE 8—The error of this approximation does not exceed that described in Note 7.

44.3.2 The calculation of the remaining torsional stress in cylindrical or thick-walled tubular specimens requires an assumption that the fraction of initial torque that is relaxed during any time interval is independent of strain. As one test of this assumption, one of these fractions should be calculated for each strain level tested. The time interval used as the denominator of the ratio should be the same for all tests. If the fractions for various strains do not agree within the estimated accuracy of the measurement or the reproducibility of duplicate tests, the assumption is questionable.

44.3.2.1 If the assumption appears to be valid, the ratio of remaining stress to initial stress may be taken as equal to the

restraining torque at any time during the test, divided by the restraining torque at the instant of reaching the strain value subsequently held constant.

44.3.2.2 If the assumption cannot be justified, then the variation with time of restraining torque should be reported rather than torsional stresses of unknown accuracy.

44.4 When stress values are reported, the equations used shall be stated. The derivation shall be included in the report or a reference cited that shows the derivation.

44.5 If any values of stress are reported, the product of strain and modulus of rigidity at the test temperature should also be reported and called “nominal elastic stress on application of test torque.” The value of the modulus and its source should be included in the report. The nominal elastic stress on application of test torque is not always the best estimate of initial stress, but it is useful for arriving at a better estimate and judging the probable error.

44.6 The results shall be presented as curves of remaining stress (or torque) versus time or log time. Log stress (or torque) versus log time plots may also be used.

44.7 For convenience in comparing the relative relaxation characteristics of materials, the ratio “Fraction Initial Stress

Relaxed” may be plotted against time. This ratio is the difference between the initial stress and the remaining stress at any time, divided by the initial stress. The ratio “Fraction Initial Torque Relaxed” is useful for comparing the relative relaxation characteristics of materials only if all of the materials were tested at the same specified strain levels, or at the same initial torques, and with the same specimen dimensions.

45. Report

45.1 See Section 12.

46. Precision and Bias

46.1 *Precision*—Sufficient multilaboratory tests have not been performed to establish the reproducibility of this test method. These are long-term tests unsuited for routine testing or for specifications in the purchase of material.

46.2 *Bias*—There is no basis for defining the bias for this test method.

47. Keywords

47.1 bending relaxation; bolting; compression relaxation; hoop stresses; riveting; springs; stress relaxation; tension relaxation; torsion relaxation

REFERENCES

- (1) Cook, M. and Larke, E. C., “Resistance of Copper Alloys to Homogeneous Deformation in Compression,” *Journal of the Institute of Metals*, London, Vol 71, 1945, p. 371–390.
- (2) Fox, Alfred, “A Simple Test for Evaluating Stress Relaxation in Bending,” *Materials Research and Standards*, Vol 4, No. 9, September 1964, pp. 480–481.
- (3) Fox, Alfred, “The Effect of Extreme Cold Rolling on the Stress Relaxation Characteristics of CDA Copper Alloy 510 Strip,” *Journal of Materials*, Vol 6, No. 2, June 1971, pp. 422–435.
- (4) Oding, I. A., ed. *Creep and Stress Relaxation in Metals*, Oliver and Boyd, Edinburgh, Scotland, 1965, pp. 252–279.
- (5) Timoshenko and Woinowsky-Krieger, *Theory of Plates and Shells*, 2nd ed., McGraw-Hill Book Co., New York, NY 1959.
- (6) Borzdyka, A. M., “Elevated-Temperature Testing of Metals,” Israel Program for Scientific Translations, 1965, pp. 227–241.
- (7) Parikh, P., “Report on Bending Stress Relaxation Round Robin” in Alfred Fox, “Stress Relaxation Testing,” *ASTM STP 676*, ASTM pp. 112–125. DOI: <http://dx.doi.org/10.1520/STP676-EB>
- (8) Nadai, A., *Theory of Flow and Fracture of Solids*, 2nd ed., Vol I, McGraw-Hill Book Co., Inc., New York, NY 1950, pp. 347–349.

SUMMARY OF CHANGES

Committee E28 has identified the location of selected changes to this standard since the last issue (E328–02(2008)) that may impact the use of this standard.

- (1) Section 3 was revised.
- (2) Corrected minor terminology and grammar issues.
- (3) Updated the reference list to make it more useful.
- (4) Redrew Fig. 1, to improve clarity.
- (5) Removed previous Figure 2, which was not referenced in the text.
- (6) Removed previous Figure 3, which did not illustrate what the text states.
- (7) Redrew Fig. 2 to illustrate what is written in the text.
- (8) Redrew Fig. 4.
- (9) Correct usage of “gage” to “gauge” as required by E28.
- (10) Converted Note 7 to a numbered section because it contains the word “shall.”
- (11) Replaced several occurrences of “is recommended” with “should.”

ASTM International takes no position respecting the validity of any patent rights asserted in connection with any item mentioned in this standard. Users of this standard are expressly advised that determination of the validity of any such patent rights, and the risk of infringement of such rights, are entirely their own responsibility.

This standard is subject to revision at any time by the responsible technical committee and must be reviewed every five years and if not revised, either reapproved or withdrawn. Your comments are invited either for revision of this standard or for additional standards and should be addressed to ASTM International Headquarters. Your comments will receive careful consideration at a meeting of the responsible technical committee, which you may attend. If you feel that your comments have not received a fair hearing you should make your views known to the ASTM Committee on Standards, at the address shown below.

This standard is copyrighted by ASTM International, 100 Barr Harbor Drive, PO Box C700, West Conshohocken, PA 19428-2959, United States. Individual reprints (single or multiple copies) of this standard may be obtained by contacting ASTM at the above address or at 610-832-9585 (phone), 610-832-9555 (fax), or service@astm.org (e-mail); or through the ASTM website (www.astm.org). Permission rights to photocopy the standard may also be secured from the Copyright Clearance Center, 222 Rosewood Drive, Danvers, MA 01923, Tel: (978) 646-2600; <http://www.copyright.com/>