



# Standard Test Method for Measuring Surface Frictional Properties Using the British Pendulum Tester<sup>1</sup>

This standard is issued under the fixed designation E303; the number immediately following the designation indicates the year of original adoption or, in the case of revision, the year of last revision. A number in parentheses indicates the year of last reapproval. A superscript epsilon ( $\epsilon$ ) indicates an editorial change since the last revision or reapproval.

## 1. Scope

1.1 This test method covers the procedure for measuring surface frictional properties using the British Pendulum Skid Resistance Tester.<sup>2</sup> A method for calibration of the tester is included in the Annex.

1.2 The British Pendulum Tester is a dynamic pendulum impact-type tester used to measure the energy loss when a rubber slider edge is propelled over a test surface. The tester is suited for laboratory as well as field tests on flat surfaces, and for polish value measurements on curved laboratory specimens from accelerated polishing-wheel tests.

1.3 The values measured, BPN = British Pendulum (Tester) Number for flat surfaces and polish values for accelerated polishing-wheel specimens, represent the frictional properties obtained with the apparatus and the procedures stated herein and do not necessarily agree or correlate with other slipperiness measuring equipment.

1.4 The values stated in SI units are to be regarded as the standard. The values given in parentheses are for information only.

1.5 *This standard does not purport to address all of the safety concerns, if any, associated with its use. It is the responsibility of the user of this standard to establish appropriate safety and health practices and determine the applicability of regulatory limitations prior to use.*

## 2. Referenced Documents

2.1 *ASTM Standards:*<sup>2</sup>

**E501 Specification for Rib Tire for Pavement Skid-Resistance Tests**

<sup>1</sup> This test method is under the jurisdiction of ASTM Committee E17 on Vehicle - Pavement Systems and is the direct responsibility of Subcommittee E17.23 on Surface Characteristics Related to Tire Pavement Slip Resistance.

Current edition approved July 1, 2013. Published September 2013. Originally approved in 1961. Last previous edition approved in 2008 as E303 – 93 (2008). DOI: 10.1520/E0303-93R13.

<sup>2</sup> For referenced ASTM standards, visit the ASTM website, [www.astm.org](http://www.astm.org), or contact ASTM Customer Service at [service@astm.org](mailto:service@astm.org). For *Annual Book of ASTM Standards* volume information, refer to the standard's Document Summary page on the ASTM website.

## 3. Summary of Test Method

3.1 This test method consists of using a pendulum-type tester with a standard rubber slider to determine the frictional properties of a test surface.

3.2 The test surface is cleaned and thoroughly wetted prior to testing.

3.3 The pendulum slider is positioned to barely come in contact with the test surface prior to conducting the test. The pendulum is raised to a locked position, then released, thus allowing the slider to make contact with the test surface.

3.4 A drag pointer indicates the British Pendulum (Tester) Number. The greater the friction between the slider and the test surface, the more the swing is retarded, and the larger the BPN reading. Four swings of the pendulum are made for each test surface.

## 4. Significance and Use

4.1 This test method provides a measure of a frictional property, microtexture, of surfaces, either in the field or in the laboratory.

4.2 This test method may be used to determine the relative effects of various polishing processes on materials or material combinations.

4.3 The values measured in accordance with this method do not necessarily agree or directly correlate with those obtained utilizing other methods of determining friction properties or skid resistance.

NOTE 1—BPN and polish values from similar types of surfaces will not be numerically equal, primarily because of the differences in slide length and surface shape. Theoretical correction of the polish values to obtain numerical equality, either by mathematical manipulation or by use of special measuring scales is not recommended.

## 5. Apparatus

5.1 *British Pendulum Tester (Fig. 1)*—The pendulum with slider and slider mount shall weigh  $1500 \pm 30$  g. The distance of the center of gravity of the pendulum from the center of oscillation shall be  $411 \pm 5$  mm ( $16.2 \pm 0.2$  in.). The tester shall be capable of vertical adjustment to provide a slider contact path of  $125 \pm 1.6$  mm ( $4^{15/16} + 1/16$  in.) for tests on flat surfaces, and 76 to 78 mm ( $3 \pm 1/16$  in.) for tests on

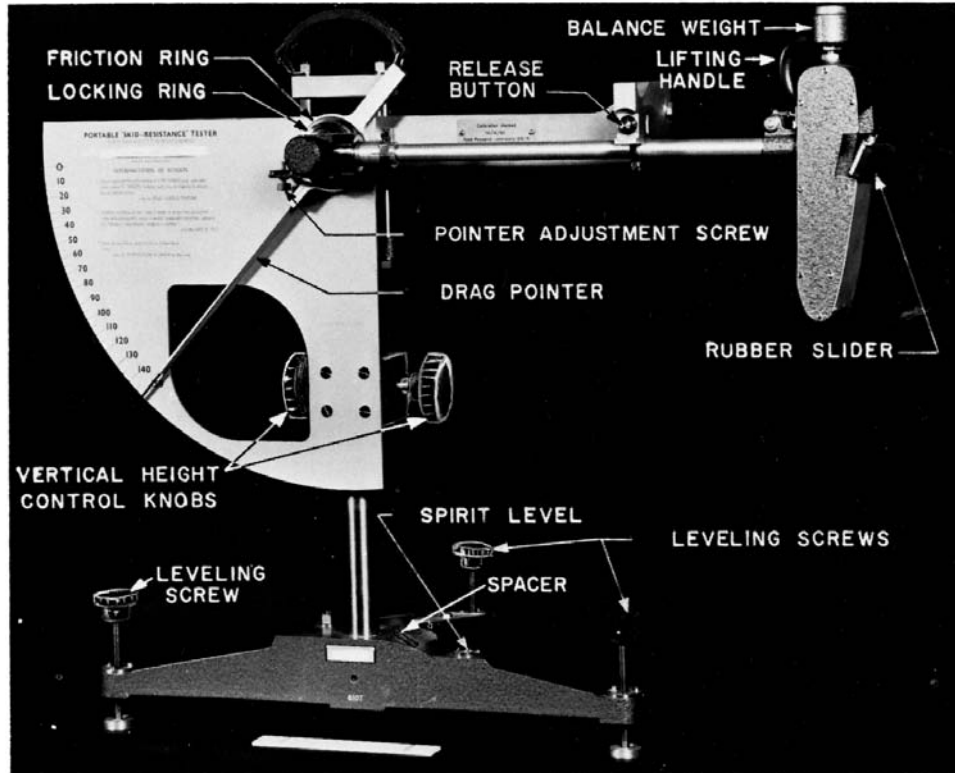

FIG. 1 British Pendulum Tester

polishing-wheel specimens. The spring and lever arrangement shown in Fig. 2 shall give an average normal slider load between the 76-mm (3-in.) wide slider and test surface of  $2500 \pm 100$  g as measured by the method prescribed in the annex.

5.2 *Slider*—The slider assembly shall consist of an aluminum backing plate to which is bonded a 6 by 25 by 76-mm ( $\frac{1}{4}$  by 1 by 3-in.) rubber strip for testing flat surfaces or a 6 by 25 by 32 mm ( $\frac{1}{4}$  by 1 by  $1\frac{1}{4}$ -in.) rubber strip for testing curved polishing-wheel specimens. The rubber compound shall be natural rubber meeting the requirements of the Road Research Laboratory<sup>3</sup> or synthetic rubber as specified in Specification E501.

5.2.1 New sliders shall be conditioned prior to use by making ten swings on No. 60 grade silicon carbide cloth<sup>4</sup> or equivalent under dry conditions. The swings shall be made with a tester adjusted as in Section 7.

<sup>3</sup> Giles, C. G. Sabey, Barbara E., and Carden, K. W. F., "Development and Performance of Portable Skid-Resistance Tester," *Road Research Technical Paper No. 66*, Road Research Laboratory, Dept. of Scientific and Industrial Research, England, 1964.

Kummer, H. W. and Moore, D. F. "Concept and Use of the British Portable Skid-Resistance Tester," *Report No. 6*, PDH-PSV Joint Road Friction Program, Dept. of Mechanical Engineering, The Pennsylvania State University, State College, PA 16802, June 1963.

<sup>4</sup> The sole source of supply of the apparatus known to the committee at this time is available from 3 M Co., St. Paul, MN, under the trade name of Type B Safety-Walk. If you are aware of alternative suppliers, please provide this information to ASTM International Headquarters. Your comments will receive careful consideration at a meeting of the responsible technical committee,<sup>1</sup> which you may attend.

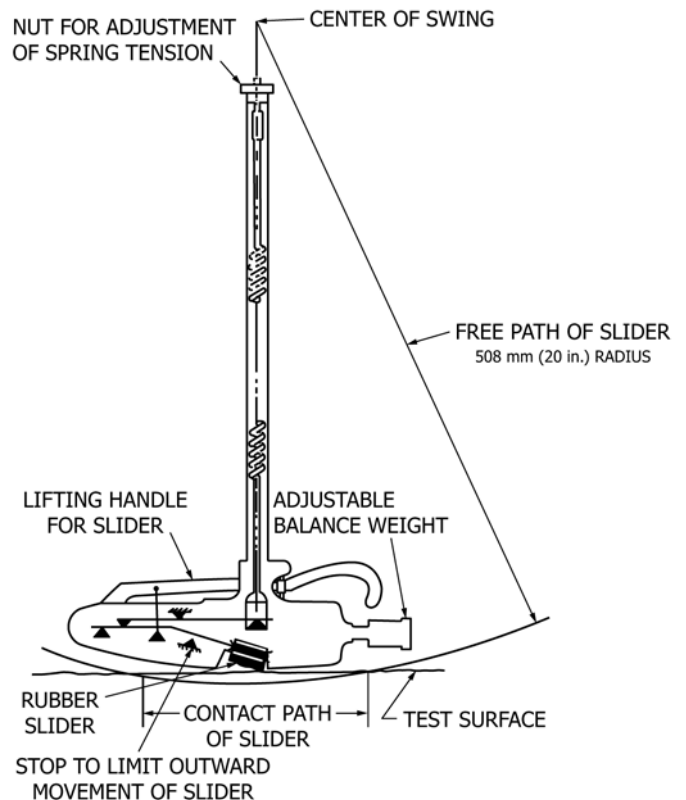

FIG. 2 Schematic Drawing of Pendulum Showing Spring and Lever Arrangement

5.2.2 Wear on the striking edge of the slider shall not exceed 3.2 mm (1/8 in.) in the plane of the slider or 1.6 mm (1/16 in.) vertical to it, as illustrated in Fig. 3.

5.3 Accessories:

5.3.1 Contact path gage shall consist of a thin ruler suitably marked for measuring contact path length between 124 and 127 mm (4 7/8 and 5.0 in.) or between 75 and 78 mm (2 15/16 and 3 1/16 in.) as required for the particular test.

5.3.2 Miscellaneous equipment, such as water container, surface thermometer, and brush is recommended.

6. Test Specimen

6.1 Field—Field test surfaces shall be free of loose particles and flushed with clean water. The test surface does not have to be horizontal provided the instrument can be leveled in working position using only the leveling screws and the pendulum head will clear the surface.

6.2 Laboratory—Laboratory test panels shall be clean and free of loose particles and shall be held rigidly so as not to be moved by the force of the pendulum.

6.2.1 Flat laboratory test panels shall have a test surface of at least 89 by 152 mm (3 1/2 by 6 in.).

6.2.2 Accelerated laboratory polishing-wheel specimens shall have a test surface of at least 44 by 89 mm (1 3/4 by 3 1/2 in.) and shall be curved in the arc of a circle 406 mm (16 in.) in diameter.

7. Preparation of Apparatus

7.1 Leveling—Level the instrument accurately by turning leveling screws until the bubble is centered in the spirit level.

7.2 Zero Adjustment— Raise pendulum mechanism by loosening locking knob (directly behind pendulum pivot) and turn either of pair of head movement knobs at center of tester to allow slider to swing free of test surface. Tighten locking knob firmly. Place pendulum in release position and rotate the drag pointer counter clockwise until it comes to rest against adjustment screw on pendulum arm. Release pendulum and note pointer reading. If reading is not zero, loosen locking ring and rotate friction ring on bearing spindle slightly and lock again. Repeat test and adjust friction ring until the pendulum swing carries pointer to zero.

7.3 Slide Length Adjustment:

7.3.1 With pendulum hanging free, place spacer under adjusting screw of lifting handle. Lower pendulum so edge of slider just touches surface. Lock pendulum head firmly, raise lifting handle, and remove spacer.

7.3.2 Raise slider by lifting handle, move pendulum to right lower slider, and allow pendulum to move slowly to left until edge of slider touches surface. Place gage beside slider and parallel to direction of swing to verify length of contact path. Raise slider, using lifting handle, and move pendulum to left, then slowly lower until slider edge again comes to rest on surface. If the length of the contact path is not between 124 and 127 mm (4 7/8 and 5.0 in.) on flat test specimens or between 75 and 78 mm (2 15/16 and 3 1/16 in.) on curved polishing-wheel specimens, measured from trailing edge to trailing edge of the rubber slide, adjust by raising or lowering instrument with the front leveling screws. Readjust level of instrument if necessary. Place pendulum in release position and rotate the drag pointer counter-clockwise until it comes to rest against adjustment screw on pendulum arm.

8. Procedure

8.1 Apply sufficient water to cover the test area thoroughly. Execute one swing, but do not record reading.

NOTE 2—Always catch the pendulum during the early portion of its return swing. While returning the pendulum to its starting position, raise the slider with its lifting handle to prevent contact between the slider and the test surface. Prior to each swing, the pointer should be returned until it rests against the adjustment screw.

8.2 Without delay, make four more swings, rewetting the test area each time and record the results.

NOTE 3—Care should be taken that the slider remains parallel to the test surface during the swings, and does not rotate so that one end rather than the entire striking edge makes the initial contact. Available data indicate that tilting of the slider may cause erroneous BPN readings.

Installation of a small flat spring will relieve the problem. The spring can be inserted into a slot in the spring clip and the assembly secured by the cotter pin as shown in Fig. 4. The free ends of the spring can rest on the slider backing plate to restrain the slider from tilting.

8.3 Recheck the slide contact length in accordance with 4.3.

9. Report

- 9.1 Report the following information:
  - 9.1.1 Individual values in BPN or polish value units,
  - 9.1.2 Temperature of the test surface,
  - 9.1.3 Type, age, condition, texture and location of test surface,
  - 9.1.4 Type and source of aggregate for polish value tests, and
  - 9.1.5 Type and age of the rubber slider.

10. Precision and Bias

NOTE 4—The following material pertains only to the precision and bias of BPN units.

10.1 Repeated tests show standard deviations as follows:

British rubber sliders	1.0 BPN unit
Rubber sliders (conforming to Specification E501)	1.2 BPN units

In both cases the upper quartile of variability is represented in prevailing test instruments. As there is no marked correlation

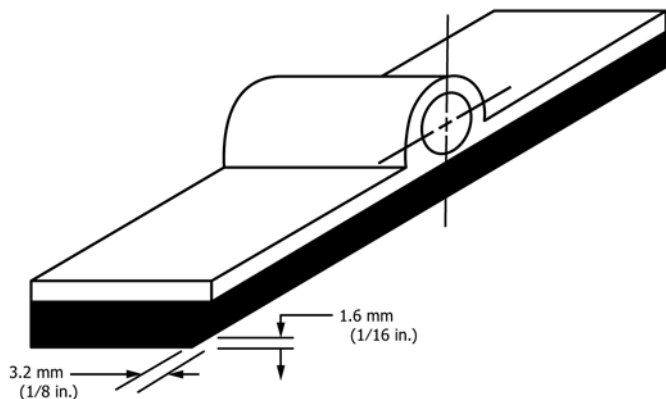

FIG. 3 Slider Assembly Illustrating the Maximum Wear on Striking Edge

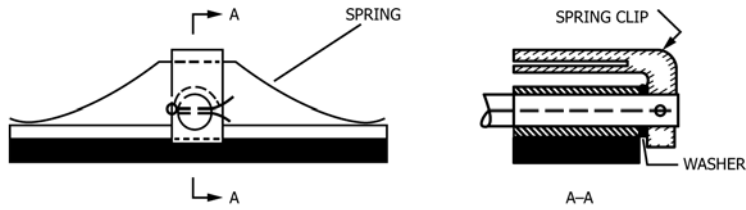

FIG. 4 Spring Clip and Spring to Inhibit Slider Rotation

between standard deviation and arithmetic mean of sets of test values, it appears that standard deviations are pertinent to this test regardless of the average skid resistance being tested.

10.2 The relationship, if any exists, of observed BPN units to some “true” value of skid resistance has not and probably cannot be studied. As a result, precision and bias of this test in relation to a true skid resistance measure cannot be evaluated, and only repeatability is given for the method.

10.3 Determine the testing error as follows:

$$E = t\sigma n^{-1/2} \quad (1)$$

where:

- $E$  = testing error,
- $t$  = normal curve of 1.96 or 2.0 rounded,
- $\sigma$  = standard deviation of individual test results (BPN units), and
- $n$  = number of tests.

10.4 In order to ensure that the testing error stays within 1.0 BPN unit at a 95 % confidence level (corresponding to a normal curve of 1.96 or 2.0 rounded), the following sample sizes are needed:

British natural rubber sliders	4
Synthetic rubber sliders (conforming to Specification E501)	5

## ANNEX

### (Mandatory Information)

#### A1. CALIBRATION

A1.1 *Weight of Pendulum*—The pendulum arm with mounted rubber slider shall be disconnected from the instrument and weighed to the nearest 1 g.

A1.2 *Center of Gravity*—The center of gravity of the pendulum with a mounted rubber slider shall be determined by placing the pendulum assembly over a knife edge and experimentally locating the point of balance as shown in Fig. A1.1. The adaptor nut shall be held at the far end of the arm by a light paper wedge. After the point of balance has been obtained, the position of the balance weight shall be adjusted until the slides of the pendulum foot are horizontal.

A1.3 *Distance of Center of Gravity from Center of Oscillation*—With the pendulum reconnected to the tester and knurled bearing cap removed, distance shall be measured from the center of oscillation (center of bearing nut) to the point of balance (center of gravity). This distance shall be measured directly to the nearest 1 mm (0.04 in.).

A1.4 *Slider Load* —The pendulum shall be clamped to a holder attached to the scale plate of the tester and the tester placed and leveled on a tripod stand as shown in Fig. A1.2. Insert the spacer. Adjust the pan balance with a bearing assembly (see Note A1.1) on one pan and tare weights on the

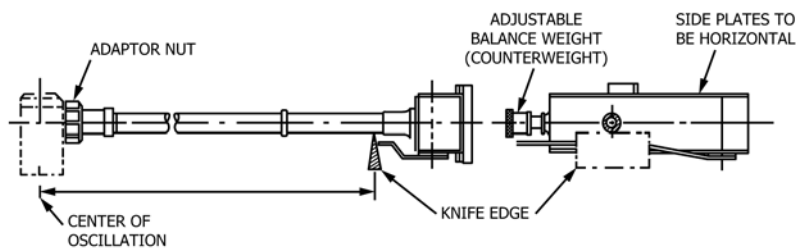

FIG. A1.1 Pendulum Assembly Showing Location of the Point of Balance



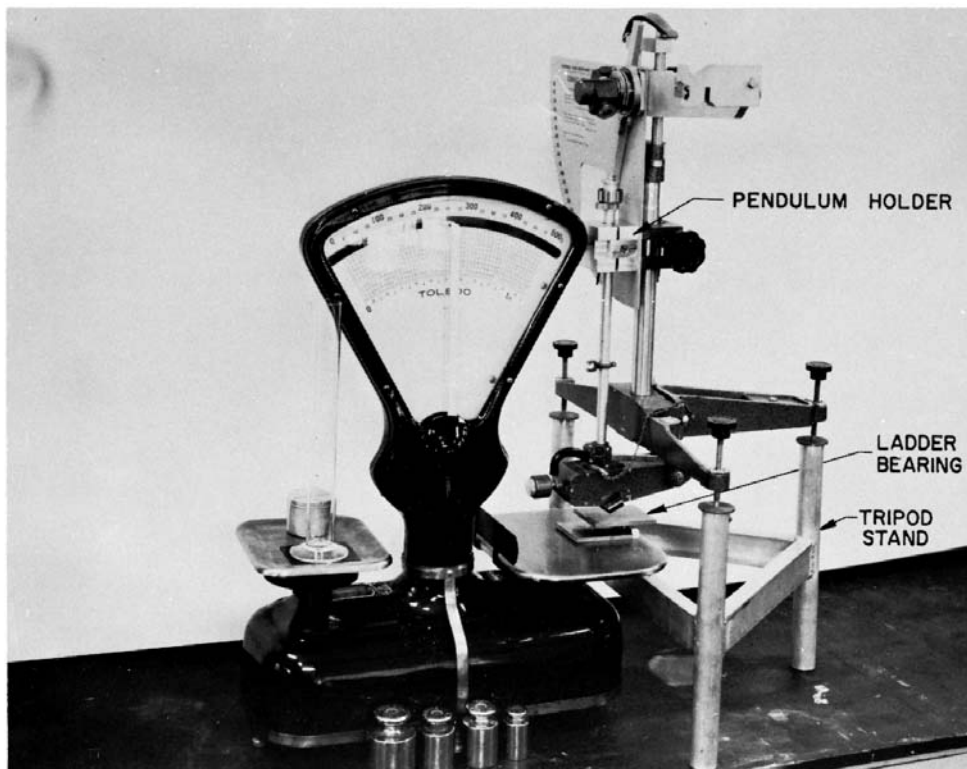

FIG. A1.2 Arrangement of the British Pendulum Tester, Showing Pendulum Assembly and Pan Balance Used to Measure Slider Load

other pan so that the balance pointer is at center scale reading. The pendulum, with a slider, shall be lowered with the vertical height knobs of the tester until the slider is approximately 0.25 mm (0.01 in.) from the top surface of the bearing assembly. Lock vertical height knob and remove the spacer. This will cause an unbalance which shall be partially compensated by adding weights to the opposite pan to bring the indicator to within approximately 200 g of the center scale reading. To complete the balance procedure, the pointer is returned to the center scale reading, by adding water slowly into a graduated cylinder. Empty the cylinder and repeat pouring. Record the average weight required to raise slider so that the balance pointer is at the center of scale (see Note A1.2). If the average,

normal slider load between the 76-mm (3-in.) wide slider and the pan balance is not within the requirements stated in 2.1.1 adjust the spring tension nut illustrated in Fig. 2 and redetermine the slider load.

NOTE A1.1—The bearing assembly may be a “ladder” bearing with a rigid, free-moving top plate or a similar arrangement so that no horizontal loads are introduced while measuring the vertical slider load.

NOTE A1.2—It may be necessary to move the pans of the balance up and down to “work” the spring in order to get smooth and consistent readings. If the measurements of the slider load are still irregular after “working” the spring, remove the side and bottom panels of the pendulum foot and inspect for cleanliness of the bearing surfaces and knife edges illustrated in Fig. 2 and redetermine the slider load.

*ASTM International takes no position respecting the validity of any patent rights asserted in connection with any item mentioned in this standard. Users of this standard are expressly advised that determination of the validity of any such patent rights, and the risk of infringement of such rights, are entirely their own responsibility.*

*This standard is subject to revision at any time by the responsible technical committee and must be reviewed every five years and if not revised, either reapproved or withdrawn. Your comments are invited either for revision of this standard or for additional standards and should be addressed to ASTM International Headquarters. Your comments will receive careful consideration at a meeting of the responsible technical committee, which you may attend. If you feel that your comments have not received a fair hearing you should make your views known to the ASTM Committee on Standards, at the address shown below.*

*This standard is copyrighted by ASTM International, 100 Barr Harbor Drive, PO Box C700, West Conshohocken, PA 19428-2959, United States. Individual reprints (single or multiple copies) of this standard may be obtained by contacting ASTM at the above address or at 610-832-9585 (phone), 610-832-9555 (fax), or service@astm.org (e-mail); or through the ASTM website (www.astm.org). Permission rights to photocopy the standard may also be secured from the Copyright Clearance Center, 222 Rosewood Drive, Danvers, MA 01923, Tel: (978) 646-2600; http://www.copyright.com/*