



Standard Practice for Magnetic Particle Testing for General Industry¹

This standard is issued under the fixed designation E3024/E3024M; the number immediately following the designation indicates the year of original adoption or, in the case of revision, the year of last revision. A number in parentheses indicates the year of last approval. A superscript epsilon (ϵ) indicates an editorial change since the last revision or reapproval.

1. Scope

1.1 This practice establishes minimum requirements for magnetic particle testing used for the detection of surface or slightly subsurface discontinuities in ferromagnetic material. This standard is intended for industrial applications. Refer to Practice [E1444/E1444M](#) for aerospace applications. Guide [E709](#) may be used in conjunction with this practice as a tutorial.

1.2 The magnetic particle testing method is used to detect cracks, laps, seams, inclusions, and other discontinuities on or near the surface of ferromagnetic materials. Magnetic particle testing may be applied to raw material, billets, finished and semi-finished materials, welds, and in-service parts. Magnetic particle testing is not applicable to non-ferromagnetic metals and alloys such as austenitic stainless steels. See [Appendix X1](#) for additional information.

1.3 The values stated in either SI units or inch-pound units are to be regarded separately as standard. The values stated in each system may not be exact equivalents; therefore, each system shall be used independently of the other. Combining values from the two systems may result in non-conformance with the standard.

1.3.1 This standard is a combined standard, an ASTM standard in which rationalized SI units and inch-pound units are included in the same standard, with each system of units to be regarded separately as standard.

1.4 *This standard does not purport to address all of the safety concerns, if any, associated with its use. It is the responsibility of the user of this standard to establish appropriate safety and health practices and determine the applicability of regulatory limitations prior to use.*

2. Referenced Documents

2.1 The following documents form a part of this standard practice to the extent specified herein.

¹ This test method is under the jurisdiction of ASTM Committee [E07](#) on Nondestructive Testing and is the direct responsibility of Subcommittee [E07.03](#) on Liquid Penetrant and Magnetic Particle Methods.

Current edition approved July 1, 2016. Published August, 2016. DOI: 10.1520/E3024_E3024M-16.

2.2 ASTM Standards:²

[E543](#) Specification for Agencies Performing Nondestructive Testing

[E709](#) Guide for Magnetic Particle Testing

[E1316](#) Terminology for Nondestructive Examinations

[E1444/E1444M](#) Practice for Magnetic Particle Testing

[E2297](#) Guide for Use of UV-A and Visible Light Sources and Meters used in the Liquid Penetrant and Magnetic Particle Methods

[E3022](#) Practice for Measurement of Emission Characteristics and Requirements for LED UV-A Lamps Used in Fluorescent Penetrant and Magnetic Particle Testing

2.3 ASNT Documents:³

[SNT-TC-1A](#) Recommended Practice for Personnel Qualification and Certification in Nondestructive Testing

[ANSI/ASNT CP-189](#) Standard for Qualification and Certification of Nondestructive Testing Personnel

2.4 Society of Automotive Engineers (SAE)-AMS Documents:^{4,5}

[AMS 2641](#) Magnetic Particle Inspection Vehicle

[AMS 3040](#) Magnetic Particles, Nonfluorescent, Dry Method

[AMS 3041](#) Magnetic Particles, Nonfluorescent, Wet Method, Oil Vehicle, Ready-To-Use

[AMS 3042](#) Magnetic Particles, Nonfluorescent, Wet Method, Dry Powder

[AMS 3043](#) Magnetic Particles, Nonfluorescent, Wet Method, Oil Vehicle, Aerosol Packaged

[AMS 3044](#) Magnetic Particles, Fluorescent, Wet Method, Dry Powder

[AMS 3045](#) Magnetic Particles, Fluorescent, Wet Method, Oil Vehicle, Ready-To-Use

² For referenced ASTM standards, visit the ASTM website, www.astm.org, or contact ASTM Customer Service at service@astm.org. For *Annual Book of ASTM Standards* volume information, refer to the standard's Document Summary page on the ASTM website.

³ Available from American Society for Nondestructive Testing (ASNT), P.O. Box 28518, 1711 Arlingate Ln., Columbus, OH 43228-0518, <http://www.asnt.org>.

⁴ Available from SAE International (SAE), 400 Commonwealth Dr., Warrendale, PA 15096, <http://www.sae.org>.

⁵ Copies of standards, specifications, drawings, and publications required by manufacturers in connection with specification acquisition should be obtained from the contracting activity or as directed by the contracting officer.

AMS 3046 Magnetic Particles, Fluorescent, Wet Method, Oil Vehicle, Aerosol Packaged

AMS 5062 Steel, Low Carbon Bars, Forgings, Tubing, Sheet, Strip, and Plate 0.25 Carbon, Maximum

AMS I-83387 Inspection Process, Magnetic Rubber

AS 4792 Water Conditioning Agents for Aqueous Magnetic Particle Inspection

AS 5371 Reference Standards Notched Shims for Magnetic Particle Inspection

2.5 Federal Standards:^{5,6}

FED-STD-313 Material Safety Data Sheets, Preparation and the Submission of

2.6 Military Standards:^{5,7}

A-A-59230 Fluid, Magnetic Particle Inspection, Suspension

2.7 OSHA Document:^{5,8}

29 CFR 1910.1200 Hazard Communication

2.8 ISO Documents:^{5,9}

ISO 9712 Nondestructive Testing—Qualification and Certification of NDT Personnel

ISO 10012 Measurement Management Systems—Requirements for Measurement Processes and Measuring Equipment

ISO 17025 General Requirements for the Competence of Testing and Calibration Laboratories

2.9 ANSI Documents:^{5,10}

ANSI Z540.3 Requirements for the Calibration of Measuring and Test Equipment

2.10 Order of Precedence—In the event of conflict between the text of this practice and the referenced documents cited herein, the text of this practice takes precedence.

3. Terminology

3.1 Definitions—The definitions relating to magnetic particle testing, which appear in Terminology for Nondestructive Test Examination E1316, shall apply to the terms used in this practice.

3.2 Definitions of Terms Specific to This Standard:

3.2.1 magnetometer, *n*—mechanical instrument used to measure magnetic field strength, in air, adjacent to the part.

4. Significance and Use

4.1 Description of Process—Magnetic particle testing consists of magnetizing the area to be examined, applying suitably prepared magnetic particles while the area is magnetized, and subsequently interpreting and evaluating any resulting particle

⁶ Available from U.S. Government Printing Office Superintendent of Documents, 732 N. Capitol St., NW, Mail Stop: SDE, Washington, DC 20401, <http://www.access.gpo.gov>.

⁷ Available from Standardization Documents Order Desk, DODSSP, Bldg. 4, Section D, 700 Robbins Ave., Philadelphia, PA 19111-5098, <http://dodssp.daps.dla.mil>.

⁸ Available from U.S. Government Printing Office Superintendent of Documents, 732 N. Capitol St., NW, Mail Stop: SDE, Washington, DC 20401, <http://www.access.gpo.gov>.

⁹ Available from International Organization for Standardization (ISO), ISO Central Secretariat, BIBC II, Chemin de Blandonnet 8, CP 401, 1214 Vernier, Geneva, Switzerland, <http://www.iso.org>.

¹⁰ Available from American National Standards Institute (ANSI), 25 W. 43rd St., 4th Floor, New York, NY 10036, <http://www.ansi.org>.

accumulations. Maximum detectability occurs when the discontinuity is positioned on the surface and perpendicular to the direction of magnetic flux in the part.

4.2 This practice establishes the basic parameters for controlling the application of the magnetic particle testing method. This practice is written so that it can be specified on the engineering drawing, specification, or contract. It is not a detailed how-to procedure to be used by the examination personnel and, therefore, must be supplemented by a detailed written procedure that conforms to the requirements of this practice.

5. General Practice

5.1 Personnel Qualification—Personnel performing examinations in accordance with this practice shall be qualified and certified in accordance with ASNT Recommended Practice No. SNT-TC-1A, ANSI/ASNT Standard CP-189, ISO 9712, or as specified in the contract or purchase order.

5.2 Agency Qualification—If specified in the contractual agreement, NDT agencies shall be qualified and evaluated as described in Specification E543. The applicable edition of Specification E543 shall be specified in the contractual agreement.

5.3 Written Procedure—Magnetic particle testing shall be performed in accordance with a written procedure applicable to the part or group of parts under examination. The procedure shall be in accordance with the requirements of this practice. The process, when conducted in accordance with the written procedure, shall be capable of detecting discontinuities specified in the acceptance criteria. The written procedure may be general if it clearly applies to all of the specified parts being examined and meets the requirements of this practice. All written procedures, including technique sheets for specific parts, shall be approved by an individual qualified and certified at Level III for magnetic particle testing in accordance with the requirements of subsection 5.1.

5.3.1 Elements of the Written Procedure—The written procedure shall include at least the following elements, either directly or by reference to the applicable documents:

5.3.1.1 Procedure identification number and the date it was written;

5.3.1.2 Identification of the part(s) to which the procedure applies; this shall include the material or alloy, or both;

5.3.1.3 For new components, sequence of magnetic particle testing as related to manufacturing process operation (for example, post-plating, after heat treat, etc.);

5.3.1.4 Identification of test parts used for system performance verification (see 7.1.1 and 7.1.2);

5.3.1.5 Process controls (see Table 1); including the definition of “use” in subsections 7.3.2.2 and 7.4.4;

5.3.1.6 Areas of the part to be examined and where appropriate, identified by a photograph, sketch, or relationship to a drawing, etc., to show the area;

5.3.1.7 Part preparation required before examination;

5.3.1.8 Directions for positioning the item with respect to the magnetizing equipment;

TABLE 1 Required Verification Intervals

Item	Maximum Time Between Verification ^A	Paragraph
Lighting		
Visible light intensity	Weekly	7.3.1.1, 7.3.1.2
Ambient visible light intensity	Weekly	7.3.1.2
UV-A intensity	Daily	7.3.2, 7.4.5
Battery powered UV-A lamp intensity	Before and after each use	7.3.2.2
UV-A lamp integrity	Weekly	7.3.2
System Performance ^B	Daily	7.1.7.1.1, 7.1.2
Wet particle concentration	8 hours, or every shift change	7.2.1.1
Wet particle contamination ^B	1 week	7.2.1.2
Water break test	Daily	7.2.2
Equipment calibration check: ^B		
Timer control	6 months	7.4.1
Quick break	6 months	7.4.2
Yoke dead weight check	6 months	7.4.3
Yoke dead weight check (battery-powered)	6 months	7.4.4
UV-A radiometers and visible light meters	Before and after each use	7.4.4
Electronic Gaussmeter accuracy	12 months	7.4.7
Magnetometer accuracy	12 months	7.4.6
Magnetometer accuracy	6 months	7.4.6

^AWhen the test system is in operation.

^BThe maximum time between verifications may be reduced or extended when substantiated by actual technical/reliability data.

5.3.1.9 The type of magnetizing current and the equipment to be used;

5.3.1.10 Method of establishing the magnetization (internal conductor, head, coil, prods, yoke, cable wrap, etc.);

5.3.1.11 Directions of magnetization to be used, the order in which they are applied, and any demagnetization procedures to be used between field applications;

5.3.1.12 The current level, or the number of ampere turns, to be used and the duration of its application or a procedure for establishing proper magnetization;

5.3.1.13 Type of magnetic particle material (dry or wet, visible or fluorescent, etc.) to be used and the method and equipment to be used for its application and, for the case of wet particles, the particle concentration limits;

5.3.1.14 Type of records and method of marking parts after examination;

5.3.1.15 Acceptance requirements, to be used for evaluating indications and disposition of parts after evaluation; and

5.3.1.16 Post-examination demagnetization and cleaning requirements.

5.4 *Examination Sequence*—Perform magnetic particle examination after all operations which might cause or reveal discontinuities. Such operations include, but are not limited to, forging, heat treating, electroplating, forming, welding, grinding, straightening, machining, and proof loading.

5.4.1 Unless otherwise specified in the contract or part drawing, magnetic particle examination shall be performed prior to shot peening and prior to applying protective finishes such as priming, painting, plating (see 5.4.3 through 5.4.3.2), or other coatings.

5.4.2 In-process examinations may not be substituted for final examination.

5.4.3 *Plating and Coatings*—The written procedure shall specify any limitations or other requirements associated with plating or coatings.

5.4.3.1 Use caution when examining parts with an electroplated nickel coating as indications may form from the resulting leakage fields within the nickel plating itself.

5.4.3.2 For in-service examination, plating or coatings do not require removal prior to examination unless they are damaged or they interfere with the examination process.

NOTE 1—Examination sensitivity decreases as plating/coating thickness increases.

5.5 *Materials:*

5.5.1 *Dry Particle Requirements*—Dry particles shall meet the requirements of AMS 3040.

5.5.2 *Wet Particle Requirements*—Wet particles shall meet the requirements of AMS 3041, 3042, 3043, 3044, 3045, or 3046, as applicable.

5.5.3 *Suspension Vehicles*—The suspension vehicle for the wet method shall be a light petroleum distillate conforming to AMS 2641 (Type I) or A-A-59230, or a suitably conditioned water that conforms to the requirements of 5.5.4. When approved by the Level III, AMS 2641 (Type II) may be used. When specified, the oil suspension vehicle shall meet the salient characteristics specified in A-A-59230.

5.5.4 *Conditioned Water Vehicle*—When water is used as a suspension vehicle for magnetic particles, the conditioning agents used shall comply with AS 4792. Proper wetting shall be determined by a water break test (see 7.2.2). Smoother surfaces generally require a greater percent of wetting agent than rough surfaces. Foaming of the bath must be minimized to the point that it does not interfere with the examination process.

5.5.4.1 *Water Vehicle Conditioning Agents*—Any agents added to the water vehicle for any purpose shall conform to the requirements of the particle manufacturer.

5.5.5 *Particle Concentration*—The concentration of particles in the suspension bath shall be as specified in the written procedure. Particle concentrations outside of the range of 0.1 to 0.4 mL in a 100-mL bath sample for fluorescent particles and 1.2 to 2.4 mL in a 100 mL sample for nonfluorescent particles shall not be used. Fluorescent particles and nonfluorescent particles shall not be used together.

5.6 *Safety*—The safe handling of magnetic particles (wet or dry), oil vehicles, water baths, and water conditioner concentrates are governed by the suppliers' Safety Data Sheets (SDS). SDS, conforming to 29 CFR 1910.1200, or equivalent, must be provided by the supplier to any user and shall be prepared in accordance with FEDSTD-313.

5.6.1 *Flammability*—Flash point of oil vehicles shall be in accordance with AMS 2641, Type I carriers. The suppliers' SDS shall certify the flash point.

5.6.2 *Personnel Hazards*—Precautions against inhalation, skin contact, and eye exposure are detailed in the suppliers' SDS. These precautions shall be observed.

5.6.3 *Electrical Hazards*—Magnetizing equipment shall be maintained properly to prevent personnel hazards from electrical short circuits. Care must be taken to reduce arcing and the possible ignition of oil baths.

5.6.4 *Ultraviolet (UV-A) Lamp*—Replace cracked or broken ultraviolet filters immediately. Broken filters can allow harmful shortwave ultraviolet energy to be emitted and must be replaced immediately. Spectacles designed to absorb ultraviolet wavelength radiation are suggested for close, high-intensity UV-A lamp examination.

6. Specific Practice

6.1 Preparation of Parts for Testing

6.1.1 *Pre-examination Demagnetization*—The part shall be demagnetized before testing if prior operations have produced a residual magnetic field that may interfere with the examination.

6.1.2 *Surface Cleanliness and Finish*—The surface of the part to be examined shall be essentially smooth, clean, dry, and free of oil, scale, machining marks, or other contaminants or conditions that might interfere with the efficiency of the examination.

6.1.3 *Plugging and Masking*—Plugging and masking is required when specified.

6.1.4 All areas on the part where electrical contact is made shall be sufficiently clean to prevent electrical arcing.

6.2 Magnetization Methods:

6.2.1 *Types of Magnetizing Current*—The types of currents used for magnetic particle testing are full-wave rectified current (1 or 3 phase), half-wave rectified current, alternating current, direct current, and capacitor discharge current. The equipment used shall fulfill the magnetizing and demagnetizing requirements adequately, as outlined herein, without damage to the part under examination, and they shall include the necessary features required for safe operation.

6.2.2 *Permanent Magnets*—Permanent magnets may be used when approved by the Level III and when a technique has been developed and approved.

6.2.3 *Yokes*—When using yokes (electromagnetic probes) for magnetic particle testing, they shall meet the requirements of 7.4.4.

6.2.3.1 When using yokes, the pole pieces shall be positioned in contact with the part surface as flat as possible.

6.2.3.2 Yoke leg positioning shall include overlapping shots with consideration for the banding effects at the leg/pole contact points.

6.2.3.3 When examining localized areas on parts with complicated geometries, leg spacing shall include consideration for both field direction and banding effects.

6.2.3.4 When using portable equipment that is not timer controlled, any examination that does not have the magnetizing power on during both particle application and excess particle removal is considered a residual examination.

6.2.3.5 For weld examinations, one yoke orientation shall be approximately perpendicular to the weld with the second orientation set parallel to the weld.

6.2.3.6 Battery powered DC yokes may be used when approved by the Level III and when a technique has been developed and approved.

(1) The technique must be validated for material thickness greater than $\frac{3}{8}$ in. (9.5 mm).

(2) Battery powered yokes may not show all surface indications for all thicknesses of material, even though the requirements in 7.4.4 have been met and/or the field strength has been indicated on a shim.

NOTE 2—Use of dry magnetic particles for surface indications is not recommended when using battery powered DC yokes.

6.2.4 *Magnetizing Current Application*—Full-wave rectified current has the deepest penetration and should be used for examination of sub-surface discontinuities when using the wet magnetic particle method. Half-wave rectified current may also be used for examination of sub-surface discontinuities and due to the pulsating nature of the waveform; it has the advantage of increased particle mobility. Alternating current is to be only used for the detection of discontinuities open to the surface.

6.2.4.1 *Direct Current (DC)*—Direct Current is produced by banks of batteries, full-wave rectified AC or a DC generator.

6.2.4.2 *Capacitor Discharge (CD) Current*—A bank of capacitors are used to store energy and when triggered the energy reaches high amperage with a very short duration (normally less than 25 milliseconds). Because of the short pulse duration, the current requirements are affected by the amount of material to be magnetized as well as the applied amperage. The capacitor discharge technique may be used to establish a residual magnetic field in tubing, casing, line pipe, and drill pipe. For specific requirements, see [Appendix X5](#).

6.2.5 *Magnetic Field Directions*—Discontinuities are difficult to detect by the magnetic particle method when they make an angle less than 45° to the direction of magnetization. To ensure the detection of discontinuities in any direction, each part must be magnetized in a minimum of two directions at approximately right angles to each other. Depending on part geometry, this may consist of circular magnetization in two or more directions, multiple circular and longitudinal magnetizations, or of longitudinal magnetization in two or more directions. The pie-field indicator as illustrated in Fig. X4.1, the flexible laminated strips as described in [Annex A3](#), or a properly prepared master part using notched shims may only be used as a tool to demonstrate the direction of the external magnetic field. The pie-field indicator or flexible laminated strips shall not be used to determine adequate field strength.

6.2.6 *Multidirectional Magnetization*—Multidirectional magnetization may be used to fulfill the requirement for magnetization in two or more directions if it is demonstrated

that the technique is effective in all areas requiring examination. Test parts in accordance with 6.3.1.1 or shims manufactured to the requirements of AS 5371 shall be used to verify field direction, strength, and balance in multidirectional magnetization. Balancing of the combined magnetic field is critical and an adequate balance must be visually demonstrated to be effective in all areas requiring examination. The particle application must be timed so that the magnetization levels reach full value in all directions while the particles are mobile on the surface under examination.

6.2.7 *Direct Magnetization*—Direct magnetization is accomplished by passing current directly through the part under examination. Electrical contact is made to the part using head and tail stock, prods, clamps, magnetic leeches, or by other means. Caution shall be taken to ensure that the electrical current is not flowing while contacts are being applied or removed and that excessive heating does not occur in any area of the part. Prods shall not be used for the examination of finished surfaces.

6.2.8 *Indirect Magnetization*—Indirect part magnetization uses pre-formed coils, cable wraps, yokes, field (flux) flow fixtures, or an internal conductor to induce a magnetic field in a part when no direct electrical contact is made.

6.2.9 *Induced Current Magnetization*—Induced current magnetization (toroidal or circumferential field) is accomplished by inductively coupling a part to an electrical coil in order to create a suitable current flow within the part as illustrated in Fig. X4.2. This method is often advantageous on ring-shaped parts with a central aperture and with an L/D ratio less than three, especially where the elimination of arcing or burning is of vital importance.

6.2.10 *Parallel Current Induced Magnetization*—This method of magnetization may occur when a ferromagnetic part is placed alongside and parallel to a current-carrying conductor. This type of magnetization shall only be used when approved by the Level III and when an approved technique has been developed for use on solid parts.

6.3 *Magnetic Field Strength:*

6.3.1 *Magnetic Field Strength*—The applied magnetic field shall have sufficient strength to produce satisfactory indications, but it must not be so strong that it causes the masking of relevant indications by nonrelevant accumulations of magnetic particles. Adequate magnetic field strength may be determined by one or a combination of the following methods.

6.3.1.1 In unidirectional or multidirectional magnetizing applications, by examining parts having known or artificial discontinuities of the type, size, and location specified in the acceptance requirements or by using the notched shims as defined in Annex A1.

6.3.1.2 In unidirectional magnetizing applications only, by using an electronic gaussmeter capable of measuring the peak values of the tangential field as described in Annex A4. Tangential-field strengths shall have a minimum value of 30 Gauss (30×10^{-4} Tesla [T]) when measured at the part surface using an electronic gaussmeter as described in Annex A4. The maximum Gauss value derived is limited by the restrictions of 6.3.1.

6.3.1.3 For circular magnetization, the written procedure shall specify the amperage requirements for the specific part to be examined. If the requirements are unknown, the formulas in Appendix X3 may be used as a starting point in developing the required amperage for specific parts.

6.3.1.4 For longitudinal magnetization, the written procedure shall specify the amp-turns, particle mobility characteristics and/or external field strength requirements for the specific part to be examined. If the requirements are unknown, the formulas in Appendix X3 in Guide E709 may be used as a starting point in developing the required amperage for specific parts. The current levels and formulas in Guide E709 provide only a rough guide and shall only be used in conjunction with either 6.3.1.1, or 6.3.1.2. In some cases, these formulas may lead to over magnetization of the work piece and care should be exercised when using them.

6.3.2 *Longitudinal Magnetization Using Coils*—The actual effective distance must be demonstrated based on the particular part to be examined. For parts longer than these effective distances, the entire length shall be examined by repositioning the part within the coil, allowing for approximately 10 % effective magnetic field overlap. See 6.3.1 for field strength methods that can be used in coil magnetization.

6.4 *Particle Application*

6.4.1 *Dry Magnetic Particle Application, Continuous Method*—When using dry particles, the flow of magnetizing current shall be initiated prior to application of the magnetic particles to the surface under examination and terminated after particle application has been completed and any excess blown off. Precautions shall be taken to prevent any damage to the part due to overheating.

6.4.1.1 Apply dry powder so that a light, uniform, dust-like coating settles on the surface of the part under examination while the part is being magnetized. Specially designed powder blowers or shakers using compressed air or hand power shall be used. The applicators shall introduce the particles into the air in a manner such that they reach the part surface in a uniform cloud with a minimum of force.

6.4.1.2 After the powder is applied, and before the magnetizing force is removed, excess powder shall be removed, by means of a dry air current with sufficient force to remove the excess particles, if they interfere with interpretation and evaluation, but not strong enough to disturb particles held by a leakage field that is indicative of discontinuities. In order to recognize the broad, fuzzy, lightly held powder patterns formed by near-surface discontinuities, the formation of indications must be observed carefully during both powder application and removal of the excess powder.

6.4.1.3 Dry magnetic particles shall not be reused, unless a process for reclamation has been established and approved by the Level III.

6.4.2 *Wet Magnetic Particle Application, Continuous Method*—Fluorescent or nonfluorescent particles suspended in a liquid vehicle at the required concentration shall be applied by gently spraying or flowing the suspension over the area to be examined.

6.4.2.1 Proper sequencing and timing of part magnetization and application of particle suspension are required to obtain the

proper formation and retention of indications. This requires that the stream of suspension be diverted from the part simultaneously with, or slightly before, energizing the magnetic circuit.

6.4.2.2 The magnetizing current shall be applied for a duration of at least 0.5 second for each application, with a minimum of two shots being used. The second shot shall follow the first while the particles are still mobile on the surface of the part.

6.4.2.3 Under special circumstances, such as the use of automated equipment or for critical parts, the 0.5-second duration and the two-shot requirement may be waived provided it is demonstrated that the procedure can detect known discontinuities in reference parts.

6.4.2.4 Care shall be exercised to prevent any damage to the part due to overheating or other causes. Weakly held indications on highly finished parts are readily washed away, and care must be exercised to prevent high-velocity flow over critical surfaces.

6.4.2.5 Particle application by continuous immersion shall be used only when it has been documented that it can detect discontinuities or artificial discontinuities in parts under examination.

6.4.3 *Residual Magnetization Method*—In the residual magnetization method, the magnetic particles (dry or wet) are applied to the part under examination after the magnetizing force has been discontinued. The residual method is not as sensitive as the continuous method. It can be useful on materials with high retentivity. When inducing circular fields and longitudinal fields in long pieces, residual fields are normally sufficient to meet magnetizing requirements consistent with the requirements of 7.1.1 or 7.1.2. The residual method has found wide use examining pipe and tubular goods. For magnetization requirements of oilfield tubulars, refer to **Appendix X5**. It is also useful for the examination of parts or areas of parts, which because of geometric constraints, cannot be examined with the continuous method. The residual method shall be used only when it has been documented that it can detect discontinuities or artificial discontinuities in parts under examination and when approved by the Level III. The test parts shall have the same material and processing steps, and similar geometry, to the actual parts being examined.

6.4.4 *Magnetic Slurry/Paint Application*—Magnetic paints or slurries are applied to the part with a brush, squeeze bottle, or aerosol can before or during the magnetization operation. This method is for special applications, such as overhead or underwater examination.

6.4.5 *Magnetic Polymer Application*—Polymerizable material containing magnetic particles shall be held in contact with the part under examination during the period of its cure. Before curing takes place, and while the magnetic particles are still mobile, the part shall be magnetized to the specified level. This requires prolonged or repeated periods of magnetization. This method is for special applications, such as bolt holes which cannot be examined readily by the wet or dry method. AMS-I-83387 establishes the examination process for magnetic rubber.

6.5 *Evaluation*—Following magnetization and particle application, the parts shall be examined for indications. All

indications will be identified as relevant or nonrelevant. Relevant indications will be compared to the proper accept/reject criteria and the parts accepted or rejected accordingly.

6.5.1 *Eye Glasses*—Personnel shall not wear eye glasses that are photochromic or that have permanently darkened lenses. This is not intended to prohibit the use of eyeglasses with lenses treated to absorb UV-A.

6.5.2 *Dark Adaptation*—Personnel must wait at least one minute after entering a darkened area for their eyes to adjust to the low-level lighting before performing fluorescent magnetic particle testing.

6.5.3 *Acceptance Requirements*—The acceptance requirements applicable to the part or group of parts shall be incorporated as part of the written procedure either specifically or by reference to other applicable documents containing the necessary information.

6.6 *Recording of Indications*—When required by the written procedure, the location of all rejectable indications shall be marked on the part, and permanent records of the location, direction, and frequency of indications may be made by one or more of the following methods:

6.6.1 *Written Description*—By recording the location, length, direction, and number of indications in sketch or tabular form;

6.6.2 *Transparent Tape*—For dry particle indications, by applying transparent adhesive-backed tape to which the indications will adhere and placing it on an approved form along with information giving its location on the part;

6.6.3 *Strippable Film*—By covering the indication with a spray-on strippable film that fixes the indications in place and placing the resultant reproduction on an approved form along with information giving its location on the part; and

6.6.4 *Photography*—By photographing or video recording the indications themselves, the tape, or the strippable film reproduction and placing the photograph in a tabular form along with information giving its location on the part.

6.7 *Post-Examination Demagnetization and Cleaning*—All parts shall be demagnetized and cleaned after final examination. Apply corrosion protection as required.

6.7.1 *Demagnetization:*

6.7.1.1 When using AC demagnetization, the part shall be subjected to a field with a peak value greater than, and in nearly the same direction as, the field used during examination. This AC field is then decreased gradually to zero. When using an AC demagnetizing coil, the part is passed through the coil while the current is flowing. For effective demagnetization, parts having complex configurations may require rotating or tumbling while passing through the field of the coil prior to the current being shut off. Repeat this process as necessary.

6.7.1.2 When using DC demagnetization, the initial field shall be higher than, and in nearly the same direction as, the field reached during examination. The field shall then be reversed, decreased in magnitude, and the process repeated (cycled) until an acceptably low value of residual field is reached.

6.7.1.3 Whenever possible, parts that have been magnetized circularly shall be magnetized in the longitudinal direction before being demagnetized. After demagnetization, a calibrated

magnetometer shall not exceed a value agreed upon or as specified on the engineering drawing or in the contract, purchase order, or specification. If an electronic gaussmeter is used for this measurement, the equivalency shall be determined prior to use.

6.7.2 *Post-Examination Cleaning*—Cleaning shall be done with a suitable solvent, air blower, or by other means.

6.7.2.1 Parts shall be examined to ensure that the cleaning procedure has removed magnetic particle residues from all surfaces, including holes, crevices, passage ways, etc. Such residue could have an adverse effect on the intended use of the part.

6.7.2.2 Care shall be taken to remove all plugs, masking, or other processing aids that may affect the intended use of the part.

6.7.2.3 Parts shall be protected from corrosion or damage as required.

6.8 *Record of Examination*—Results of all final magnetic particle examinations shall be recorded. All recorded results shall be identified and filed. Records shall provide for traceability to the specific part or lot examined. As a minimum, the records shall include: identification of the procedure used, disposition of the examination; identification of the inspector's examination stamp, electronic ID or signature; and the date of examination. Records shall be kept for the duration specified in the purchase order or contract.

6.9 *Marking of Accepted Parts*—Parts that have been accepted using magnetic particle testing shall be marked in accordance with the applicable drawing, purchase order, contract prior to leaving the testing facility.

7. Quality Control

7.1 *System Performance Verification*—The overall performance of the magnetic particle testing system, including the equipment, materials, and the lighting environment being used, shall be verified initially and at regular intervals thereafter. The required verification intervals are stated in **Table 1**. Records of the verification results shall be maintained and retained for the time period specified in the contract. Establish a system in accordance with ISO 17025 or ISO 10012 for calibration and certification of all current and voltage measuring devices, ammeter shunts, timers, lightmeters, electronic gaussmeters, and magnetometers used in verification.

7.1.1 *Use of Test Parts with Discontinuities*—A reliable method for system performance verification is the use of representative reference parts containing discontinuities of the type, location, and size specified in the acceptance requirements and examined in accordance with a written procedure. If correct magnetic particle indications can be produced and identified in these representative parts, the overall system performance is verified. Parts used for verification will be demagnetized, cleaned thoroughly following the examination, and checked under UV-A or visible light, as appropriate to the examination process, to ensure that residual indications do not remain.

7.1.2 *Fabricated Test Parts with Artificial Discontinuities*—When actual production parts with known discontinuities of the type, location, and size needed for verification are not available

or are impractical, fabricated test or production parts with artificial discontinuities or a ring specimen (see Guide **E709**, Appendix X7) may be used. Artificial discontinuities may be fabricated to meet a particular need or may be commercially available shims as shown in **Annex A2**. All applicable conditions for the use of such reference parts, as described in **7.1.1**, shall apply.

7.2 *Suspension Vehicle Tests (Not required for aerosol can suspensions)*

7.2.1 *Concentration/Contamination Tests*—Particle concentration and contamination shall be determined upon start up, at regular intervals thereafter, and whenever the bath is changed or adjusted. The required testing intervals are stated in **Table 1**.

7.2.1.1 *Determination of Wet Particle Concentration*—For recirculation systems, agitate the particle suspension a minimum of 30 min to ensure uniform distribution of particles throughout the bath. For portable application devices, agitate the particle suspension for a sufficient period of time to ensure uniform distribution of particles throughout the bath. Place a 100-mL sample of the agitated suspension in a pear-shaped centrifuge tube with a graduated stem in 0.05-mL increments for fluorescent baths and 0.1 mL for non-fluorescent baths. (Centrifuge tubes shall be as specified in Guide **E709**). Demagnetize the sample and allow the tube to stand undisturbed for a settling time of at least 60 min if using petroleum distillate or at least 30 min for conditioned water suspension. Read the volume of settled particles. If the concentration is out of the tolerance stated in the written procedure add particles or suspension vehicle, as required, and re-determine the particle concentration. If the settled particles appear to be loose agglomerates rather than a solid layer, repeat the process with a second sample. If the second sample also appears agglomerated, replace the entire bath suspension. 30 min settling times (for petroleum distillate suspensions), or other accelerated tests, may be used if they have been verified to give results equivalent to the procedure described in this clause.

7.2.1.2 *Determination of Wet Particle Contamination for Recirculation Systems*—Perform the tests specified in **7.2.1.1**. Examine the graduated portion of the tube, under both UV-A (for fluorescent baths only) and visible light (for both fluorescent and nonfluorescent baths), for striations or bands, different in color or appearance. Bands or striations may indicate contamination. If the total volume of the contaminants, including bands or striations, exceeds 30 % of the volume of magnetic particles the bath must be adjusted or replaced.

7.2.2 *Water Break Test*—In this test of water-based vehicles, a clean part with a surface finish the same as the parts to be examined or an actual production part is flooded with the conditioned water, and the appearance of the surface is noted after flooding is stopped. Sufficient wetting agent is present if a continuous even film forms over the entire part. If the film of suspension breaks, exposing bare surface, insufficient wetting agent is present or the part has not been cleaned adequately. For adequacy, this visual observation shall be performed individually under both UV-A and/or visible light conditions as applicable.

7.2.3 *Determination of Particle Sensitivity*—**Appendix X2** describes several devices that can demonstrate the sensitivity

of either wet-method or dry-method particles. These devices contain permanent magnetization in some form and are independent of the magnetizing system. They should not be magnetized or demagnetized before or after use. Such devices can be useful whenever performance of the particles are subject to question or need to be verified.

7.3 Lighting:

7.3.1 *Visible Light*—Conduct visible light intensity measurements upon initial light installation, or when changes occur that would cause the light intensity to change and at the intervals specified in [Table 1](#).

7.3.1.1 Visible light shall be used when examining with nonfluorescent magnetic particles and for interpretation of indications found with fluorescent magnetic particles. A minimum light intensity of 100 fc [1076 lx] shall be available at the surface of the part undergoing examination or evaluation.

7.3.1.2 *Ambient Visible Light*—Fluorescent magnetic particle examinations shall be performed in a darkened area with a maximum ambient visible light level of 2 fc [22 lx] measured at the part surface.

7.3.2 *UV-A Lamps*—UV-A lamps used for evaluation purposes shall meet the requirements of [7.4.5](#). The minimum acceptable intensity is 1000 $\mu\text{W}/\text{cm}^2$ at the surface being examined. UV-A lamps shall be checked for cleanliness and integrity and shall be cleaned, repaired or replaced as appropriate. These checks of cleanliness/integrity need not be recorded.

7.3.2.1 UV-A lamps that use an LED source shall produce a peak wavelength at 360 to 370 nanometers as measured with a spectroradiometer. When requested, the manufacturer shall provide a certification thereof.

7.3.2.2 Battery-powered UV-A lamps used to examine parts shall have their intensity measured prior to use and after each use. Intensity shall be measured before the lamp is turned off after use. If the lamp is equipped with automatic current sensing circuitry that shuts off the lamp prior to falling below the minimum intensity, the after use check is not required.

7.3.2.3 UV-A irradiation from LED sources will typically decrease as the lamp warms up. Warm-up time as listed by the manufacturer shall be considered when measuring UV intensity.

NOTE 3—More information on UV-A sources, visible lights, radiometers and light meters can be found in [Guide E2297](#) and [E3022](#).

7.3.3 *Restricted Area Examination*—Where lamps are physically too large to directly illuminate the examination surface, special lighting, such as UV-A pencil lamps, or UV-A guides, or borescopes shall be used. The image viewed must have sufficient resolution to effectively evaluate the required discontinuities. Light intensity shall be measured at the expected working distance and shall meet the requirements of [7.3.2](#) as appropriate.

7.4 *Equipment Calibration*—Magnetic particle testing equipment shall be checked for performance and accuracy at the time of purchase, at the intervals indicated in [Table 1](#), when a malfunction is suspected, or when electrical maintenance that might affect equipment accuracy is performed.

7.4.1 *Ammeter Accuracy*—To check the equipment ammeter, a suitable calibrated shunt test kit shall be connected in series with the output circuit. Comparative readings shall be taken at three output levels encompassing the usable range of the equipment. The equipment meter reading shall not deviate by more than $\pm 10\%$ or 50 amperes, whichever is greater, from the current value shown by the calibrated ammeter. (When measuring half-wave rectified current, the current values shown by the calibrated FW-Rectified ammeter readings shall be doubled.) The frequency of the ammeter check is specified in [Table 1](#). Machine output repeatability shall not vary more than $\pm 10\%$ or 50 amperes, whichever is greater, at any setpoint and the machine under test shall be marked with the value representing the lowest repeatable current level.

7.4.2 *Timer Control Check*—On equipment using a timer to control the current duration, the timer should be calibrated to within ± 0.1 s using a suitable electronic timer.

7.4.3 *Magnetic Field Quick Break Check*—On equipment that uses a quick break feature, proper functioning of this circuit shall be verified. The check may be performed using a suitable oscilloscope or other applicable method as specified by the equipment manufacturer.

7.4.4 *Dead Weight Check*—Yokes shall be dead weight checked at intervals as stated in [Table 1](#). Alternating current yokes shall have a lifting force of at least 10 lb [4.5 kg], with a 2- to 6-in. [50- to 150-mm] spacing between legs. Direct current yokes shall have a lifting force of at least 30 lb [13.5 kg], with a 2- to 4-in. [50- to 100-mm] spacing between legs, or 50 lb [22.5 kg], with a 4- to 6-in. [100- to 150-mm] spacing. For battery powered yokes, the check shall be performed prior to and after each use.

7.4.5 *UV-A Lamps*—UV-A lamps, which are portable, hand-held, permanently mounted or fixed, and used to examine parts, shall be checked for output at the frequency specified in [Table 1](#) and after bulb replacement. A longer period may be used if a plan justifying this extension is prepared by the NDT facility or its delegate. Minimum acceptable intensity is 1000 $\mu\text{W}/\text{cm}^2$ at 15 in. [38.1 cm] from the front of the filter to the face of the sensor. Damaged or dirty filters shall be replaced or otherwise corrected as appropriate. LED UV lamps used for evaluation purposes shall comply with [Practice E3022](#).

NOTE 4—Some UV-A sources other than mercury vapor, for example, micro-discharge, LED, etc., have been shown to have emission characteristics such as excessive visible light, and UV-A intensity that may result in fluorescent fade, veiling glare, etc., all of which can significantly degrade examination reliability.

7.4.6 *Electronic Gaussmeters and Magnetometers* shall be calibrated and a reading taken at a minimum of three points in each dynamic range and each polarity, in addition to zero.

7.4.7 *UV-A Radiometers and Visible Light Meters*—All meters shall be calibrated in accordance with manufacturers recommended procedures and shall be traceable to the National Institute of Standards and Technology (NIST) or other recognized national standards, where applicable.

8. Keywords

8.1 dye; fluorescent; FP; FPI; magnetic particle; MPI; MT; nondestructive evaluation; nondestructive examination; nondestructive testing; NDT

ANNEXES

(Mandatory Information)

A1. INSTRUCTIONS FOR THE USE OF AS 5371 STANDARD NOTCHED SHIMS

A1.1 **Application of Shims**—The Reference Standard Notched Shims of AS 5371, as shown in [Annex A2](#), require specific handling, attachment, and care for accurate indication of magnetic field strength and direction. To select amperage settings for multi-directional magnetization, the use of AS 5371 shims or parts described in [6.3.1.1](#) is mandatory.

A1.2 Shims 0.002 in. [0.05 mm] thick shall be used on curved or complex surfaces.

A1.3 Shims are manufactured of low carbon steel and must be protected from corrosion when not in use. They may be submerged in a solvent such as MEK or naphtha for storage. Before attaching the shim to the part, both the shim and part shall be clean and dry.

NOTE A1.1—Polar solvents, such as water, will not break down the cyanoacrylate-based adhesives (super glue) commonly used to apply these shims.

A1.4 The shim shall be placed in intimate contact with the part with the flaw side next to the material to be examined.

A1.5 The shim shall be securely fastened to the part by using an adhesive or tape (such as Scotch Brand 191, 471, or 600 series) that prevents the magnetic particle suspension from entering between the shim and part. Whatever means is used to secure the shim to the part shall not interfere with the visibility of the indications.

A1.6 Tape may be used to secure the shim and shall have the following properties: (1) Good adhesion to steel, (2) Impervious to the suspension used, and (3) the tape shall be non-fluorescent under UV-A (for fluorescent suspensions).

A1.7 If the tape becomes loose, allowing the suspension to seep under the shim, the tape and shim shall be carefully removed, the shim and the part shall be cleaned and the shim shall be reattached.

A1.8 Re-use of the shims is acceptable, provided they are not distorted when removed and intimate contact is achieved when replaced.

A1.9 **Determining Field Strength and Direction**—Use of the circle or cross configuration shims will indicate fields in any direction.

A1.9.1 In developing a magnetic particle procedure, first determine the locations the shims should be placed to ensure adequate coverage to monitor the field strength and direction, and then attach the shims.

A1.9.2 Using the continuous method, begin by starting with the amperage selection at a minimum level and increasing the amperage slowly until the shim indications are readily observed. When magnetized, one leg of the X will be indicated perpendicular to the field direction and the circle shim will show quadrants that are approximately perpendicular to the direction of the applied field.

A1.9.3 In multi-directional magnetization, longitudinal and circular fields shall be determined separately as follows:

A1.9.3.1 Field strength for the first direction shall be determined by slowly increasing the amperage until a satisfactory indication is observed on each shim.

A1.9.3.2 Record the amperage setting and indication results.

A1.9.3.3 Demagnetize the part and carefully clean the shims prior to determining the amperage in the next direction.

A1.9.3.4 Field strength for the second direction shall be determined by incrementally increasing the amperage until a satisfactory indication is observed on each shim.

A1.9.3.5 Record the amperage setting and indication results.

A1.9.4 Place the selector switch in the multi-directional mode and magnetize the part at the previously recorded settings. If the entire circle on the shims is observed, the fields are in balance. If any portion of the circle has a weak indication, adjust the amperage accordingly and repeat the field verification process until the magnetic fields are balanced.

A1.9.5 Use care when applying the suspension to the shims. Proper shim indications may not form unless the suspension is applied in a gentle manner.

A1.10 The shims are made of a low retentivity and high permeability material that cannot be used for indicating residual fields when developing magnetic particle testing procedures.

A1.11 In unidirectional applications, the actual field strength measurements can be obtained by placing a Hall Effect probe adjacent to the shim or at a nearby location where probe placement can easily be replicated.

A2. REFERENCE STANDARD NOTCHED SHIMS FOR MAGNETIC PARTICLE TESTING IN ACCORDANCE WITH AS 5371

A2.1 The following standard flawed shims are typically used to establish proper field direction and ensure adequate field strength during technique development in magnetic particle testing. The shims shown in Fig. A2.1 may be used to ensure the establishment of fields in the unidirectional magnetization method and to ensure the establishment and field balance in the multidirectional magnetization method.

A2.1.1 Except for shims illustrated in Fig. A2.3, the shims are available in two thicknesses, 0.002 in. [0.05 mm] and 0.004 in. [0.10 mm]. Thinner shims are used when the thicker shims cannot conform to the part surface in the area of interest.

A2.1.2 The shims are available in two sizes, 0.75 in. [19 mm] square for Figs. Fig. A2.1 and Fig. A2.2 and 0.79 in.

[20 mm] square of Fig. A2.3. The shims of Fig. A2.3 are cut, by the user, into four 0.395 in. [10 mm] square shims for use in restricted areas.

A2.1.3 Shims shall be low carbon steel, AMS 5062 or equivalent.

A2.1.4 Shims shall be used as specified in AS 5371. Shims are placed in the area(s) of interest with the notches toward the surface of the part being examined. Use enough shims by placing the shims in multiple areas to ensure proper field directions and strengths are obtained.

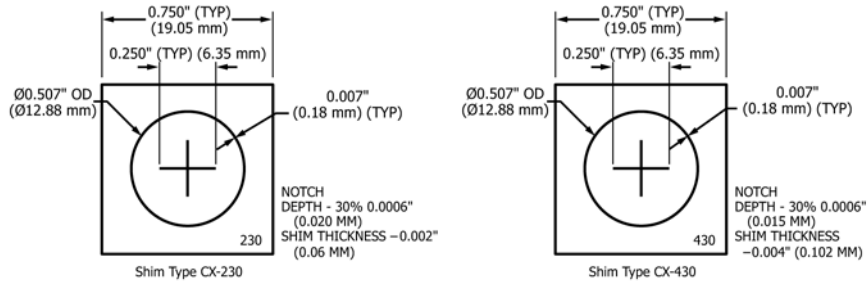

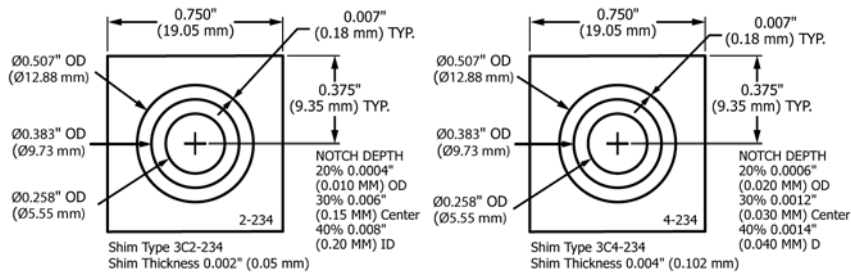

FIG. A2.2 Shims for Magnetic Particle Testing

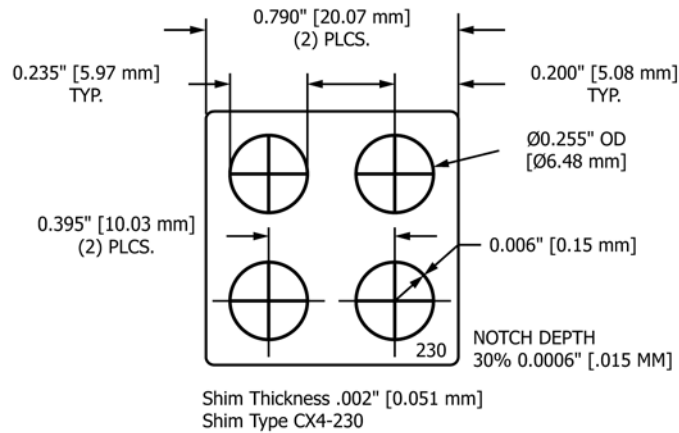

FIG. A2.3 Shims for Magnetic Particle Testing

A3. FLEXIBLE LAMINATED STRIPS FOR MAGNETIC PARTICLE TESTING

A3.1 Flexible laminated strips are typically used to ensure proper field direction during magnetic particle testing. The longitudinal axis of the strip should be placed perpendicular to the direction of the magnetic field of interest in order to generate the strongest particle indications on the strip.

A3.1.1 The strips are available in two types, General Use and Aerospace Use. Both types of strip contain a steel layer sandwiched between two brass plates that are 0.0020 in. [0.0508 mm] thick. The bottom brass layer acts as a lift-off of 0.0020 in. [0.0508 mm] from the examination surface. The brass is non-magnetic and functions only to provide lift-off and to protect the steel layer. The entire strip may have a polymeric coating for further protection.

A3.1.2 The longitudinal dimension of the strips is 1.95 in. [50 mm] and the width of the strip is 0.47 in. [12 mm].

A3.1.3 Both types of strips contain three longitudinal slots in the center steel layer.

A3.1.3.1 The widths of the slots in the General strip are 0.0075 in. [0.1905 mm], 0.009 in. [0.2286 mm], and 0.010 in. [0.254 mm].

A3.1.3.2 The widths of the slots in the Aerospace strip are 0.003 in. [0.0762 mm], 0.004 in. [0.1016 mm] and 0.005 in. [0.127 mm].

A3.1.4 The center steel layer of the strips is made of a high “μ” magnetic material.

A3.1.5 Strips shall be placed in the area(s) of interest part or surface being examined. Use enough strips, or place the strips in multiple areas to ensure that proper field directions are obtained.

A3.3 Instructions for the Use of Flexible Laminated Strips

A3.3.1 *Application of Strips*—Flexible laminated strips, as shown in Annex A3, require specific handling, attachment, and care for accurate indication of magnetic field direction.

A3.3.2 Strips are manufactured of high permeability carbon steel and must be protected from corrosion when not in use. They should be stored in a dry location. Before placing the strip onto the part, both the strip and part shall be clean and dry.



FIG. A3.1 The longitudinal lines represent the location of the slots cut into the center steel layer of either the General or Aerospace flexible laminated strips.

Leakage Flux from Slots in Magnetized Material

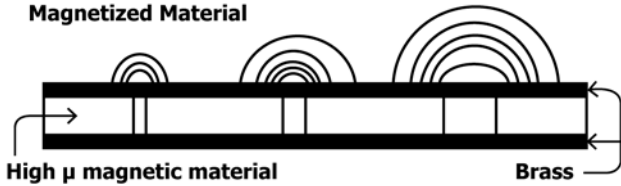

FIG. A3.2 A cross-sectional view illustrates the magnetic leakage flux generated by the slots in the central steel layer of a flexible laminated strip exposed to a magnetic field perpendicular to the strip axis.

A3.3.3 The strip shall be placed in intimate contact with material to be examined. The strip may be held in place manually or with the use of an adhesive or tape.

A3.3.3.1 If the strip is to be fastened to the part by using an adhesive or tape select one (such as Scotch Brand 191, 471, or 600 series) that prevents the magnetic particle suspension from entering between the strip and part.

A3.3.3.2 Tape may be used to secure the strip and shall have the following properties: (1) good adhesion to steel, (2) impervious to the suspension used, and (3) the tape shall be non-fluorescent (for fluorescent suspensions).

A3.3.3.3 If the tape becomes loose, allowing the suspension to seep under the strip, the tape and strip shall be carefully removed, the strip and the part shall be cleaned and the strip shall be reattached.

A3.3.3.4 Any tape or adhesive used to secure the strip to the part shall neither cover nor interfere with the visibility of the indications.

A3.3.4 Re-use of the strips is acceptable, provided they are not distorted when removed and intimate contact is achieved when replaced.

A3.3.5 Use care when applying the suspension to the strips. Proper strip indications may not form unless the suspension is applied in a gentle manner.

A3.3.6 The active center layer of the strips are made of a low retentivity and high permeability material.

A3.3.7 *Determining Field Direction*—Strips provide the strongest particle indications on the three lines when positioned such that the longitudinal axis of the strip is perpendicular to the applied magnetic field. A strip whose longitudinal axis is parallel to the applied field will not provide any particle indications. Refer to Fig. A3.3 and Fig. A3.4.

A3.3.7.1 To use the strips to determine field direction, first determine the location(s) for the strip(s) to be placed.

A3.3.7.2 Position a strip onto the surface so that it is perpendicular to the direction of the applied magnetic field.

(1) A second strip may be placed perpendicular to the first.

A3.3.7.3 Using the continuous method, begin by starting the amperage selection at a minimum level and increasing the

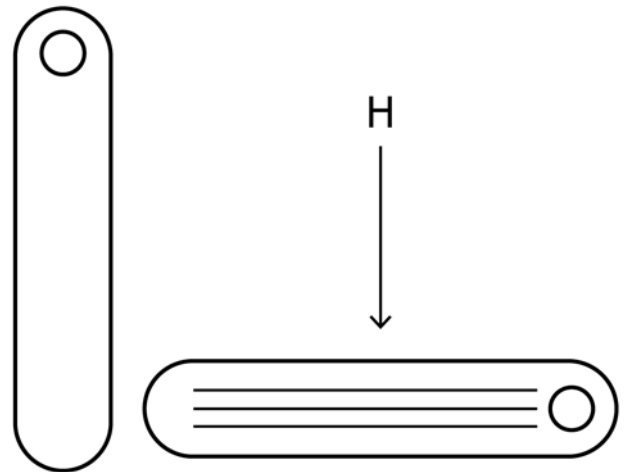

FIG. A3.3 Particle indications are strongest when applied magnetic field (H) is of sufficient strength and perpendicular to the longitudinal axis of the strip. No indications will form when the longitudinal axis is parallel to the applied field or the strength of H is insufficient.

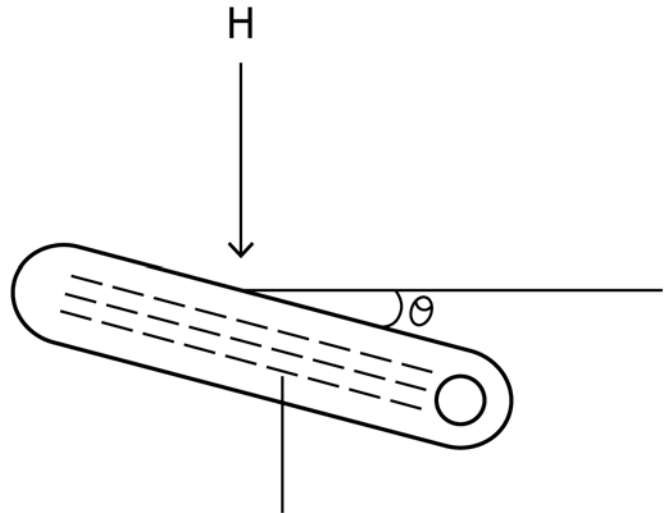

FIG. A3.4 Weak particle indications can mean that the longitudinal axis of the strip is at an angle (θ) from the applied magnetic field (H), or that the applied field is not strong enough to generate indications.

amperage slowly until the indications of the lines in one or both strip(s) are readily observed.

A3.3.7.4 If both strips show particle indications, the applied field is at an angle of between 30° to 60° to them. If no indications are visible in either strip when the field is applied, the field is not strong enough to generate indications.

A3.3.7.5 Actual field strength measurements (in the air at the point of measurement) can be obtained by placing a Hall Effect probe adjacent to the strip or at a nearby location where probe placement can easily be replicated.

A4. MEASUREMENT OF TANGENTIAL FIELD STRENGTH

A4.1 Care must be exercised when measuring the tangential applied field strengths as specified in 6.3.2. The active area of the Hall Effect probe should be no larger than 0.2 in. [5.1 mm] by 0.2 in. [5.1 mm] and should have a maximum center location 5 mm from the part surface. The plane of the probe must be perpendicular to the surface of the part and the magnetic field at the location of measurement to within 5 degrees. This is difficult to accomplish by hand orientation, therefore the probe should be held in a jig or fixture of some type. If the current is being applied in shots, or if alternating current or halfwave rectified current is being used, the electronic gaussmeter should be set to read the peak value during

the shot. The gaussmeter should have a frequency response of 300 Hz or higher. The direction and magnitude of the tangential field on the part surface can be determined by two measurements made at right angles to each other at the same spot. The gaussmeter probe leads should be shielded or twisted to prevent reading errors due to voltage induced during the large field changes encountered during magnetic particle testing.

NOTE A4.1—Lack of effective bandwidth could have a significant effect on the resultant value when measuring fields generated by pulse-width modulated magnetic particle testing equipment.

APPENDIXES

X1. SUITABILITY OF MATERIALS FOR MAGNETIC PARTICLE TESTING

X1.1 Some materials are far more suitable for magnetic particle testing than others. In some cases, liquid penetrant testing may be a more reliable testing method.

X1.2 Some of the precipitation hardening (PH) steels are austenitic in the annealed or low heat treat ranges. Austenitic materials cannot be examined by the magnetic particle testing method.

X1.3 Care must be taken with low permeability steels, such as the PH steels, to use a high enough amperage to provide proper field strength.

X1.4 Steels with very high permeability are easily magne-

tized but should not be examined with the residual method.

X1.5 Fig. X1.1 is a tabulation of stainless and corrosion resistant steels and their suitability for examination with the magnetic particle testing method.

X1.6 Aluminum and aluminum based alloys, copper and copper based alloys, and nickel based alloys cannot be examined by the magnetic particle testing method.

X1.7 All low-alloy carbon steels, 1000 series (1020, 1050, 1117, 1340 etc.), 4000 series (4130, 4330 4340M, and so forth), 5000, 6000, 8000, 9000 series, HY 80, HY 100, 9Ni-4Co, and maraging steels are ferro-magnetic and can be examined with the magnetic particle testing method.

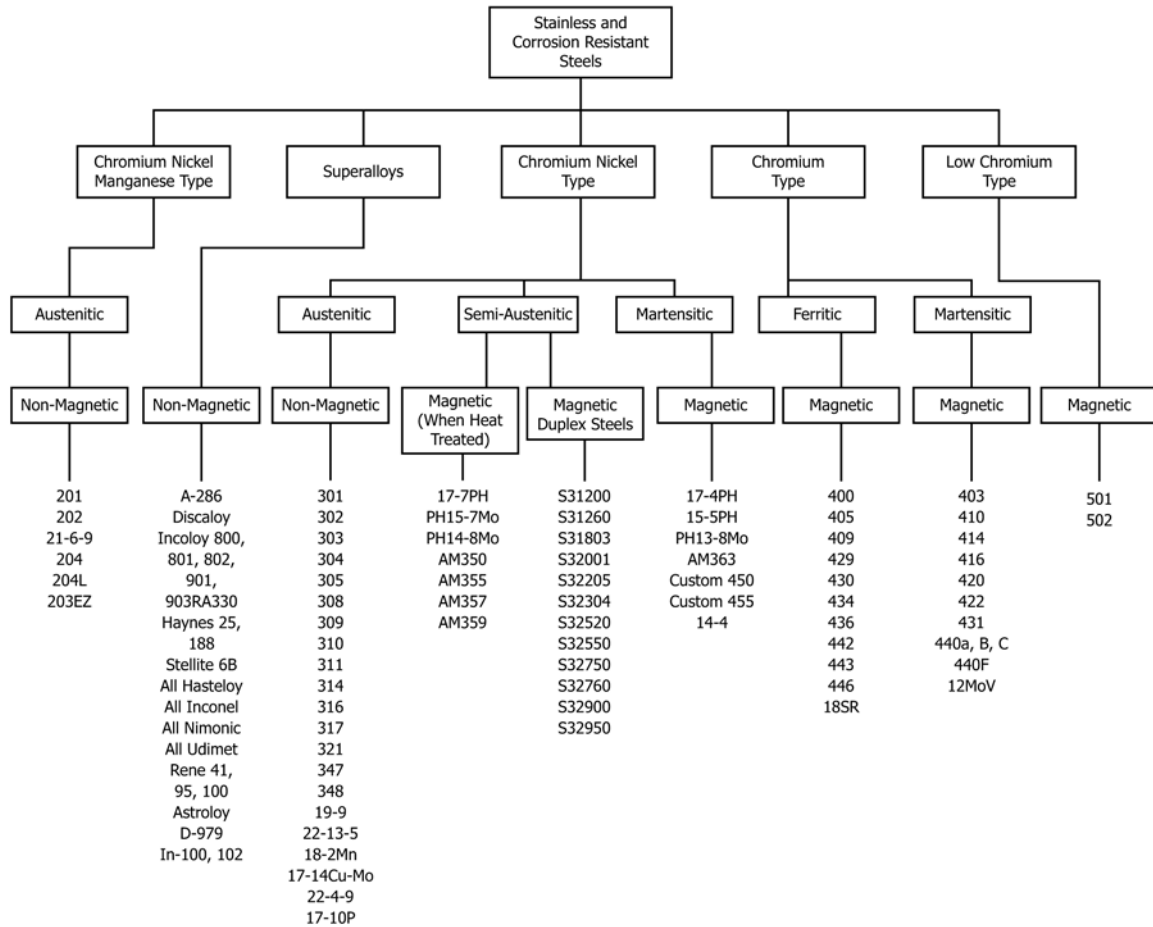

FIG. X1.1 Tabulation of Stainless and Corrosion Resistant Steels

X2. DEVICES FOR EVALUATION OF MAGNETIC PARTICLE EXAMINATION MATERIALS

X2.1 Scope

X2.1.1 This appendix illustrates several types of devices that can be used to evaluate, or compare the performance of both wet and dry magnetic particle testing materials. Particle performance evaluation devices may be used to: check for material degradation, compare difference materials, check the visibility of any material(s) under varying illumination conditions, and other types of comparisons.

NOTE X2.1—The devices discussed in this section shall not be re-magnetized in any manner or demagnetized in any manner. They contain some form of permanent magnetization. With suitable care, the magnetization within each device should not be subject to change over time.

X2.2 Devices

X2.2.1 *Encoded Magnetic Media*—The magnetic encoding process can generate magnetic gradients in a highly controlled manner. These gradients, when encoded into a media (that is, a magnetic stripe card) can be used as an indicator of magnetic particle performance. Fig. X2.1 illustrates how particles can be attracted to the encoded strip on the magnetic stripe card. For usage information, see X2.3.4.

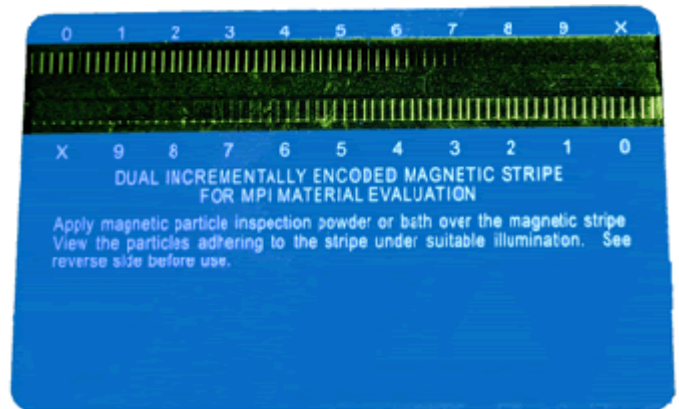

FIG. X2.1 Particle indications appear where magnetic gradients have been encoded in the magnetic strip of the card. In this case the gradients decrease in value from “0” (strongest) to “X” (weakest). Particle performance can be graded on the basis of the weakest indication.

X2.2.1.1 *Characteristics*—Magnetic stripe cards should be made in accordance with ISO 7810—Identification Cards—Physical Characteristics. The magnetic strip may be made of

either low-coercivity (lo-co) or high coercivity (hi-co) material, as designated by the manufacturer.

X2.2.1.2 Encoding Pattern—A constant encoding pattern, decaying encoding pattern, reverse decaying pattern, or other pattern may be encoded into the strip. See **Fig. X2.1** for a photograph of fluorescent particle indicators of decaying and reverse decaying encoding patterns.

X2.2.2 Permanently Magnetized Discs—Cracks in permanently magnetized disks provide the flux leakage required for magnetic particle indications. Observation of the intensity and brightness of indication allow a comparison or evaluation of particle performance. **Fig. X2.2** illustrates cracks that have been formed in the disk.

X2.2.3 Permanently Magnetized Blocks—The seam between two magnetically coupled blocks provide the flux leakage required for magnetic particle indications. The flux density decreases as the distance from the magnet increases and the resulting magnetic particle indication reduces. **Fig. X2.3** illustrates how a permanent magnet can be located to result in a particle indication along the seam between two precision formed steel blocks. The seam can be incremented so that the particle performance can be graded.

X2.3 Procedures Considerations

X2.3.1 Preparation—The surface of the device must be clean, dry, and free of any particles from previous examinations, fluid, or other contaminants or conditions that might interfere with the efficiency of the evaluation prior to the application of the testing material.

X2.3.2 Device Verification—Device should be checked with a new material or known material prior to use, to verify the device has not been magnetically altered. If the test indicates the magnetic properties of the device have been altered, it should be replaced. Contact the device manufacturer with regard to any magnetization or performance issues.

X2.3.3 Equipment and Procedures—The equipment requirements, examination condition and examination procedures for particle evaluation should be established and documented to the extent required in order to provide a standardized evaluation. The requirements may cover such things as UV-A distance and illumination requirements, visible light requirements, particle applicator and application procedure, the

use of contrast backgrounds, removal of excess particle and method of documenting results.

NOTE X2.2—Non-fluorescent particle results are particularly impacted by background color. A thin coating simulating examination condition background color may be considered in order to provide an additional aid in evaluating particle performance under actual examination conditions.

X2.3.4 Particle Application—Wet method and dry method materials should be consistent with the method of application that will be used for examinations.

X2.3.4.1 Wet Method Materials—Fluorescent or non-fluorescent particles suspended in a liquid vehicle at the required concentration should be applied as they would be used for examination, by gently spraying or flowing the suspension over the area to be examined or by immersion of the device in the suspension. Excess bath shall be allowed to flow away from the device. The device shall be observed under appropriate illumination for the formation of particle indications. Observations shall be noted as to the quality of particle indications and the clarity thereof.

X2.3.4.2 Dry Method Materials—Apply dry powder so that a light, uniform, dust-like coating settles on the surface of the device. The applicators should introduce the particles into the air in a manner such that they reach the part surface in a uniform cloud with a minimum of force. Excess particles should be removed by a gentle air current. The device shall be observed under appropriate illumination for the formation of particle indications. Observation shall be noted as to the quality of particle indications and the clarity thereof.

X2.3.5 Records—Particle indications may be recorded in accordance with subsection 6.6.

X2.3.6 Material Noncompliance—Evaluation of materials not meeting company standard should not be used for examination.

X2.3.7 Loss of Indications on a Permanently Magnetized Device—There are several circumstances in which magnetic particle indications may not be visible on the device and when indications are not visible, the subject particles should not be used for examination unless being verified as acceptable using a suitable alternate methodology.

X2.3.7.1 Concentration—The subject wet method particles may not have a sufficient level of concentration. In this case,



Figure A

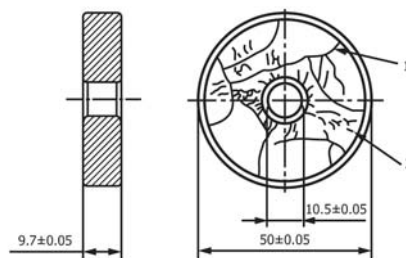

Figure B

FIG. X2.2 Typical dimensions (millimeters) of a disk containing surface cracks that has been permanently magnetized. In this case (1) indicates larger cracks formed by grinding and (2) indicates finer cracks caused by stress (induced by quenching)

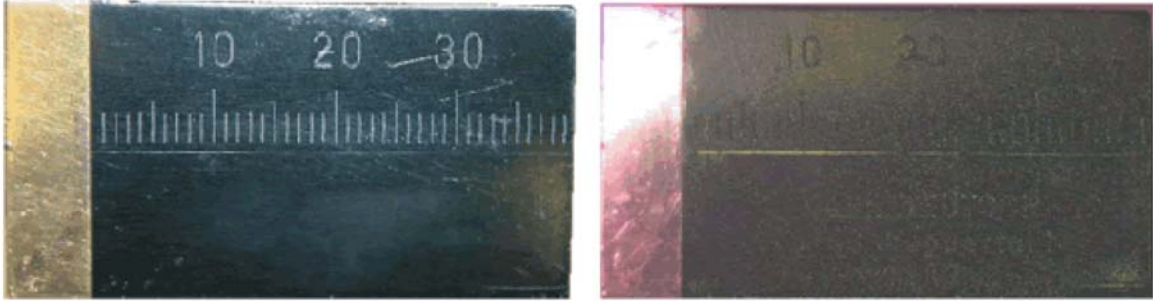
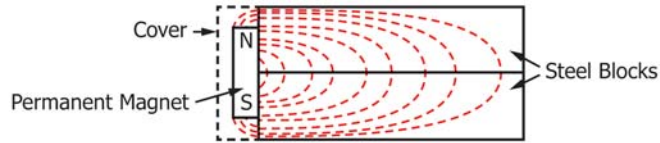

FIG. X2.3 One type of device containing a permanent magnet held next to two precision formed steel blocks with a brass cover. The seam between the steel blocks acts as a discontinuity; particles form an indication on the seam that is strongest close to the magnet and weakens with distance away from the magnet.

increase the concentration level of the bath and re-perform the check until the particles demonstrate suitable performance.

X2.3.7.2 Sensitivity—The subject particles may not provide necessary sensitivity. In this case, replace the material with a suitably sensitive material and re-perform the check until the particles demonstrate suitable performance.

X2.3.7.3 Erasure—The device has become magnetically erased. In this case, no discernible particle indication will appear. Repeat the check with another device, or sensitivity check, or both, until the particles demonstrate suitable performance.

Either destroy the device or report it to the manufacturer and follow the manufacturer's recommendations.

X2.3.8 Handling—After the visual examination has been made, the surface of the device should be cleaned of remaining fluid and particles in a manner non-detrimental to the device. When not in use, the device should be stored away from excessive heat and strong magnetic fields. Contact the device manufacturer with regard to any magnetization or performance issues.

X3. FORMULAS FOR DETERMINING PROPER CURRENT VALUES FOR CIRCULAR MAGNETISM

X3.1 Magnetization Current LevelsX3.1 The current values given in X3.2 and X3.3 are average current values and are applied directly to full-wave rectified current. For other types of current, the operator’s manual or the equipment manufacturer should be consulted.

X3.2 Prod Current LevelsX3.2 When using prods on material 3/4 in. [19 mm] in thickness or less, 90 to 115 A/in. of prod spacing [3.5 to 4.5 A/mm] shall be used. For material greater than 3/4 in. [19 mm] in thickness, 100 to 125 A/in. of prod spacing [4.0 to 5.0 A/mm] shall be used. Prod spacing shall not be less than 2 in. [50 mm] or greater than 8 in. [200 mm]. The effective width of the magnetizing field when using prods is one fourth of the prod spacing on each side of a line through the prod centers.

X3.3 Direct Circular MagnetizationX3.3 When magnetizing by passing current directly through the part the nominal current shall be 300 to 800 A/in. of part diameter [12 to 3 A/mm]. The diameter of the part shall be taken as the greatest distance between any two points on the outside circumference of the part. Currents will normally be 500 A/in. [20 A/mm] or lower, with the higher currents up to 800 A/in. [32 A/mm] being used to examine for inclusions or to examine low-permeability alloys such as precipitation-hardened steels. Amperages of less than 300 A/in. [12 A/mm] may be used when part configuration dictates and approval is obtained from the Level III.

X3.4 Internal Conductor Circular MagnetizationX3.4 Circular magnetization may be provided by passing current through a conductor that is positioned inside the part. If only the inside of the part is to be examined, the diameter shall be the greatest distance between two points, 180 degrees apart on the inside circumference. Otherwise, the diameter is determined as in X3.3.

X3.4.1 *Centrally Located Conductor*—When the axis of the internal conductor is located near the central axis of the part, the same current levels as given in X3.3 shall apply.

X3.4.2 *Offset Internal Conductor*—When the conductor that is positioned inside the part, is placed against the inside wall of the part, the current levels as given in X3.3 shall apply, except that the total diameter shall be the sum of the diameter of the central conductor plus twice the wall thickness of the part. The distance along the part circumference (interior) that may be effectively examined shall be taken as approximately four times the diameter of the internal conductor up to 360 degrees provided the presence of suitable fields is verified. The entire circumference shall be examined by rotating the part on the conductor, allowing for approximately a 10 % magnetic field overlap. See Fig. X3.1 for an illustration.

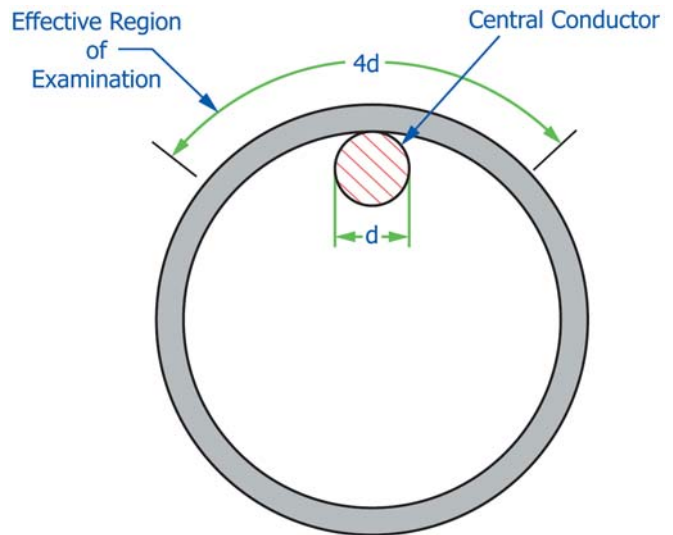

FIG. X3.1 The Effective Region of Examination When Using an Offset Internal Conductor is Equal to Four Times the Diameter of the Conductor as Indicated

X4. PIE FIELD INDICATOR AND TORROID FIELD FIXTURE

X4.1 See Fig. X4.1 and Fig. X4.2.

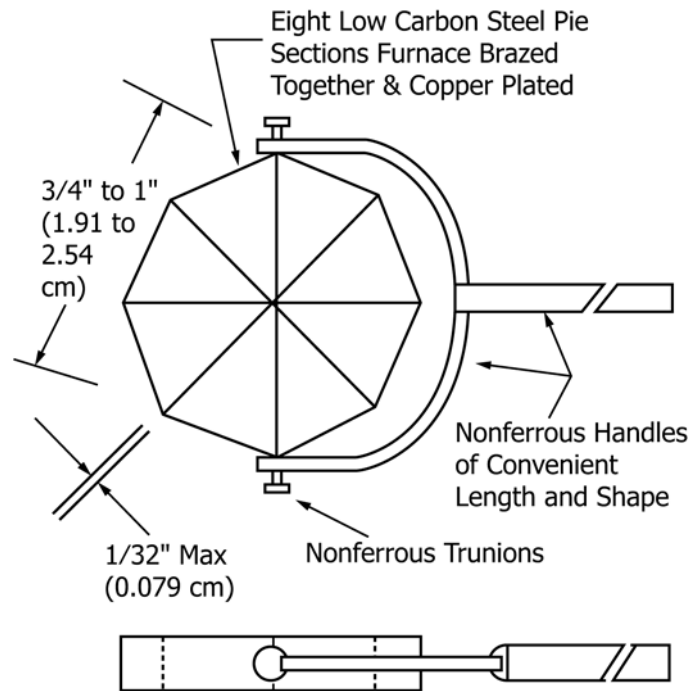

FIG. X4.1 Pie-field Indicator for Use in Magnetic Particle Testing

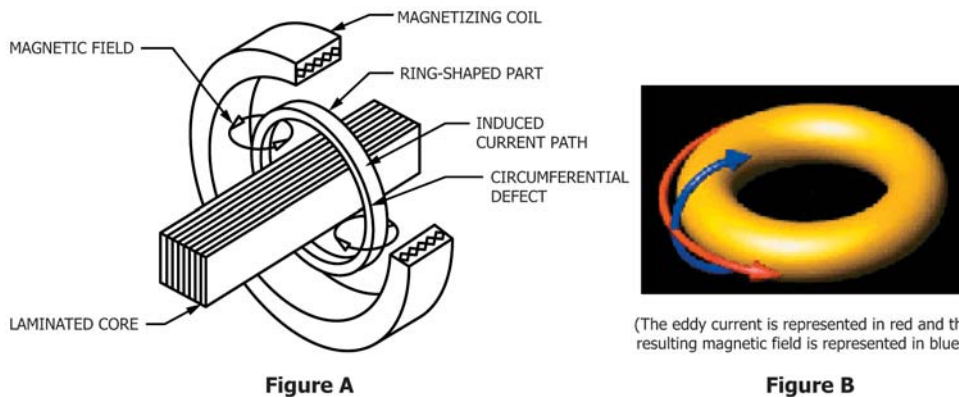

FIG. X4.2 Example of Induced Current Magnetization

NOTE 1—Only a changing magnetic field will generate a resulting eddy current in the ring-shaped part, such as when the magnetic field in the magnetizing coil suddenly collapses, or when using a moving waveform such as AC; no eddy current is produced in the part by a non-moving waveform. The resultant toroidal shaped magnetic field may be used to detect circumferential discontinuities in the part.

X5. EXAMINATION OF OILFIELD TUBULARS

X5.1 The following requirements should be used to induce residual magnetic fields in oilfield tubulars (tubing, casing, line pipe, and drill pipe).

X5.2 Circular Magnetism

X5.2.1 When capacitor-discharge units are used as magnetizing sources, the oilfield tubulars should be insulated from metal racks and adjacent oilfield tubulars to prevent arc burns.

X5.2.2 Partial demagnetization might occur in a magnetized length of oilfield tubulars if it is not sufficiently separated prior to magnetizing the next adjacent length. The distance used

should be at least 36 inches or as determined by the formula $I(0.006)$, whichever is greater, where I is the amperage applied.

X5.2.3 For battery or three-phase rectified-AC power supplies, a minimum magnetizing current of 300 Amps/in of specified outside diameter should be used.

X5.2.4 For full circumference examination of material with a specified outside diameter of 16 inches and smaller, centralization of the internal conductor is not required during magnetization.

X5.2.5 For capacitor-discharge units, see **Table X5.1** for magnetizing current requirements.

X5.2.6 The above requirements have been demonstrated and are based on empirical data¹¹ for oilfield grade ferromag-

¹¹ Moyer, M.C., "Magnetic Requirements of Oilfield Tubulars," *Materials Evaluation*, May 1986, 616-624.

TABLE X5.1 Capacitor Discharge Minimum Current

Number of Pulses	Capacitor Discharge Requirements	
	weight per foot in lb/ft	weight per meter in kg/m
Single	240 times specified	161 times specified
Double	180 times specified	121 times specified
	weight per foot in lb/ft	weight per meter in kg/m
Triple	145 times specified	97 times specified
	weight per foot in lb/ft	weight per meter in kg/m

netic tubulars and do not require verification, however, the amperage should be monitored during current application.

X5.3 Longitudinal Magnetization

X5.3.1 The number of coil turns and current required are imprecise but should not be less than 500 ampere-turns per inch of specified outside diameter. The current should be set as high as possible, but not so high as to cause furring of dry magnetic particles or immobility of wet magnetic particles.

X5.4 Examination of Coated Tubulars

X5.4.1 Finished tubulars are often coated with a light varnish to prevent surface corrosion. This condition is generally acceptable and does not affect magnetic particle examination.

X5.5 Field Examination Lighting

X5.5.1 For some field examinations using nonfluorescent particles, visible light intensities as low as 50 foot candles (538 lux) may be used when approved by the Level III.

ASTM International takes no position respecting the validity of any patent rights asserted in connection with any item mentioned in this standard. Users of this standard are expressly advised that determination of the validity of any such patent rights, and the risk of infringement of such rights, are entirely their own responsibility.

This standard is subject to revision at any time by the responsible technical committee and must be reviewed every five years and if not revised, either reapproved or withdrawn. Your comments are invited either for revision of this standard or for additional standards and should be addressed to ASTM International Headquarters. Your comments will receive careful consideration at a meeting of the responsible technical committee, which you may attend. If you feel that your comments have not received a fair hearing you should make your views known to the ASTM Committee on Standards, at the address shown below.

This standard is copyrighted by ASTM International, 100 Barr Harbor Drive, PO Box C700, West Conshohocken, PA 19428-2959, United States. Individual reprints (single or multiple copies) of this standard may be obtained by contacting ASTM at the above address or at 610-832-9585 (phone), 610-832-9555 (fax), or service@astm.org (e-mail); or through the ASTM website (www.astm.org). Permission rights to photocopy the standard may also be secured from the Copyright Clearance Center, 222 Rosewood Drive, Danvers, MA 01923, Tel: (978) 646-2600; http://www.copyright.com/