



Standard Specification for Preparation and Verification of Clay Blocks Used in Ballistic-Resistance Testing of Torso Body Armor¹

This standard is issued under the fixed designation E3004; the number immediately following the designation indicates the year of original adoption or, in the case of revision, the year of last revision. A number in parentheses indicates the year of last reapproval. A superscript epsilon (ϵ) indicates an editorial change since the last revision or reapproval.

^ε¹ NOTE—Editorial corrections made throughout in August 2016.

INTRODUCTION

At the time when work on this specification was undertaken, different ballistic-resistant body armor test protocols required different impactors for verification of the clay blocks placed behind the test items, and the lack of detailed guidance about the clay blocks resulted in different practices for preparation and verification. To improve laboratory-to-laboratory consistency, major stakeholders sought to harmonize practices related to the preparation and verification of the clay blocks used for testing of ballistic-resistant body armor.

1. Scope

1.1 The purpose of this specification is to provide a standardized method for preparation and verification of backing assemblies used in ballistic-resistant torso body armor testing and to reduce variability within and between laboratories.

1.2 The backing assembly is a clay block that contains *ROMA Plastilina No. 1*² clay as the backing material. The clay serves as a witness material and provides a measurable indication of test item performance.

1.3 This specification is primarily directed toward test laboratories but may be applicable to body armor manufacturers, researchers, and end users performing ballistic-resistance testing of body armor.

1.4 *Units*—The values stated in SI units are to be regarded as standard. The values given in parentheses are mathematical conversions to non-SI units that are provided for information only.

1.5 *This standard does not purport to address all of the safety concerns, if any, associated with its use. It is the responsibility of the user of this standard to establish appropriate safety and health practices and determine the applicability of regulatory limitations prior to use.*

2. Referenced Documents

2.1 *ASTM Standards*:³

E3005 Terminology for Body Armor

2.2 *NIST Standard*:⁴

NIST Special Publication 330 The International System of Units (SI), 2008 Edition, Barry N. Taylor and Ambler Thompson, Editors

3. Terminology

3.1 The terms and definitions of Terminology **E3005** apply for the following terms: *backing assembly*, *backing fixture*, *backing material* and *test item*.

3.2 *Definitions of Terms Specific to This Standard*:

3.2.1 *backing assembly, n*—a backing fixture filled with backing material. For example, a clay block is a type of a backing assembly.

3.2.2 *backing fixture, n*—any apparatus designed to hold or contain the backing material(s) for a specific test.

3.2.3 *backing material, n*—the substance placed behind the test item during testing which is intended to be a witness material and which may provide a measurable indication of test item performance.

3.2.4 *bridge gauge, n*—an assembly used for measuring that consists of a depth gauge and supports that rest on opposite sides of the backing fixture.

¹ This specification is under the jurisdiction of ASTM Committee E54 on Homeland Security Applications and is the direct responsibility of Subcommittee E54.04 on Personal Protective Equipment (PPE).

Current edition approved Nov. 1, 2015. Published November 2015. DOI: 10.1520/E3004-15E01.

² U.S. Government standards require ROMA Plastilina No. 1[®], from Sculpture House, Inc., as the backing material for ballistic-resistance testing.

³ For referenced ASTM standards, visit the ASTM website, www.astm.org, or contact ASTM Customer Service at service@astm.org. For *Annual Book of ASTM Standards* volume information, refer to the standard's Document Summary page on the ASTM website.

⁴ Available from National Institute of Standards and Technology (NIST), 100 Bureau Dr., Stop 1070, Gaithersburg, MD 20899-1070, <http://www.nist.gov>.

3.2.5 *clay block, n*—a type of backing assembly in which the backing material is ROMA Plastilina No. 1® modeling clay. See Fig. 1.

3.2.6 *clay package, n*—the smallest unit of wrapped and labeled clay as received from the supplier.

3.2.7 *depth gauge, n*—instrument (for example, caliper) used to measure the indentations in the backing material caused by the impactor.

3.2.8 *impactor, n*—cylindrical device, used during verification of the backing material, having specified dimensions and one hemispherical end.

3.2.9 *striking device, n*—a device used on a clay block to establish an appropriate, flat surface on the clay backing material with respect to the backing fixture edges.

3.2.10 *test item, n*—a single article intended for testing. Examples may include one panel, one plate, or one shoot pack.

4. Significance and Use

4.1 U.S. Department of Defense and U.S. Department of Justice standards for assessing the performance of ballistic-resistant torso body armor require the use of backing assemblies made with Roma Plastilina No. 1®. It can be demonstrated that the way the clay block is handled prior to and during ballistic testing can have a significant influence on deformation of the clay when a test item is struck by a projectile during testing.

4.2 At the time when work on this specification was undertaken, different ballistic-resistant body armor test protocols required different impactors for verification of the clay blocks placed behind the test items, and the lack of detailed guidance about the clay blocks resulted in different practices for preparation and verification. To improve laboratory-to-laboratory consistency, major stakeholders sought to harmonize practices related to the preparation and verification of the clay blocks used for testing of ballistic-resistant body armor.

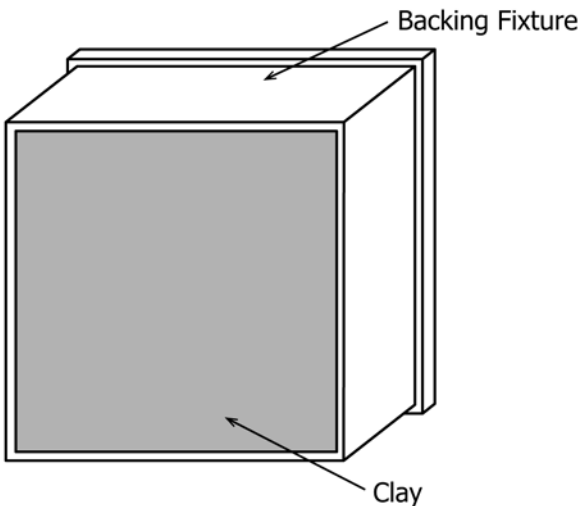

FIG. 1 Clay Block

5. Equipment

5.1 The equipment used for preparation and verification of clay blocks shall be as described below:

5.1.1 *Backing Fixture*—The backing fixture shall be a rigid, metal frame with a plywood bottom. The inside dimensions of the metal frame shall be 610 ± 2 mm (24.0 ± 0.08 in.) by 610 ± 2 mm (24.0 ± 0.08 in.) with a depth of 140 ± 2 mm (5.5 ± 0.08 in.). The top and bottom edges of the metal frame shall be planar. Plywood, of any grade, that is nominally “¾ in.” or “18 mm,” shall be attached to the outside of the metal frame to form the bottom of the fixture and shall be removable. See Fig. 2.

5.1.2 *Backing Fixture Liner*—A liner, such as 0.08 to 0.13 mm (3 to 5 mil) polyethylene sheeting, shall be inserted into the backing fixture to prevent the clay oils from coming into contact with the plywood. The liner shall be placed against the plywood bottom of the backing fixture and shall not extend up the inside surfaces of the metal frame.

NOTE 1—The backing fixture liner is intended to be a barrier between the clay and the plywood and may be sheeting, a coating (for example, spray, paint, shellac), or any other barrier that prevents leaching of oil into the plywood.

5.1.3 *Bridge Gauge*—The bridge gauge shall be a rigid assembly that rests on two parallel strike face edges of the backing fixture and supports a depth gauge that can slide back and forth on the assembly to measure depths across the surface of the backing material. The bridge gauge (independent of the backing fixture) shall have a resolution of 0.01 mm or better with an accuracy of ±0.1 mm or better.

5.1.4 *Conditioning Chamber*—The chamber shall be temperature controlled, be sufficiently large, and have continuous circulation of air with the intention of uniformly heating all clay blocks in the chamber.

5.1.5 *Impactor:*

5.1.5.1 The impactor shall be a steel, constant diameter cylinder having a hemispherical end of diameter equal to the cylinder diameter and a smooth transition from the hemispherical end to the cylinder body. A drawing specifying the dimensions of the impactor is provided in Fig. 3.

5.1.5.2 The impactor mass shall be 1.0 ± 0.005 kg (2.20 ± 0.01 lb_m).

NOTE 2—To achieve the required mass, the length of the entire impactor

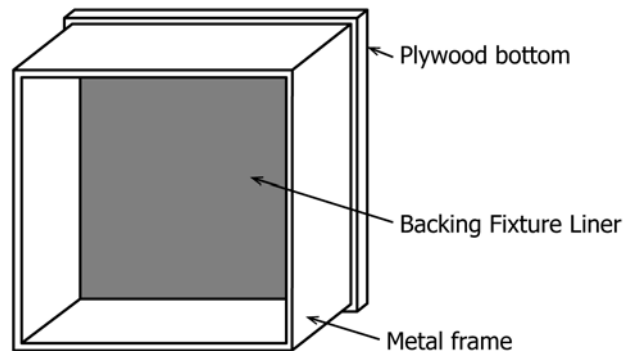

NOTE 1—The plywood bottom is shown larger than the metal frame for illustrative purposes only.

FIG. 2 Backing Fixture

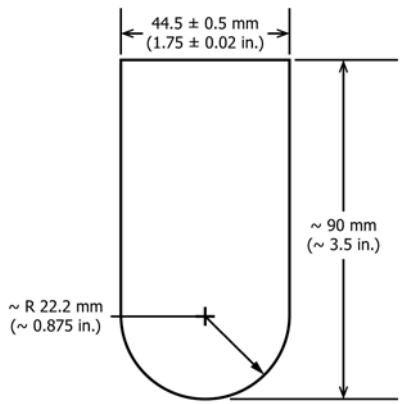

- Notes:
1. The material shall be steel with a smooth finish.
 2. There shall be a smooth transition from the hemispherical end to the cylindrical body.

FIG. 3 Impactor

will be approximately 90 mm (3.5 in.).

5.1.6 *Striking Device*—The striking device shall be a metal, straight-edged blade capable of spanning two parallel strike face edges of the backing fixture so that the backing fixture serves as the reference for the clay block surface. The striking device shall be sufficiently rigid to facilitate creation of a flat clay surface that is even with the strike face edges of the backing fixture.

5.1.7 *Template*—A circular template shall be used to mark the impact locations on the surface of the clay. The template shall fit within the internal backing fixture dimensions. The impact location centers on the template shown in Fig. 4 are spaced approximately 50 mm (2 in.), 127 mm (5 in.), and 203 mm (8 in.) from the center and approximately 120° apart.

5.1.7.1 The purpose of the template is to ensure that the three impact locations meet the drop spacing requirements below:

- (1) Minimum of 76 mm (3.0 in.) from backing fixture edge to nearest indentation edge.
- (2) Minimum of 152 mm (6.0 in.) between impactor indentation centers.

5.1.8 *Test Setup*—The test setup for clay block verification shall consist of a guide tube through which the impactor is dropped (hemispherical end down) onto a clay block that rests

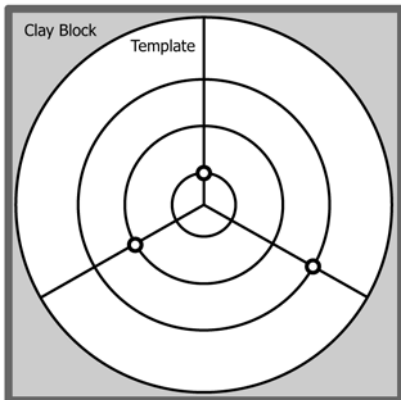

FIG. 4 Template for Impact Locations

on a movable support. See Fig. 5 for an example test setup including guide tube dimensions and spacing between the guide tube and the clay block surface.

5.1.8.1 *Guide Tube*—The guide tube length shall be such that the impactor is within the tube prior to release and entirely out of the tube at impact with the clay block surface. The guide tube length shall be sufficient to minimize yaw of the impactor at the clay surface. The guide tube inside diameter shall be sized to allow the impactor to drop freely and minimize yaw. The guide tube shall be solidly mounted to a fixed surface.

NOTE 3—Holes or slots along the length of the guide tube may be useful to limit effects of air on the impactor as it drops through the tube.

5.1.8.2 *Movable Support*—The support upon which the clay block rests shall allow positioning of the clay block to set the impact locations, keep the clay block level, keep the drop distance constant when the clay block is positioned for different impact locations, and prevent the block from moving vertically due to the impact from the impactor.

5.1.9 *Velocity Measurement Equipment*—The velocity measurement equipment shall be capable of measuring velocities in at least the range of interest with a resolution of 0.005 m/s or better and an accuracy of 0.01 m/s or better. See Appendix XI for Velocity Measurement Guidance.

6. Procedures

6.1 Characterization of Clay Block Verification Test Setup:

6.1.1 Perform the following steps at installation of a new test setup (see 5.1.8) and periodically thereafter. These steps shall be performed without the clay block or its movable support in the test setup.

6.1.1.1 Verify that the guide tube is straight, plumb, and rigid.

6.1.1.2 Verify that the guide tube is solidly mounted so that it remains in the verified position.

6.1.1.3 To verify the performance of the test setup, the velocity of the impactor at the clay surface is required to be between 6.15 to 6.27 m/s. Perform an appropriate number of

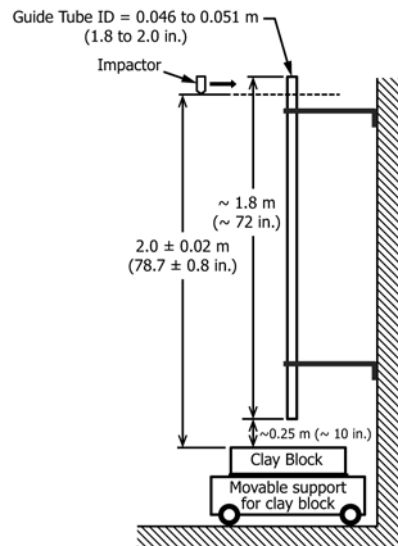

FIG. 5 Example Test Setup

impactor drops through the guide tube to determine the drop distance at which a velocity in this range is achieved at the expected point of impact. The drop distance shall be measured from the impactor tip (rounded end) to the expected point of impact.

6.1.1.4 Record the drop distance. The drop distance shall be within 2 ± 0.02 m.

NOTE 4—If the measured drop distance does not meet this requirement, the test setup should be adjusted until the measured velocity and drop distance are within the required ranges.

6.1.2 The value of the measured drop distance shall be used during clay block verifications. The velocity is not required to be measured during actual clay block verifications.

NOTE 5—Provision should be made to ensure that the impactor is dropped the determined drop distance each time, such as by the use of a hard stop at the top of the guide tube.

6.2 Clay Block Preparation Procedures:

6.2.1 New Clay Block Assembly:

6.2.1.1 Fill the backing fixture with clay following the steps below:

(1) Open each clay package, and soften the clay by heating it; working it with kneading, pounding, or tamping; or combinations thereof.

(2) Press clay into the backing fixture, using a manual device (for example, mallet) or a machine (for example, hydraulic press or powered hammering tool), one layer at a time starting in the corners. One layer of flattened clay should be added at a time, and then pressed and blended into the previous layers to prevent voids.

(3) Continue layering, pressing, and blending of clay until the depth of the clay exceeds the strike face edges of the backing fixture.

(4) Remove excess clay at the surface by drawing the striking device at least once across the full length of parallel edges of the backing fixture.

NOTE 6—The striking device should be drawn across the same edges that the bridge gauge rests on during measuring and should be drawn in the same direction every time.

NOTE 7—If the striking device is drawn more than once and in orthogonal directions, the resultant clay surface must be planar.

(5) Visually verify that the clay surface is flat and flush with the backing fixture strike face edges. If voids in the surface are visible, fill those voids with additional clay, and repeat steps (4) and (5) until the surface of the clay is flat with no visible voids.

(6) Store the clay block indoors at room temperature or in the conditioning chamber.

6.2.2 Determination of Conditioning Chamber Temperature:

6.2.2.1 Set the conditioning chamber temperature at an initial temperature chosen by the test laboratory.

6.2.2.2 Place the clay block into the conditioning chamber.

6.2.2.3 Heat the clay block according to the requirements below:

(1) New clay blocks shall be heated for at least 24 hours.

(2) Any clay block that has been out of the conditioning chamber for more than one hour shall be heated for at least

three times the time out of the chamber. Every clay block shall be heated for no less than three hours.

6.2.2.4 Record the conditioning chamber temperature.

6.2.2.5 Remove the clay block from the conditioning chamber and promptly perform the procedure specified in 6.3.

6.2.2.6 Perform the procedure specified in 6.4.

6.2.2.7 If necessary, adjust the temperature of the conditioning chamber based on the indentation depth measurements in the clay and repeat steps 6.2.2.2 – 6.2.2.7.

6.2.3 Clay Block Temperature Conditioning Procedure:

6.2.3.1 Prior to performing a clay block verification procedure, the clay block shall be heated to uniform temperature as described below:

(1) Verify that the conditioning chamber is set to the temperature determined in 6.2.2.

(2) Place one or more clay blocks into the conditioning chamber such that there is air flow around each clay block.

(3) Heat each clay block according to the requirements below:

(a) New clay blocks shall be heated for at least 24 hours.

(b) Any clay block that has been out of the conditioning chamber shall be reheated for no less than three hours.

(c) Any clay block that has been out of the conditioning chamber for more than one hour shall be reheated for at least three times the time out of the chamber but not more than 24 hours.

(d) Twenty four hours is the maximum time required for reheating any clay block, but a clay block may remain in the chamber indefinitely.

6.3 Clay Block Verification Procedure: Prior to Ballistic Testing:

6.3.1 Overview:

6.3.1.1 Each clay block shall be verified to ensure it meets the requirements prior to use as a backing assembly for ballistic testing of body armor. This method is based on dropping the impactor through a guide tube onto the surface of a conditioned clay block. The indentation created by the drop is then measured.

6.3.2 Test Method:

6.3.2.1 Visually inspect the test setup for proper alignment and absence of clay residue on the impactor, guide tube, depth gauge, or other relevant items.

6.3.2.2 Remove a conditioned clay block from the conditioning chamber. Impactor drops shall begin within ten minutes of removing the clay block from the conditioning chamber.

6.3.2.3 Visually inspect the surface of the clay block. The clay block surface shall be homogeneous and free of defects.

NOTE 8—The intention of this step is to avoid using a clay block that is filled with old clay having potentially degraded properties. Examples of items to inspect for include cracking, abnormal coloring, oil deposits, and significant separation from edges of the backing fixture.

6.3.2.4 The clay block shall be removed from service if the surface requirements of section 6.3.2.3 are not met, and all clay in that clay block shall be discarded.

6.3.2.5 Working the clay surface is not permitted during the verification procedure.

NOTE 9—Striking the clay surface is not considered to be working the clay surface.

6.3.2.6 Remove excess clay at the surface by drawing the striking device at least once across the full length of parallel edges of the backing fixture.

NOTE 10—The striking device should be drawn across the same edges that the bridge gauge rests on during measuring and should be drawn in the same direction every time.

NOTE 11—If the striking device is drawn more than once in orthogonal directions, the resultant clay surface must be planar.

6.3.2.7 Visually verify that the clay surface is smooth and free of defects before moving to the next step.

6.3.2.8 Place the drop template on the clay surface in an arbitrary rotational position. Mark the surface of the clay block (for example, by nicking the surface, laser marking, applying ink) to indicate the drop target positions, and remove the template.

NOTE 12—The requirement to place the drop template at an arbitrary rotational position is included for the purpose of ensuring different impact locations for each subsequent verification.

6.3.2.9 Place the clay block on the movable support and move it into the test setup. Verify that the surface of the clay block is level.

6.3.2.10 Position the clay block beneath the guide tube such that the guide tube is directly above one of the marks on the clay surface.

6.3.2.11 Measure and record the drop distance.

6.3.2.12 Drop the impactor through the guide tube onto the clay block, ensuring that the movable support does not move during the drop. The impactor shall be dropped three times, once on each of the marks on the clay surface.

6.3.2.13 Position the bridge gauge on the sides of the backing fixture, and zero the depth gauge to a backing fixture strike face edge. The clay should not be struck with the striking device (that is, resurfaced) prior to making the measurements. Measure the depth of each indentation using the depth gauge, ensuring that the depth is measured at the deepest point of the indentation without disturbing the clay. The measurement accuracy shall be ± 1.0 mm or better. Record the three indentation measurements.

6.3.3 Acceptance Criterion:

6.3.3.1 Each indentation depth measurement shall be within the range of 22.0 to 28.0 mm (0.866 to 1.102 in.). The measurements shall not be rounded off.

6.4 Clay Block Repair:

6.4.1 Repair the clay block by filling the indentations with clay that has been in the conditioning chamber for at least 24 hours. Repairs shall be accomplished by pressing in pieces of clay until the depth of clay exceeds the strike face edges of the backing fixture. Use caution to completely fill the indentation without leaving any voids.

6.4.2 Remove excess clay at the surface by drawing the striking device at least once across the full length of parallel edges of the backing fixture.

NOTE 13—The striking device should be drawn across the same edges that the bridge gauge rests on during measuring and should be drawn in the same direction every time.

NOTE 14—If the striking device is drawn more than once and in orthogonal directions, the resultant clay surface must be planar.

6.4.3 Visually verify that the clay surface is flat and flush with the backing fixture strike face edges. If voids in the surface are visible, fill the voids with additional clay, and repeat steps 6.4.2 and 6.4.3 until the surface of the clay is flat with no visible voids.

6.5 Clay Blocks that Fail to Meet the Acceptance Criteria of 6.3.3:

6.5.1 If the depth measurements are too shallow, work the entire clay block surface by pounding, tamping, or similar methods.

6.5.2 If the depth measurements are too deep, go to step 6.5.3.

6.5.3 Perform clay block repair according to 6.4.

6.5.4 Perform clay block temperature conditioning according to 6.2.3.

6.6 Clay Block Verification Procedure: Between Test Items:

6.6.1 Overview:

6.6.1.1 Use of this procedure is optional. If the user requires this procedure to be followed, then each clay block shall be verified between test items to ensure it meets the requirements.

6.6.2 Test Method:

6.6.2.1 Promptly following the last impact of the test item and measurement of the resultant backface deformations, perform clay block repair according to 6.4.

6.6.2.2 Place the drop template on the clay surface and rotate it to an arbitrary rotational position. A different angle shall be used for each subsequent verification. Mark the surface of the clay block (for example, by nicking the surface, laser marking, applying ink) to indicate the drop target positions, and remove the template. Position the clay block beneath the guide tube such that the guide tube is directly above one of the marks on the clay surface.

NOTE 15—The requirement to place the drop template at an arbitrary rotational position is included for the purpose of ensuring different impact locations for each subsequent verification.

6.6.2.3 Verify that the surface of the clay block is level.

6.6.2.4 Drop the impactor through the guide tube onto the clay block. The impactor shall be dropped three times, once on each of the marks on the clay surface.

6.6.2.5 Position the bridge gauge on the sides of the backing fixture, and zero the depth gauge to a backing fixture strike face edge. The clay should not be struck with the striking device (that is, resurfaced) prior to making the measurements. Measure the depth of each indentation using the depth gauge, ensuring that the tip of the depth gauge is at the deepest point of the indentation without disturbing the clay. The measurement accuracy shall be ± 1.0 mm or better. Record the three indentation measurements.

6.6.3 Acceptance Criterion:

6.6.3.1 Each indentation depth measurement shall be within the range of 22.0 to 28.0 mm (0.866 to 1.102 in.). The measurements shall not be rounded off.

6.7 Clay Block Verification Procedure: After Final Shot on Clay Block:

6.7.1 Overview:

6.7.1.1 Use of this procedure is optional. If the user requires this procedure to be followed, then each clay block shall be

verified promptly following the final shot on the clay block to ensure the clay block met the requirements for ballistic testing.

6.7.2 Test Method:

6.7.2.1 Promptly following the final shot on the clay block and measurement of the resultant backface deformations, perform this test method on the clay block. Do not repair the clay block.

6.7.2.2 Remove excess clay at the surface by drawing the striking device at least once across the full length of parallel edges of the backing fixture.

NOTE 16—The striking device should be drawn across the same edges that the bridge gauge rests on during measuring and should be drawn in the same direction every time.

NOTE 17—If the striking device is drawn more than once and in orthogonal directions, the resultant clay surface must be planar.

6.7.2.3 Identify three locations on the clay block surface where the impactor can be dropped on undisturbed clay and meet the drop spacing requirements below to the extent possible, given that ballistic impact deformations are present:

(1) Minimum of 76 mm (3.0 in.) from backing fixture edge to nearest indentation edge.

(2) Minimum of 152 mm (6.0 in.) between impactor indentation centers.

(3) Minimum of 76 mm (3.0 in.) between the edge of each impactor indentation and the edge of each ballistic impact location.

6.7.2.4 Mark the surface of the clay block (for example, by nicking the surface, laser marking, applying ink) to indicate the drop target positions.

6.7.2.5 Drop the impactor through the guide tube onto the clay block in each of the three locations.

6.7.2.6 Position the bridge gauge on the sides of the backing fixture, and zero the depth gauge to a backing fixture strike face edge. The clay should not be struck with the striking device (that is, resurfaced) prior to making the measurements. Measure the depth of each indentation using the depth gauge, ensuring that the depth is measured at the deepest point of the indentation without disturbing the clay. The measurement accuracy shall be ± 1.0 mm or better. Record the three indentation measurements.

6.7.3 Acceptance Criterion:

6.7.3.1 Each indentation depth measurement shall be within the range of 22.0 to 28.0 mm (0.866 to 1.102 in.). The measurements shall not be rounded off.

7. Keywords

7.1 ballistic testing; body armor; clay block

APPENDIX

(Nonmandatory Information)

X1. VELOCITY MEASUREMENT DETAILS

X1.1 The velocity (v_f) of the impactor shall be the velocity at the location of the clay block surface. If it is not possible to measure velocity at the location of the clay block surface, then the velocity can be measured between the bottom of the guide tube and the location of the clay block surface. That value can be used in the equation below to calculate the velocity at the location of the clay block surface:

$$v_f^2 = v_i^2 + 2gd_a \quad (\text{X1.1})$$

where:

v_f = velocity at the location of the clay block surface (m/s),

v_i = velocity at location of measurement (m/s),
 d_a = adjustment distance between the measurement location and the location of the clay block surface (m), and
 g = gravity (m/s^2)

NOTE X1.1—If the value of g for local gravity is not known, then value of g shall be standard gravity, 9.80665 m/s^2 . (NIST Special Publication 330)

ASTM International takes no position respecting the validity of any patent rights asserted in connection with any item mentioned in this standard. Users of this standard are expressly advised that determination of the validity of any such patent rights, and the risk of infringement of such rights, are entirely their own responsibility.

This standard is subject to revision at any time by the responsible technical committee and must be reviewed every five years and if not revised, either reapproved or withdrawn. Your comments are invited either for revision of this standard or for additional standards and should be addressed to ASTM International Headquarters. Your comments will receive careful consideration at a meeting of the responsible technical committee, which you may attend. If you feel that your comments have not received a fair hearing you should make your views known to the ASTM Committee on Standards, at the address shown below.

This standard is copyrighted by ASTM International, 100 Barr Harbor Drive, PO Box C700, West Conshohocken, PA 19428-2959, United States. Individual reprints (single or multiple copies) of this standard may be obtained by contacting ASTM at the above address or at 610-832-9585 (phone), 610-832-9555 (fax), or service@astm.org (e-mail); or through the ASTM website (www.astm.org). Permission rights to photocopy the standard may also be secured from the Copyright Clearance Center, 222 Rosewood Drive, Danvers, MA 01923, Tel: (978) 646-2600; http://www.copyright.com/