



Standard Test Method for Determination of Abrasion Resistance of Iron Ore Pellets and Sinter by the Tumbler Test¹

This standard is issued under the fixed designation E279; the number immediately following the designation indicates the year of original adoption or, in the case of revision, the year of last revision. A number in parentheses indicates the year of last reapproval. A superscript epsilon (ϵ) indicates an editorial change since the last revision or reapproval.

1. Scope

1.1 This test method covers a relative measure of the resistance of iron ore pellets and sinter to degradation by impact and by abrasion.

1.2 The values stated in SI units are to be regarded as standard. The values given in parentheses are mathematical conversions to inch-pound units that are provided for information only and are not considered standard.

1.3 *This standard does not purport to address all of the safety concerns, if any, associated with its use. It is the responsibility of the user of this standard to establish appropriate safety and health practices and determine the applicability of regulatory limitations prior to use.*

2. Referenced Documents

2.1 *ASTM Standards:*²

[E135 Terminology Relating to Analytical Chemistry for Metals, Ores, and Related Materials](#)

[E276 Test Method for Particle Size or Screen Analysis at No. 4 \(4.75-mm\) Sieve and Finer for Metal-Bearing Ores and Related Materials](#)

[E389 Test Method for Particle Size or Screen Analysis at No. 4 \(4.75-mm\) Sieve and Coarser for Metal-Bearing Ores and Related Materials](#)

[E877 Practice for Sampling and Sample Preparation of Iron Ores and Related Materials for Determination of Chemical Composition](#)

[E882 Guide for Accountability and Quality Control in the Chemical Analysis Laboratory](#)

¹ This test method is under the jurisdiction of ASTM Committee E01 on Analytical Chemistry for Metals, Ores, and Related Materials and is the direct responsibility of Subcommittee E01.02 on Ores, Concentrates, and Related Metallurgical Materials.

Current edition approved June 15, 2010. Published July 2010. Originally approved in 1965. Last previous edition approved in 2005 as E279 – 97 (2005). DOI: 10.1520/E0279-97R10.

² For referenced ASTM standards, visit the ASTM website, www.astm.org, or contact ASTM Customer Service at service@astm.org. For *Annual Book of ASTM Standards* volume information, refer to the standard's Document Summary page on the ASTM website.

3. Terminology

3.1 *Definitions*—For definitions of terms used in this test method, refer to Terminology [E135](#).

4. Summary of Test Method

4.1 The sample is placed in a tumbler drum which is rotated. The tumbled material is removed and screened to determine the degradation.

5. Significance and Use

5.1 This test method is a comparative method intended primarily to test materials for compliance with compositional specifications or for monitoring. It is assumed that all who use these procedures will be trained analysts capable of performing common laboratory procedures skillfully and safely. It is expected that work will be performed in a properly equipped laboratory and that proper waste disposal procedures will be followed. Appropriate quality control practices must be followed such as those described in Guide [E882](#).

5.2 This test method is used to monitor the feed to blast furnaces for process control.

6. Apparatus

6.1 *Tumbler Apparatus*, as shown in [Fig. 1](#), shall be a circular drum 914 mm (36 in.) in inside diameter and 457 mm (18 in.) in inside length constructed of steel plate at least 6.3 mm ($\frac{1}{4}$ in.) in thickness. The drum shall be replaced whenever the thickness of the plate is reduced by wear to 3.18 mm ($\frac{1}{8}$ in.) in any area. Two equally spaced steel angle lifters, 50.8 mm by 50.8 mm by 6.35 mm (2 in. by 2 in. by $\frac{1}{4}$ in.) shall be solidly attached longitudinally inside the drum by riveting in such a manner as to prevent accumulation of material between the lifter and drum. Preferably, one of the lifters shall be attached to the door for ease of sample removal. The lifters shall be fastened so that the attached legs point away from the direction of rotation, thus giving a clear unobstructed shelf for lifting the sample. The lifters shall be replaced when the wear is such that the shelf measures less than 47.6 mm ($1\frac{7}{8}$ in.). The door shall be so constructed as to fit into the drum to form a smooth inner surface and during the test shall be rigidly fastened to prevent any loss of the sample. The drum shall be rotated on stub axles about 38.1 mm ($1\frac{1}{2}$ in.) in diameter

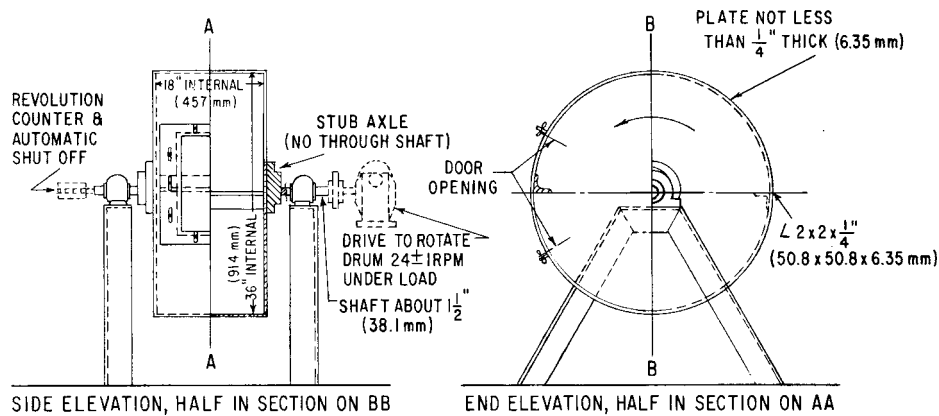

FIG. 1 Tumbler Test Apparatus

attached to the ends of the drum by means of flanges welded or bolted so as to provide smooth inner surfaces. The apparatus shall be fitted with a revolution counter and, preferably, with an automatic device to stop the drum after 200 revolutions.

6.2 *Sieves*—Square-mesh sieves having the following designations are needed: 2-in. (50-mm); 1½-in. (37.5-mm); ¾-in. (19.0-mm); ½-in. (12.5-mm); ⅜-in. (9.5-mm); ¼-in. (6.3-mm); and No. 30 (600-µm).

6.3 *Scales*—The scales used for weighing the sample shall be sensitive to 23 g (0.05 lb).

6.4 *Riffle*, having a 37.5-mm (1½-in.) opening.

7. Preparation of Sample

7.1 Sample Size:

7.1.1 *Pellets*—Use a 11.3-kg ± 0.23-kg (25-lb ± 0.5-lb) sample of 38.1-mm by 6.35-mm (1½ by ¼-in.) pellets dried to constant weight of 105 °C to 110 °C. Prepare by riffling the gross samples of pellets retained on the ¼-in. (6.3-mm) sieve to 11.3 kg (25 lb). The riffle should have 37.5-mm (1½-in.) openings in accordance with Practice E877.

NOTE 1—The gross sample collected shall be sufficient to obtain approximately 45.4 kg (100 lb) of pellets that will pass a 1½-in. (37.5-mm), and be retained on a ¼-in. (6.3-mm) square-mesh sieve. For pellets with more than 10 weight % larger than 12.7-mm (½-in.) the riffle opening should be three times larger than the largest single pellet to pass through the riffle.

7.1.2 *Sinter*—Use a 11.3-kg ± 0.23-kg (25-lb ± 0.5-lb) sample of 50.8-mm by 9.51-mm (2-in. by ⅜-in.) sinter. Prepare by taking proportionate weights of each size according to the screen analysis made by sieving the gross sample through 2-in. (50-mm), ¾-in. (19.0-mm), ½-in. (12.5-mm), and ⅜-in. (9.5-mm) sieves in accordance with Test Method E389.

NOTE 2—The gross sample collected shall be sufficient to obtain approximately 45.4 kg (100 lb) of sinter which will pass a 2-in. (50-mm), and be retained on ⅜-in. (9.5-mm) square-mesh sieve.

8. Procedure

8.1 Place the 11.3-kg (25-lb) sample into the tumbler drum. Rigidly fasten the door and rotate the drum at 24 rpm ± 1 rpm for a total of 200 revolutions. Then remove all of the material from the drum and hand sieve it on ¼-in. (6.3-mm) and No. 30 (600-µm) sieves. Separately weigh and record the amount of

sample retained on the ¼-in. (6.3-mm) sieve, the amount retained on the No. 30 (600-µm) sieve, and the amount passing the No. 30 (600-µm) sieve in accordance with Test Methods E276 and E389. Mechanical sieving may be used, provided it has been established that the method gives the same results as hand sieving.

9. Number of Tests

9.1 At least two tests shall be made on each pellet sample. If the differences between the values obtained exceed 0.4 units in the cumulative percentage over the ¼-in. (6.3-mm) or the No. 30 (600-µm) sieve, at least one further test shall be made and the mean value of all tests taken.

9.2 At least two tests shall be made on each sinter sample. If the differences between the values obtained exceed 2.0 units in the cumulative percentages over the ¼-in. (6.3-mm) or the No. 30 (600-µm) sieve, at least one further test shall be made and the mean value of all tests taken.

9.3 The total loss in weight in any one test may not exceed 0.7 weight % of the initial sample weight. If the total loss in weight exceeds 0.7 %, the test shall be rejected.

10. Report

10.1 The sieve analysis after tumbler test shall be reported to the nearest 0.1 % as the percent on the ¼-in. (6.3-mm) sieve and the percent passing the No. 30 (600-µm) sieve.

11. Precision and Bias

11.1 It is not possible to specify the precision of the procedure in this test method for abrasion resistance because of the variability of the material at the sampling location and the lack of precision data for the sieving standard used. It is important to retain this procedure as a standard due to the specifications of the mechanical controls in the procedure.

11.2 No information can be presented on the bias of the procedure in this test method for measuring abrasion resistance since no material having an accepted reference value is available.

12. Keywords

12.1 abrasion resistance; iron ore; pellets; sinter

 **E279 – 97 (Reapproved 2010)**

ASTM International takes no position respecting the validity of any patent rights asserted in connection with any item mentioned in this standard. Users of this standard are expressly advised that determination of the validity of any such patent rights, and the risk of infringement of such rights, are entirely their own responsibility.

This standard is subject to revision at any time by the responsible technical committee and must be reviewed every five years and if not revised, either reapproved or withdrawn. Your comments are invited either for revision of this standard or for additional standards and should be addressed to ASTM International Headquarters. Your comments will receive careful consideration at a meeting of the responsible technical committee, which you may attend. If you feel that your comments have not received a fair hearing you should make your views known to the ASTM Committee on Standards, at the address shown below.

This standard is copyrighted by ASTM International, 100 Barr Harbor Drive, PO Box C700, West Conshohocken, PA 19428-2959, United States. Individual reprints (single or multiple copies) of this standard may be obtained by contacting ASTM at the above address or at 610-832-9585 (phone), 610-832-9555 (fax), or service@astm.org (e-mail); or through the ASTM website (www.astm.org). Permission rights to photocopy the standard may also be secured from the ASTM website (www.astm.org/COPYRIGHT/).