



# Standard Guide for Design of Earthen Wall Building Systems<sup>1</sup>

This standard is issued under the fixed designation E2392/E2392M; the number immediately following the designation indicates the year of original adoption or, in the case of revision, the year of last revision. A number in parentheses indicates the year of last reapproval. A superscript epsilon ( $\epsilon$ ) indicates an editorial change since the last revision or reapproval.

## 1. Scope

1.1 This standard provides guidance for earthen building systems, also called earthen construction, and addresses both technical requirements and considerations for sustainable development. Earthen building systems include adobe, rammed earth, cob, cast earth, and other earthen building technologies used as structural and non-structural wall systems.

NOTE 1—Other earthen building systems not specifically described in these guidelines, as well as domed, vaulted, and arched earthen structures as are common in many areas, can also make use of these guidelines when consistent with successful local building traditions or engineering judgment.

1.1.1 There are many decisions in the design and construction of a building that can contribute to the maintenance of ecosystem components and functions for future generations. One such decision is the selection of products for use in the building. This guide addresses sustainability issues related to the use of earthen wall building systems.

1.1.2 The considerations for sustainable development relative to earthen wall building systems are categorized as follows: materials (product feedstock), manufacturing process, operational performance (product installed), and indoor environmental quality (IEQ).

1.1.3 The technical requirements for earthen building systems are categorized as follows: design criteria, structural and non-structural systems, and structural and non-structural components.

1.2 Provisions of this guide do not apply to materials and products used in architectural cast stone (see Specification C1364).

1.3 The values stated in either SI units or inch-pound units are to be regarded separately as standard. The values stated in each system may not be exact equivalents; therefore, each system shall be used independently of the other. Combining values from the two systems may result in non-conformance with the standard.

<sup>1</sup> This guide is under the jurisdiction of ASTM Committee E60 on Sustainability and is the direct responsibility of Subcommittee E60.01 on Buildings and Construction.

Current edition approved Sept. 1, 2016. Published September 2016. Originally approved in 2005. Last previous edition approved in 2010 as E2392/E2392M – 10<sup>ε</sup>. DOI: 10.1520/E2392\_E2392M-10R16.

1.4 *This standard does not purport to address all of the safety concerns, if any, associated with its use. It is the responsibility of the user of this standard to establish appropriate safety and health practices and determine the applicability of regulatory limitations prior to use.*

## 2. Referenced Documents

### 2.1 ASTM Standards:<sup>2</sup>

C1364 Specification for Architectural Cast Stone

D2487 Practice for Classification of Soils for Engineering Purposes (Unified Soil Classification System)

E631 Terminology of Building Constructions

E2114 Terminology for Sustainability Relative to the Performance of Buildings

### 2.2 ASCE Standards:<sup>3</sup>

ANSI/ASCE 7 Minimum Design Loads for Buildings and Other Structures

### 2.3 New Zealand Standards:<sup>4</sup>

NZS 4297:1998 Engineering Design of Earth Buildings, 1998

NZS 4298:1998 Materials and Workmanship for Earth Buildings, 1998

NZS 4299:1998 New Zealand Standard, Earth Buildings not requiring Specific Design, 1998 (including amendment #1, December 1999)

## 3. Terminology

### 3.1 Definitions:

3.1.1 For terms related to building construction, refer to Terminology E631.

3.1.2 For terms related to sustainability relative to the performance of buildings, refer to Terminology E2114. Some of these terms are reprinted here for ease of use.

3.1.3 *alternative agricultural products, n*—bio-based industrial products (non-food, non-feed) manufactured from agricultural materials and animal by-products.

<sup>2</sup> For referenced ASTM standards, visit the ASTM website, [www.astm.org](http://www.astm.org), or contact ASTM Customer Service at [service@astm.org](mailto:service@astm.org). For *Annual Book of ASTM Standards* volume information, refer to the standard's Document Summary page on the ASTM website.

<sup>3</sup> Available from American Society of Civil Engineers (ASCE), 1801 Alexander Bell Dr., Reston, VA 20191, <http://www.asce.org>.

<sup>4</sup> Available from Standards New Zealand, Ministry of Business, Innovation & Employment, 15 Stout Street, Wellington 6011, <http://www.standards.govt.nz>.

3.1.4 *biodegradable, adj*—capable of decomposing under natural conditions into elements found in nature.

3.1.5 *biodiversity, n*—the variability among living organisms from all sources including: terrestrial, marine and other aquatic ecosystems and the ecological complexes of which they are a part; this includes diversity within species, between species and of ecosystems.

3.1.6 *ecosystem, n*—a community of biological organisms and their physical environment, functioning together as an interdependent unit within a defined area.

3.1.6.1 *Discussion*—For the purposes of this definition, humans, animals, plants, and microorganisms are individually all considered biological organisms.

3.1.7 *embodied energy, n*—the energy used through the life cycle of a material or product to extract, refine, process, fabricate, transport, install, commission, utilize, maintain, remove, and ultimately recycle or dispose of the substances comprising the item.

3.1.7.1 *Discussion*—The total energy which a product may be said to “contain” including all energy used in, inter alia, growing, extracting, transporting and manufacturing. The embodied energy of a structure or system includes the embodied energy of its components plus the energy used in construction.

3.1.8 *indoor environmental quality, IEQ, n*—the condition or state of the indoor environment.

3.1.8.1 *Discussion*—Aspects of IEQ include but are not limited to characteristics of the thermal, air, luminous and acoustic environment. Primary areas of concern in considering the IEQ usually relate to the health, comfort and productivity of the occupants within the indoor environment, but may also relate to potential damage to property, such as sensitive equipment or artifacts.

3.1.9 *renewable resource, n*—a resource that is grown, naturally replenished, or cleansed, at a rate which exceeds depletion of the usable supply of that resource.

3.1.9.1 *Discussion*—A renewable resource can be exhausted if improperly managed. However, a renewable resource can last indefinitely with proper stewardship. Examples include: trees in forests, grasses in grasslands, and fertile soil.

3.1.10 *sustainability, n*—the maintenance of ecosystem components and functions for future generations.

3.1.11 *sustainable development, n*—development that meets the needs of the present without compromising the ability of future generations to meet their own needs.

3.1.12 *toxicity, n*—the property of a material, or combination of materials, to adversely affect organisms.

### 3.2 *Definitions of Terms Specific to This Standard:*

3.2.1 *adobe, n*—(1) (*building product*), unfired masonry units made of soil, water, and sometimes straw or other admixtures;

(2) (*product feedstock*), the soil/straw/admixtures mix that is used to make *adobe* (1), (here also called *earthen building mixtures* or *earthen material*);

(3) (*building product*), the earth plaster used for covering walls or ceilings, or both;

(4) (*structure*), the building that is built of *adobe* (1), (3); and (5) (*building design*), an architectural style of earthen construction (see also 3.2.9).

3.2.1.1 *Discussion*—The word itself comes from an Arabic word *atob*, which means muck or sticky glob or *atubah* “the brick.” In many other countries, the word “adobe” is meaningless, and it is more accurate to say “earthen-brick.” “Adobe architecture” also has different meanings in different places.

3.2.2 *asphalt emulsion, n*—a thick liquid made by combining by-products of crude oil distillation with water and proprietary surfactants.

3.2.3 *cast earth, n*—a construction system utilizing a slurry containing soil plus a chemical binder such as portland cement or calcined gypsum and water, which is sprayed against or poured into forms similar to those used for cast-in-place concrete; also called *poured earth*.

3.2.3.1 *Discussion*—In the sprayed system, modern shotcrete equipment is adapted to spray the wet earth mixture, which is usually stabilized earth.

3.2.4 *clay, n*—inorganic soil with particle sizes less than 0.002 mm [0.00008 in.] having the characteristics of high to very high dry strength and medium to high plasticity.

3.2.4.1 *Discussion*—This size definition for clay, along with those for silt, sand and gravel, is according to Practice D2487. Other standards in the world have slightly different size limitations.

3.2.5 *cob, n*—a construction system utilizing moist earthen material stacked without formwork and lightly tamped into place to form monolithic walls.

3.2.5.1 *Discussion*—Reinforcing is often provided with organic fibrous materials such as straw.

3.2.6 *earth, n*—granular material derived from rock, usually with air voids and often with organic content (humus) (also called *soil*).

3.2.7 *earth, stabilized, n*—earthen building mixtures to which admixtures are added during the manufacturing process to help limit water absorption, stabilize volume, increase strength, and increase durability (see also *stabilization*).

3.2.8 *earth, unstabilized, n*—earthen building mixtures that do not contain admixtures intended to help limit water absorption, stabilize volume, increase strength, and increase durability (see also *stabilization*).

3.2.9 *earthen construction, n*—construction in which walls and partitions are comprised primarily of earth.

3.2.9.1 *Discussion*—Roofs and other framing may be wholly or partly of wood or other materials. Common earthen construction systems go by many names, which sometimes connote minor variations. Some of those names are:

*adobe, or mud brick, earthen brick, banco, butabu, brique de terre*  
*cast earth, or poured earth, earthcrete, sprayed earth*  
*cob, or zabur, puddled mud, puddled earth*  
*extruded earth block*  
*pressed brick, or compressed earth brick/block (CEB)*  
*rammed earth, or pisé, tapial*  
*sod, or turf, fale and divet*  
*tire houses, also earth bags, earth tubes*  
*wattle and daub, or quincha, jacal, barjareque, nyumba yo mata*

3.2.10 *energy efficient, adj*—refers to a product that requires less energy to manufacture or uses less energy when operating in comparison with a benchmark for energy use, or both.

3.2.10.1 *Discussion*—For example, the product may meet a recognized benchmark, such as the EPA’s Energy Star Program standards.

3.2.11 *gravel, n*—inorganic soil with particle sizes greater than 4.75 mm [0.187 in.].

3.2.12 *horizon, n*—distinctive layer of in situ soil having uniform qualities of color, texture, organic material, and obliteration of original rock material.

3.2.12.1 *Discussion*—In *World Reference Base for Soil Resources*, by the Food and Agriculture Organization of the United Nations, seven master horizons are recognized – H, O, A, E, B, C, and R.

3.2.13 *loam, n*—soil with a high percentage of organic material, particles are predominately silt size but range from clay size to sand size.

3.2.13.1 *Discussion*—Loams are usually good agricultural soils due to their nutritional organic content and their ability to hold water. Loams should be avoided in earthen construction, as the organic content is subject to biological decay and volume change. Note that the word “loam” derives from the German “lehm.” In Europe, “loam” and “lehm” usually have an opposite meaning; that is, they connote earth with a very low organic content, ideal for building but not for agriculture.

3.2.14 *material (product feedstock), n*—refers to the substances that are required for the manufacture or fabrication, or both, of a building product.

3.2.14.1 *Discussion*—Material resources include raw materials and recycled content materials.

3.2.15 *moisture wicking*—the capillary uptake of water from foundation soil or precipitation.

3.2.15.1 *Discussion*—Moisture wicking can result in saturation of adobe with an accompanying decrease in strength and durability.

3.2.16 *operational performance, n*—refers to the functionality of a product during its service life.

3.2.16.1 *Discussion*—Specific measures of operational performance will vary depending upon the product. Aspects of operational performance include: structural strength, durability, energy efficiency, and water efficiency.

3.2.17 *poured earth, n*—see *cast earth*.

3.2.18 *pressed block, n*—a block (or brick, or the construction system using those blocks) that consists of earthen materials formed in a block mold by the mechanical compaction of lightly moistened earth into a dense mass (also called *compressed earth block, CEB*).

3.2.19 *rammed earth, n*—a construction system that consists of walls made from moist, sandy soil, or chemically stabilized soil, which is tamped into forms (mechanically stabilized).

3.2.20 *sand, n*—inorganic soil with particle sizes ranging from 0.75 to 4.75 mm [0.03 to 0.19 in.].

3.2.21 *silt, n*—inorganic soil with particle sizes ranging from 0.002 to 0.75 mm [0.00008 to 0.03 in.] having the characteristics of low dry strength, low plasticity, and little dilatancy.

3.2.22 *soil, n*—see *earth*,

3.2.23 *stabilization, n*—modification of soils to limit water absorption, stabilize volume, increase strength, and increase durability, or some combination of these.

3.2.23.1 *Discussion*—For the purposes of this guide, reference to “stabilization” or “stabilized” means chemical stabilization or chemically stabilized. Chemical stabilization is achieved by the intermixture of cement, lime, gypsum, asphalt emulsion, or other materials with the soil before emplacement, and curing as appropriate for the stabilizer and chemical reaction. Mechanical stabilization is achieved by compacting or compressing a plastic earth mixture, or containing earth in permanent forms such as bags.

3.2.24 *straw, n*—an agricultural waste product that is the dry stems of cereal grains, or sometimes native grasses, after the seed heads have been removed.

3.2.25 *straw-clay, n*—a construction system that consists of clay slip mixed with straw, of which straw makes up a high percentage by volume.

3.2.25.1 *Discussion*—Other fibers such as wood shavings or paper are sometimes used. This system is well suited for manufacturing blocks and in situ insulating wall panels.

## 4. Summary of Guide

4.1 This guide identifies the principles of sustainability associated with earthen building systems. Additionally, it outlines technical issues associated with earthen building systems, identifying those that are similar to construction that is commonly used in the marketplace.

4.2 This guide is intended for use in framing decisions for individual projects.

4.3 This guide is intended for use in development of standards and building codes for earthen building systems.

## 5. Significance and Use

5.1 *Historical Overview*—Earthen building systems have been used throughout the world for thousands of years. Adobe construction dates back to the walls of Jericho which was built around 8300 B.C. Many extant earthen structures have been functioning for hundreds of years. However, with the development of newer building materials, earthen building systems have fallen into disfavor in parts of the world where they were once commonly used. At the same time, earthen construction is experiencing a revival in the industrialized world, driven by a number of factors.

5.2 *Sustainability*—As world population continues to rise and people continue to address basic shelter requirements, it becomes increasingly necessary to promote construction techniques with less life cycle impact on the earth. Earthen building systems are one type of technique that may have a favorable life cycle impact.

**5.3 Building Code Impact**—Earthen building systems have historically not been engineered, but as of the late 20th Century it is for the first time in history possible to reliably apply rational structural design methods to earthen construction. A large number of earthen building codes, guidelines and standards have appeared around the world over the past few decades, based upon a considerable amount of research and field observations regarding the seismic, thermal and moisture durability performance of earthen structures. Some of those standards are:

Australian Earth Building Handbook  
California Historical Building Code  
Chinese Building Standards  
Ecuadorian Earthen Building Standards  
German Earthen Building Standards  
Indian Earthen Building Standards  
International Building Code / provisions for adobe construction  
New Mexico Earthen Building Materials Code  
New Zealand Earthen Building Standards  
Peruvian Earthen Building Standards

This guide draws from those documents and the global experience to date in providing guidance on earthen construction to engineers, building officials, and regulatory agencies.

**5.4 Audience**—There are two primary and sometimes overlapping markets for earthen construction and for this guide:

**5.4.1 Areas with Historical or Indigenous Earthen Building Traditions**—In places where earthen architecture is embedded in the culture, or there is little practical or economical access to other building systems, this guide can set a framework for increasing life safety and building durability.

**5.4.2 Areas with a Nascent or Reviving Interest in Earthen Architecture**—In places where earth is sometimes chosen over other options as the primary structural material, this guide provides a framework for codification and engineering design.

## **6. Considerations for Sustainable Development and Durability**

**6.1 Materials (Product Feedstock)**—Materials of earthen building systems include clay soil and inorganic or organic tempering materials. Silt, sand, and gravel are commonly used inorganic tempers and straw, hair, and chaff are commonly used organic tempers. Soils may be stabilized, using such materials as cement, asphalt emulsion, calcined gypsum or cactus juice, or may be unstabilized. Systems may be finished with plaster or left unfinished.

**6.1.1 Soil**—Soils for earthen building systems are a mixture of a binder (clay), and temper soils of silt, sand, and gravel. These mixtures may be naturally occurring local soils or engineered by mixing different soils. Sources for the soils include on-site horizons, by-products of sand and gravel quarrying, and alluvial deposits. Some clays are highly expansive (montmorillonites) or moderately expansive (illites) when wetted, and thus problematic for earthen construction. Ideally, a non-expansive kaolinite clay should be used. The intermixture of small amounts of lime, bitumen, or cement will negate the expansive properties of swelling clays, but by the same chemical mechanism negate the binding and other beneficial properties of the clay. Stabilizing binders should thus generally be used only when there is no other viable strategy for meeting the project requirements. Care should be taken to avoid adverse

affects on the capacity for food production when considering the use of loams and other soils that are suitable for agricultural purposes.

**6.1.2 Straw**—Straw, being dry and having no seed heads is more durable in earthen building systems than hay which contains seed heads. Straw is an agricultural waste product that is typically not used for productive end use; therefore, it is considered an alternative agricultural product and a renewable resource when used in earthen building systems.

**6.1.3 Plaster**—“Plaster” is a material applied to the exposed surfaces of earthen building systems to improve durability and modify appearance.

**6.1.3.1 Earth (or clay) Plaster**—Earth plaster is a mixture of clay, silt, sand, and water. Fibrous tempering materials are typically added.

**6.1.3.2 Cement Plaster**—Cement plaster is a mixture of cement, sand and water; the mixture may also include pozzolans, lime, pigments, glass fibers, and proprietary admixtures. Cement plaster, which is considerably less vapor-permeable than earthen plaster, can trap moisture, resulting in saturation and deterioration of unstabilized earth wall systems. For this reason, the use of cement plaster over unstabilized earth is strongly discouraged.

**6.1.3.3 Lime Plaster**—Lime plaster is a mixture of hydrated lime and sand that is much more compatible with unstabilized earth than cement plaster in terms of vapor permeability, coefficient of temperature change, and stiffness. Lime plaster has a long and successful history of use over indigenous earthen building systems in various cultures. Successful application of lime plaster over unstabilized earth does require some manner of mechanical locking, such as by scoring the earth surface, and careful application of the lime in progressive layers.

### **6.2 Manufacturing Process:**

**6.2.1 Manufacturing**—The manufacturing process of creating a building product includes not only the process to produce manufacturing, but also fabrication and distribution procedures. The manufacture of unstabilized earthen building materials is substantially more energy efficient per unit volume than the manufacture of fired-clay masonry like brick, terra-cotta or structural clay tile, or the manufacture of cement-based systems like concrete masonry, precast concrete, or cast-in-place concrete. Stabilized earthen materials that use Portland cement, lime, asphalt emulsion or calcined gypsum are less energy efficient to manufacture per unit volume than similar unstabilized materials, but are generally more energy efficient to manufacture than cement-based concrete materials.

**6.2.2 Fabrication**—In the fabrication of earthen construction a clay binder is tempered with inorganic or organic materials, or both, to reduce shrinkage and cracking, and to increase strength and workability. Soils may be unstabilized or may be stabilized. Stabilizing is done to increase durability and strength. Placement of adobe and pressed-block systems is similar to the placement of fired-clay and concrete masonry units systems in that manufactured units are hand stacked upon one another to produce structures. Where the fabrication of these systems differs is in the mortar used to bond the

manufactured units, or the firing of the units, or both. Fired-clay and concrete masonry systems use mortars containing Portland cement, proprietary masonry cements, and mortar cements, and lime putty which use substantially more energy in their manufacturing processes than unstabilised earthen building mortars and, to a lesser degree, stabilized earthen building mortars. Fabrication of rammed earth is similar to the fabrication of cast-in-place concrete systems in that formwork is required. Formwork is usually temporary wood, steel, fiberglass or earth construction built to give the desired shape and size to the completed structure. The formwork is removed before full curing of the material and can be reused or recycled depending upon the material used. Where the systems differ is in the amount of labor required to place the materials in the formwork. Cast-in-place concrete, which is continuously poured into place until the desired height or thickness is obtained, requires less onsite labor than rammed earth, which is placed into the form in short layers called lifts and compacted after each lift. Fabrication by the cob method involves placement of the material directly into its final position without using forms.

**6.2.2.1 Energy Use**—Because of the additional steps and energy input required for transport and fabrication, fired-clay, concrete masonry, steel, and most wood systems use more embodied energy in their manufacturing processes than unstabilized earthen building systems. Stabilized earthen building systems use slightly more embodied energy because of the use of small amounts of cement or other admixtures in their fabrication. Embodied energy involved in the formwork is equal for all methods requiring temporary formwork.

**6.2.3 Distribution Procedures**—Distribution procedures for earthen building systems range from on-site extraction, manufacturing and fabrication of individual buildings by their owners to regional multi-party systems involving off-site quarries, masonry manufacturers, and building contractors.

**6.3 Operational Performance (Product Installed)**—The need for stabilization will vary from project to project and professional judgment is required.

**6.3.1 Discussion**—There are historic, multi-story apartment buildings made with unstabilized earth that have provided hundreds of years of useful service (for example Taos Pueblo, United States, and Shibam, Yemen), demonstrating that unstabilized earthen construction can be much more durable than is generally thought. In order to minimize financial costs to building owners, complication and waste during construction, and pollution costs to the ecosystem, stabilization by cement, lime or gypsum should only be used where other strength and durability measures (such as roof overhangs, reinforcing, renewable plasters, or thicker walls) cannot achieve the same strength and durability goals.

**6.3.2 Durability**—Moisture can degrade unstabilized earthen building systems. Therefore, they should be protected with some combination of foundations raised above the level of rain splash or potential flood, protective coating such as renewable earthen or lime plaster, or overhangs of sufficient size to deflect wind-driven rain. Various factors may affect durability and rate of erosion; therefore, specific site and climate conditions should be carefully evaluated. Demolished,

unstabilized adobe can disintegrate and return to the soil without negative impact on the ecosystem. Materials used to stabilize earthen building systems, such as asphalt emulsion and cement, can greatly increase strength and durability, but alter soils and their suitability for agricultural uses.

**6.3.2.1 Standard construction materials tests** such as dry compressive strength, wet compressive strength, modulus of rupture, percent absorption, moisture content, spray and drip erosion, field density, and dry density can be used to assess the probable durability of earthen building systems. In many areas with a tradition of earthen construction, some criteria, based on these tests but modified to reflect the unique characteristics of earthen materials, are already in place for determining moisture susceptibility and load resistance.

**6.3.3 Energy Efficiency**—Earthen building systems provide thermal storage capacity (specific heat) but little insulation (R-value). In climates where the desired indoor temperature is between the maximum and minimum daily outdoor temperatures, exterior walls of earthen building systems can dampen thermal transfer and help stabilize indoor temperatures. In climates where both the maximum and minimum daily temperatures are above or below the desired indoor temperatures for several consecutive days, weeks or months, exterior walls of earthen building systems may reduce thermal comfort by increasing conducted heat. In these climates, earthen building systems can improve energy efficiency only if insulation is installed to isolate the earthen construction from outdoor temperature changes, or limiting earthen construction to interior walls.

**6.4 Indoor Environmental Quality (IEQ)**—IEQ for earthen building systems is generally good. Possible sources of indoor pollution from earthen construction are VOC outgassing associated with asphalt stabilization and dusting from unstabilized systems.

## 7. Technical Requirements

### 7.1 Structural Engineering Design:

**7.1.1 Engineered design of unstabilized earthen walls** can make use these New Zealand Standards: NZS 4297:1998, NZS 4298:1998, and NZS 4299:1998.

**7.1.2 Stabilized earth, especially cement-stabilized earth,** belongs more under the purview of existing standards for concrete and concrete masonry construction (see also **7.1.6**).

**7.1.2.1 Discussion**—Cement-stabilized earth, especially pressed brick and rammed earth which are mechanically compacted, often achieves compressive strengths comparable to ordinary concrete. Engineers in many parts of the world have used locally-accepted design procedures for concrete and concrete masonry in designing cement-stabilized earthen structures.

**7.1.3 Unstabilized earth** can lose much of its structural strength when moist or wet. Thus, earthen construction should not be used for below-grade applications such as foundation or basement walls, or retaining walls. Also, in designing earth walls or other structures exposed to weather, provisions of **6.3.2 (Durability)** should be rigorously followed, or else reduced effective section properties used based on possible depth of wetting or erosion.

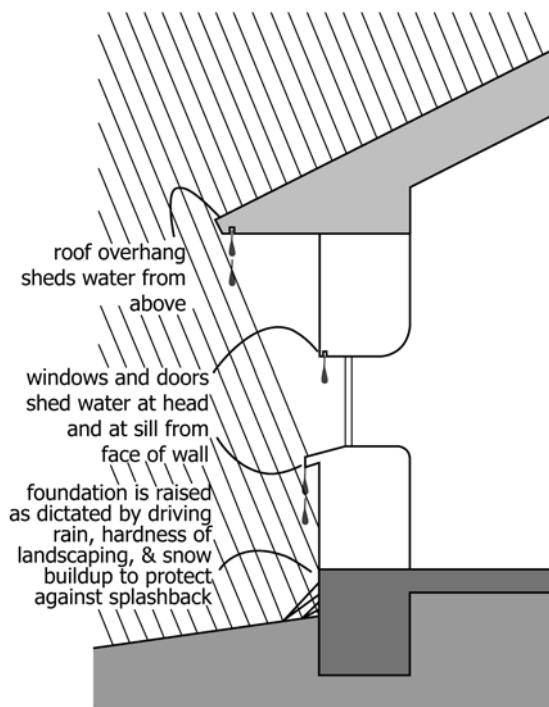

NOTE 1—Unstabilized earthen walls should be protected by every means possible from rain, driving or splashing rain, snow, and other sources of moisture and erosion.

FIG. 1 Moisture Protection Strategies

7.1.3.1 *Discussion*—A common problem with earthen walls is basal erosion: a horizontal cavity that develops at the exterior base of walls, where sheeting rain coming down the face of the wall combines with rain splash to accelerate erosion. This effect can be countered with larger roof overhangs, a stone plinth along the base of the wall, and renewed plaster coatings as needed, or some combination of these.

7.1.4 Lintels over wall openings should be designed for the weight of the wall above plus any tributary roof load, and should in all cases have at least 300 mm [12 in.] of bearing on the earthen wall at both sides of the opening.

7.1.5 Mortars should be as nearly as possible the same material as the masonry in terms of strength, stiffness, and vapor permeability. Unstabilized earthen mortars should not be used on the exterior of cement-stabilized or stone masonry, and cement-based mortars should not be used with unstabilized earthen masonry. In all cases, mortar joints should be kept as thin as practicable; the thinner the mortar joints, the stronger the wall.

7.1.6 Design of cement-stabilized rammed earth walls with steel reinforcing bars can make use of established structural design methods for reinforced concrete, except that minimum reinforcing steel requirements can, and usually must, be relaxed as needed to allow access for thorough and dense ramming of the material within the formwork. Material strengths and other key properties should be reliably established.

7.1.7 Where engineering design is not feasible or available, earthen structures can be constructed according to empirical guidelines as illustrated and defined in Appendix X1 to this guide. Detailing provisions of Appendix X1 apply to all earthen structures.

7.1.7.1 *Discussion*—The purpose of Appendix X1 is to provide guidance for safe construction in those areas without easy access to engineering services, nor economical access to industrial building materials such as cement and steel reinforcing.

## 7.2 Design Criteria:

7.2.1 Earthen buildings, structures, and parts thereof should be designed and constructed as much as practicable in accordance with internationally recognized design standards. Design live, wind, and seismic loads can be based on local knowledge or make use of known references such as the International Building Code or American National Standards Institute/American Society of Civil Engineers document ANSI/ASCE 7. Engineered design can make use of strength (load and resistance factor) design, allowable stress design, or empirical design.

7.2.2 *Seismic Design*—Seismic design requirements for life safety vary greatly with the local degree of seismic risk, but should in all cases provide structural continuity, out of plane stability, and containment. Detailing provisions of Appendix X1 should be applied to all earthen structures. Relevant provisions of ANSI/ASCE 7 should be used to estimate seismic demand loads on elements, connections and reinforcing shown in Appendix X1, using static or dynamic procedures for unreinforced masonry structures.

7.2.2.1 *Discussion*—Seismic design of earthen buildings (or reinforcement of existing earthen buildings) has evolved enormously with the testing and research of the past few decades. Some tentative modeling for static or dynamic force procedures has emerged, but prevailing engineering thought is to emphasize global and local stability rather than traditional (and much less reliable) stress analysis. Seismic forces that any particular structure must withstand can only be approximated, but extensive field observations and shake table tests have shown where a structure should be reinforced and interconnected so as to remain intact and stable under seismic shaking.

7.2.3 *Flood Design*—Unstabilized earthen walls are not considered suitable for flood prone areas unless raised by foundation or durable plinth above the level of potential flooding.

## 8. Keywords

8.1 adobe; alternative agricultural products; alternative building materials; cob; compressed earth brick; earthen architecture; earthen construction; energy efficiency; indoor environmental quality (IEQ); natural building materials; rammed earth construction; sustainability; sustainable development; thermal mass

**APPENDIX**
**(Nonmandatory Information)**
**X1. EMPIRICAL DESIGN AND MINIMUM DETAILING REQUIREMENTS FOR EARTHEN STRUCTURES**
**X1.1 Scope**

X1.1.1 Provisions of **Appendix X1** should be used where engineered design of structures is not available or feasible. Provisions of **Appendix X1** cannot be reliably applied to structures of more than one story in areas of medium or high seismic risk. In the absence of specific guidance or definition from a local authority, seismic risk for a building project can be defined as a greater than 10 % chance of exceedance in a fifty year period as follows:

<i>Low risk</i>	Mercalli intensity scale no higher than IV
<i>Medium risk</i>	Mercalli intensity scale between IV and VIII
<i>High risk</i>	Mercalli intensity scale of VIII or higher

Ground motion predictions can be based on “An Atlas of ShakeMaps for Selected Global Earthquakes.”<sup>5</sup>

X1.1.2 *Discussion*—Many historical and modernized systems of building with unstabilized earth exist around the globe, and comprise the housing for a large percentage of humanity. In many cases, multiple examples can be found of extant structures with many centuries of useful service life, none of which have been designed by engineers. The durability, utility, and appeal of earthen construction is thus established, and historical systems in particular express designs generally well adapted to local climate and conditions. The exception here is in regards to seismic durability, as few cultures have evolved effective means of reinforcing earthen buildings against earthquake damage and collapse. Thus, **Appendix X1** is concerned primarily with providing guidance for basic seismic reinforcing as can be of use to builders in areas of medium or high seismic risk, and draws on successful experience of the past decades with seismic design and retrofit strategies that have been developed by engineers worldwide. Seismic design of buildings is substantially more complex than might be inferred from these guidelines, but even the simplified provisions illustrated in **Appendix X1** would be of far greater utility in protecting life than the absence of any guidelines at all.

X1.1.3 For purposes of **Appendix X1**, seismic risk is considered to be low, medium or high based on local experience, prevailing building codes or standards, or the assessment of a professional geologist or engineer.

**X1.2 Material**

X1.2.1 *Earthen Building Mixture*—Earthen materials to be used for construction, and trial earthen wall components or systems, should be tested for adequate strength and durability for the project. It should be noted that the average rural homebuilder will generally not have access to multiple soil types, nor to precise means of testing soils. Some of many well-known field tests for various properties are described in

**Appendix X1** and can be used to find approximate values for use in design and construction.

X1.2.1.1 *Mixing*—Experience has shown that the time and quality of mixing earth with water can greatly affect strength and durability of the cured product; too little or too much mixing gives less than optimal properties, and the optimal mix time should be established for each earth mixture, building system, and project.

X1.2.1.2 *Brick Tests*—One effective manner of assessing the suitability of the soil mixture is to make several trial bricks using various combinations of the available soils, and cure these as much as possible as they will be cured in situ. At the end of the curing period bricks should be able to be handled without crumbling or being easily damaged; and not have developed any crack longer than 75 mm [3 in.], wider than 3 mm [ $\frac{1}{8}$  in.] or deeper, irrespective of length or width, than 10 mm [ $\frac{1}{16}$  in.]. This brick test is intended for adobe or pressed block construction, but can also be useful in evaluating soils for rammed earth or cob construction.

X1.2.2 *Reinforcing*—Tensile reinforcing for earthen walls or bond beams should be at least strong enough to support the weight of a grown man (100 kg [220 lb]) without excessive deformation; mortar reinforcing need only be half as strong (50 kg [110 lb]). All reinforcing should be lapped at splices enough to maintain continuity of strength. Special care should be taken to protect organic fiber reinforcing from moisture. See provisions of **6.3.2** (Durability) and **7.1.2**.

**X1.3 Workmanship**

X1.3.1 *Earthen Building Construction*—Mixture of earthen material, curing of bricks, and assembly of walls should be consistent with widespread and successful local building tradition, wherever possible. “Successful” buildings are ones that have lasted for at least three generations without substantial maintenance or repair. In areas of medium or high seismic risk, traditional systems should be modified and reinforced consistent with **Appendix X1**.

**X1.4 Design**

X1.4.1 *Low Seismic Risk Areas*—Earthen buildings in areas of low seismic risk usually need to only comply with provisions of this guide, and Sections **X1.2** and **X1.3** of **Appendix X1**, but not **X1.4.2 – X1.4.7** except as may be needed to restrain roofs from wind uplift. See **X1.1.1** for definitions of seismic risk.

X1.4.2 *Medium or High Seismic Risk Areas*—Earthen buildings in areas of medium or high seismic risk should comply with all provisions of **Appendix X1** (see **X1.1.1** for definitions of seismic risk).

X1.4.3 *Provide Structural Continuity*—Provide tensile reinforcing across known or anticipated cracks, and especially around tops of walls.

<sup>5</sup> “An Atlas of ShakeMaps for Selected Global Earthquakes,” published by the U.S. Geological Survey, <http://pubs.usgs.gov/of/2008/1236>.

X1.4.3.1 *Top of wall reinforcing* is the most important single seismic reinforcing measure, and can be achieved with a bond (or *tie* or *collar* or *ring*) beam firmly anchored to both the top of wall and to the roof structure. Alternatively, existing buildings can be retrofit with a tension reinforcing band wrapped around the wall tops, anchored through the wall and encased in plaster. A bond beam should have sufficient flexibility to maintain ductile strength with out-of-plane deflections of up to 25 percent thickness of the earthen wall thickness.

X1.4.3.2 *Wall cracking* can be reduced and constrained with vertical or horizontal reinforcing, or both.

X1.4.4 *Out-of-Plane Stability*—Provide anchorage at wall tops and bracing, or both, and protection against basal erosion, as needed to resist out-of-plane wall weakening and failure at likely crack locations. The preferred method of maintaining out-of-plane stability is to vertically reinforce the walls and firmly restrain the wall tops with a strong, well-connected bond beam in accordance with X1.4.3. Another strategy is to limit the wall geometry in either or both of two ways:

X1.4.4.1 *Limit horizontal wall length* between cross walls.

X1.4.4.2 *Limit Wall Height-to-Thickness Ratio*—Stout walls are more stable and durable than thin walls; in lieu of (or in combination with) the provisions of X1.4.4.1, limit the wall height to eight times its thickness (medium seismic risk), and no more than six times the wall thickness (high seismic risk).

X1.4.5 *Containment*—Provide diffused reinforcing, such as external mesh or mortar joint reinforcing, that limits cracking and the size of pieces that might dislodge during severe shaking, especially anything overhead. Complete containment requires completely covering both inside and outside of walls with mesh that is then tied together through the wall thickness. Partial containment, or complete mortar joint reinforcing, has been shown by test and actual earthquake experiences to be adequate for one-story structures; essential locations for diffuse reinforcing, in descending order of importance, are: around tops of walls, vertically at principal corners, and around door and window openings. (See Fig. X1.4 and Fig. X1.5.)

X1.4.6 *Other Seismic Provisions:*

X1.4.6.1 *Roof Construction*—Roofs and any other supported structure should be kept as lightweight as possible, and be securely fastened to the wall tops. Earthen and heavy tile roofs are discouraged in high seismic risk areas.

X1.4.6.2 *Wall Layout*—The plan layout of walls should be robust—as regular and symmetrical as practicable. Walls should be firmly interconnected across intersections to prevent separation during seismic shaking.

X1.4.6.3 *Wall Openings*—For unreinforced earthen construction:

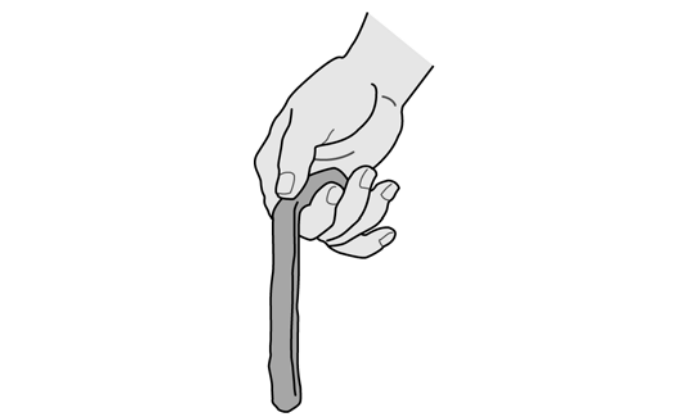

NOTE 1—A wet mass of soil is worked in the hand so as to extrude a ribbon of damp soil about the size of a finger. The ribbon should be able to hang from the hand without breaking for at least the same length as the hand. This test will establish plasticity and cohesion of the earth mixture, but not the strength or durability of the cured earthen material.

**FIG. X1.1 Ribbon Test**

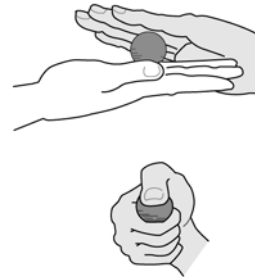

NOTE 1—A wet mass of soil is rolled in the hands so as to make a ball of approximately 2 cm [ $\frac{3}{4}$  in.] diameter. Several balls of the same mixture and moisture level are made and set aside to dry out of direct sun. After complete drying, none of the balls should be breakable between the thumb and fingers of one hand.

**FIG. X1.2 Ball Test**

- (1) Limit total wall openings to one-third of the total wall length,
- (2) Limit opening size to 1.2 m [4 ft], and
- (3) Provide wall lengths of at least 1.2 m [4 ft] between openings.

X1.4.7 An array of reinforcing and seismic mechanical stabilization strategies is presented above, but it may not be necessary to implement all of them. The designer/builder should select the most practical combination of these strategies that will provide structural continuity, out of plane stability, and containment.



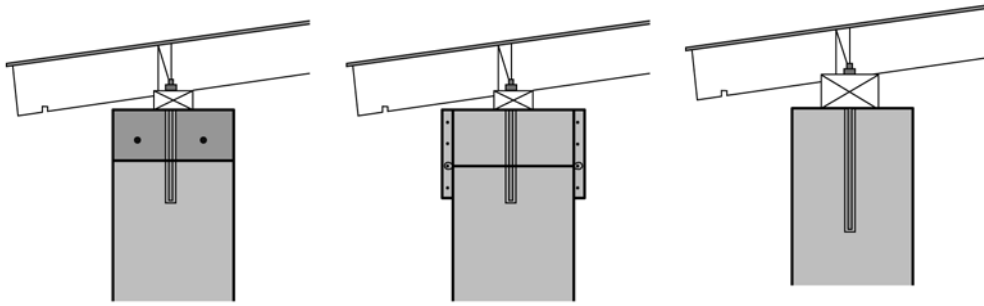

NOTE 1—The bond beam should transfer seismic loads between the roof structure and the wall (left: reinforced concrete bond beam; center: reinforced band beam for existing construction; right: heavy timber with frequent anchorage extending down into the wall by a depth at least equal to the thickness of the wall). Anchors between the bond beam and the wall should be spaced at no more than six times the wall thickness (medium seismic risk), and no more than three times the wall thickness (high seismic risk). Three generic types are pictured, but many similar or hybrid configurations can also work.

**FIG. X1.3 Bond (or Band) Beams to Stabilize Tops of Walls**

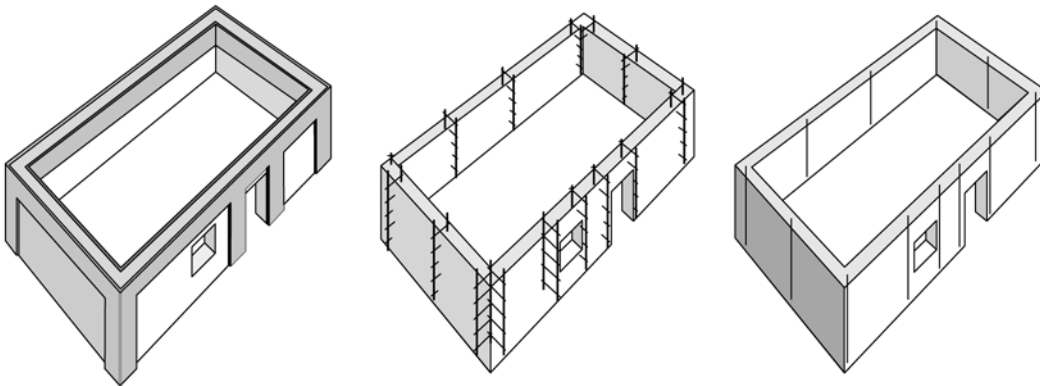

NOTE 1—Left: mesh banding tied through the wall; center: vertical reinforcing tied through the wall; right: internal vertical reinforcing in grouted cavities (requires hollow cavity masonry). In all cases, reinforcing should be installed at corners and principal openings and at intermediate locations so that vertical reinforcing is spaced no farther apart than the height of the wall. Spacing should be decreased with higher seismic risk. Three generic types are pictured, but many similar or hybrid configurations can also work.

**FIG. X1.4 Vertical Reinforcing for Crack Control**

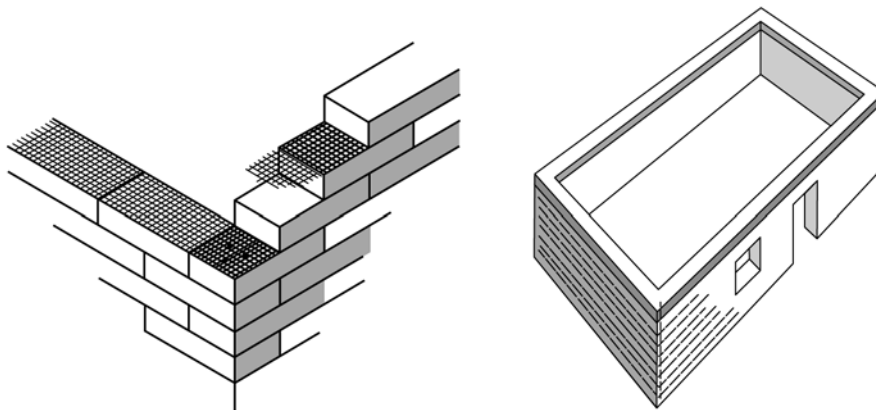

NOTE 1—Horizontal reinforcing can be external horizontal mesh banding (not pictured) tied through the wall, or thin reinforcing laid in mortar joints and secured to walls at corners. Spacing of reinforcing should be decreased with higher seismic risk.

**FIG. X1.5 Horizontal Reinforcing For Crack Control**

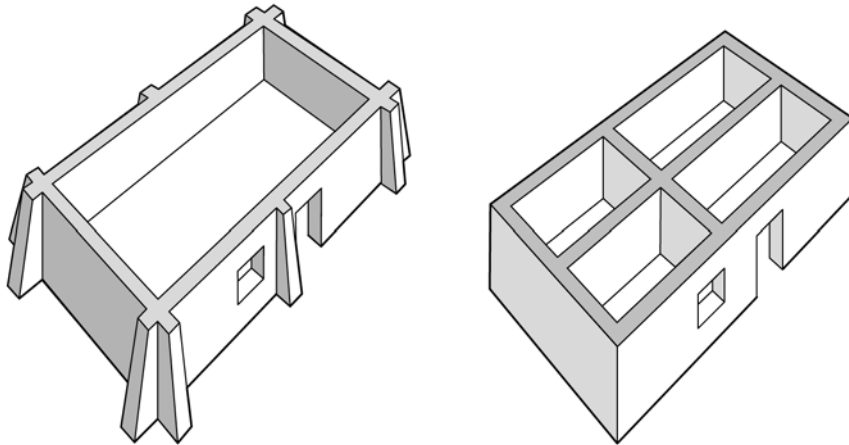

NOTE 1—Exterior pilasters (left) should be built at corners and intermediate locations, with protective cover from the roof and support at the foundation. Pilasters can be sloped as shown or vertical, but should project from the face of the wall by a distance at least as great as the wall thickness. Alternatively, the unbraced length of a wall between interior cross walls should be limited (right). In either case, bracing elements should be of the same construction as the wall, interlocked with the wall, not be farther apart than 15 times the wall thickness (medium seismic risk), and no more than 10 times the wall thickness (high seismic risk).

**FIG. X1.6 Wall Pilasters or Wall Density for Out-of-Plane Stability**

*ASTM International takes no position respecting the validity of any patent rights asserted in connection with any item mentioned in this standard. Users of this standard are expressly advised that determination of the validity of any such patent rights, and the risk of infringement of such rights, are entirely their own responsibility.*

*This standard is subject to revision at any time by the responsible technical committee and must be reviewed every five years and if not revised, either reapproved or withdrawn. Your comments are invited either for revision of this standard or for additional standards and should be addressed to ASTM International Headquarters. Your comments will receive careful consideration at a meeting of the responsible technical committee, which you may attend. If you feel that your comments have not received a fair hearing you should make your views known to the ASTM Committee on Standards, at the address shown below.*

*This standard is copyrighted by ASTM International, 100 Barr Harbor Drive, PO Box C700, West Conshohocken, PA 19428-2959, United States. Individual reprints (single or multiple copies) of this standard may be obtained by contacting ASTM at the above address or at 610-832-9585 (phone), 610-832-9555 (fax), or service@astm.org (e-mail); or through the ASTM website (www.astm.org). Permission rights to photocopy the standard may also be secured from the Copyright Clearance Center, 222 Rosewood Drive, Danvers, MA 01923, Tel: (978) 646-2600; http://www.copyright.com/*