



Standard Specification for Laboratory Glass Microvolumetric Vessels (Volumetric Flasks and Centrifuge Tubes)¹

This standard is issued under the fixed designation E237; the number immediately following the designation indicates the year of original adoption or, in the case of revision, the year of last revision. A number in parentheses indicates the year of last reapproval. A superscript epsilon (ϵ) indicates an editorial change since the last revision or reapproval.

1. Scope

1.1 This specification covers volumetric flasks and four types of centrifuge tubes, widely used in microchemistry.

NOTE 1—Specifications for several items listed below were developed by the Committee on Microchemical Apparatus, Division of Analytical Chemistry, American Chemical Society.²

1.2 Product with a stated capacity not listed in this standard may be specified Class A tolerance when product conforms to the tolerance range of the next smaller volumetric standard product listed in [Table 1](#).

2. Referenced Documents

2.1 *ASTM Standards*:³

[E438 Specification for Glasses in Laboratory Apparatus](#)

[E542 Practice for Calibration of Laboratory Volumetric Apparatus](#)

[E671 Specification for Maximum Permissible Thermal Residual Stress in Annealed Glass Laboratory Apparatus](#)

[E694 Specification for Laboratory Glass Volumetric Apparatus](#)

[E920 Specification for Commercially Packaged Laboratory Apparatus](#)

[E921 Specification for Export Packaged Laboratory Apparatus](#)

[E1133 Practice for Performance Testing of Packaged Laboratory Apparatus for United States Government Procurements](#)

¹ This specification is under the jurisdiction of ASTM Committee E41 on Laboratory Apparatus and is the direct responsibility of Subcommittee E41.01 on Apparatus.

Current edition approved Nov. 1, 2012. Published November 2012. Originally approved in 1964. Last previous edition approved in 2007 as E237 – 02(2007). DOI: 10.1520/E0237-02R12.

² Committee on Microchemical Apparatus, Division of Analytical Chemistry, American Chemical Society, "Report on Recommended Specifications for Microchemical Apparatus. Volumetric Glassware: Flasks, Pipets, and Centrifuge Tubes," *Analytical Chemistry*, Vol 28, 1956, p. 1993.

³ For referenced ASTM standards, visit the ASTM website, www.astm.org, or contact ASTM Customer Service at service@astm.org. For *Annual Book of ASTM Standards* volume information, refer to the standard's Document Summary page on the ASTM website.

[E1157 Specification for Sampling and Testing of Reusable Laboratory Glassware](#)

3. Volumetric Flasks

3.1 The volumetric flasks shall be of either Style I or Style II of [Fig. 1](#) and shall conform to the requirements of [Fig. 1](#) and [Table 1](#). Each flask shall be marked with the symbol "TC" (or "IN"), the capacity, "20°C", and a 16 mm² marking area. (All in an optional location on the flask.)

4. Centrifuge Tubes

4.1 Centrifuge tubes of four types shall conform to the requirements prescribed in [Tables 2-4](#) and [Figs. 2-5](#). The types shown fit into the metal shields supplied with commercially available centrifuges. Removal of the glass stoppers from the centrifuge tubes shown in [Fig. 3](#) and [Fig. 4](#) is advisable before centrifugation. The four types of centrifuge tubes specified are as follows:

4.1.1 Conical bottom, plain ([Fig. 2](#)).

4.1.2 Conical bottom, stoppered ([Fig. 3](#)).

4.1.3 Conical bottom, stoppered and graduated ([Fig. 4](#)).

4.1.4 Cylindrical bottom, plain ([Fig. 5](#)).

5. Sampling and Testing

5.1 Refer to Specification [E1157](#).

6. Calibration

6.1 Flasks and graduated tubes shall be calibrated in accordance with Practice [E542](#) and conform to applicable requirements of Specification [E694](#). Glass shall be Type I, Class A of Specification [E438](#) and annealing shall be in accordance with Specification [E671](#).

7. Packaging

7.1 Select from Specification [E920](#), Specification [E921](#), or Practice [E1133](#).

8. Keywords

8.1 glass, laboratory; microvolumetric; vessels

TABLE 1 Volumetric Flask (see Fig. 1)

Style	Capacity, mL	Class A/ Tolerance, ± mL	A, ID, max/mm	B, ID, ref/mm	C, max/mm	D, max/mm	Stopper No.
I	1	0.010	5.3	8.25	70	100	8
II	1	0.010	5.3	—	95	125	8
I	2	0.015	6.4	10.75	70	100	8
I	3	0.015	6.4	13.50	72	100	8
I	4	0.020	7.3	14.00	75	100	8
I	5	0.020	7.3	15.75	75	100	8
I	10	0.020	8.25	18.00	110	135	9
I	25	0.030	8.7	26.00	140	165	9

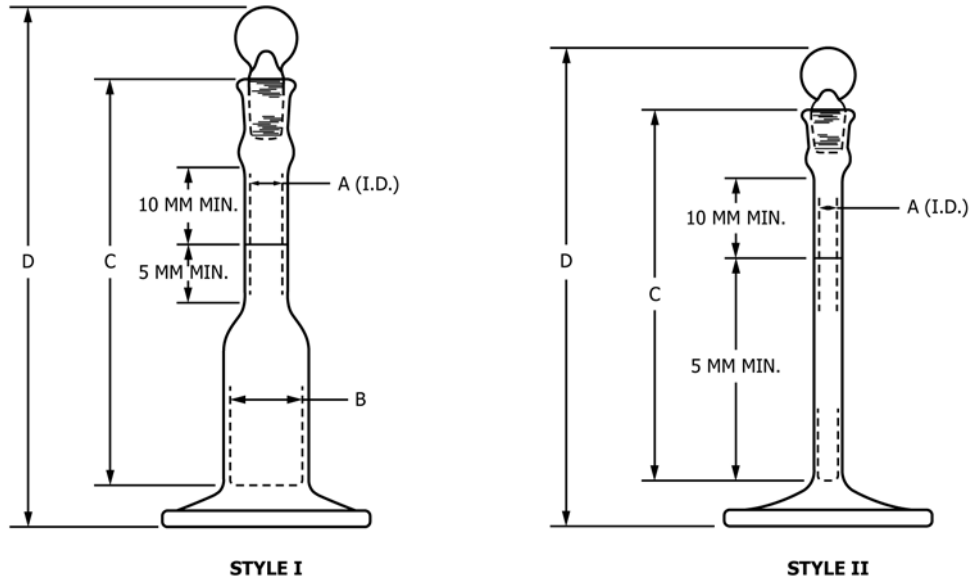

NOTE 1—The shape of the base may be either round or hexagonal

FIG. 1 Volumetric Flasks (see Table 1)

TABLE 2 Centrifuge Tubes, Conical Bottom, Plain (see Fig. 2)

Nominal Capacity, mL	A, Height, mm	B, OD Cylindrical Portion, mm	C, OD Top Finish, mm	D, Length of Taper, mm	E, OD at Bottom, mm
0.5	58 ± 2	6.0 ± 0.25	13.0 ± 1.0	30 ± 2	3.5 ± 0.5
1	61 ± 2	8.25 ± 0.25	13.0 ± 1.0	30 ± 2	3.5 ± 0.5
2	66 ± 2	10.75 ± 0.25	13.5 ± 1.0	30 ± 2	4.0 ± 0.5
3	74 ± 2	10.75 ± 0.25	13.5 ± 1.0	30 ± 2	4.0 ± 0.5
5	101 ± 2	13.00 ± 0.50	16.25 ± 0.75	40 ± 2	4.0 ± 0.5

TABLE 3 Centrifuge Tubes, Conical Bottom, Stoppered (see Fig. 3)

Nominal Capacity, mL	A, Height, mm	B, OD Cylindrical Portion, mm	C, OD Top Finish, mm	D, Length of Taper, mm	E, OD at Bottom, mm	F, Stopper No.
0.5	66 ± 2	6.0 ± 0.25	13.0 ± 1.0	30 ± 2	3.5 ± 0.5	detail G
1	69 ± 2	8.25 ± 0.25	13.0 ± 1.0	30 ± 2	3.5 ± 0.5	detail H
2	80 ± 2	10.75 ± 0.25	13.5 ± 1.0	30 ± 2	4.0 ± 0.5	9
3	88 ± 2	10.75 ± 0.25	13.5 ± 1.0	30 ± 2	4.0 ± 0.5	9
5	115 ± 2	13.0 ± 0.50	13.5 ± 1.0	40 ± 2	4.0 ± 0.5	9

TABLE 4 Volumetric Tolerances of Centrifuge Tube, Conical Bottom, Stoppered and Graduated, mL

At 0.1	±0.01
At 0.2	±0.02
At 0.3	±0.03
At 0.4	±0.05
Above 0.4	±0.075

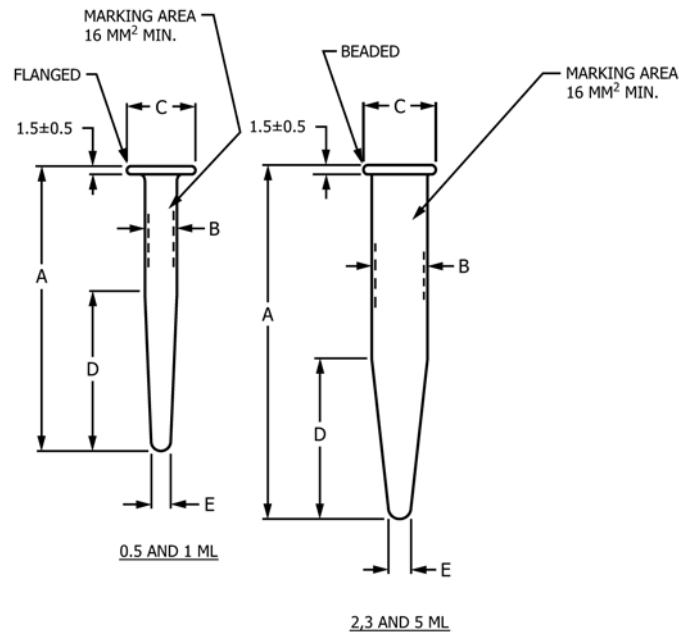

NOTE 1—All dimensions are in millimetres.

NOTE 2—Wall thickness of all sizes shall be approximately 1 mm.

NOTE 3—Interior of bottoms shall be rounded.

FIG. 2 Centrifuge Tubes, Conical Bottom, Plain (see Table 2)

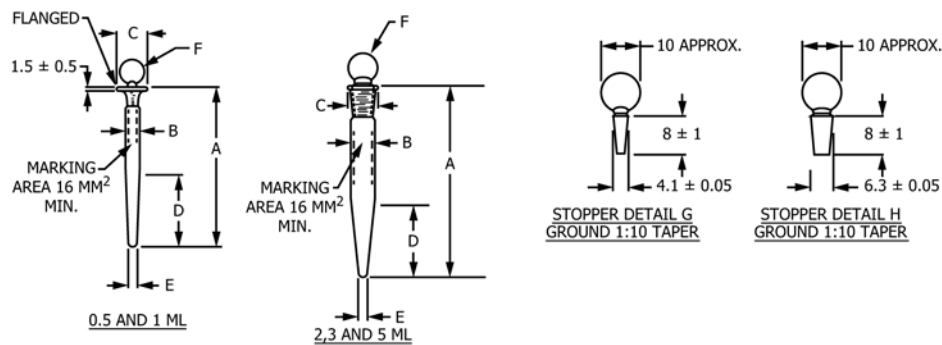

NOTE 1—All dimensions are in millimetres.

NOTE 2—Wall thickness of all sizes shall be approximately 1 mm.

NOTE 3—Interior of bottoms shall be rounded.

FIG. 3 Centrifuge Tubes, Conical Bottom, Stoppered (see Table 3)

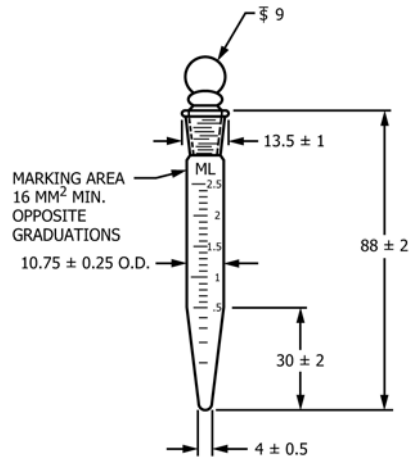

NOTE 1—All dimensions are in millimetres.
 NOTE 2—Wall thickness shall be approximately 1 mm.
 NOTE 3—Interior of bottom shall be rounded.

FIG. 4 Centrifuge Tube, Conical Bottom, Stoppered and Graduated

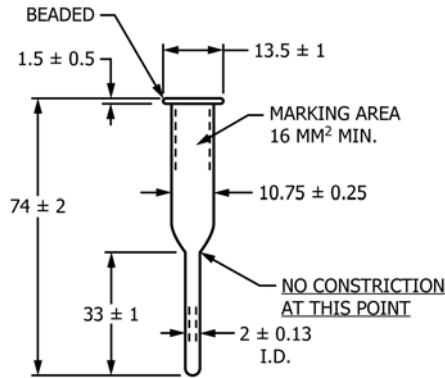

NOTE 1—Capacity approximately 2.6 mL.
 NOTE 2—All dimensions are in millimetres.
 NOTE 3—Wall thickness shall be approximately 1 mm.
 NOTE 4—Interior of bottom shall be rounded.

FIG. 5 Centrifuge Tube, Cylindrical Bottom, Plain

ASTM International takes no position respecting the validity of any patent rights asserted in connection with any item mentioned in this standard. Users of this standard are expressly advised that determination of the validity of any such patent rights, and the risk of infringement of such rights, are entirely their own responsibility.

This standard is subject to revision at any time by the responsible technical committee and must be reviewed every five years and if not revised, either reapproved or withdrawn. Your comments are invited either for revision of this standard or for additional standards and should be addressed to ASTM International Headquarters. Your comments will receive careful consideration at a meeting of the responsible technical committee, which you may attend. If you feel that your comments have not received a fair hearing you should make your views known to the ASTM Committee on Standards, at the address shown below.

This standard is copyrighted by ASTM International, 100 Barr Harbor Drive, PO Box C700, West Conshohocken, PA 19428-2959, United States. Individual reprints (single or multiple copies) of this standard may be obtained by contacting ASTM at the above address or at 610-832-9585 (phone), 610-832-9555 (fax), or service@astm.org (e-mail); or through the ASTM website (www.astm.org). Permission rights to photocopy the standard may also be secured from the Copyright Clearance Center, 222 Rosewood Drive, Danvers, MA 01923, Tel: (978) 646-2600; http://www.copyright.com/