



Standard Practice for Strain Controlled Thermomechanical Fatigue Testing¹

This standard is issued under the fixed designation E2368; the number immediately following the designation indicates the year of original adoption or, in the case of revision, the year of last revision. A number in parentheses indicates the year of last reapproval. A superscript epsilon (ϵ) indicates an editorial change since the last revision or reapproval.

1. Scope

1.1 This practice covers the determination of thermomechanical fatigue (TMF) properties of materials under uniaxially loaded strain-controlled conditions. A “thermomechanical” fatigue cycle is here defined as a condition where uniform temperature and strain fields over the specimen gage section are *simultaneously varied and independently controlled*. This practice is intended to address TMF testing performed in support of such activities as materials research and development, mechanical design, process and quality control, product performance, and failure analysis. While this practice is specific to strain-controlled testing, many sections will provide useful information for force-controlled or stress-controlled TMF testing.

1.2 This practice allows for any maximum and minimum values of temperature and mechanical strain, and temperature-mechanical strain phasing, with the restriction being that such parameters remain cyclically constant throughout the duration of the test. No restrictions are placed on environmental factors such as pressure, humidity, environmental medium, and others, provided that they are controlled throughout the test, do not cause loss of or change in specimen dimensions in time, and are detailed in the data report.

1.3 The use of this practice is limited to specimens and does not cover testing of full-scale components, structures, or consumer products.

1.4 The values stated in SI units are to be regarded as standard. No other units of measurement are included in this standard.

2. Referenced Documents

2.1 *ASTM Standards*:²

E3 Guide for Preparation of Metallographic Specimens

¹ This practice is under the jurisdiction of ASTM Committee E08 on Fatigue and Fracture and is the direct responsibility of Subcommittee E08.05 on Cyclic Deformation and Fatigue Crack Formation.

Current edition approved May 1, 2010. Published June 2010. Originally approved in 2004. Last previous edition approved in 2004 as E2368–04^{ε1}. DOI: 10.1520/E2368-10.

² For referenced ASTM standards, visit the ASTM website, www.astm.org, or contact ASTM Customer Service at service@astm.org. For *Annual Book of ASTM Standards* volume information, refer to the standard’s Document Summary page on the ASTM website.

- E4 Practices for Force Verification of Testing Machines
- E83 Practice for Verification and Classification of Extensometer Systems
- E111 Test Method for Young’s Modulus, Tangent Modulus, and Chord Modulus
- E112 Test Methods for Determining Average Grain Size
- E220 Test Method for Calibration of Thermocouples By Comparison Techniques
- E337 Test Method for Measuring Humidity with a Psychrometer (the Measurement of Wet- and Dry-Bulb Temperatures)
- E467 Practice for Verification of Constant Amplitude Dynamic Forces in an Axial Fatigue Testing System
- E606 Test Method for Strain-Controlled Fatigue Testing
- E1012 Practice for Verification of Testing Frame and Specimen Alignment Under Tensile and Compressive Axial Force Application
- E1823 Terminology Relating to Fatigue and Fracture Testing

3. Terminology

3.1 The definitions in this practice are in accordance with definitions given in Terminology E1823 unless otherwise stated.

3.2 *Definitions*:

3.2.1 Additional definitions are as follows:

3.2.2 *stress*, σ —stress is defined herein to be the engineering stress, which is the ratio of force, P , to specimen original cross sectional area, A :

$$\sigma = P/A \quad (1)$$

The area, A , is that measured in an unloaded condition at room temperature. See 7.2 for temperature state implications.

3.2.3 *coefficient of thermal expansion*, α —the fractional change in free expansion strain for a unit change in temperature, as measured on the test specimen.

3.2.4 *total strain*, ϵ_r —the strain component measured on the test specimen, and is the sum of the thermal strain and the mechanical strain.

3.2.5 *thermal strain*, ϵ_{th} —the strain component resulting from a change in temperature under free expansion conditions (as measured on the test specimen).

$$\epsilon_{th} = \alpha \cdot \Delta T \quad (2)$$

NOTE 1—For some materials, α may be nonlinear over the temperature range of interest.

3.2.6 *mechanical strain*, ϵ_m —the strain component resulting when the free expansion thermal strain (as measured on the test specimen) is subtracted from the total strain.

$$\epsilon_m = \epsilon_t - \epsilon_{th} \quad (3)$$

3.2.7 *elastic strain*, ϵ_{el} —the strain component resulting when the stress is divided by the temperature-dependent Young's Modulus (in accordance with Test Method E111).

$$\epsilon_{el} = \sigma/E(T) \quad (4)$$

3.2.8 *inelastic strain*, ϵ_{in} —the strain component resulting when the elastic strain is subtracted from the mechanical strain.

$$\epsilon_{in} = \epsilon_m - \epsilon_{el} \quad (5)$$

3.2.9 *strain ratio*, $R\epsilon$ —the ratio of minimum mechanical strain to the maximum mechanical strain in a strain cycle.

$$R\epsilon = \epsilon_{\min}/\epsilon_{\max} \quad (6)$$

3.2.10 *mechanical strain/temperature true phase angle*, ϕ —for the purpose of assessing phasing accuracy, this is defined as the waveform shift (expressed in degrees) between the maximum temperature response as measured on the specimen and the maximum mechanical strain response. For reference purpose, the angle ϕ is considered positive if the temperature response maximum leads the mechanical strain response maximum by 180° or less, otherwise the phase angle is considered to be negative.

3.2.11 *in-phase TMF*, ($\phi = 0^\circ$)—a cycle where the maximum value of temperature and the maximum value of mechanical strain occur at the same time (see Fig. 1a).

3.2.12 *out-of-phase (anti-phase) TMF*, ($\phi = 180^\circ$)—a cycle where the maximum value of temperature leads the maximum value of mechanical strain by a time value equal to $1/2$ the cycle period (see Fig. 1b).

4. Significance and Use

4.1 In the utilization of structural materials in elevated temperature environments, components that are susceptible to fatigue damage may experience some form of *simultaneously varying* thermal and mechanical forces throughout a given cycle. These conditions are often of critical concern because they combine temperature dependent and cycle dependent (fatigue) damage mechanisms with varying severity relating to the phase relationship between cyclic temperature and cyclic mechanical strain. Such effects can be found to influence the evolution of microstructure, micromechanisms of degradation, and a variety of other phenomenological processes that ultimately affect cyclic life. The strain-controlled thermomechanical fatigue test is often used to investigate the effects of simultaneously varying thermal and mechanical loadings under idealized conditions, where cyclic theoretically uniform temperature and strain fields are externally imposed and controlled throughout the gage section of the specimen.

5. Test Apparatus

5.1 *Testing Machine*—All tests shall be performed in a test system with tension-compression loading capability and verified in accordance with Practices E4 and E467. The test system

(test frame and associated fixtures) shall be in compliance with the bending strain criteria specified in Practices E606, E1012, and E467. The test system shall be able to independently control both temperature and total strain. In addition it shall be capable of adding the measured thermal strain to the desired mechanical strain to obtain the total strain needed for the independent control.

5.2 *Gripping Fixtures*—Any fixture, such as those specified in Practice E606, is acceptable provided it meets the alignment criteria specified in Practice E606, and the specimen fails within the uniform gage section. Specimens with threaded ends typically tend to require more effort than those with smooth shank ends to meet the alignment criteria; for this reason, smooth shank specimens are preferred over specimens with threaded ends. Fixtures used for gripping specimens shall be made from a material that can withstand prolonged usage, particularly at high temperatures. The design of the fixtures largely depends upon the design of the specimen. Typically, a combination of hydraulically-actuated collet grips and smooth shank specimens provide good alignment and high lateral stiffness.

5.3 *Force Transducer*—The force transducer shall be placed in series with the load train and shall comply with the specifications in Practices E4 and E467.

5.4 *Extensometers*—Axial deformation in the gage section of the specimen should be measured with an extensometer. The extensometers (including optical extensometers, using an appropriate calibration procedure) should qualify as Class B-2 or better in accordance with Practice E83.

5.5 *Transducer Calibration*—All transducers shall be calibrated in accordance with the recommendations of the respective manufacturers. Calibration of each transducer shall be traceable to the National Institute of Standards and Technology (NIST).

5.6 *Heating Device*—Specimen heating can be accomplished by various techniques including induction, direct resistance, radiant, or forced air heating. In all such cases, active specimen cooling (for example, forced air) can be used to achieve desired cooling rates provided that the temperature related specifications in 7.4 are satisfied.

NOTE 2—If induction is used, it is advisable to select a generator with a frequency sufficiently low to minimize “skin effects” (for example, preferential heating on the surface and near surface material with respect to the bulk, that is dependent on RF generator frequency) on the specimen during heating.

5.7 *Temperature Measurement System*—The specimen temperature shall be measured using thermocouples in contact with the specimen surface in conjunction with an appropriate temperature indicating device or non-contacting sensors that are adjusted for emissivity changes by comparison to a reference such as thermocouples.

NOTE 3—Direct contact between the thermocouple and the specimen is implied and shall be achieved without affecting the test results (for example, test data for a specimen when initiation occurred at the point of contact of the thermocouple shall be omitted from consideration). Commonly used methods of the thermocouple attachment are: resistance spot welding (outside the gage section), fixing by binding or pressure.

NOTE 4—Under inductive heating, thermocouple wires may act as heat

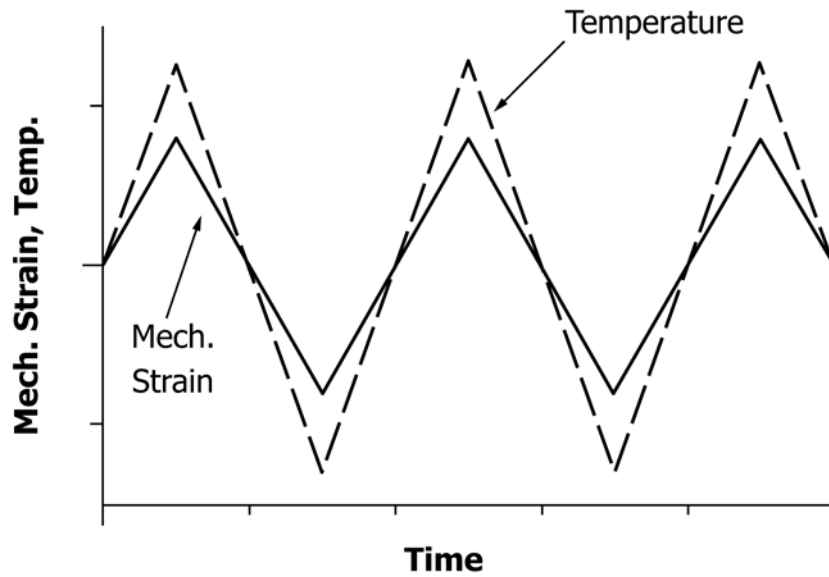

(a) In-phase TMF test ($\phi = 0$)

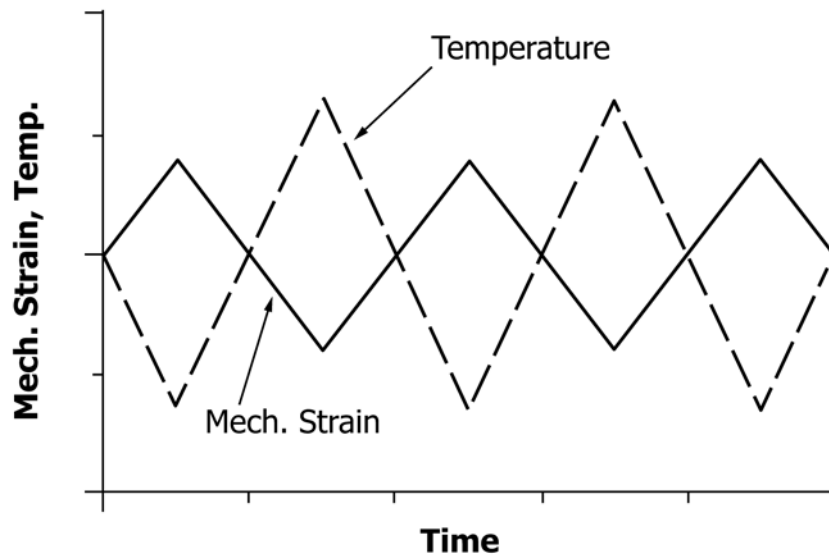

(b) Out-of-phase TMF test ($\phi = 180$)

FIG. 1 Schematics of Mechanical Strain and Temperature for In- and Out-of-Phase TMF Tests

sinks, and can thus lower the local specimen surface temperature. This effect may be substantial at high temperatures. (1)

5.7.1 Calibration of the temperature measurement system shall be in accordance with Method E220.

5.8 Data Acquisition System—A computerized system capable of carrying out the task of collecting and processing force, extension, temperature, and cycle count data digitally is recommended. Sampling frequency of data points shall be sufficient to ensure correct definition of the hysteresis loop

especially in the regions of reversals. Different data collection strategies will affect the number of data points per cycle needed, however, typically 200 points per cycle are required.

5.9 Alternatively, an analog system capable of measuring the same data may be used and would include:

5.9.1 An X-Y-Y recorder used to record force, extension, and temperature hysteresis loops,

5.9.2 A strip-chart recorder for several time-dependent parameters: force, extension and temperature,

5.9.3 A peak detector per signal, and

5.9.4 A cycle counter.

NOTE 5—The recorders may be replaced with storage devices capable of reproducing the recorded signals either in photographic or analog form. These devices are necessary when the rate of recorded signals is greater than the maximum slew-rate of the recorder. They allow permanent records to be reproduced subsequently at a lower rate.

6. Specimens

6.1 *Specimen Design Considerations*—All specimen designs shall be restricted to those featuring uniform axial gage sections, as these specimen designs offer a reasonable continuum volume for testing. Tubular specimens are preferred to solid specimen designs because they will tend to facilitate thermal cycling due to lower material mass and will reduce the potential for unwanted radial temperature gradients during thermal cycling (see 7.4.5).

6.2 *Specimen Geometry*—Specific geometries of tubular specimens will vary depending upon materials and testing needs. One of the more critical dimensions is wall thickness, which should be large enough to avoid instabilities during cyclic loading and thin enough to maintain a uniform temperature across the specimen wall. For polycrystalline materials, at least 10 to 20 grains should be present through the thickness of the wall to preserve isotropy. In order to determine the grain size of the material metallographic samples should be prepared in accordance with Methods E3 and the average grain size should be measured according to Test Method E112. Representative examples of tubular specimens, which have been successfully used in TMF testing, are included in Fig. 2. Further general guidance regarding specific geometric details can be gained from the uniform gage section specimen designs presented in E606. Solid specimen designs such as those presented in Practice E606 are also permitted. However, care shall be taken to ensure that radial temperature gradients during thermal cycling are not excessive; see 7.4.4 and associated note.

NOTE 6—For tubular specimens, wall thicknesses (WT) and outer diameters (OD) that fall in the following range are often found acceptable: $5 < OD/WT < 15$.

6.3 *Specimen Fabrication*—The procedure used for machining solid and tubular specimens shall meet all the specifications documented in Appendix X3 of Practice E606. In addition, the bore of the tubular specimen should be honed to inhibit fatigue crack nucleation from machining anomalies on the inner surface of the specimen.

7. Test Procedure

7.1 *Laboratory Environment*—All tests should be performed under a well-controlled laboratory environment. If testing is performed in air, uniform ambient temperature conditions should be maintained throughout the duration of the test. Relative humidity may be measured in accordance with E337 unless it has already been determined to have little or no effect on thermomechanical fatigue life. If an effect is present, relative humidity should be controlled. In either situation it should be carefully monitored and reported.

NOTE 7—It is strongly recommended that the relative humidity is

controlled within the laboratory environment because of its potential to affect strain gage based extensometry devices.

7.2 *Measurement of Test Specimen Dimensions*—The diameter(s) of the gage section (or width and thickness for the case of a rectangular cross section) should be measured in at least three different locations to an accuracy of 0.0125 mm (0.0005 in.) or better. Use the minimum of the values to compute the cross-sectional area.

NOTE 8—Because of the complexity of defining a gage length on the specimen due to the thermal expansion/contraction, it is recommended that the gauge length be fixed to the room temperature dimension. The error introduced by this definition is reasonably insignificant for engineering purposes.

7.3 *Specimen Loading*—The specimen should be loaded into the test machine without subjecting it to any damaging forces. (Forces shall not exceed the elastic limit during installation.) Care shall be taken not to damage the external (and internal in the case of a tube) gage section surface while mounting contact-type extensometers.

7.4 Temperature:

7.4.1 The temperature command cycle (maximums, minimums and rates) is to remain constant throughout the duration of the test, unless the aim of the program is to examine the effect of this parameter on the behavior of the material.

7.4.2 Through out the duration of the test, the temperature(s) indicated by the control sensor; for example, thermocouple(s) shall not vary by more than ± 2 K from the corresponding values of the initial temperature cycle.

NOTE 9—Currently, there is no standardized method for the dynamic calibration of temperature measurement devices. Therefore, for practical purposes, all temperature related requirements specified under non-static conditions assume that the temperature measuring system is calibrated under static conditions. Further, it is assumed that the temperature measurement system being used is sufficiently responsive so as to accurately indicate the specimen temperature under the dynamic conditions selected for the thermomechanical cycle.

7.4.3 The maximum allowable axial temperature gradient over the gage section at any given instant in time within the cycle shall be the greater of:

$$\pm 1\% \times T_{\max}, \text{ K} \quad (7)$$

or

$$\pm 3 \text{ K}$$

where T_{\max} is the maximum cyclic temperature given in K and measured under dynamic conditions. The maximum allowable transverse temperature gradient over the gage section at any given instant time within the cycle shall be the greater of:

$$\pm 1\% \times T_{\max}, \text{ K} \quad (8)$$

or

$$= 7 \cdot K$$

Where T_{\max} is the maximum cyclic temperature given in K and measured under dynamic conditions.

NOTE 10—It is advisable to also examine and restrict the dynamic temperature gradients existing through the thickness of the sample (that is, radial gradients) within the axial gage section. Such gradients are of particular concern when rapid temperature rates are used. This gradient should be measured by attaching thermocouples to inside and outside surfaces at the same axial location. When using solid specimens, a

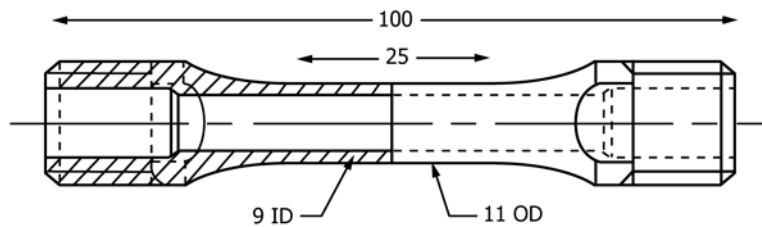
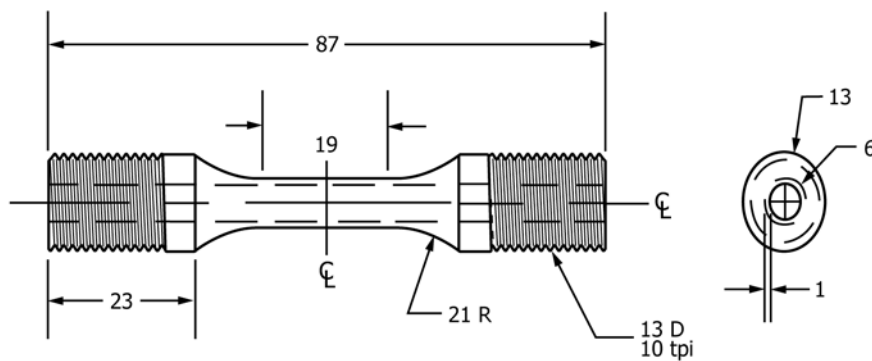
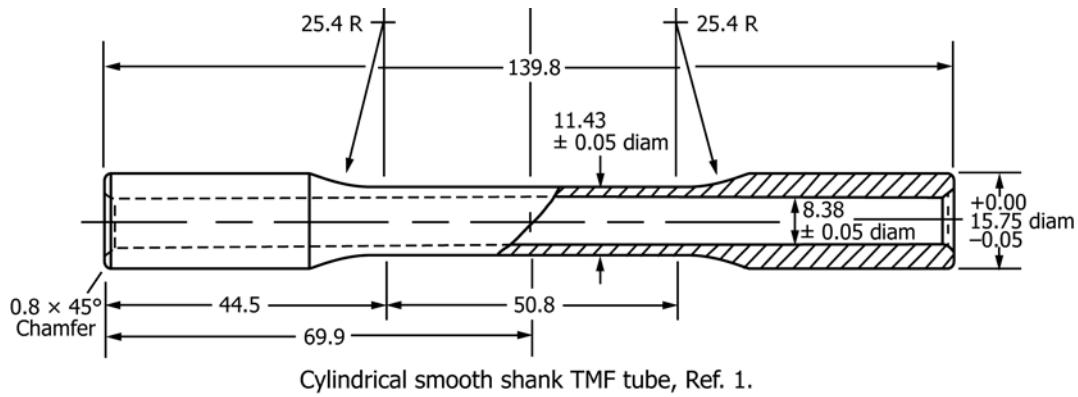

NOTE 1—All dimensions in mm.

NOTE 2—These are representative drawings of specimens that have been used in TMF studies, and NOT finished drawings for machines shop purposes.

FIG. 2 Samples of Thin-Walled Tubular Specimens for TMF Testing

verification sample should be drilled out, removing as little material as possible so as to enable a thermocouple to be mounted internally. The gradients should be restricted to those specified for the axial gage section. The interested reader is referred to (2) for additional background on the problems and practical bounds for axial and radial/transverse gradients.

7.4.4 The axial temperature gradient should be measured and adjusted under dynamic, thermal cycling conditions with the specimen at zero force prior to the commencement of thermomechanical loading. The thermal cycle to be used

during examination and refinement of the gage section gradient should be identical to that used for the thermomechanical cycle.

7.4.5 One measure of the accuracy and uniformity of the cyclic temperature control can be associated with the amount of hysteresis in the resulting ϵ_{th} response when the specimen is maintained at zero force. Ideally, no hysteresis should exist. The ϵ_{th} hysteresis existing at any given temperature point in the

cycle under zero force conditions shall be no greater than 5 % of the thermal ε_{range} induced.

7.5 Mechanical Strain:

7.5.1 The mechanical strain cycle shape shall remain constant throughout the duration of the test.

7.5.2 The mechanical strain (ε_m), as calculated by:

$$\varepsilon_m = \varepsilon_r - \varepsilon_m \quad (9)$$

shall not deviate from the desired value by more than 2 % of the mechanical strain range, at any given instant in time within the cycle. The desired value is established by the difference between the total strain and the compensating thermal strain. Both the mechanical strain and the temperature should remain cyclically constant and synchronized throughout the duration of the test. No cumulative error is permitted.

7.6 Thermal Strain Compensation:

7.6.1 To achieve a desired mechanical strain component, the temperature induced thermal expansion strain should be actively compensated during the test.

7.6.2 The temperature cycle used to establish the thermal strain compensation and assess the subsequent accuracy of the technique employed shall be that which exists once the specimen and immediate environment have achieved a state of dynamic temperature equilibrium during thermal cycling. This is generally achieved in 3 to 4 cycles.

7.6.3 Several methods can be employed to compensate for the induced thermal strains. These methods may vary depending upon specific testing equipment, control hardware and control software. These measured thermal strains can be fitted to a representative function or functions- it may be necessary to employ one for the heating phase and one for the cooling phase, dependent on the level of thermal hysteresis. Two commonly employed methods are presented in 7.6.3.1 and 7.6.3.2.

7.6.3.1 *Time-based Compensation*—The thermal strain component can be compensated by recording the free expansion thermal strains (specimen at zero force) as a function of cycle time prior to test initiation. The temperature cycle used shall be identical to that used for the subsequent thermomechanical fatigue test. These recorded values can be recalled at the appropriate corresponding times within the cycle to provide the strain compensation values.

7.6.3.2 *Temperature-based Compensation*—The thermal strain component can be compensated by recording the free expansion thermal strains (specimen at zero force) as a function of specimen temperature prior to test initiation. The temperature cycle used shall be identical to that used for the subsequent thermomechanical fatigue test. These values can be fit to an appropriately representative function or functions (typically, one for the heating portion of the cycle and one for the cooling) where temperature is the independent variable. The function(s) can then be used to calculate the compensation strain for any measured temperature during the thermomechanical fatigue test.

NOTE 11—It is generally not sufficiently accurate to take the free expansion thermal strain range, divide it into equal time- or temperature-based increments, and use this constant increment for subsequent compensation calculations. This approach does not sufficiently account for a

nonlinear thermal expansion (α) and further does not account for potential temperature lags experienced during reversals. The method described in 7.6.3.2 will minimize damage to the specimen, if a temperature problem develops during the test.

7.6.4 The accuracy of the thermal strain compensation routine should be checked prior to the initiation of the thermomechanical fatigue test by subjecting the specimen to thermal cycling in a strain controlled mode with zero mechanical strain. Here, the thermal strain compensation method will be used (exclusively) to actively compensate for the induced thermal expansion strain of the specimen. During this cycle, the maximum acceptable resulting stress shall be calculated from the peak mechanical strains from the specific test being considered, along with the corresponding moduli for the two temperatures at which the maximum, ε_{max}^m , and minimum, ε_{min}^m , mechanical strains occur:

$$\sigma_{max} = 2\% * \varepsilon_{max}^m * E(T \text{ at } \varepsilon_{max}^m) 2 \quad (10)$$

$$\sigma_{min} = 2\% * \varepsilon_{min}^m * E(T \text{ at } \varepsilon_{min}^m) 2 \quad (11)$$

$$\text{Allowable stress magnitude} \leq (\sigma_{max} - \sigma_{min}) / 2 \quad (12)$$

The absolute values of the measured stresses during the thermal cycling at zero mechanical strain shall not exceed the allowable stress range as computed above, ensuring that the mechanical strain range controlled during the actual test is within 2% of the desired mechanical strain range.

NOTE 12—Several thermal cycles are generally required to achieve dynamic temperature equilibrium, and the number of cycles required will be a function of several variables, including the specimen geometry and fixturing, and the test parameters. The user should be sensitive to the potential for adverse effects on the test results that may be introduced by these additional thermal cycles.

7.7 Temperature/Mechanical Strain Phasing:

7.7.1 The temperature value used in assessing the temperature/mechanical strain phasing shall be the feedback (actual) value measured in the gage section of the specimen during thermal cycling, and not the command value which is often controlled outside of the gage section, and may lead the response.

7.7.2 The mechanical strain response value used in assessing the temperature/mechanical strain phasing shall be as defined in 3.2.6, and used in 7.5.

7.7.3 Throughout the duration of the test, the error between the temperature/mechanical strain phasing shall not exceed the bounds established by:

$$\phi \pm 5^\circ \quad (13)$$

where ϕ is the desired phase shift for the test. No cumulative error is permitted.

7.7.4 The temperature/mechanical strain phase shift phasing shall be assessed prior to initiating the thermomechanical fatigue test. This assessment is evaluated under zero force and dynamic temperature equilibrium conditions.

7.8 *Command Waveforms*—The waveforms shall remain repeatable throughout the test program unless the test objective is to examine the effects of waveform type.

NOTE 13—It is often desired to maintain a constant cyclic period for the series of tests within a single test and test program. In so doing, changes in the imposed mechanical strain range will necessarily cause a change in mechanical strain rate. Discretion should be used when comparing TMF lives within a single test program where the test-to-test mechanical strain rates vary by more than a factor of 5.

7.9 *Start of Test*—All tests shall begin in the same direction of initial mechanical straining, tensile or compressive, unless the purpose of the study is to examine initial loading effects.

7.9.1 *Preliminary Measurements*—The tension and compression modulus values shall be checked at both room temperature as well as at the maximum temperature in the cycle to be run in order to verify (by comparison) that the extensometer is not slipping and is working properly. The modulus value so determined should not vary by more than 10% from the known value, for polycrystalline materials

7.9.2 *Commencement of TMF Loadings*—The specimen shall be thermally cycled until a state of dynamic temperature equilibrium is reached. Once this has occurred the thermal strain shall be recorded and used for compensation according to 7.6.3.1 or 7.6.3.2. The recorded temperature compensation should be checked by running the specimen in strain control at zero mechanical strain and monitoring force (see 7.6.4). The mechanical component of the TMF loading should then be started at the temperature/time point in the cycle when $\epsilon_m = 0$. In the case where the TMF cycle does not have a point of $\epsilon_m = 0$ (for example, cycles with $R > 0$), the mechanical component of loading should be gradually ramped to its minimum absolute value such that this value is reached at the appropriate temperature in the thermal cycle; at this point, the properly phased TMF cycle is immediately commenced. For large total strain amplitude tests, the mechanical component of strain may be increased to its final amplitude over multiple cycles to prevent overshoot. Such a gradual increase may also be required for materials that exhibit a serrated yielding phenomenon.

7.10 *Monitoring the Test*—The specimen temperature and total strain shall be monitored during the course of the test. The mechanical strain shall be maintained to the criteria set forth in 7.5, and the specimen temperature condition shall be maintained to the criteria set forth in 7.4.3.

7.11 *Failure Criteria*—The failure criterion used in the test series should be reported and may consist of one of the following:

7.11.1 *Specimen Separation*—Total separation or fracture of the specimen into two parts at some location within the uniform gage section. Total separation of the specimen outside the gage section shall be reported, but not as a specimen separation failure.

7.11.2 *Tensile Force Drop*—With this method, the specimen is considered to have failed when there is some specified amount (typically between 5 and 50 %) of force drop from the previously recorded peak force.

NOTE 14—An example of previously recorded cycle may be: the first cycle, or immediately prior cycle. Or, for strain softening materials, a continually decreasing force from the test outset to end is often observed. In this case, log versus log cycles may be plotted, which often provides a reasonably straight line. The failure cycle can then be defined to be any deviation of greater than, for example, 50% from this line.

7.11.3 *Microcracking*—A surface replication technique can be used for determining failure of the specimen. In this method, the fatigue test shall be interrupted at predetermined cyclic intervals to replicate the surface of the specimen with acetyl cellulose film. The film is subsequently examined for surface

connected cracks and failure is defined by the size of the largest crack observed (typically between 0.1 or 1.0 mm).

7.12 *End of Test*—The test is terminated when the conditions for the selected end of test criterion are fulfilled. The specimen-heating device shall be switched off as soon as the test terminates in order to limit the corrosion/oxidation of the specimen and cracked surfaces with a view to carrying out post mortem examinations. If the failure criterion is other than specimen separation, every effort shall be taken to ensure that the specimen will not be over-loaded during the test termination.

NOTE 15—It is recommended that post mortem examinations (metallographic and fractographic analysis) be conducted on the failed specimens. These will provide insight into various failure mechanics and also serve to make known any unusual phenomena that might stand to invalidate the test results.

7.13 *Test Interruption Sequence*—If a test is interrupted then care shall be taken to ensure that upon restart there is no significant overshoot in temperature or axial force or mechanical strain. (See 7.4 and 7.5).

NOTE 16—One approach is as follows: Prior to interrupting a strain controlled TMF test, record the maximum and minimum forces of the final 3 cycles. After the test has been discontinued record several free thermal cycles prior to cooling the specimen to room temperature and note the maximum and minimum strain values. The thermal strain range should not have changed but may have shifted due to gage section changes. Prior to removing the extensometer, a room temperature strain value is recorded at zero force and its position marked on the specimen. After specimen inspection the extensometer is placed at the markings and manually adjusted to the same strain value as when removed. Thermal cycling is initiated under zero force control and the thermal strains should match the post shutdown strains previously recorded. Adjust the extensometer until the thermal strains are matched. Upon restart under strain control, the forces recorded prior to shut down are matched. Some small amount of extensometer tare may be used to aid in matching the previous force level.

8. Report

8.1 The list of information that follows is suggested for inclusion in any report. When publishing in the open literature, include as much information as possible, independent of the author's purpose.

8.2 *Aim of the Study*—The test report should include full information on the aim of the study, indicating the specific objectives.

8.3 *Material*—All available material details should be reported. This should include the standardized product designation, the material composition in weight percent, material state at test initiation (annealing, heat-treatments, etc), microstructures/grain sizes and hardness.

8.4 *Specimen*—Provide a drawing of the specimen design along with details of the preparation procedures.

8.5 Description of Equipment:

8.5.1 Loading train details including force cell type and capacity, specimen fixtures and method of gripping.

8.5.2 Testing machine, including frame capacity, actuator type and capacity, and controller type.

8.5.3 Test control and data collection system including all digital and analog controllers, recorders and data recording equipment.

8.5.4 Heating and cooling systems details.

8.5.5 Thermocouple type and specific configuration.

8.5.6 Extensometer details including type, gage length, operating range and resolution.

8.6 *Description of Testing Environment—Test Methodology:*

8.6.1 Details describing the approach used for thermal strain compensation and verification of the accuracy of the approach, including the results (7.6.4).

8.6.2 Details describing the approach used for maintaining accurate temperature/mechanical strain phasing and verification of the accuracy of the approach.

8.6.3 Details describing the approach to temperature control and monitoring.

8.6.4 Details describing the approach to commencement of the TMF loadings.

8.6.5 Definition of failure.

8.6.6 Deviations from recommended test procedures.

8.7 *Test Conditions*—All of the test variables, including, mechanical strain limits, rates and waveform, temperature limits, rates and waveform, Re ratio, and temperature/mechanical strain phasing relationship.

8.8 *Specimen Alignment Results*

8.9 *Presentation of Results:*

8.9.1 *Presentation of Single Test Results*—Presentation of single test results shall include graphical plots (for an agreed upon cycle or cycles) of force as a function of time, total extensometer output as a function of time, temperature as a function of time, thermal strains as a function of time, mechanical strain as a function of time, and mechanical strain as a function of stress and temperature. A list of the following quantities shall also be included with the single test results:

maximum and minimum (for an agreed upon cycle or cycles) of: force, total extensometer output, and temperature. This tabulation shall also include the cycle time for the given cycle, the cycle number of the given cycle, and the cyclic life of the test. **Table 1** lists suggested, recommended representative data to be reported for a test series:

8.9.2 *Presentation of Results of Test Series*—Presentation of a test series shall include plots of maximum and minimum force as a function of either cycle number or, alternatively, cyclic life fraction, n/N_f .

9. Data Reduction and Analysis

9.1 *Preliminary Data*—The elastic modulus, as measured at room temperature, as well as measured at the maximum temperature for the cycle, shall be reported. The elastic modulus, as measured as a function of temperature within the cycle, $E(T)$ (see **Appendix X1**) may optionally be plotted and tabulated for the test series.

9.2 *Reduction of Recorded Data:*

9.2.1 *Determination of Stress-Mechanical Strain Data*—As a minimum, plots of the mechanical strain as a function of time (for a given cycle), and of stress as a function of mechanical strain, shall be made.

9.3 *Analysis of Results:*

9.3.1 *Determination of TMF Life*—The method used to determine the failure life of each test shall be reported, in addition to the failure life.

9.3.2 *Stress/Strain and Strain/Fatigue Life Relationships*—A plot of the cyclic life as a function of applied mechanical strain range shall be generated.

TABLE 1 Representative Data for Test Series (3)

Plots:	Representative cycles To be recorded:	Representative cycles To be reported:
Stress vs. time	logarithmic scheme: N = 1, 2, 3, 6, 10, 20, 30, 60, 100, ...	N = 1, mid life cycle
Mechanical strain vs. time	logarithmic scheme: N = 1, 2, 3, 6, 10, 20, 30, 60, 100, ...	N = 1, mid life cycle
Temperature vs. time	logarithmic scheme: N = 1, 2, 3, 6, 10, 20, 30, 60, 100, ...	N = 1, mid life cycle
Stress vs. mechanical strain (hysteresis loop)	logarithmic scheme: N = 1, 2, 3, 6, 10, 20, 30, 60, 100, ...	N = 1, mid life cycle
Mechanical strain vs. temperature	logarithmic scheme: N = 1, 2, 3, 6, 10, 20, 30, 60, 100, ...	N = 1, mid life cycle
Min and max of stress, stress range, and peak temperatures as a function of cycle number	All cycles	logarithmic scheme: N = 1, 2, 3, 6, 10, 20, 30, 60, 100, ...

APPENDIX

(Nonmandatory Information)

XI. MODULUS OF ELASTICITY DETERMINATION

X1.1 The temperature-dependent Young’s modulus as referenced in Test Method E111 should be measured and recorded at discrete temperatures over the full temperature range of the TMF cycle. If it is anticipated that the specimen is to be loaded in compression as well as tension, then the modulus should be determined by elastically exercising through tension and compression.

X1.2 The number of measurements needed is related to the magnitude of the temperature range and the strain or stress

magnitude at the temperatures of interest. As a guideline, modulus values should be measured at minimum, mean and maximum temperatures of the thermal cycle or at ΔT intervals where the modulus change over the ΔT is no more than 5 percent, whichever provides better resolution.

X1.3 In addition, it is recommended that the room temperature tension and compression modulus values be checked in order to verify (by comparison) that the extensometer is not slipping and is working properly.

REFERENCES

- (1) Meyer-Olbersleben, F., Engler-Pinto Jr., C.C., and Rezai-Aria, F., On Thermal Fatigue of Nickel Based Superalloys, Thermo-Mechanical Fatigue Behavior of Materials: 2nd Volume, ASTM STP 1263, M.J. Verrilli and M.G. Castelli, Eds. ASTM Philadelphia, 1995.
- (2) *High Temperature Thermo-Mechanical Fatigue: Testing Methodology, Interpretation of Data, and Applications.* Hahner, P., Klingelhoffner, H., Beck, T., Loveday, M., and Rinaldi, C., eds., *International Journal of Fatigue* 30 (2008) (special issue)
- (3) Affeldt E, Beck T, Klingelhoffner H, Loveday M, Rinaldi C. *Validated code of practice for strain controlled thermo-mechanical fatigue testing.* EUR 22281EN DG JRC–Institute for Energy. ISBN 92-79-02216-4, 2006.
- (4) Castelli, M. G., and Ellis, J. R., “Improved Techniques for Thermo-mechanical Testing in Support of Deformation Modeling,” *Thermo-Mechanical Fatigue Behavior of Material : First Volume, ASTM STP 1186*, H. Sehitoglu, Ed., American Society for Testing and Materials, Philadelphia, 1993, pp. 195-211.
- (5) Zamrik, S. A., Davis, D. C., and Firth, L. C., “Isothermal and Thermomechanical Fatigue of Type 316 Stainless Steels,” *Thermo-mechanical Fatigue Behavior of Materials: Second Volume, ASTM STP 1263*, M. J. Verrilli and M. G. Castelli, Eds., American Society for Testing and Materials, Philadelphia, 1996, pp. 96-116.
- (6) Chataigner, E., and Remy, L., “Thermomechanical Fatigue Behavior of Coated and Bare Nickel-Based Superalloy Single Crystals,” *Thermomechanical Fatigue Behavior of Materials: Second Volume, ASTM STP 1263*, M. J. Verrilli and M. G. Castelli, Eds., American Society for Testing and Materials, Philadelphia, 1996, pp. 3-26.
- (7) Hopkins, S. W., “Low-Cycle Thermal Mechanical Fatigue Testing,” *Thermal Fatigue of Materials and Components, ASTM STP 612*, D. A. Spera and D. F. Mowbray, Eds., American Society for Testing and Materials, 1976, pp. 157-169.
- (8) M. A. McGaw, S. R. Kalluri, S. D. Peteves, J. Bressers, Eds., “Fourth Symposium on Thermomechanical Fatigue,” *STP 1428*, American Society for Testing and Materials, 2003.

ASTM International takes no position respecting the validity of any patent rights asserted in connection with any item mentioned in this standard. Users of this standard are expressly advised that determination of the validity of any such patent rights, and the risk of infringement of such rights, are entirely their own responsibility.

This standard is subject to revision at any time by the responsible technical committee and must be reviewed every five years and if not revised, either reapproved or withdrawn. Your comments are invited either for revision of this standard or for additional standards and should be addressed to ASTM International Headquarters. Your comments will receive careful consideration at a meeting of the responsible technical committee, which you may attend. If you feel that your comments have not received a fair hearing you should make your views known to the ASTM Committee on Standards, at the address shown below.

This standard is copyrighted by ASTM International, 100 Barr Harbor Drive, PO Box C700, West Conshohocken, PA 19428-2959, United States. Individual reprints (single or multiple copies) of this standard may be obtained by contacting ASTM at the above address or at 610-832-9585 (phone), 610-832-9555 (fax), or service@astm.org (e-mail); or through the ASTM website (www.astm.org). Permission rights to photocopy the standard may also be secured from the Copyright Clearance Center, 222 Rosewood Drive, Danvers, MA 01923, Tel: (978) 646-2600; <http://www.copyright.com/>