



# Standard Test Methods for Fire Resistive Grease Duct Enclosure Systems<sup>1</sup>

This standard is issued under the fixed designation E2336; the number immediately following the designation indicates the year of original adoption or, in the case of revision, the year of last revision. A number in parentheses indicates the year of last reapproval. A superscript epsilon ( $\epsilon$ ) indicates an editorial change since the last revision or reapproval.

## INTRODUCTION

The protection of grease ducts under fire exposure conditions is an item of importance in securing constructions that are safe, and that are not a menace to neighboring construction nor to the public. Recognition of this is registered in the codes of many authorities, municipal and other agencies. Many types of enclosure materials are used to protect grease ducts. Normally, these enclosure materials are either applied to grease ducts in the field or are fabricated as part of the grease duct when shipped from the factory. Evaluating enclosure materials used to protect a grease duct from fire is an aid for predicting their fire performance and promotes uniformity in requirements of various authorities. To do this it is necessary that the fire-endurance properties of enclosure materials be measured and specified according to a common standard expressed in terms that are applicable alike to a wide variety of materials, situations, and conditions of exposure.

## 1. Scope

NOTE 1—The majority of this standard is based on the Model Building Code Evaluation Service<sup>2</sup> Acceptance Criteria titled *ACCEPTANCE CRITERIA FOR GREASE DUCT ENCLOSURE ASSEMBLIES, AC101*, which was created in 1994. Numerous design listings and labeled materials exist based on the provisions of this standard.

1.1 These test methods evaluate the enclosure materials and the grease duct enclosure systems using the following test methods: noncombustibility, fire resistance, durability, internal fire, and fire-engulfment with a through-penetration fire stop.

1.2 These test methods prescribe a standardized fire exposure for comparing the test results of the enclosure materials and grease duct enclosure systems. The results of these tests are one factor in assessing predicted fire performance of grease duct enclosure systems. Using these test results to predict the performance of actual grease duct enclosure systems requires the evaluation of test conditions.

1.3 The values stated in inch-pound units are to be regarded as standard. The values given in parentheses are mathematical conversions to SI units that are provided for information only and are not considered standard.

1.4 The text of these test methods references notes and footnotes which provide explanatory material. These notes and

footnotes (excluding those in tables and figures) shall not be considered as requirements of the fire test response standard.

*1.5 These test methods are used to measure and describe the response of materials, products, or assemblies to heat and flame under controlled conditions, but does not by itself incorporate all factors required for fire hazard or fire risk assessment of the materials, products, or assemblies under actual fire conditions.*

*1.6 These test methods do not purport to address all of the safety concerns, if any, associated with its use. It is the responsibility of the user of these test methods to establish appropriate safety and health practices and to determine the applicability of regulatory limitations prior to use.*

## 2. Referenced Documents

### 2.1 ASTM Standards:<sup>3</sup>

- [C518 Test Method for Steady-State Thermal Transmission Properties by Means of the Heat Flow Meter Apparatus](#)
- [C569 Test Method for Indentation Hardness of Preformed Thermal Insulations \(Withdrawn 1988\)<sup>4</sup>](#)
- [E84 Test Method for Surface Burning Characteristics of Building Materials](#)
- [E119 Test Methods for Fire Tests of Building Construction and Materials](#)

<sup>1</sup> This test method is under the jurisdiction of ASTM Committee E05 on Fire Standards and is the direct responsibility of Subcommittee E05.11 on Fire Resistance.

Current edition approved April 1, 2016. Published April 2016. Originally approved in 2004. Last previous edition approved in 2014 as E2336–14. DOI: 10.1520/E2336-16.

<sup>2</sup> ICC Evaluation Service, Inc. (ICBO Evaluation Service, Inc.) 5360 Workman Mill Road, Whittier, CA 90601-2298

<sup>3</sup> For referenced ASTM standards, visit the ASTM website, [www.astm.org](http://www.astm.org), or contact ASTM Customer Service at [service@astm.org](mailto:service@astm.org). For *Annual Book of ASTM Standards* volume information, refer to the standard's Document Summary page on the ASTM website.

<sup>4</sup> The last approved version of this historical standard is referenced on [www.astm.org](http://www.astm.org).

**E136** Test Method for Behavior of Materials in a Vertical Tube Furnace at 750°C

**E176** Terminology of Fire Standards

**E631** Terminology of Building Constructions

**E814** Test Method for Fire Tests of Penetration Firestop Systems

2.2 *Other Documents:*

**UL 385** Standard for Play Pipes for Water Supply Testing in Fire-Protection Service<sup>5</sup>

### 3. Terminology

3.1 *Definitions:* For definitions of terms used in this test method associated with fire issues refer to the definitions contained in Terminology **E176** and for building issues refer to the definitions contained in Terminology **E631**. When there is a conflict between Terminology **E176** and Terminology **E631** definitions, the definitions in Terminology **E176** shall apply.

3.2 *Definitions of Terms Specific to This Standard:*

3.2.1 *enclosure material, n*—the product applied to the grease duct to provide fire resistance.

3.2.2 *fire-separating element, n*—floors, walls, and partitions having a period of fire resistance determined in accordance with fire resistance test methods such as Test Methods **E119**.

3.2.3 *fire side, adj*—the face of the test assembly or test specimen exposed to the heat or flame or both of the test apparatus.

3.2.4 *grease duct (also known as kitchen exhaust grease duct), n*—a tube or conduit utilized for conveying air.

3.2.4.1 *Discussion*—It is usually equipped with an access opening for cleaning the orifice.

3.2.5 *grease duct enclosure system, n*—consists of the grease duct, an enclosure material(s), a support and fastening system, and an access opening for cleaning the grease duct.

3.2.6 *orifice, n*—the continuous hollow area or opening within the grease duct or combustion chamber.

3.2.7 *supporting construction, n*—the arrangement of building sections forming the fire-separating elements into which the grease duct enclosure system is installed.

3.2.8 *test assembly, n*—the complete assembly composed of a test specimen(s) together with its supporting construction.

3.2.9 *test specimen, n*—a material, product, or assemblage of a specific design, composition, density, and dimensions.

3.2.9.1 *Discussion*—the enclosure material or the grease duct enclosure system are examples of test specimens.

3.2.10 *unexposed side, n*—the face or part not directly exposed to the heat or flame or both of the test apparatus.

3.2.11 *unexposed surface thermocouple, n*—temperature-measuring device placed on the unexposed side.

### 4. Summary of Test Method

4.1 Representative test specimens of the enclosure material or the grease duct enclosure system are subjected to the

following tests. These test methods describe the following test sequence and procedures:

4.1.1 A noncombustibility test, Test Method **E136**, demonstrates the enclosure material's ability to resist combustion at a standardized temperature and duration.

4.1.2 A fire resistance test, Test Methods **E119**, illustrates the ability of the enclosure material to resist the effects of fire when applied in a vertical application.

4.1.3 A durability test intended to simulate the effects of long-term exposure of typical in-service conditions on the thermal transmission qualities of the enclosure materials when subjected to a modified version of Test Method **C518**.

4.1.4 An internal fire test uses two standardized fire exposures occurring inside the grease duct. Both tests illustrate the enclosure material's ability to resist thermal transmission of heat to the unexposed side in a horizontal application. The first standardized fire exposure is intended to simulate long term exposure of the enclosure material to a standardized service condition. The second standardized fire exposure is intended to simulate a standardized grease fire.

4.1.5 A fire-engulfment test uses a standardized fire exposure, the time temperature curve of Test Methods **E119**, to simulate a fire occurring on the outside of the grease duct, and demonstrates the ability of the grease duct enclosure system to remain intact without a through opening. The fire-engulfment test also tests the fastening methods used to secure the enclosure material to the grease duct and the supporting system. The fire-engulfment test also provides a means to test a through-penetration fire stop to determine its compatibility with the grease duct enclosure system.

### 5. Significance and Use

5.1 These test methods are intended to evaluate the ability of the grease duct enclosure system to do the following:

5.1.1 Resist the effects of a standardized fire exposure,

5.1.2 Retain its integrity, or

5.1.3 Exhibit both properties dependent upon the type of test assembly involved during a predetermined test exposure.

5.2 These test methods provide for the following measurements and evaluations where applicable:

5.2.1 Capability of the enclosure material to resist flaming (combustion) when exposed to 1382°F (750°C).

5.2.2 Loadbearing ability of the tested support system and fastening system to carry the load of the grease duct enclosure system during a standardized fire-engulfment test.

5.2.3 Ability of a fire stop to meet the requirements of Test Method **E814** when used with a grease duct enclosure system.

5.2.4 Ability of the enclosure material to resist the passage of flames and hot gases during a standardized fire resistance test and a standardized internal fire test.

5.2.5 Transmission of heat through the grease duct and the enclosure material(s) during a standardized fire resistance test and a standardized internal fire test.

5.2.6 Ability of the grease duct enclosure system to resist the passage of water during a standardized hose stream test.

5.2.7 Comparative measurement of temperature aging of the enclosure material(s) when subjected to standardized cyclic thermal transmissions.

<sup>5</sup> Available from Underwriters Laboratories (UL), Corporate Progress, 333 Pfingsten Rd., Northbrook, IL 60062.

5.3 These test methods do not provide the following:

5.3.1 Full information as to performance of the enclosure material or the grease duct enclosure system constructed with components, densities, or dimensions other than those tested.

5.3.2 Evaluation of the degree by which the enclosure material or grease duct enclosure system contributes to the fire hazard by generation of smoke, toxic gases, or other products of combustion.

5.3.3 Measurement of the degree of control or limitation of the passage of smoke or products of combustion through the grease duct enclosure system.

5.3.4 Measurement of flame spread over the surface of the grease duct enclosure system.

NOTE 2—The information in 5.3.2 – 5.3.4 is usually determined by other suitable test methods. For example, 5.3.4 is typically determined using Test Method E84.

5.4 In these test methods, the test specimens are subjected to one or more specific tests under laboratory conditions. When different test conditions are substituted or the end-use conditions are changed, it is not always possible by, or from, these test methods to predict changes to the characteristics measured. Therefore, the results of these laboratory tests are valid only for the exposure conditions described in these test methods.

5.5 Various test methods in these test methods require a test specimen to be exposed to a standard fire that is controlled to achieve specified temperatures throughout a specified time period. The fire-engulfment and vertical fire resistance tests are followed by the application of a standardized hose stream test. These test methods provide a relative measure of the fire-test-response of comparable enclosure materials and grease duct enclosure systems under these exposure conditions. The fire exposure is not representative of all fire conditions because conditions vary with changes in the amount, nature and distribution of fire loading, ventilation, compartment size and configuration, and heat sink characteristics of the compartment. Variation from the test conditions or test specimen construction, such as size, materials, method of assembly, also affects the fire-test-response. For these reasons, evaluation of the variation is required for application to construction in the field.

## 6. Apparatus

6.1 *Combustion Chamber*—A tubular L-shaped assembly used with a gas-fired burner(s) capable of delivering the minimum interior temperatures for the internal fire test as specified in Section 14.

NOTE 3—An example of such a device is an L-shaped square steel tube measuring  $84 \pm 1$  in. by  $96 \pm 1$  in. on the exterior legs with an orifice measuring a minimum 24 by 24 in. and insulated on the interior with a minimum 2 in. thick 8 lb/ft<sup>3</sup> density ceramic fiber blanket as shown in Fig. 1.

6.2 *Gas-fired Burner*—A device that produces heat and flame from a gas undergoing combustion that is capable of providing the minimum temperatures to perform the internal fire test as specified in Section 14.

NOTE 4—A burner with a minimum heat input (Btu/h) of at least 925 times the cross-sectional area of the test assembly orifice, in.<sup>2</sup> (mm<sup>2</sup>), has been proven adequate to produce the 500°F (260°C) internal temperature

during that exposure period and a burner with a minimum heat input (Btu/h) of at least 4025 times the cross-sectional area of the test assembly orifice, in.<sup>2</sup> (mm<sup>2</sup>), has been proven adequate to produce the 2000°F (1093°C) internal temperature during that exposure period. For rectangular ducts, the cross-sectional area shall be modified when determining the minimum heat input. For rectangular ducts, an equivalent diameter (DE) and the equivalent cross-sectional area shall be determined as follows:

$$D_E = 1.30(ab)^{0.625}/(a + b)^{0.25} \quad (1)$$

where:

$a$  = length of one side of duct,  
 $b$  = length of adjacent side of duct, and  
*Equivalent Area*<sup>6</sup> =  $(D_E/2)^2$

6.3 *Furnace*—An enclosed furnace facility capable of controlling a fire to the time-temperature curve in Test Methods E119. A vertical furnace with a test frame is shown in Fig. 2 and a horizontal furnace is shown in Fig. 3.

6.4 *Furnace Thermocouples:*

6.4.1 The E119 furnace thermocouples shall:

6.4.1.1 Be protected by sealed porcelain tubes having a nominal 3/4-in. (19-mm) outside diameter and 1/8-in. (3-mm) wall thickness, or, as an alternative, in the case of base metal thermocouples, protected by a standard 1/2-in. (13-mm) diameter wrought steel or wrought iron pipe of standard weight, and

6.4.1.2 Have a time constant between the range of 5.0 to 7.2 min while encased in the tubes described in 6.4.1.1.

6.4.2 Other types of E119 protection tubes or pyrometers shall be used only when they give the same indications under test conditions as those of 6.4.1.2 within the limit of accuracy that applies for furnace-temperature measurements.

NOTE 5—A typical thermocouple assembly meeting these time constant requirements is fabricated by fusion-welding the twisted ends of No. 18 gage Chromel-Alumel wires, mounting the leads in porcelain insulators and inserting the assembly so the thermocouple bead is approximately 0.5 in. (25 mm) from the sealed end of the standard weight nominal 1/2-in. (25-mm) iron, steel, or Inconel<sup>7</sup> pipe. The time constant for this and for several other thermocouple assemblies was measured in 1976. Another option is to calculate the time constant from knowledge of its physical and thermal properties.<sup>8</sup>

6.5 *Pressure-sensing Probes*—Where applicable, tolerances are  $\pm 5\%$  of dimensions shown in Fig. 4 or Fig. 5.

6.5.1 The pressure-sensing probes shall be either a T-shaped sensor as shown in Fig. 4, or a tube sensor as shown in Fig. 5

6.6 *Unexposed Surface Thermocouples:*

6.6.1 The unexposed surface thermocouple wires, which shall be covered by the thermocouple pads described in 6.7 during testing, shall not be heavier than No. 18 B and S gage (0.040 in.) (1.02 mm), and shall be electrically insulated with heat-resistant and moisture-resistant coatings.

6.7 *Thermocouple Pads:*

6.7.1 The thermocouple pads used to cover each thermocouple on the unexposed side of the test specimen or test assembly shall be made of either asbestos or refractory fiber materials. All thermocouple pads shall be square and measure

<sup>6</sup> ASHRAE Fundamentals Handbook, Chapter 32: Duct Design.

<sup>7</sup> Inconel is a registered trade name of INCO Alloys, Inc., 3800 Riverside Dr., Huntington, WV 25720.

<sup>8</sup> Supporting data is available from ASTM International Headquarters. Request RR:E05-1001.

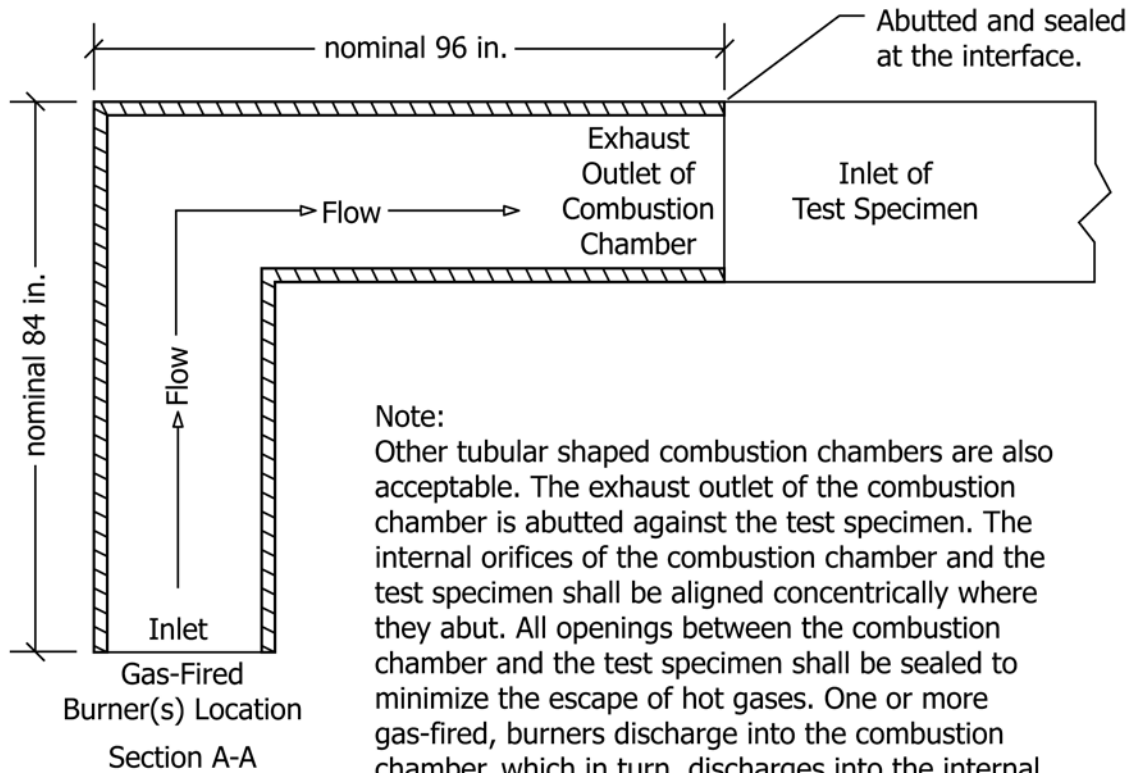

**Note:**  
 Other tubular shaped combustion chambers are also acceptable. The exhaust outlet of the combustion chamber is abutted against the test specimen. The internal orifices of the combustion chamber and the test specimen shall be aligned concentrically where they abut. All openings between the combustion chamber and the test specimen shall be sealed to minimize the escape of hot gases. One or more gas-fired, burners discharge into the combustion chamber, which in turn, discharges into the internal cavity of the test specimen.

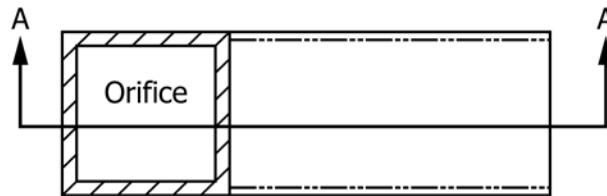

**FIG. 1 A Rectangular Combustible Chamber**

6 ± 1/8 in. (152 ± 3 mm) on each side. The properties of the thermocouple pads shall have the following characteristics in 6.7.1.1 or 6.7.1.2.

**NOTE 6**—There are potential health concerns associated with the use of asbestos pads. Most, if not all United States' laboratories do not use asbestos pads. Further, in the United States these pads are very difficult to acquire. However, ASTM International standards are used internationally and some countries still use the asbestos pads.

**6.7.1.1 Asbestos Pads**

(a) Thermocouple pads shall be dry, felted amosite asbestos, and free of organic additives.

(b) The thermocouple pads shall be 0.40 ± 0.05 in. (10.2 ± 1.3 mm) thick. The thickness measurement shall be made under the light load of a standard 1/2-in. (12.7-mm) diameter pad of a dial micrometer gage.

(c) The thermocouple pads shall have a dry weight of 0.260 ± 0.026 lb (0.12 ± 0.01 kg).

(d) The thermal conductivity of the thermocouple pads at 150°F (66°C) shall be 0.38 ± 0.027 Btu-in./h-ft<sup>2</sup>-°F [0.055 ± 0.003 W/(m-°K)].

(e) The thermocouple pads shall have a hardness (on soft face) of 1.57 ± 0.07 in. (4.0 ± 1.8 mm) or 10-25 (modified Brinell). Indentation shall be determined in accordance with Test Method C569. Modified Brinell values of hardness shall be obtained by the relationship:

$$\text{Hardness} = 2.24/y \tag{2}$$

where:

y = the measured indentation, in. (mm).

**6.7.1.2 Refractory Fiber Pads**

(a) Thermocouple pads shall be dry, felted refractory fiber pads.



1. Furnace
2. Exhaust Flue
3. View Ports
4. Gas Burners
5. Thermocouple Tubes
6. Test Frame
7. Test Specimen Location
8. Loading Jacks (when required)

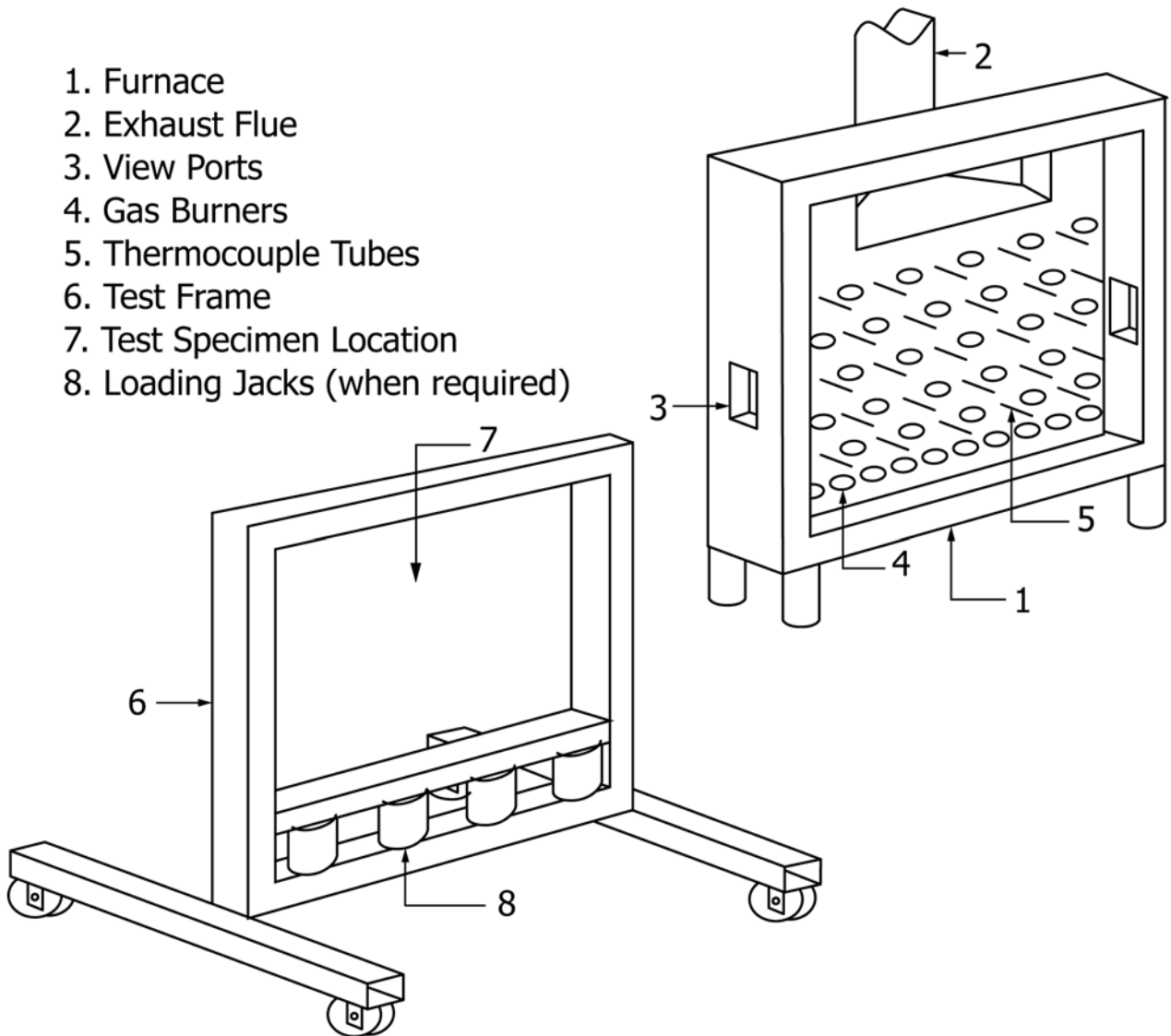

NOTE 1—The test specimen can be tested in a test frame equipped with loading jacks provided that no load is applied to the test specimen.

FIG. 2 A Vertical Furnace and Test Frame

(b) The thermocouple pads shall be  $0.375 \pm 0.063$  in. ( $9.5 \pm 1.6$  mm) thick. The thickness measurement shall be made under the light load of a standard  $\frac{1}{2}$ -in. (12.7-mm) diameter pad of a dial micrometer gage.

(c) The thermocouple pads shall have a dry weight of  $0.147 \pm 0.053$  lb ( $67 \pm 24$  g).

(d) The thermal conductivity of the thermocouple pads at  $150^\circ\text{F}$  ( $66^\circ\text{C}$ ) shall be  $0.37 \pm 0.03$  Btu-in./h-ft<sup>2</sup>-°F [ $0.053 \pm 0.004$  W/(m·°K)].

(e) The thermocouple pads shall have a hardness (on soft face) of  $0.75 \pm 0.025$  in. ( $1.9 \pm 0.6$  mm). Indentation shall be determined in accordance with Test Method C569. Modified Brinell values of hardness shall be obtained by the relationship:

$$\text{Hardness} = 2.24/y \quad (3)$$

where:

y = the measured indentation, in. (mm).

#### 6.8 Differential Pressure Measurement Instruments:

6.8.1 The differential pressure measurement instrument shall be:

6.8.2 A manometer or equivalent transducer

6.8.3 Capable of reading in graduated increments of no greater than 0.01 in. H<sub>2</sub>O (2.5 Pa) with a precision of not less than  $\pm 0.005$  in. H<sub>2</sub>O ( $\pm 1.25$  Pa).

#### 6.9 Hose Stream Delivery System:

6.9.1 The hose stream delivery system shall consist of:

6.9.1.1 A standard  $2\frac{1}{2}$ -in. (64-mm) diameter hose attached to a national standard play pipe as described in UL 385.

6.9.1.2 The play pipe shall have a length of  $30 \pm \frac{1}{4}$  in. ( $762 \pm 6$  mm) and shall be equipped with a standard  $1\frac{1}{8}$ -in. (29-mm) discharge tip of the standard-taper-smooth-bore pattern without shoulder at the orifice.

6.9.1.3 The play pipe shall be fitted with a standard  $2\frac{1}{2}$ -in. (64-mm) inside dimension by 6-in. (153-mm) long nipple mounted between the hose and the base of the play pipe.

- 1. Furnace
- 2. Exhaust Flue
- 3. View Ports
- 4. Access Door
- 5. Gas Burners
- 6. Thermocouple Tube Locations
- 7. Test Specimen Location

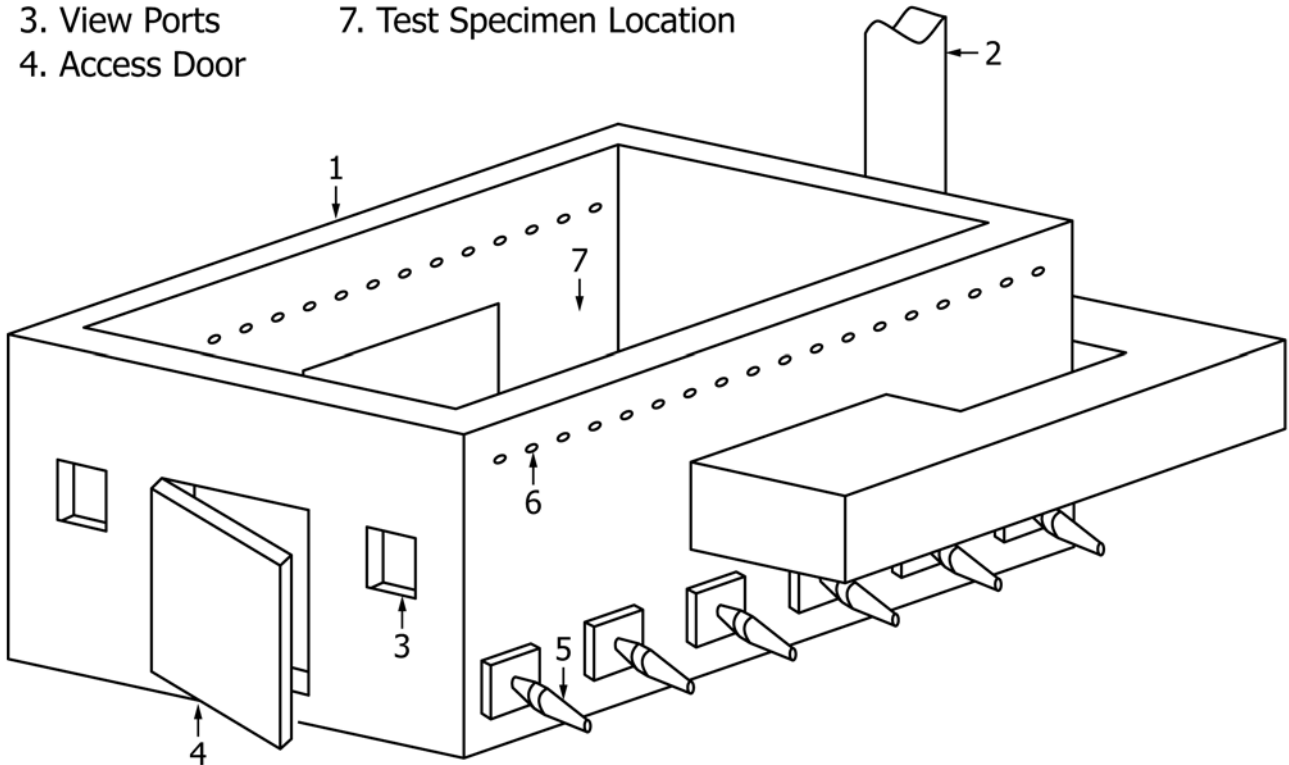

NOTE 1—The test specimen is lowered into the furnace and held up by the supporting construction.

FIG. 3 A Horizontal Furnace

6.9.1.4 A pressure tap for measuring the water pressure at the base of the nozzle shall be normal to the surface of the nipple, shall be centered in its length, and shall not protrude into the water stream.

6.9.1.5 A suitable pressure gage capable of reading a minimum of 0-50 psi (0-344.8 kPa) and graduated into no greater than 2-psi (13.8-kPa) increments shall be used to measure the water pressure.

## 7. Sampling, Units, Test Specimens, and Test Assemblies

NOTE 7—Some evaluation services require an approved inspection agency or certification body to witness the enclosure material production to establish traceability to the test specimens and that the enclosure material be representative of the product as applied in the field. Enclosure materials are normally required to be classified as noncombustible, as defined by the International Building Code (2000).

### 7.1 Noncombustibility Test Specimens:

7.1.1 Each test specimen shall be prepared in accordance with Test Method E136.

7.1.2 Properties of the materials, such as density and dimensions, used in the test specimen shall be determined and recorded. Document the description of the enclosure material test specimens. Include such information as the lot number, trade name, and all recorded information.

### 7.2 Fire Resistance Test Specimens:

7.2.1 Each test specimen shall be prepared in accordance with Test Methods E119.

NOTE 8—When applying for evaluation reports, it is important that the same type, density, and dimensions of enclosure material be used in all the fire resistance tests referenced in this standard because sometimes this standard is used to approve enclosure materials and their application. Some certification services use this standard to publish design listings and certify enclosure materials bearing their label.

7.2.2 Properties of the materials, such as density and dimensions, used in the test specimen shall be determined and recorded. Document the description of the enclosure material test specimens. Include such information as the lot number, trade name, and all recorded information.

NOTE 9—Some certification and evaluation services require that the same type, density, and dimensions of enclosure material be used in all the fire resistance tests referenced in this standard because this standard can be used to approve enclosure materials and their application. Some certification or evaluation services use this standard to publish design listings, approve or certify enclosure materials bearing their label or designation.

7.2.3 Test Assembly—The test assembly shall be a vertical wall consisting of the following:

NOTE 10—Some certification and evaluation services require use of the same materials and construction (that is, same type and thickness of steel) in all the fire resistance tests referenced in this standard. Some certification

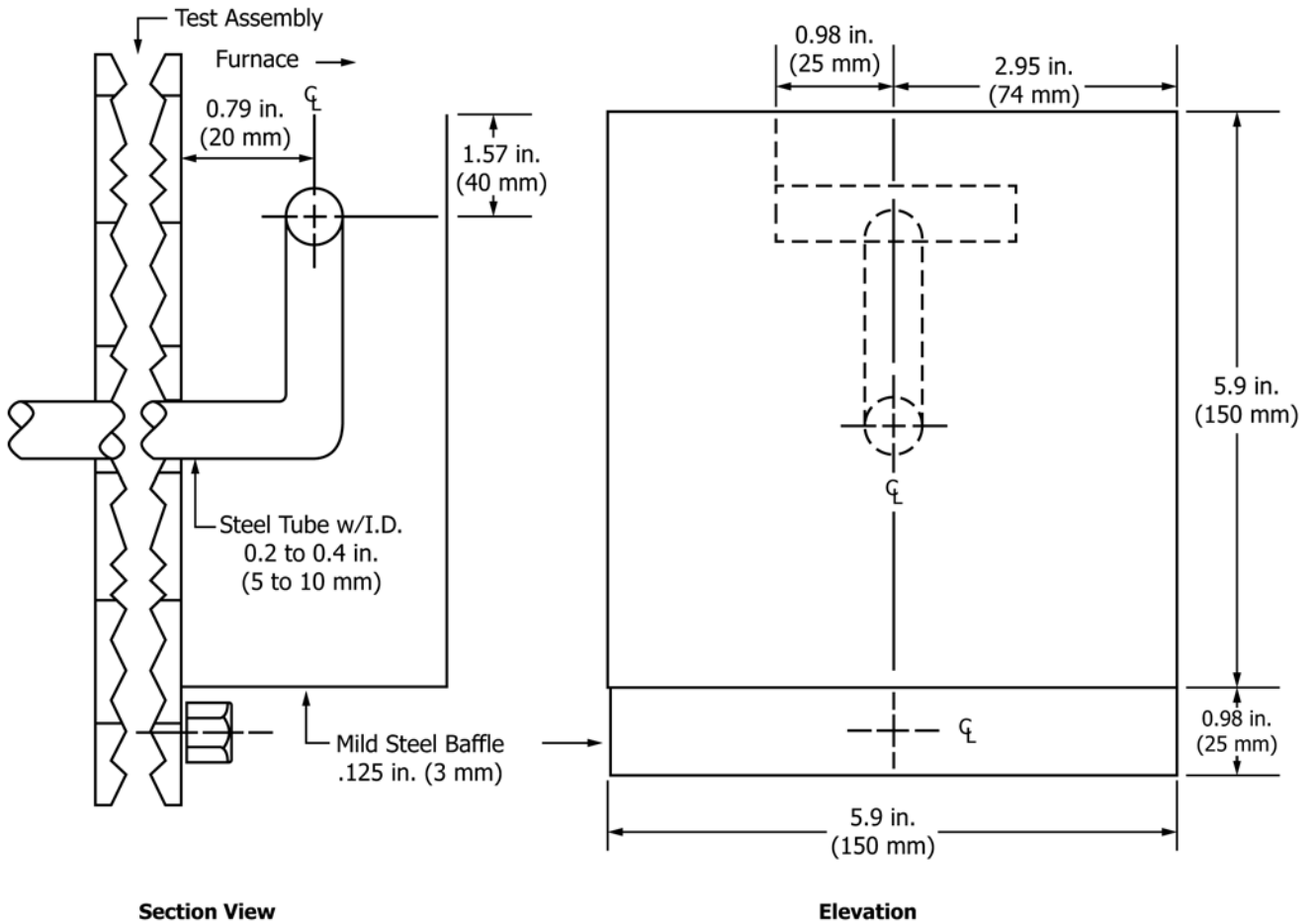
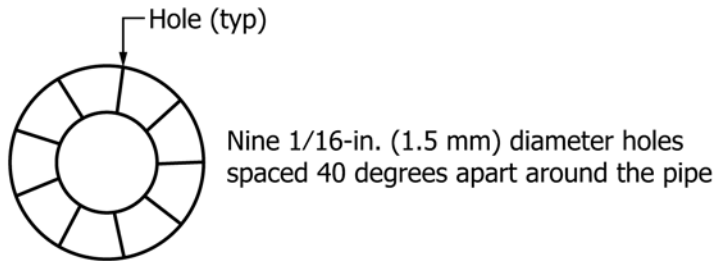
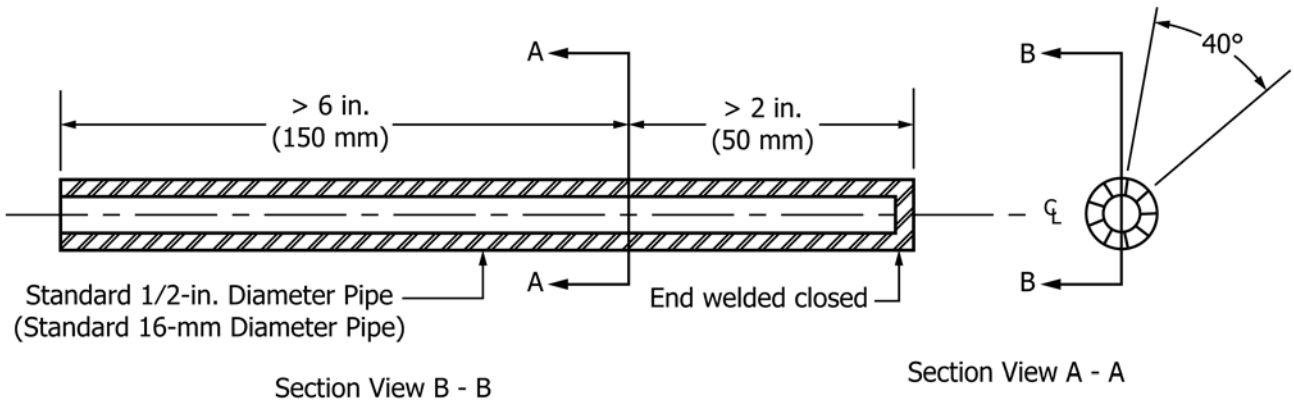

FIG. 4 T-Shaped Pressure Sensor



Enlarged Section View A - A

FIG. 5 Tube Sensor

or evaluation services use this standard to publish evaluation reports, design listings, approve or certify enclosure materials bearing their label or designation.

7.2.3.1 The area exposed to fire shall be not less than 100 ft<sup>2</sup> (9.29 m<sup>2</sup>), with neither dimension less than 9 ft (2.7 m). The test specimen shall not be restrained on its vertical edges. Reference Fig. 6.

7.2.3.2 Use 20 GA 3-5/8 by 1-1/4 in. (92 by 32 mm) steel studs, spaced 30 ± 1 in. (762 ± 25 mm) on center,

7.2.3.3 Stitch weld a single layer of sheet steel to the steel studs. Vertical joints in the sheet steel shall be centered on the steel studs. The flat side of the sheet steel shall be the fire side of the test assembly. Document the type of sheet steel and its thickness.

7.2.3.4 The fire side of the test assembly shall be covered with the enclosure material, installed in accordance with the test sponsor's installation instructions. Document the installation method in detail.

7.2.3.5 Equip the test assembly with at least one access opening. Document the access opening construction, location, and size. The test assembly shall include at least one transverse and longitudinal joint of the enclosure material installed in accordance with the test sponsor's instructions. Document the type of joints used and the test sponsor's installation method.

7.2.3.6 Seal the test assembly against the furnace with an insulating gasket located between the test assembly and the vertical furnace referenced in 6.3.

7.3 Durability Test Specimens:

7.3.1 Eight test specimens of the enclosure material shall be required.

7.3.2 The test specimens shall be prepared in accordance with Test Method C518.

7.3.3 Properties of the materials, such as density and dimensions, used in the test specimen shall be determined and recorded. Document the description of the enclosure material

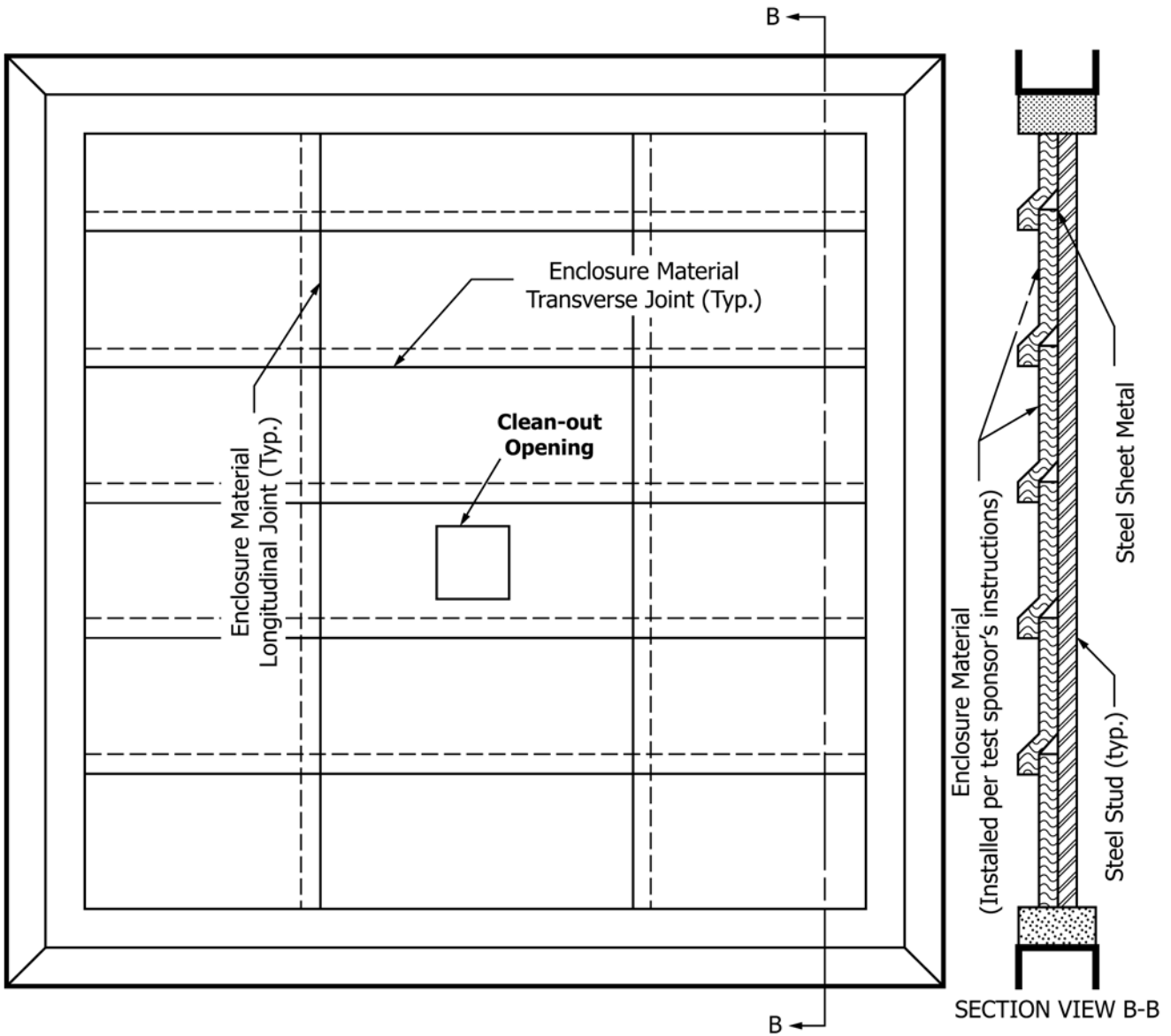

FIG. 6 A Vertical ASTM E119 Test Assembly with Enclosure Material Side Shown



test specimens. Include such information as the lot number, trade name, and all recorded information.

7.4 Internal Fire Test Specimens:

7.4.1 The test specimen shall be representative of the construction for which Conditions of Compliance is desired, as to materials, workmanship, and details such as dimensions of parts, and shall be built under conditions representative of those in building construction and operation. The physical properties of the materials and ingredients used in the test specimen shall be determined and documented.

7.4.2 Each test specimen shall be prepared in accordance with Test Methods E119.

7.4.3 Properties of the materials, such as density and dimensions, used in the test specimen shall be determined and recorded. Document the description of the enclosure material test specimens. Include such information as the lot number, trade name, and all recorded information.

7.4.4 Construct an L-shaped grease duct with its orifice having the largest width or cross-sectional area or both for which the Conditions of Compliance are desired and having a length and a height as shown in Fig. 7. Construct the grease duct using the same type of steel and thickness documented in 7.2. Document all physical characteristics of the grease duct, including the shape, dimensions, material, and construction techniques.

7.4.5 Create an access opening, using the construction and size documented in 7.2, on the side of the grease duct between the internal thermocouples and the vertical leg of the grease duct. Document the access opening construction, location, and size.

NOTE 11—A successful test on the grease duct in 7.4 normally qualifies the enclosure material for use on rectangular ducts with equal or less widths and equal or less cross-sectional areas, and round ducts with equal or less cross-sectional areas.

7.4.6 Construct the grease duct with at least two joints. Document the types of joints being tested.

NOTE 12—When seeking approval from some evaluation services, it is important that the joints comply with the minimum requirements of NFPA 96<sup>9</sup> Standard for Ventilation Control and Fire Protection of Commercial Cooking Operations for the grease duct size and gage of steel being tested. The International Mechanical Code (IMC)<sup>10</sup> also provides minimum requirements for the construction of grease ducts.

7.4.7 Support the grease duct in accordance with the test sponsor’s recommendations for type and dimensions of support system. Document the type and dimensions of the support system.

7.4.8 Install the enclosure material in accordance with the test sponsor’s instructions. Document the application of the enclosure material.

7.4.9 Align an access opening in the enclosure system with the grease duct access opening in accordance with the test sponsor’s instructions. Document the method of installation.

7.5 Fire-Engulfment Test Specimens:

7.5.1 The test specimen shall be representative of the construction for which Conditions of Compliance is desired, as to materials, workmanship, and details, such as dimensions of parts, and shall be built under conditions representative of those in building construction and operation. The physical properties of the materials and ingredients used in the test specimen shall be determined and documented.

7.5.2 The test specimen shall be prepared in accordance with Test Methods E119.

7.5.3 Properties of the materials, such as density and dimensions, used in the test specimen shall be determined and recorded. Document the description of the test specimens. Include such information as the lot number, trade name, and all recorded information.

7.5.4 Construct the test assembly using the following:

<sup>9</sup> Available from National Fire Protection Association (NFPA), 1 Batterymarch Park, Quincy, MA 02269-9101.

<sup>10</sup> Available from International Code Council (ICC), 5203 Leesburg Pike, Suite 600, Falls Church, VA 22041.

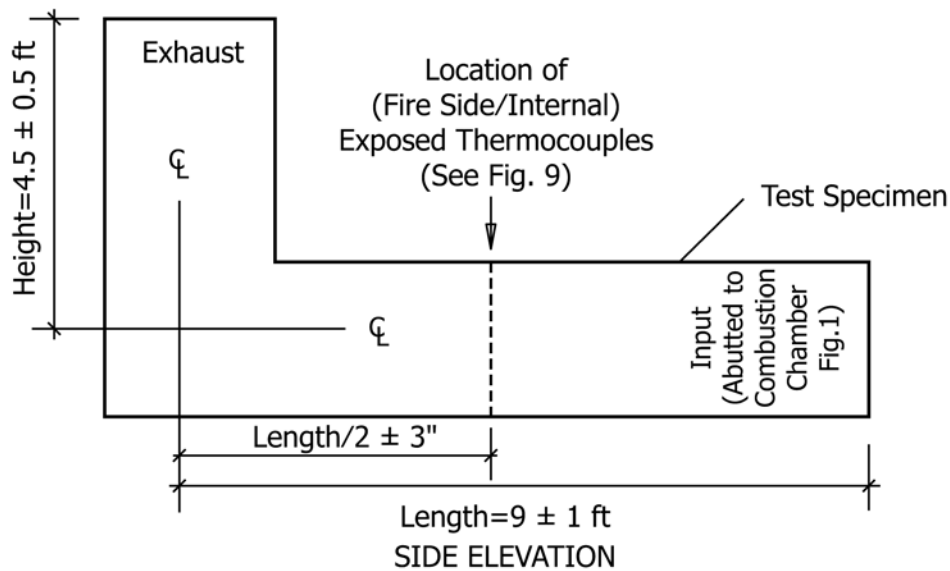

FIG. 7 L-Shaped Test Specimen

7.5.5 Use the type of steel and thickness documented in 7.2 to construct an L-shaped grease duct 10 ft ± 1 in. (3.05 m ± 2.54 cm) long and 4 ft ± 1 in. (1.22 m ± 2.54 cm) high. Use the orifice's dimensions, shape, joints, and access opening that are documented in 7.4 to construct the grease duct. The orifice at the horizontal end of the grease duct exposed to fire shall be capped with sheet steel of the same gage and thickness as the grease duct. Weld the cap in place with a continuous liquid tight weld. Reference Fig. 8.

7.5.6 Extend the vertical end of the grease duct a minimum of 24 in. (610 mm) above the unexposed side of the horizontal fire-separating element that is serving as one surface of the furnace enclosure.

7.5.7 Leave the vertical end of the grease duct open to the atmosphere.

7.5.8 Suspend the grease duct from a horizontal fire-separating element using a support system. Use a support system specified by the test sponsor and install the support system in accordance with the test sponsor's installation instructions. Document the support system and installation method.

NOTE 13—A successful test on the grease duct in 7.5 normally qualifies the enclosure material for use on rectangular ducts with equal or less

widths and equal or less cross-sectional areas, and round ducts with equal or less cross-sectional areas.

7.5.9 The horizontal fire-separating element shall have a hole through it, which is sized in accordance with the test sponsor's specification, for application of a through-penetration fire stop.

7.5.10 The fire-endurance rating of the horizontal fire-separating element shall be equal to or greater than the intended fire-endurance of the grease duct enclosure system and the through-penetration fire stop.

7.5.11 Install the enclosure material using the test sponsor's installation instructions documented in 7.4. The space created around the vertical grease duct section and the horizontal fire-separating element shall be sealed with a through-penetration fire-stop system specified by the test sponsor. Install through-penetration fire stop in accordance with the test sponsor's instructions. Document the test sponsor's through-penetration fire-stop system and its method of installation.

7.5.12 Construct an access opening, as documented in 7.4, on the side of the grease duct between the internal thermocouples and the vertical leg of the grease duct. Document the access opening construction, location, and size.

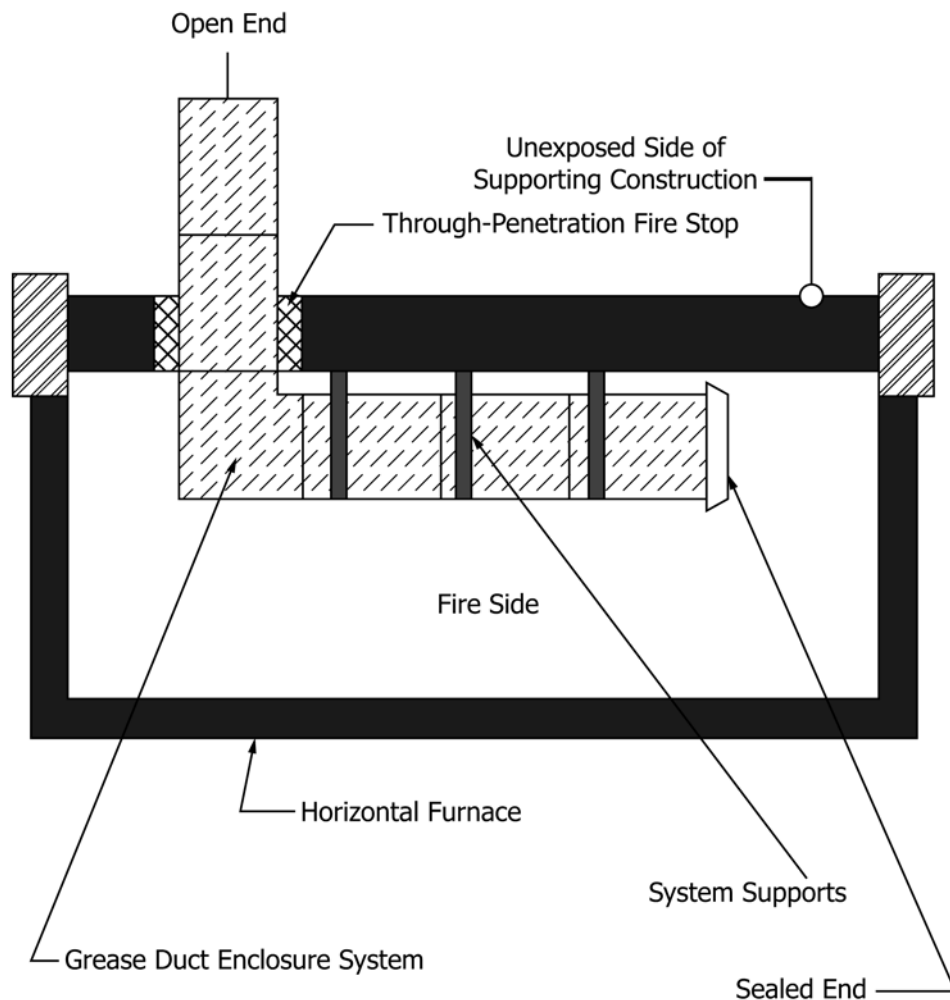

FIG. 8 Fire-Engulfment Test Arrangement

7.5.13 Install the test assembly in a horizontal furnace capable of attaining the standard fire exposure conditions required by Test Methods E119 and E814. Center the test assembly in the furnace. Maintain a minimum distance of 12 in. (305 mm) between the grease duct enclosure system and the furnace walls.

**8. Preparation of Apparatus**

8.1 *Noncombustibility Test*—Prepare the apparatus in accordance with Test Method E136.

8.2 *Fire Resistance Test*—Prepare the vertical furnace in accordance with Test Methods E119, reference 6.3 and Fig. 2.

8.3 *Durability Test*—Prepare the apparatus in accordance with Test Method C518.

8.4 *Internal Fire Test*—Prepare a combustion chamber and gas-fired burners as referenced in 6.1 and 6.2, respectively, and Fig. 1.

8.4.1 Fire Side Thermocouples

8.4.1.1 Locate four fire side thermocouples (1 through 4) inside the grease duct referenced in 14.1 as illustrated in Fig. 7, Fig. 9 and Fig. 10. Measure the internal temperature in the grease duct’s orifice at its mid-length. Position the fire side thermocouples either a minimum of 12 in. (305 mm) from each internal surface of the grease duct exposed to fire, or one-fourth of the distance between the parallel opposing internal surfaces of the grease duct exposed to fire, whichever is less.

8.4.1.2 Fire side thermocouples shall not be heavier than No. 18 Type S or K (0.040 in.) [1.02 mm] or shall be 1/16-in. diameter (1.6 mm) Inconel® stainless steel-sheathed. When used in a furnace, fire side thermocouples shall project 1/2 ± 1/16 in. (12.7 mm) from the inner ends of support tubes.

8.5 *Fire-Engulfment Test*—Prepare the horizontal furnace in accordance with Test Methods E119, reference 6.3 and Fig. 3.

**9. Calibration and Standardization**

9.1 When calibration procedures are specified in the Test Methods referenced in these test methods, follow those calibration procedures.

9.2 Prior to performing the tests, the following devices shall be calibrated or their calibration shall be verified:

- 9.2.1 The thermocouple wire,
- 9.2.2 The data acquisition equipment, and
- 9.2.3 The pressure gage or similar device used to monitor gas flow.

**10. Conditioning**

10.1 *Noncombustibility Test Specimen Conditioning*—Refer to and follow protocols in Test Method E136.

10.2 *Fire Resistance Test Specimen Conditioning*—Refer to and follow protocols in Test Methods E119.

10.3 *Durability Test Specimen Conditioning*—Refer to and follow protocols in Test Method C518.

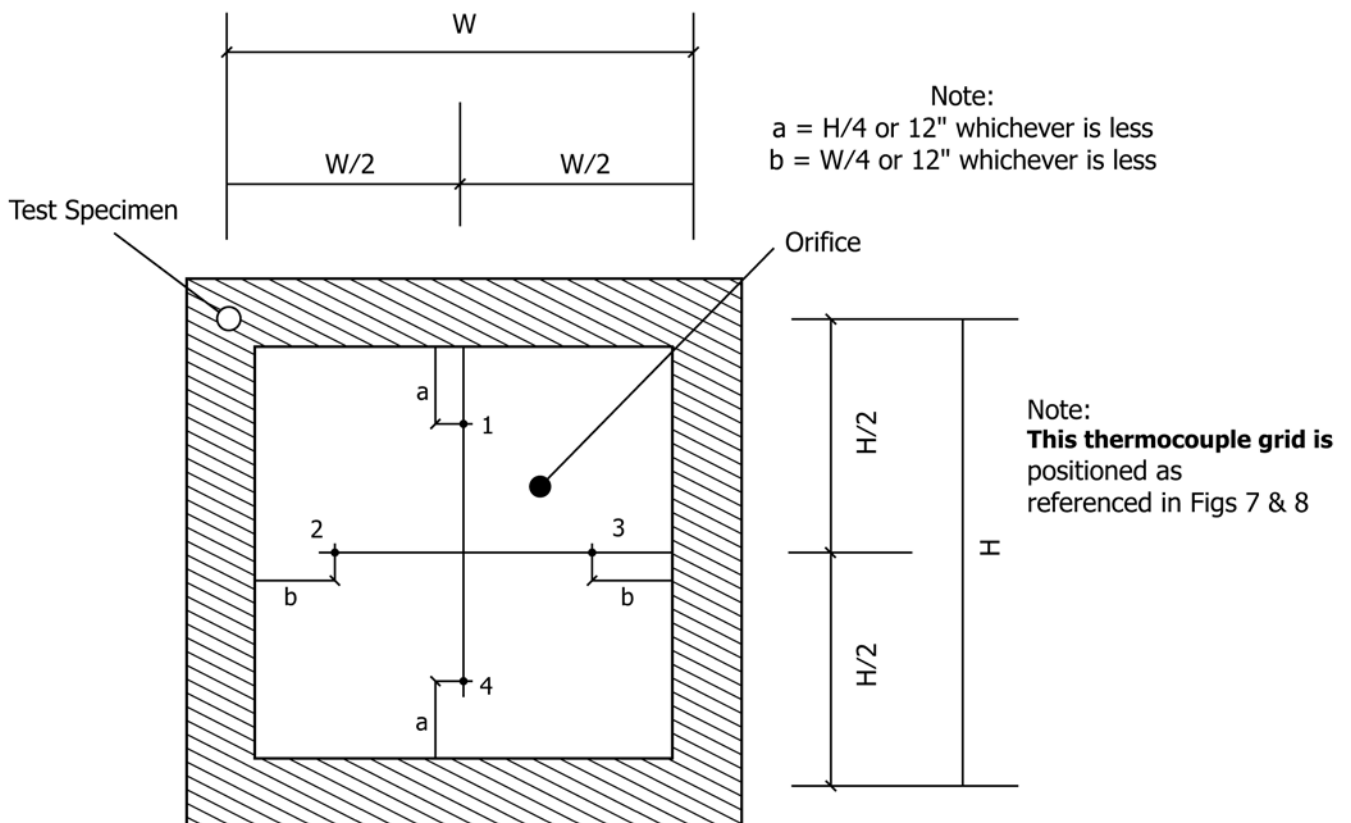

FIG. 9 Exposed (Fire Side/Internal) Thermocouple Locations

Note: All dimensions are in inches with a tolerance of -5% unless otherwise noted.

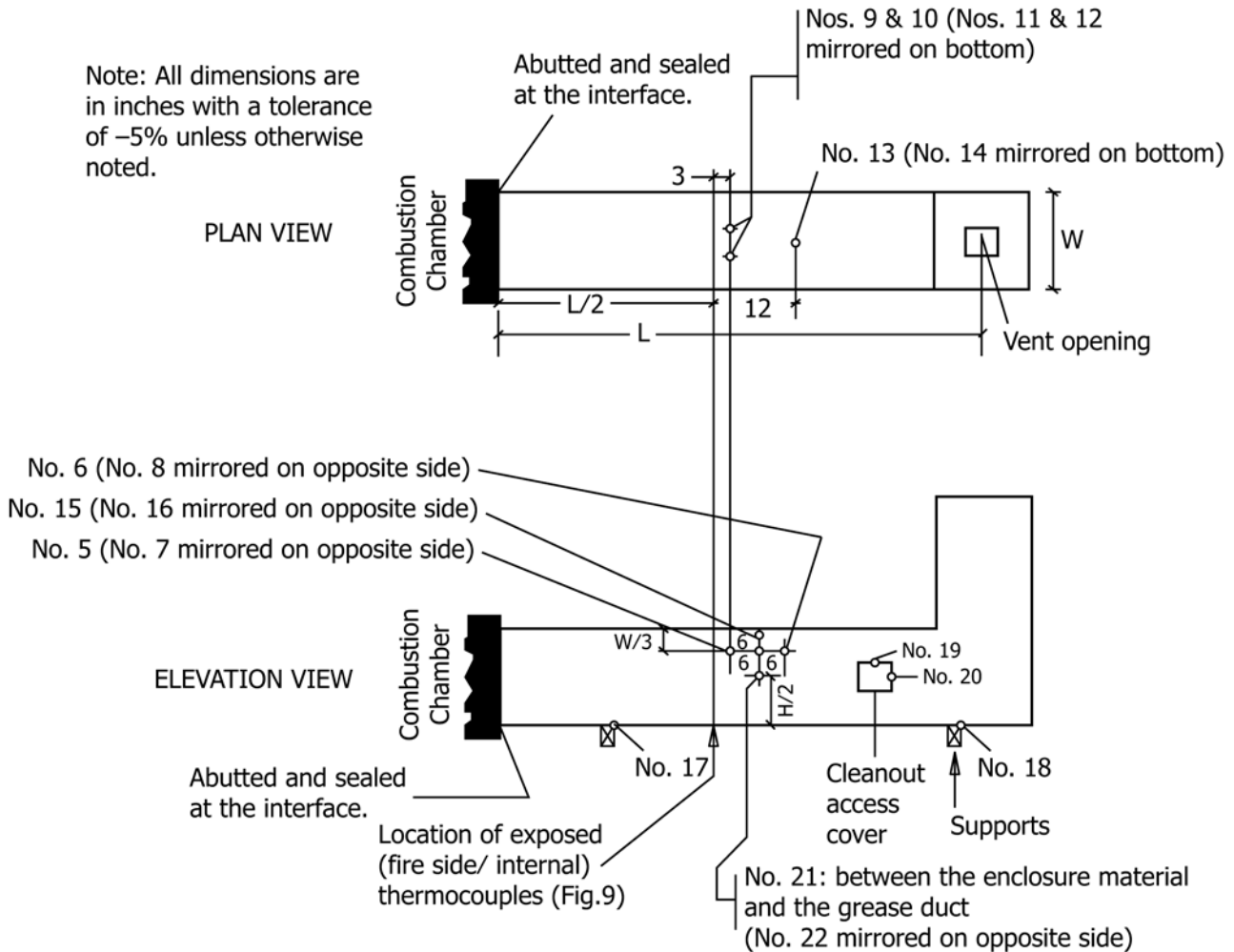

FIG. 10 Unexposed Surface Thermocouple Locations

10.4 *Internal Fire Test Specimen Conditioning*—Refer to and follow protocols in Test Methods E119.

10.5 *Fire-Engulfment Test Specimen Conditioning*—In addition to the requirements in 10.4, follow protocols in Test Method E814.

## 11. Noncombustibility Test Procedures

11.1 Test the test specimen in accordance with the requirements of Test Method E136.

11.2 Document information required by Test Method E136.

## 12. Fire Resistance Test Procedures

12.1 Test, for a period of time specified by the test sponsor, the test assembly in accordance with Test Methods E119 using a vertical furnace. Document the specified duration of the fire test exposure.

### 12.2 Unexposed Surface Thermocouples

12.2.1 Record temperatures at not fewer than nine points on unexposed side of the test assembly. Thermocouple pads shall be required to cover each of the unexposed surface thermocouples. Use the unexposed surface thermocouples referenced in 6.6 covered by the thermocouple pads referenced in 6.7.

12.2.2 Install the unexposed surface thermocouples in conformance with Test Methods E119 on the unexposed side of the test assembly.

12.2.3 Symmetrically locate five of the unexposed surface thermocouples as follows:

12.2.3.1 Center one unexposed surface thermocouple on the test assembly, and

12.2.3.2 Symmetrically divide the surface area of the test assembly into four equal square quadrants and center one unexposed surface thermocouple in each quadrant.

12.2.3.3 Locate at least four more unexposed surface thermocouples on the test assembly to obtain representative information on the performance of the test assembly, including one unexposed surface thermocouple located at the geometric center of the clean-out opening.

12.2.4 Do not locate the unexposed surface thermocouples closer to the edges of the test assembly than 12 in. (305 mm), unless an element of the test assembly is not otherwise represented in the remainder of the test assembly.

12.3 Start and continue the fire-endurance test until failure occurs as defined by Test Methods E119, or until the period of time specified in 12.1 is met.

12.4 Document information required by Test Methods E119.

12.5 At the request of the test sponsor, continue the test beyond the time specified in 12.1.

NOTE 14—Often the purpose in continuing the test beyond the time specified in the Conditions of Compliance is to obtain additional data.

12.6 Apply the hose stream test to the fire side of the test assembly in conformance with Test Methods E119. Document the results of the hose stream test.

### 13. Durability Test Procedure

13.1 Test four test specimens in accordance with Test Method C518 and use the data as a base reference for comparison to the temperature transmission data acquired on the temperature aged test specimens in 13.2 to determine changes, if any, in thermal transmission properties.

13.2 Test another four test specimens in accordance with Test Method C518 with the following modifications:

13.3 Place the test specimens on a rack in a vertical position, with a clearance between each test specimen of  $\frac{3}{8}$  to  $\frac{3}{4}$  in. (9.5 to 19.1 mm).

13.4 Place the rack into an oven that has been preheated to a temperature of 300°F (149°C).

13.5 After 12 h  $\pm$  5 min, shut off the oven and allow the test specimens to cool for 12 h  $\pm$  5 min.

13.6 Repeat this cycle 10 times.

13.7 On completion of the final cycle, remove the test specimens from the oven and allow them to cool for a period of 2 h  $\pm$  5 min at standard atmospheric conditions.

NOTE 15—The intent of this temperature aging test is to simulate the effects of long-term exposure of typical in-service conditions on the thermal transmission qualities of the enclosure materials.

13.8 Document information required by Test Method C518 for all eight of the test specimens.

### 14. Internal Fire Tests

14.1 *Test Assembly*—Conduct an internal fire test on the test specimen (a grease duct protected with the enclosure material).

NOTE 16—When seeking approval from some evaluation services, the grease duct construction should comply with the minimum requirements of NFPA 96. The International Mechanical Code (IMC) also provides minimum requirements for the construction of grease ducts, similar to NFPA 96.

14.2 Conduct this test so that the environmental conditions, such as air temperature and air velocity at time of test, shall comply with Test Methods E119.

#### 14.3 Unexposed Surface Temperatures

14.3.1 Use the unexposed surface thermocouples referenced in 6.6 covered by the thermocouple pads referenced in 6.7.

14.3.2 Install the unexposed surface thermocouples covered by thermocouple pads in conformance with Test Methods E119.

14.3.3 Thermocouple locations shall be determined by the laboratory to represent the locations least resistant to thermal transmission, and shall be located following the guidelines illustrated in Fig. 10, and as follows:

14.3.3.1 Install at least 16 unexposed surface thermocouples (5 through 20) as follows:

NOTE 17—Thermocouples numbered 1-4 are the fire side thermocouples described in 8.4.1.1 and referenced in Fig. 6.

14.3.3.2 Position two unexposed surface thermocouples on each of the four unexposed faces (top, bottom, left, and right sides) of the longitudinal section of the test assembly. Use a total of eight unexposed surface thermocouples (5 through 12).

14.3.3.3 Position two unexposed surface thermocouples (13 and 14) on the unexposed side over transverse overlaps or butt joints of the enclosure materials.

14.3.3.4 Position two unexposed surface thermocouples (15 and 16) on the unexposed side over longitudinal overlaps or butt joints of the enclosure materials.

14.3.3.5 Position two unexposed surface thermocouples (17 and 18) between the exterior surface of the grease duct enclosure system and the support system, for informational purposes only.

14.3.3.6 Position two unexposed surface thermocouples (19 and 20) around the edges of the clean-out access cover: put one on the top and one on the side of the access cover at the joints between the access cover and the enclosure material.

14.3.3.7 When requested by the test sponsor, sandwich two unexposed surface thermocouples (21 and 22) between the unexposed sides of the grease duct and the inside face of the enclosure material, for informational purposes only.

#### 14.4 Conduct of Test:

14.4.1 Simultaneously start the gas-fired burners, measuring devices and data acquisition equipment.

14.4.2 Use the fire side thermocouples (1 through 4) to monitor the temperature inside the mid-length of the test assembly at all times during the interior fire test.

14.4.3 Adjust the burner's fuel supply to increase the average temperature inside the test assembly from room temperature to at least 500°F (260°C) within 15 min.

14.4.4 Maintain this minimum 500°F (260°C) average interior temperature for at least 4 h.

14.4.5 Record data at maximum 5-min intervals during the next 4 h of the test.

14.4.6 Within 15 min after the end of the 4-h period, adjust the burner's fuel supply to increase the average interior temperature to at least 2000°F (1093°C).

14.4.7 Maintain the minimum 2000°F (1093°C) average temperature for the next 30 min of the test.

14.4.8 Temperatures shall be recorded at intervals not exceeding 30 s during the 30-min exposure period.

### 15. Fire Engulfment Test Procedure

15.1 Use the time specified by the test sponsor documented in 12.1 to expose the test assembly to fire-exposure conditions in accordance with Test Methods E119 using a horizontal furnace and test assembly.

15.2 Thermocouple the through-penetration fire-stop in accordance with Test Method E814.

15.3 When requested by the test sponsor, sandwich two unexposed surface thermocouples between the unexposed side of the grease duct and the inside face of the enclosure material,



one-half the distance down the length of the horizontal section of duct, at its mid-height, for informational purposes only.

15.4 Start and continue the fire-endurance test until failure occurs as defined by Test Methods **E119**, or until the period of time specified in **12.1** has expired. Perform the fire engulfment test in accordance with Test Methods **E119** with the following modifications.

15.4.1 Expose the test assembly to fire-exposure conditions in accordance with Test Methods **E119** and **E814** using the furnace pressure conditions of Test Method **E814**.

15.4.2 Record data as required in accordance with Test Methods **E119** and **E814**. The fire resistance test shall be continued until failure occurs as described in Test Methods **E119** and **E814** or until the assembly has sustained the test conditions for the specified period of time.

15.4.3 After fire engulfment test, subject the fire side of the test assembly to the hose stream test provisions specified in Test Method **E814**.

15.5 Document information required by Test Methods **E119** and **E814**.

15.6 At the request of the test sponsor, continue the test beyond the time specified in **12.1**.

NOTE 18—Often the purpose in continuing the test beyond the time specified in the Conditions of Compliance is to obtain additional data.

## 16. Conditions of Compliance

16.1 *Noncombustibility Test*—The test specimen shall meet the passing requirements of Test Method **E136**.

### 16.2 *Fire Resistance Test*

16.2.1 The test assembly is required to conform to the Conditions of Compliance of Test Methods **E119**. The period of time at which this occurs shall be documented.

16.2.2 The test assembly is required to pass the hose-stream test specified in Test Methods **E119**.

### 16.3 *Durability Test*

16.3.1 The average thermal conductivity of the temperature aged test specimens shall not be greater than 110 % of the average thermal conductivity of the control test specimens.

### 16.4 *Internal Fire Test*

16.4.1 Transmission of heat through the test specimen shall not raise the temperature of any individual unexposed surface thermocouple more than 117°F (65°C) above its initial temperature when the minimum average temperature inside the grease duct is 500°F (260°C).

16.4.2 When the minimum average temperature inside the grease duct is 2000°F (1093°C), the transmission of heat through the test specimen shall not raise:

16.4.2.1 The average temperature of the unexposed surface thermocouples more than 250°F (139°C) above their initial average temperature, or

16.4.2.2 The temperature of any individual unexposed surface thermocouple more than 325°F (181°C) above its initial temperature.

16.4.3 The enclosure material shall remain in place without the occurrence of openings.

16.4.4 No flaming shall occur on the unexposed side of the test specimen during the classification period with the following exceptions:

16.4.4.1 During the first 5 min of the test, flaming at any one location for a cumulative total of less than 10 s is permitted at overlaps or butt joints of the grease duct enclosure system only.

16.4.4.2 After the first 5 min of the test, flaming at any one location for a cumulative total of less than 10 s is permitted at overlaps or butt joints of the grease duct enclosure system only.

16.4.4.3 Flaming at the inlet and outlet of the test specimen is also permitted.

## 16.5 *Fire-Engulfment Test*

16.5.1 The test specimen shall sustain the test conditions and conform with the Conditions of Compliance of Test Methods **E119** and **E814** for a period of time equal to that specified by the test sponsor in **12.1**. There shall be no opening into the grease duct orifice during the fire-engulfment test or during the hose stream test.

16.5.2 The penetration fire-stop shall comply with the F-Rating requirements of Test Method **E814** for the same period of time as the fire engulfment test.

16.5.3 For horizontal penetrations, the penetration fire-stop shall comply with the T-Rating requirements of Test Method **E814** for the same period of time as the fire engulfment test.

## 17. Report

17.1 Report the details of all test specimens and the construction of test assemblies.

17.2 Report the description (including whether or not the material is faced) density and dimensions of all test specimens tested.

17.3 *Noncombustibility Test*—Report information in accordance with Test Method **E136**, and whether or not the test specimen met the Conditions of Compliance in **16.1**.

17.4 *Fire Resistance Test*—Report information in accordance with Test Methods **E119**, and whether or not the test specimen met the Conditions of Compliance in **16.2**.

17.5 *Durability Test*—Report information in accordance with Test Method **C518**, and the percent increase in thermal conductivity as determined in accordance with **16.3.1**, and whether or not the test specimen met the Conditions of Compliance in **16.3**.

17.6 *Internal Fire Test*—Report the following information:

17.6.1 The rise in temperature of all unexposed surface thermocouples referenced in **14.3** after the interior temperature has been maintained at 500°F (260°C) for at least 4 h in accordance with **14.4.3 – 14.4.5**, and whether or not the test specimen met the Conditions of Compliance in **16.4.1**.

17.6.2 The rise in temperature of all unexposed surface thermocouples referenced in **14.3** after the interior temperature has been maintained at 2000°F (1093°C) for at least 30 min in accordance with **14.4.6 – 14.4.8**, and whether or not the test specimen met the Conditions of Compliance in **16.4.2**.

17.6.3 Whether or not the test specimen met the Conditions of Compliance in **16.4**.

17.7 *Fire-Engulfment Test*—Report information in accordance with Test Methods **E119** and **E814**, the test specimen, and through penetration fire stop ratings as determined by the Conditions of Compliance in **16.5**.

17.8 Report all other information required to be documented by this standard.

## **18. Precision and Bias**

18.1 *Noncombustibility Test*—Refer to Test Method **E136**.

18.2 *Fire resistance Test*—Refer to Test Methods **E119**.

18.3 *Durability Test*—Refer to Test Method **C518**.

18.4 *Internal Fire Test*—No information is presented about either the precision or bias of this test method for measuring the response of enclosure materials to a standard internal fire test under controlled laboratory conditions because no material having an acceptable reference value has been determined.

18.5 *Fire-Engulfment Test*—Refer to Test Methods **E119** and **E814**.

## **19. Keywords**

19.1 enclosure material; engulfment test; fire-resistive; fire separating elements; grease duct; grease duct enclosure system; hose stream; internal fire test

*ASTM International takes no position respecting the validity of any patent rights asserted in connection with any item mentioned in this standard. Users of this standard are expressly advised that determination of the validity of any such patent rights, and the risk of infringement of such rights, are entirely their own responsibility.*

*This standard is subject to revision at any time by the responsible technical committee and must be reviewed every five years and if not revised, either reapproved or withdrawn. Your comments are invited either for revision of this standard or for additional standards and should be addressed to ASTM International Headquarters. Your comments will receive careful consideration at a meeting of the responsible technical committee, which you may attend. If you feel that your comments have not received a fair hearing you should make your views known to the ASTM Committee on Standards, at the address shown below.*

*This standard is copyrighted by ASTM International, 100 Barr Harbor Drive, PO Box C700, West Conshohocken, PA 19428-2959, United States. Individual reprints (single or multiple copies) of this standard may be obtained by contacting ASTM at the above address or at 610-832-9585 (phone), 610-832-9555 (fax), or [service@astm.org](mailto:service@astm.org) (e-mail); or through the ASTM website ([www.astm.org](http://www.astm.org)). Permission rights to photocopy the standard may also be secured from the Copyright Clearance Center, 222 Rosewood Drive, Danvers, MA 01923, Tel: (978) 646-2600; <http://www.copyright.com/>*