



Standard Test Method for Insulating Glass Unit Performance¹

This standard is issued under the fixed designation E2188; the number immediately following the designation indicates the year of original adoption or, in the case of revision, the year of last revision. A number in parentheses indicates the year of last reapproval. A superscript epsilon (ϵ) indicates an editorial change since the last revision or reapproval.

1. Scope

1.1 This test method covers procedures for testing the performance of preassembled permanently sealed insulating glass units or insulating glass units with capillary tubes intentionally left open.

1.2 This test method is applicable only to sealed insulating glass units that are constructed with glass.

1.3 This test method is applicable to both double-glazed and triple-glazed insulating glass units. For triple-glazed insulating glass units where both of the outer lites are glass and the inner lite is either glass or a suspended film.

1.4 The unit construction used in this test method contains dimensions that are an essential component of the test. Different types of glass, different glass thicknesses, and different airspace sizes may affect the test results.

1.5 This test method is not applicable to sealed insulating glass units containing a spandrel glass coating due to testing limitations.

1.6 The values stated in SI units are to be regarded as standard. No other units of measurement are included in this standard.

1.7 *This standard does not purport to address all of the safety concerns, if any, associated with its use. It is the responsibility of the user of this standard to establish appropriate safety and health practices and determine the applicability of regulatory limitations prior to use.*

2. Referenced Documents

2.1 *ASTM Standards:*²

[C162 Terminology of Glass and Glass Products](#)

[C717 Terminology of Building Seals and Sealants](#)

[C1036 Specification for Flat Glass](#)

¹ This test method is under the jurisdiction of ASTM Committee E06 on Performance of Buildings and is the direct responsibility of Subcommittee E06.22 on Durability Performance of Building Constructions.

Current edition approved Nov. 1, 2010. Published February 2011. Originally approved in 2002. Last previous edition approved in 2002 as E2188 – 02. DOI: 10.1520/E2188-10.

² For referenced ASTM standards, visit the ASTM website, www.astm.org, or contact ASTM Customer Service at service@astm.org. For *Annual Book of ASTM Standards* volume information, refer to the standard's Document Summary page on the ASTM website.

[E631 Terminology of Building Constructions](#)

[E546 Test Method for Frost/Dew Point of Sealed Insulating Glass Units](#)

[E2190 Specification for Insulating Glass Unit Performance and Evaluation](#)

3. Terminology

3.1 *Definition of Terms:*

3.1.1 For definitions of terms found in this standard, refer to Terminologies [C162](#), [C717](#), and [E631](#).

3.2 *Definitions of Terms Specific to This Standard:*

3.2.1 *frost/dew point, n*—the temperature at which water, organic vapor, or other chemicals begin to appear on the interior glass surface of a sealed insulating glass unit.

4. Significance and Use

4.1 This test method is intended to provide a means for testing the performance of the sealing system and construction of sealed insulating glass units.

4.1.1 Sealed insulating glass units tested in accordance with this method may be suitable for structurally glazed applications. However, factors such as sealant longevity when exposed to long term ultraviolet light and the structural properties of the sealant must be reviewed for these applications.

4.1.2 Sealed insulating glass units tested in accordance with this method are not intended for continuous exposure to high relative humidity conditions or long-term immersion in water.

5. Test Specimens

5.1 Each test specimen shall measure 355 ± 6 mm by 505 ± 6 mm and shall be composed of two or three lites of clear, tinted or coated annealed, heat-strengthened, tempered, or laminated glass.

5.1.1 The double-glazed test samples shall be fabricated with at least one lite of clear, uncoated glass. The triple-glazed test samples shall be fabricated with at least one outer lite of clear, uncoated glass. The other outer lite shall be fabricated with a glass which allows easy viewing of the frost point.

5.1.2 The thickness of the glass lites shall be between nominal 3.0 mm and a maximum of 6.0 mm nominal.

5.1.3 The airspaces for units with either two or three lites of glass shall be a minimum of 6.0 ± 0.8 mm.

5.1.4 When testing to Specification [E2190](#) the specimen construction shall be as defined in that document.

5.1.5 Triple-pane units where the intermediate airspace divider is a plastic film are acceptable.

NOTE 1—Overall unit thickness has some limits. Testing laboratories are usually able to accommodate 30 mm overall thickness. If testing thicker units, contact the testing laboratory prior to manufacturing to ascertain their capabilities for testing thicker units.

5.2 The thickness tolerance of the glass shall conform to Specification C1036.

5.3 Each specimen shall be permanently and legibly marked with the designation of the manufacturer, the date of fabrication (month or quarter and year) and orientation intended in the field (for units constructed with coated glass).

5.4 At least nine specimens of identical component materials and construction shall be submitted for testing.

5.5 During all stages of exposure and storage, the units shall be held in a vertical position with equal support to all panes and no compression loading.

5.6 Selection of six specimens for testing shall be made at random from the submitted specimens except for specimens damaged in transit. Damaged specimens shall not be tested.

5.7 Test specimens representing insulating glass units that will be gas filled shall be fabricated using the same hole sealing and gas filling techniques as those used for manufacturing. For example, if a gas-filling plug is used in manufacturing then it must be used in the test units. The samples do not need to be filled with gas providing that the gas is classified as inert. Test samples representing products that are normally filled with an inert gas in production, may be submitted air filled for this

testing as long as they have been manufactured with the same techniques as used in production.

5.8 Test specimens representing insulating glass units that include tubes intended to be left open shall be fabricated with one tube. These tubes shall be left open during testing. Test samples representing units that include tubes intended to be closed off after shipping shall be fabricated with one tube. These tubes shall be closed at the exterior end prior to testing.

6. Apparatus

6.1 For Weather Cycle Phase:

6.1.1 Weather Cycle Test Apparatus³—The weather cycle test apparatus shall be essentially that shown in Figs. 1 and 2 to provide the required test conditions indicated in Section 8. Modifications to this test apparatus are acceptable providing that the required test conditions are met.

6.1.1.1 Ultraviolet Light Source —(Warning—Ultraviolet light sources used in this test method are harmful, especially to the eyes. Appropriate protective measures must be observed.)

6.1.1.2 The source shall consist of two fluorescent ultraviolet lamps, Type F72T12BL/HO⁴ (Note 2), for each test specimen located as shown in Fig. 1.

³ The apparatus is a modification of the device developed by the Institute for Research in Construction (IRC) of the National Research Council of Canada. One modification was to expose each test specimen to two ultraviolet lamps.

⁴ Available from General Electric Company (GE), Nela Park, Cleveland, OH 44112, <http://www.ge.com>.

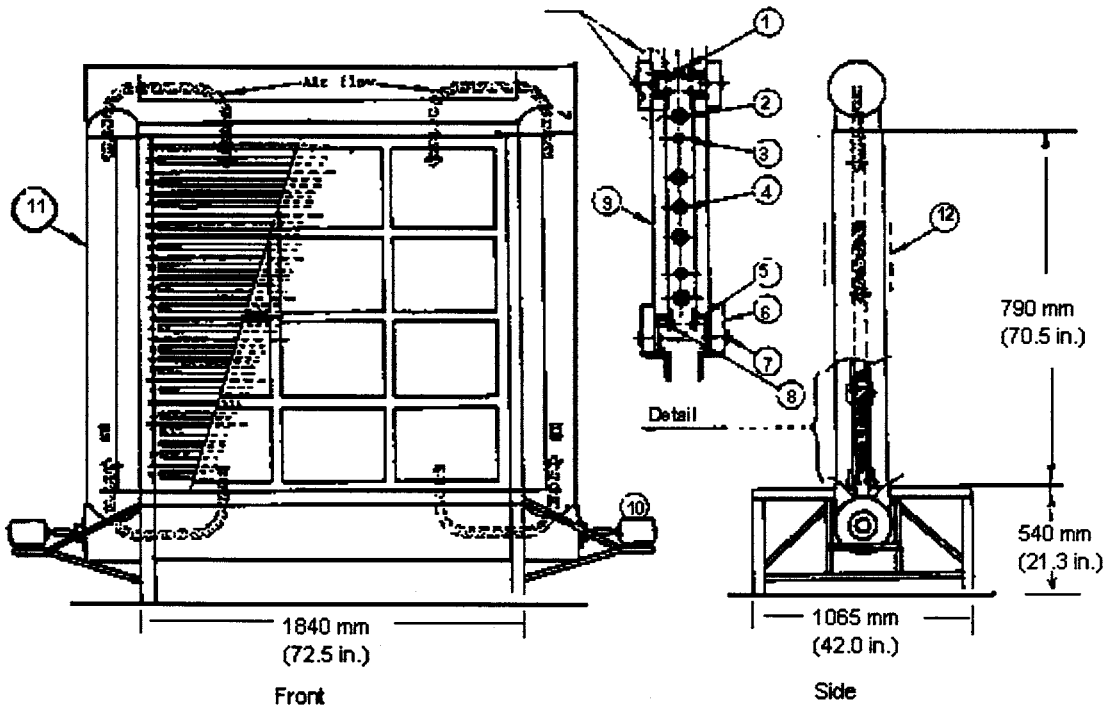

Description: (1) Fog or mist spray; (2) Cooling coil; (3) Fluorescent ultraviolet lamp, F72T12BL/HO; (4) Heating coil; (5) Rubber pad; (6) Polystyrene insulation; (7) Rubber washer; (8) Clamping device; (9) Test specimen; (10) Fan motor; (11) Air duct; (12) Insulation

FIG. 1 Schematic Drawing of Typical Accelerated Weathering Apparatus

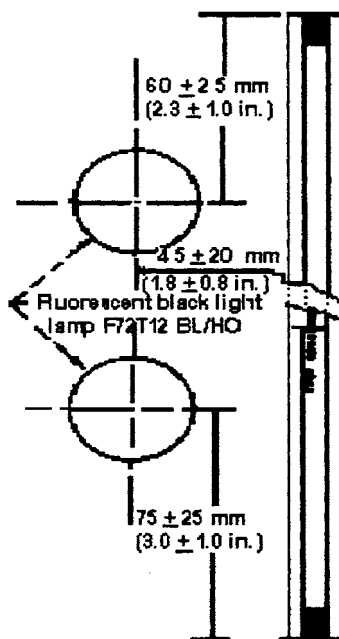

FIG. 2 Location of Fluorescent Ultraviolet Lamp Relative to the Test Specimen

NOTE 2—Rated average life at 3 h per start: 12 000 h. Rated average life at 12 h per start: 18 000 h. Useful length: 1625 mm. Wattage: 85 W. Relative ultraviolet energy output is 190 % that of F40BL lamp (not high output), when measured at 340 nm.

6.1.1.3 Each lamp shall be replaced when its ultraviolet light intensity falls below 10 W/m^2 ($1000 \mu\text{W/cm}^2$) when measured with a long-wave ultraviolet meter⁵ in direct contact with the lamp.

6.1.2 Protect the accelerated weathering chamber from overheating and from overcooling with protective devices.

6.1.3 Equip the accelerated weather cycle chamber with one or more sensors and a continuous temperature recording device placed in an area that measures the representative air temperature at any time inside the chamber.

6.2 For High Humidity Phase:

6.2.1 *High Humidity Test Chamber*—A chamber of convenient dimensions capable of maintaining $60 \pm 3^\circ\text{C}$ and $95 \pm 5\%$ relative humidity.

6.2.2 The high humidity chamber shall be protected from overheating with a protective device.

6.2.3 Equip high humidity chamber with one or more sensors and a continuous air temperature-recording device placed in an area that monitors the average temperature in the chamber.

7. Preparation of Test Specimens

7.1 Uncleanable stain or scum may remain on the exterior glass surface of the specimen after the accelerated weathering test. Measures shall be taken to have a clear view of the interior

glass surface for detection of frost. For example, place a mask of plastic tape⁶ 50 by 50 mm or larger, on the central region of both exterior glass surfaces before exposing the unit to weathering conditions. Remove the mask for frost/dew point measurement.

7.2 The sealed insulating glass units shall be sealed a minimum of 4 weeks from date of manufacture to allow for stabilization before testing. The manufacturer shall be permitted to waive this requirement.

8. Procedure for Seal Durability

8.1 Initial Frost/Dew Point Test:

8.1.1 Determine the initial frost/dew point on all airspaces on all units submitted using Test Method E546 or equivalent.

8.2 High Humidity Phase:

8.2.1 Place the test specimens that were tested in accordance with 8.1 in the high humidity test apparatus. Expose six specimens in the high-humidity test chamber at $60 \pm 3^\circ\text{C}$ and $95 \pm 5\%$ relative humidity. Arrange the specimens so that each specimen has at least 6 mm clearance all around.

8.2.2 When the specified time period (days) has been attained,⁷ remove the test specimens. Allow the test specimens to equilibrate at $23 \pm 3^\circ\text{C}$ for not less than 24 h. Determine the frost/dew point in accordance with Test Method E546 or equivalent. For triple-pane units, the frost/dew point shall be determined for all airspaces. If liquid appears, record the temperature at which it occurs.

⁵ The only suitable meter is the Blak-Ray UV Meter with J221 sensor cell. The sole source of supply of the apparatus known to the committee at this time is UVP, LLC, 2066 West 11th Street, Upland, CA 91786. If you are aware of alternative suppliers, please provide this information to ASTM International Headquarters. Your comments will receive careful consideration at a meeting of the responsible technical committee,¹ which you may attend.

⁶ Scotch Plastic Tape #471 available from 3M Company, 3M Center, Commercial Office Supply Division, Bldg. 230-3 South-17, St. Paul, MN 55101, has been found suitable for this purpose.

⁷ The amount of time under the high humidity test condition is optional and is at the discretion of the test specifier. When testing to Specification E2190, the amount of time required is specified in that document.

8.3 Weather Cycle Phase:

8.3.1 Place the six test specimens tested in accordance with 8.1 and 8.2 in the weather cycle chamber. Mount the specimens so that one exterior surface of the specimen is exposed to the weather cycles and the other to room temperature ($23 \pm 3^\circ\text{C}$). Install all specimens as shown in Fig. 1, taking care that no stress is induced in the test specimens by the method of fastening.

8.3.2 The test specimens shall be oriented in the weather cycle chamber with the number one surface facing the weather changes as it does in normal field exposure.

8.3.3 Cycling—Each cycle shall be 6 h \pm 5 min and composed of the following test conditions (see Fig. 3):

8.3.3.1 During the first 60 \pm 5 min, decrease the air temperature from room temperature to $-29 \pm 3^\circ\text{C}$.

8.3.3.2 Maintain air temperature at $-29 \pm 3^\circ\text{C}$ for 1 h \pm 5 min.

8.3.3.3 Control the air temperature rise from $-29 \pm 3^\circ\text{C}$ to room temperature over a period of 60 \pm 5 min. Use the heat source as needed.

8.3.3.4 Start the ultraviolet lamps and over a time period of 60 \pm 5 min control the temperature rise from room temperature to $60 \pm 3^\circ\text{C}$. At the beginning of this same 60 min period, turn on water or mist supply. The interior of the chamber, at the test specimens, shall achieve a minimum of 90 % relative humidity (RH) within this time period. It is not necessary to stay at or above 90 % RH as long as the environment achieves 90 % RH sometime in this 60 min time.

8.3.3.5 Turn off the water or mist supply after 60 min.

8.3.3.6 Maintain temperature at $60 \pm 3^\circ\text{C}$ and continue ultraviolet exposure for a period of 60 \pm 5 min.

8.3.3.7 Over a period of 60 \pm 5 min, decrease temperature from $60 \pm 3^\circ\text{C}$ to room temperature, and continue ultraviolet exposure. At the end of this period, turn off ultraviolet lamp.

8.3.3.8 When the specified number of cycles has been attained,⁸ remove the test specimens. Allow the test specimens to equilibrate at $23 \pm 3^\circ\text{C}$ for not less than 24 h. Determine the frost/dew point in accordance with Test Method E546 or equivalent. For triple-pane units, the frost/dew point shall be determined for all airspaces. If liquid appears, record the occurrence.

9. Measurements and Observations

9.1 Observe the following:

9.1.1 Glass breakage.

9.1.2 Any visible deposit in the airspace.

9.2 Measure the following:

9.2.1 Measure the frost/dew point of each insulating glass unit.

10. Report

10.1 Complete Description of Specimen Tested:

10.1.1 Dimensions of the test specimen (width by height) and overall thickness.

10.1.2 Type and thickness of glass.

10.1.3 Glass coatings and surface locations if applicable.

10.1.4 Airspace thickness(es).

10.1.5 Spacer composition(s) and configuration(s).

10.1.6 Corner construction.

10.1.7 Type and number of spacer connecting methods/components.

10.1.8 Desiccant type and quantity, if provided.

10.1.9 Presence and type of tube, if applicable.

⁸ The number of cycles is optional and is at the discretion of the test specifier. When testing to Specification E2190, the number of cycles is specified in that document.

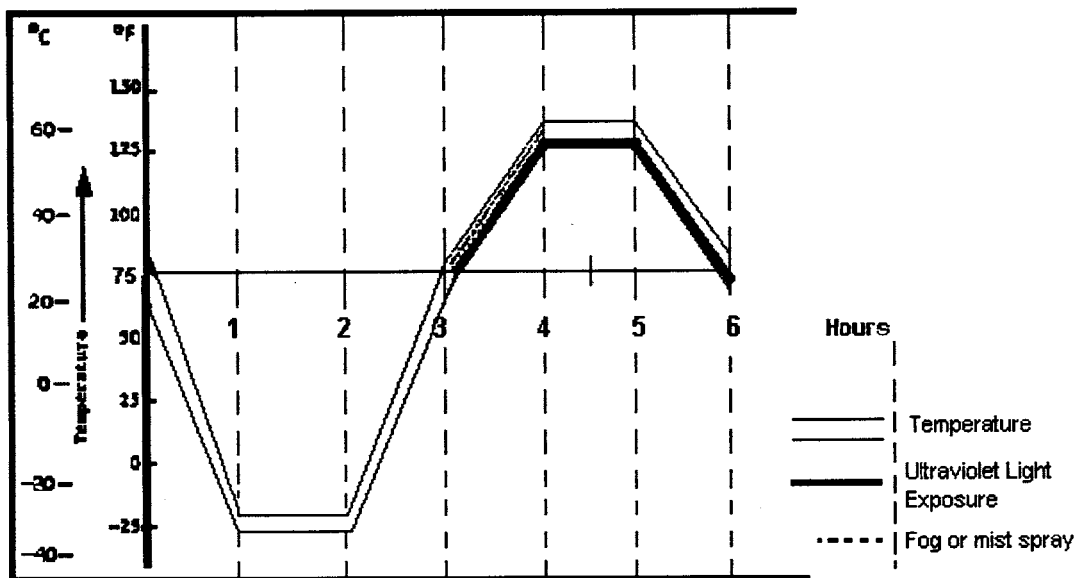

NOTE 1—This figure represents the ideal cycle described in this test method. Any temperature variation within the tolerance zone shown is acceptable.

FIG. 3 Schematic Drawing of Each Cycle for Accelerated Weather Cycle Test

- 10.1.10 Presence and type of gas fill plug, if applicable.
- 10.1.11 Sealant type(s) and dimensions, if provided.
- 10.1.12 Manufacturer and manufactured date (month or quarter, if known, and year).
- 10.2 *Duration of Test:*
 - 10.2.1 Duration of high humidity phase described in 8.2 (number of days).
 - 10.2.2 Duration of accelerated weather cycle phase described in 8.3 (number of cycles).
 - 10.2.3 Duration of any additional testing including type and order of testing and number of cycles or days.
- 10.3 Glass breakage, if observed.

- 10.4 Frost/dew point of each unit after testing to 8.1-8.3, if observed.
- 10.5 Any visible deposit(s) in the airspace.

11. Precision and Bias

11.1 *Precision and Bias*—The precision and bias of this test method for measuring the frost/dew point of insulating glass durability performance are essentially as specified in Test Method E546.

12. Keywords

12.1 IGU performance; IGU seal durability; insulating glass units (IGU); sealed insulating glass units

ASTM International takes no position respecting the validity of any patent rights asserted in connection with any item mentioned in this standard. Users of this standard are expressly advised that determination of the validity of any such patent rights, and the risk of infringement of such rights, are entirely their own responsibility.

This standard is subject to revision at any time by the responsible technical committee and must be reviewed every five years and if not revised, either reapproved or withdrawn. Your comments are invited either for revision of this standard or for additional standards and should be addressed to ASTM International Headquarters. Your comments will receive careful consideration at a meeting of the responsible technical committee, which you may attend. If you feel that your comments have not received a fair hearing you should make your views known to the ASTM Committee on Standards, at the address shown below.

This standard is copyrighted by ASTM International, 100 Barr Harbor Drive, PO Box C700, West Conshohocken, PA 19428-2959, United States. Individual reprints (single or multiple copies) of this standard may be obtained by contacting ASTM at the above address or at 610-832-9585 (phone), 610-832-9555 (fax), or service@astm.org (e-mail); or through the ASTM website (www.astm.org). Permission rights to photocopy the standard may also be secured from the ASTM website (www.astm.org/COPYRIGHT/).