



Standard Methods of Static Load Test for Combined Tensile and Transverse Load Resistance of Paneled Wall Systems in Building Construction¹

This standard is issued under the fixed designation E2127; the number immediately following the designation indicates the year of original adoption or, in the case of revision, the year of last revision. A number in parentheses indicates the year of last reapproval. A superscript epsilon (ϵ) indicates an editorial change since the last revision or reapproval.

^{e1} NOTE—Units statement was inserted in 1.4 editorially in March 2015.

1. Scope

1.1 These test methods cover the procedures for determining the resistance of paneled wall systems subjected to combined lateral loads and axial loads.

1.2 These test methods involve the simultaneous application of transverse (lateral wind) and tensile (wind uplift) loads to paneled wall system assemblies anchored at both ends with hold-down connectors.

1.3 These test methods are suitable for determining the structural adequacy of the design, system, and wall fabrication technique, and are not intended to evaluate the strength capacity of the hold-down connectors.

1.4 The values stated in inch-pound units are to be regarded as standard. The values given in parentheses are mathematical conversions to SI units that are provided for information only and are not considered standard.

1.5 *This standard does not purport to address all of the safety concerns, if any, associated with its use. It is the responsibility of the user of this standard to establish appropriate safety and health practices and determine the applicability of regulatory limitations prior to use.*

2. Referenced Documents

2.1 *ASTM Standards:*²

[E575 Practice for Reporting Data from Structural Tests of Building Constructions, Elements, Connections, and Assemblies](#)

¹ These test methods are under the jurisdiction of ASTM Committee E06 on Performance of Buildings and are the direct responsibility of Subcommittee E06.11 on Horizontal and Vertical Structures/Structural Performance of Completed Structures.

Current edition approved March 1, 2015. Published March 2015. Originally approved in 2001. Last previous edition approved in 2007 as E2127 – 01a (2007). DOI: 10.1520/E2127-01AR15E01.

² For referenced ASTM standards, visit the ASTM website, www.astm.org, or contact ASTM Customer Service at service@astm.org. For *Annual Book of ASTM Standards* volume information, refer to the standard's Document Summary page on the ASTM website.

[E631 Terminology of Building Constructions](#)

3. Terminology

3.1 *Definitions*—For definitions of general terms used in this test method, refer to Terminology [E631](#).

4. Summary of Test Method

4.1 The tensile and bending capacity of the paneled wall system is determined by applying a simultaneous tensile and transverse load to a wall specimen. This is accomplished by anchoring one end of the specimen and applying a tensile load to the opposing end while applying a transverse load; see [Figs. 1 and 2](#). The forces required to deflect the specimen and the corresponding displacements at each load interval are measured.

5. Significance and Use

5.1 The procedures described will test the behavior of segments of paneled wall system construction under conditions representative of those encountered in service. Performance criteria based on data from those procedures can verify structural adequacy and service life.

6. Test Apparatus

6.1 *Test Assembly:*

6.1.1 *General*—Tests shall be made on three like specimens for each orientation. All system elements shall be fastened in a manner to conform with the wall specifications. The wall system shall be representative of actual building construction.

6.1.2 *Connections*—The performance of the wall is influenced by the type and spacing of the anchoring to the upper and lower ends of the wall.

6.1.3 *Paneled Wall System Requirements*—The paneled wall system specimen shall be comprised of members and connectors representative of those used in building construction, except that the specimen is permitted to consist of a core on which paneled wall system surface units are placed.

6.1.4 *Test Setup*—The paneled wall system specimen shall be tested vertically or horizontally so that surface units may be

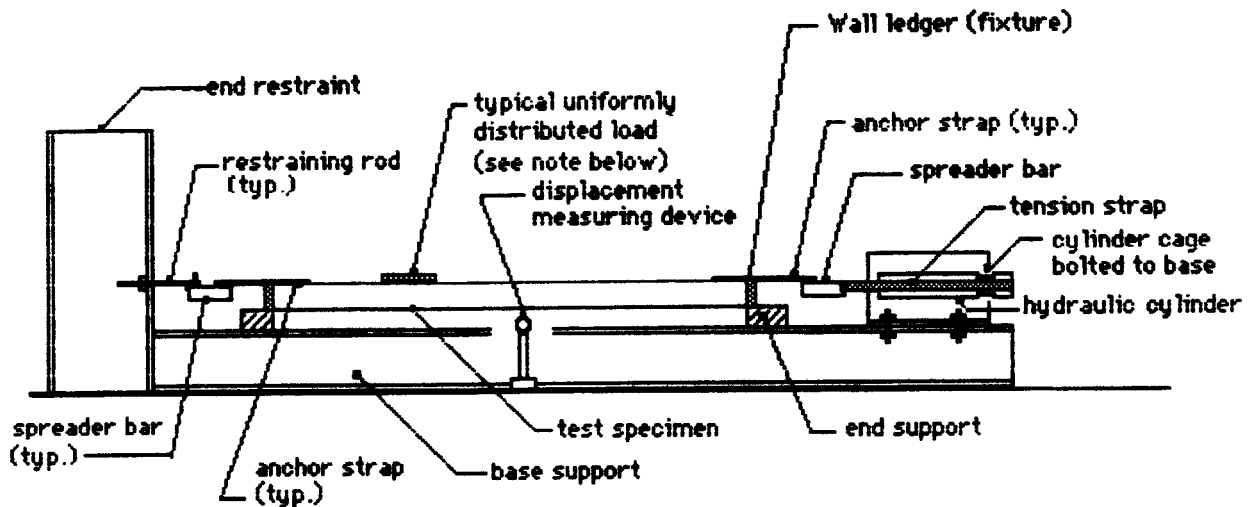

SIDE VIEW

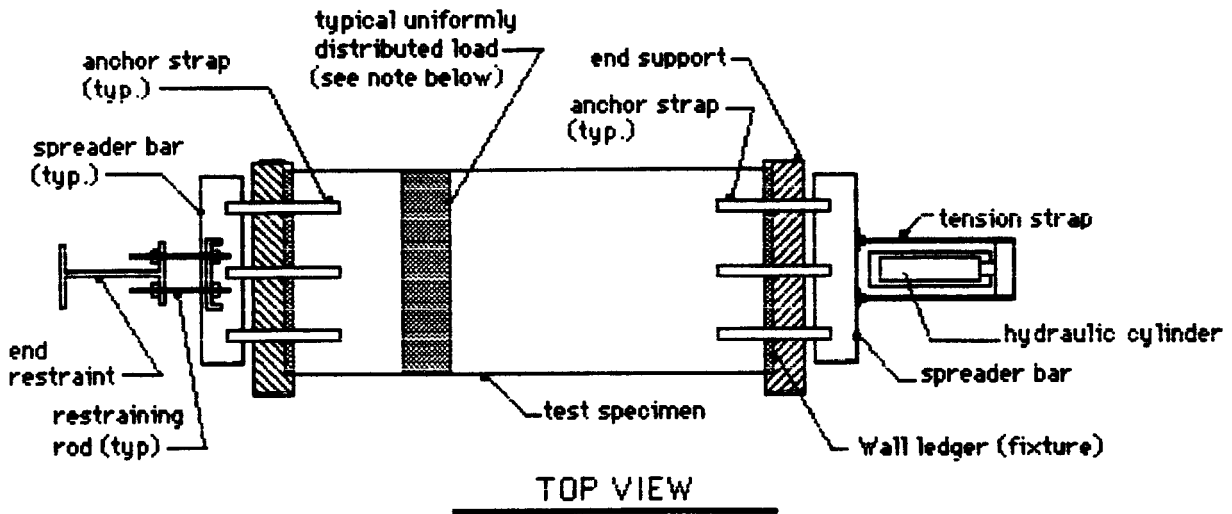

TOP VIEW

TEST SPECIMEN AND FIXTURE

STRAPS UP

Note: Partial uniformly distributed load shown for simplification purposes.

FIG. 1 Test Specimen and Fixture, Straps Up

observed during the test. The test fixture shall allow for simultaneous transverse and tensile load application. The top and bottom of the specimen shall be attached to rigid supports.

6.1.5 *Paneled Wall System Size*—The paneled wall system specimen height shall not be less than the actual height of the wall, and the width shall be minimum 48 in. (120 cm) wide, or the width of an individual wall panel (if the individual panel width is greater than 48 in. wide).

7. Procedure

7.1 *Number of Tests*—Conduct a minimum of three tests for each of the two orientations. Conduct the first set of tests with the specimen orientation applicable to the positive pressure load application; see Fig. 1; conduct the second set of tests with the specimen orientation applicable to the negative pressure load application; see Fig. 2.

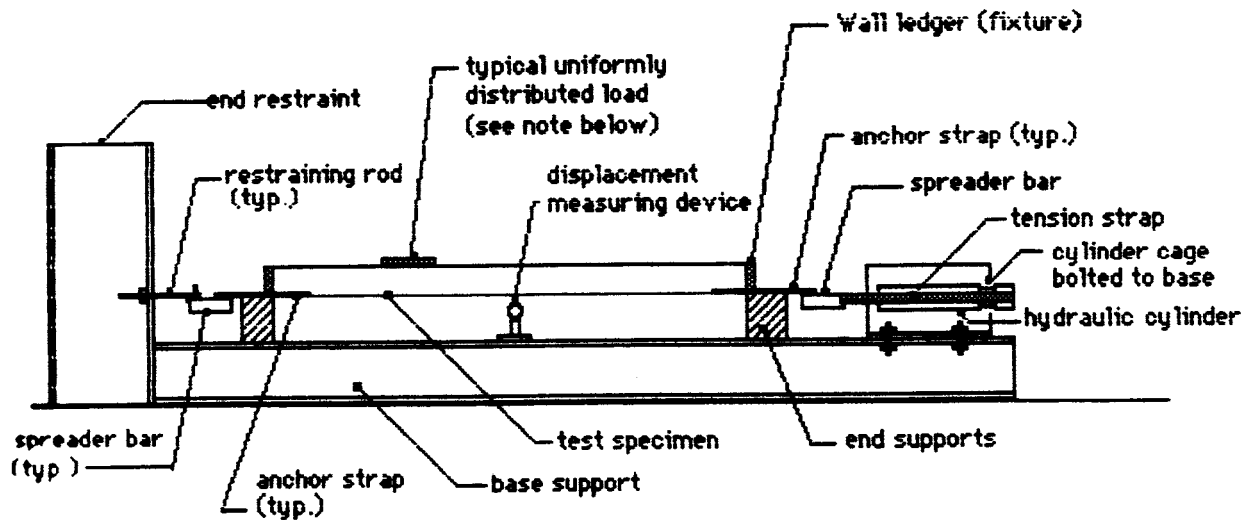

SIDE VIEW

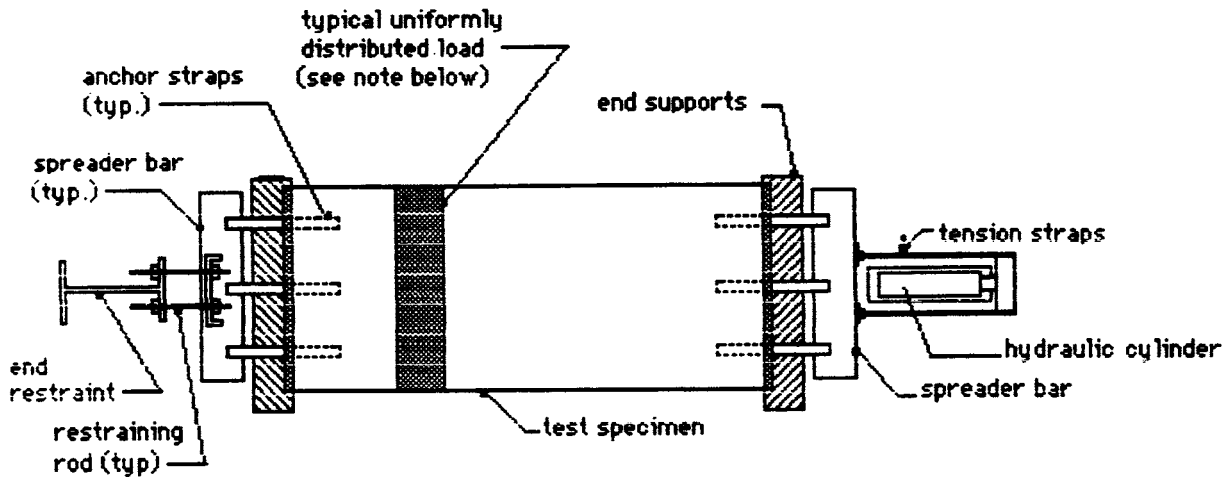

TOP VIEW

TEST SPECIMEN AND FIXTURE

STRAPS DOWN

Note: Partial uniformly distributed load shown for simplification purposes.

FIG. 2 Test Specimen and Fixture, Straps Down

7.1.1 Loading—The loading procedure should be as follows:

- 7.1.1.1 Record midspan deflection values at “zero” load.
- 7.1.1.2 Apply $\frac{1}{4}$ of the design tensile load along the longitudinal axis of the paneled wall system specimen.
- 7.1.1.3 Allow a minimum of 5 min before recording the midspan displacement.
- 7.1.1.4 Record the midspan displacement.

7.1.1.5 Apply a uniformly distributed load equivalent to $\frac{1}{4}$ the design lateral load over the entire surface of the specimen.

- 7.1.1.6 Allow a minimum of 5 min before recording the midspan displacement.
- 7.1.1.7 Record the midspan displacement.
- 7.1.1.8 Repeat steps 7.1.1.2 – 7.1.1.7 increasing the tensile and lateral loads by $\frac{1}{4}$ design load increments until the 1.25 design tensile and lateral load values are achieved.

7.1.1.9 Record the midspan displacement.

7.1.1.10 Remove the displacement measuring devices.

7.1.1.11 Apply 2.5 times the design tensile load along the longitudinal axis of the specimen.

7.1.1.12 Apply a uniformly distributed load equivalent to 2.5 times the design lateral load over the entire surface of the specimen.

7.1.1.13 Choose the rate of loading such that the anticipated design load level will be reached in not less than 20 min. The duration of load application at each increment shall permit load and deformation readings to be recorded. Apply the loads by hydraulic jack(s) or by other suitable types of loading apparatus that have been previously calibrated. Gages for measuring loads and displacement shall be accurate to within 2 % at design load. Record the duration of load at each level throughout the test.

8. Calculation

8.1 Base evaluation on the mean values resulting from tests of like specimens.

8.2 The applied axial load is to be equivalent to the uplift load acting on the section of the paneled wall system at the hold-down location.

8.3 The lateral load is equivalent to positive or negative wind pressure acting on the section of the paneled wall system.

8.4 Calculate the displacement at each load application interval as the difference between the readings when the load is applied and the initial reading at the start of the test.

9. Report

9.1 The report shall follow the format and contain information in accordance with Practice **E575**.

10. Precision and Bias

10.1 Because of the nature of these tests and the variety of techniques that can be employed in conducting them, no statement can be made about their precision and bias.

11. Keywords

11.1 axial load; combined loading; displacement; lateral load; paneled wall system; wall panel testing

APPENDIX

(Nonmandatory Information)

X1. TESTING FOR DISPLACEMENT

X1.1 Due to the variety of materials that could be present in a paneled wall system, testing for displacement under various loads becomes a simpler method when compared to analytical computations.

X1.2 The term *design load* refers to the load specified by the sponsor of the test.

ASTM International takes no position respecting the validity of any patent rights asserted in connection with any item mentioned in this standard. Users of this standard are expressly advised that determination of the validity of any such patent rights, and the risk of infringement of such rights, are entirely their own responsibility.

This standard is subject to revision at any time by the responsible technical committee and must be reviewed every five years and if not revised, either reapproved or withdrawn. Your comments are invited either for revision of this standard or for additional standards and should be addressed to ASTM International Headquarters. Your comments will receive careful consideration at a meeting of the responsible technical committee, which you may attend. If you feel that your comments have not received a fair hearing you should make your views known to the ASTM Committee on Standards, at the address shown below.

This standard is copyrighted by ASTM International, 100 Barr Harbor Drive, PO Box C700, West Conshohocken, PA 19428-2959, United States. Individual reprints (single or multiple copies) of this standard may be obtained by contacting ASTM at the above address or at 610-832-9585 (phone), 610-832-9555 (fax), or service@astm.org (e-mail); or through the ASTM website (www.astm.org). Permission rights to photocopy the standard may also be secured from the Copyright Clearance Center, 222 Rosewood Drive, Danvers, MA 01923, Tel: (978) 646-2600; <http://www.copyright.com/>