



# Standard Test Method for Fire Tests of Door Assemblies, Including Positive Pressure Testing of Side-Hinged and Pivoted Swinging Door Assemblies<sup>1</sup>

This standard is issued under the fixed designation E 2074; the number immediately following the designation indicates the year of original adoption or, in the case of revision, the year of last revision. A number in parentheses indicates the year of last reapproval. A superscript epsilon ( $\epsilon$ ) indicates an editorial change since the last revision or reapproval.

---

<sup>ε1</sup> NOTE—The fire-test-response caveat was updated in October 2004.

---

## INTRODUCTION

This fire-test-response standard replaces E 152, Standard Methods of Fire Tests of Door Assemblies, which was formerly under the jurisdiction of Committee E-5 on Fire Standards. The E 152 standard was withdrawn on January 1, 1995 in accordance with Section 10.5.3.1 of the *Regulations Governing ASTM Technical Committee*, which requires that standards shall be updated by the end of the eighth year since last approval date.

### 1. Scope

1.1 This fire-test-response standard is applicable to door assemblies for use in walls to retard the passage of fire (see X1.1-X1.3.).

1.2 This fire-test-response standard determines the ability of door assemblies to function as a fire-resistive barrier during a standard fire endurance test. Such a test method shall not be construed as determining the suitability of door assemblies for continued use after their exposure to fire.

1.3 This fire-test-response standard is intended to evaluate the ability of a door assembly to remain in an opening during a predetermined test exposure, which when required by 12.10 is then followed by the application of a hose stream (see X1.4 and X1.5).

1.4 The hose stream test used in this test method is not designed to be representative of an actual hose stream used by a fire department during fire suppression efforts.

1.5 The fire exposure is not representative of all fire conditions, which vary with changes in the amount, nature, and distribution of the fire loading, ventilation, compartment size and configuration, and heat characteristics of the compartment. It does, however, provide a relative measure of fire endurance of door assemblies under specified fire exposure conditions.

1.6 Any variation from the tested construction or test conditions will possibly change the performance characteristics of door assembly.

1.7 This fire-test-response standard *does not* provide the following:

1.7.1 The fire endurance of door assemblies constructed of materials other than those tested.

1.7.2 A temperature limit on the unexposed surface of the door assembly, although the temperatures are measured and recorded.

1.7.3 A limit on the number of openings allowed in glazed areas or of the number and size of lateral openings between the door and frame.

1.7.4 A measurement of smoke or products of combustion that pass through the door assembly.

1.7.5 A measurement of smoke, toxic gases, or other products of combustion generated by the door assembly.

NOTE 1—The information in 1.7.4 and 1.7.5 may be important in determining the fire hazard or fire risk of door assemblies under actual fire conditions. This information may be determined by other suitable fire test methods. For example, flame spread and smoke development may be determined by Test Method E 84.

1.8 *This standard does not purport to address all of the safety concerns, if any, associated with its use. It is the responsibility of the user of this standard to establish appropriate safety and health practices and determine the applicability of regulatory limitations prior to use.*

1.9 *This standard is used to measure and describe the response of materials, products, or assemblies to heat and flame under controlled conditions, but does not by itself incorporate all factors required for fire hazard or fire risk assessment of the materials, products, or assemblies under actual fire conditions*

---

<sup>1</sup> This test method is under the jurisdiction of ASTM Committee E-5 on Fire Standards and is the direct responsibility of Subcommittee E05.11 on Fire Endurance.

Current edition approved March 10, 2000. Published May 2000.

1.10 This test method references notes and footnotes which provide explanatory material. These notes and footnotes (excluding those in tables and figures) shall not be considered as requirements of this test method.

1.11 The values stated in either inch-pound units or SI units are to be regarded separately as standard. The values stated in each system may not be exact equivalents; therefore, each system shall be used independently of the other. Combining values from the two systems may result in nonconformance with the standard.

**2. Referenced Documents**

2.1 *ASTM Standards:*<sup>2</sup>

E 84 Test Method for Surface Burning Characteristics of Building Materials

E 119 Tests Methods for Fire Tests of Building Construction and Materials

E 152 Methods of Fire Tests of Door Assemblies<sup>3</sup>

E 176 Terminology of Fire Standards

E 631 Terminology of Building Constructions

2.2 *Other Documents:*

UL 385 Standard for Play Pipes for Water Supply Testing in Fire-Protection Service, 1993<sup>4</sup>

**3. Terminology**

3.1 For the purpose of this test method, the definitions given in Terminologies E 176 and E 631, together with the following, shall apply:

3.1.1 *integrity, n*—the ability of a test assembly, when exposed to fire from one side, to prevent the passage of flame and hot gases through it or the occurrence of flames on its unexposed side.

3.1.2 *through-opening, n*—an uninterrupted hole in the test assembly that is seen from the unexposed side when viewing the suspected hole from a position perpendicular to the plane of the test assembly.

**4. Summary of Test Method**

4.1 This fire-test-response standard describes the following test sequence and procedure.

4.1.1 A door assembly is exposed to a standard fire exposure, controlled to achieve specified temperatures and pressures throughout a specified time period.

4.1.2 The integrity of the door assembly is evaluated using a cotton wool pad test when the average unexposed surface temperature of a door assembly is less than 650°F (361°C) above ambient and openings are created by the fire exposure.

4.1.3 After the fire endurance test the door assembly is subjected to a hose stream test when required by 12.10.

**5. Significance and Use**

5.1 In this fire-test-response standard, the test specimens are subjected to one or more specific sets of laboratory test conditions. When different test conditions are substituted or the end-use conditions are changed, it is not always possible by, or from, this test method to predict changes to the characteristics measured. Therefore, the results are valid only for the exposure conditions described in this test method.

5.2 This fire-test-response standard measures and records the temperatures on the unexposed side of a door assembly. This data is intended to assist and enable regulatory bodies to determine the suitability of door assemblies for use in locations where fire resistance of a specified duration is required.

5.3 The data is not intended to be used to describe or appraise the fire hazard or fire risk of materials, products, or assemblies under actual fire conditions.

5.4 This fire-test-response standard requires that observations be made and recorded relevant to the passage of flame.

5.5 This fire-test-response standard uses a cotton wool pad test to assess the integrity of the door assembly relevant to the passage of hot gases.

5.6 This fire-test-response standard uses a hose stream test to assess the durability of the door assembly relevant to the passage of a stream of water.

**6. Apparatus**

6.1 *Furnace and Test Frame:*

6.1.1 The furnace construction shall be suitable to meet the requirements of the fire test protocol. An example of the furnace and test frame is illustrated in Fig. 1 (see X1.6).

6.1.2 The height and width of the furnace opening shall be greater than the test assembly's corresponding dimension.

6.1.3 The furnace shall be heated with burners that are fired using either natural gas or liquefied petroleum gases. The burners shall have a controllable heat output (see X1.8) and be able to expose the test assembly to the uniform heating of the standard time-temperature curve.

6.2 *Copper Disk Thermocouples:*

6.2.1 The copper disk thermocouples shall be covered by pads as specified in 6.2.4, reference Fig. 2, and shall have a

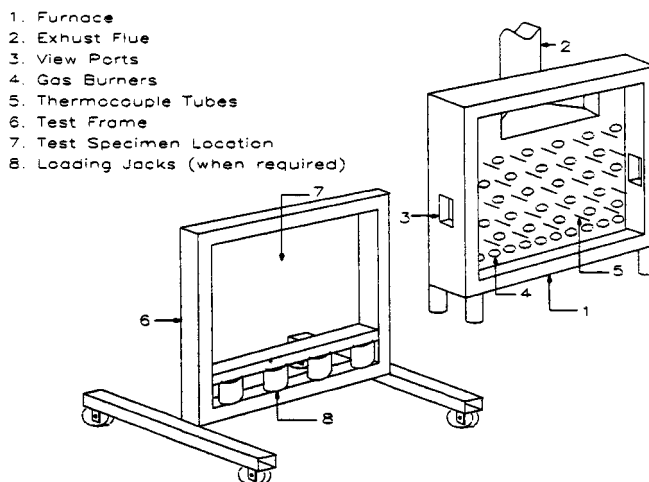
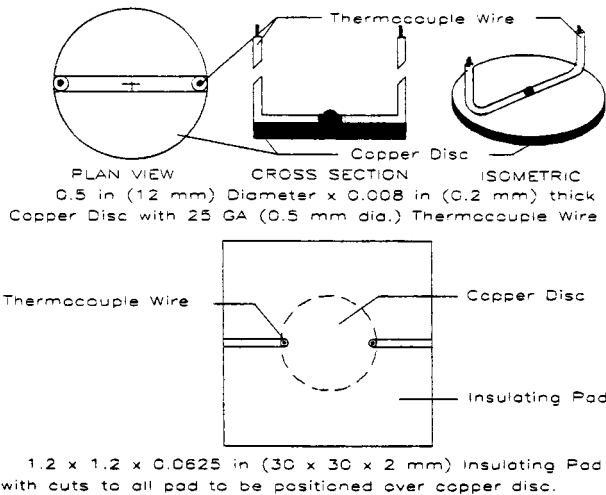

FIG. 1 Furnace and Test Frame

<sup>2</sup> For referenced ASTM standards, visit the ASTM website, www.astm.org, or contact ASTM Customer Service at service@astm.org. For *Annual Book of ASTM Standards* volume information, refer to the standard's Document Summary page on the ASTM website.

<sup>3</sup> Withdrawn.

<sup>4</sup> Available from Underwriters Laboratories, 333 Pfingsten Road, Northbrook, IL 60062.



**FIG. 2 Example of a Typical Thermocouple Disk and Insulating Pad**

wire diameter of not more than 0.03 in. (0.7 mm), and be brazed to the center of the face of a copper disk having the following nominal measurements: ½ in. (12 mm) in diameter and 0.01 in. (0.2 mm) thick.

**6.2.2 Thermocouple Insulating Pads:**

6.2.2.1 Refractory fiber pads shall have the following properties:

6.2.2.1.1 *Length and Width*, 1.20 ± 0.02 in. (30 ± 0.5 mm),

6.2.2.1.2 *Thickness*, 0.08 ± 0.02 in. (2 ± 0.5 mm), and

6.2.2.1.3 *Density*, 56.2 ± 6.2 lb/ft<sup>3</sup> (900 ± 100 kg/m<sup>3</sup>).

6.2.2.2 If necessary, it is permitted to shape the pads by wetting, forming, and then drying them to provide complete contact on sharply contoured surfaces.

6.3 *Pressure-Sensing Probes*—Except for the diameters of the steel tubes, tolerances are ±5 % of the dimensions shown in Fig. 3 or Fig. 4.

6.3.1 The pressure-sensing probes shall be either: a T-shaped sensor as shown in Fig. 3, or a tube sensor as shown in Fig. 4.

**6.4 Differential Pressure Measurement Instruments:**

6.4.1 The differential pressure measurement instrument shall be: a manometer or transducer, and capable of reading in graduated increments of no greater than 0.01 in. H<sub>2</sub>O (2.5 Pa) with a precision of not less than ±0.005 in. H<sub>2</sub>O (±1.25 Pa).

**6.5 Hose Stream Delivery System:**

6.5.1 The hose stream delivery system shall consist of the following:

6.5.1.1 A standard 2½-in. (64-mm) diameter hose attached to a national standard play pipe as described in UL 385.

6.5.1.2 The play pipe shall have an overall length of 30 ± 0.25 in. (762 ± 6 mm) and shall be equipped with a standard 1⅛-in. (28.5-mm) discharge tip of the standard-taper-smooth-bore pattern without shoulder at the orifice.

6.5.1.3 The play pipe shall be fitted with a standard 2½-in. (64-mm) inside dimension by 6-in. (153-mm) long nipple mounted between the hose and the base of the play pipe.

6.5.1.4 A pressure tap for measuring the water pressure at the base of the nozzle shall be normal to the surface of the nipple, shall be centered in its length, and shall not protrude into the water stream.

6.5.1.5 A suitable pressure gage capable of reading a minimum of 0 to 50 psi (0 to 344.8 kPa) and graduated into no greater than 2-psi (13.8-kPa) increments shall be used to measure the water pressure.

**6.6 Furnace Thermocouples:**

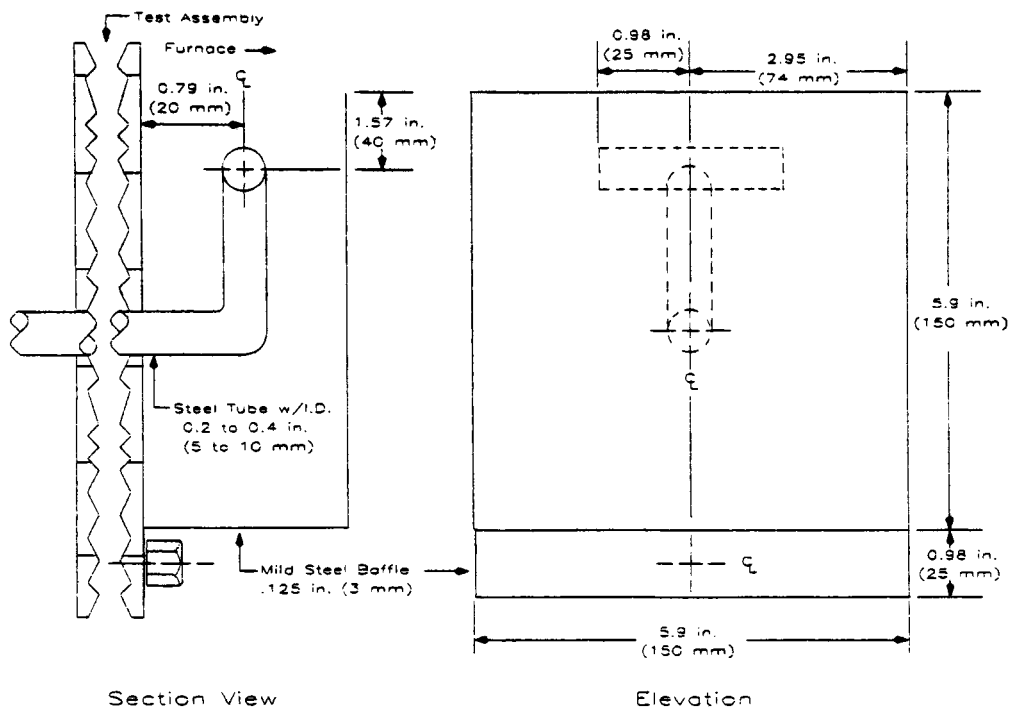

**FIG. 3 T-Shaped Sensor**

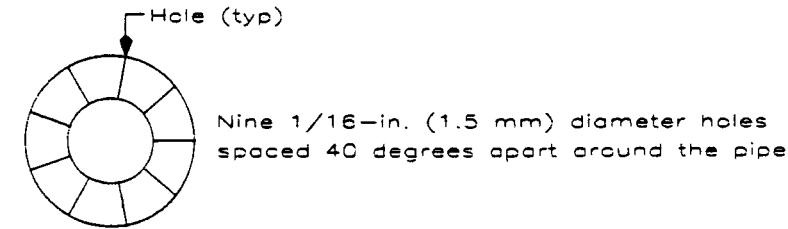
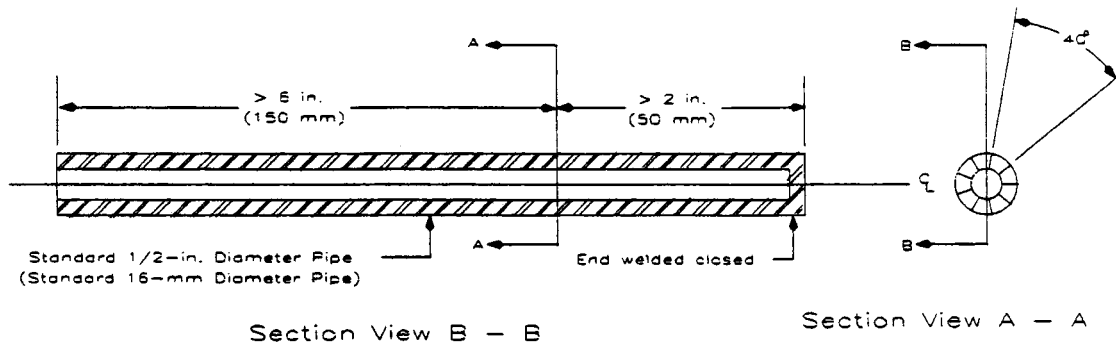

Enlarged Section View A - A

FIG. 4 Tube Sensor

6.6.1 The furnace thermocouples shall:

6.6.1.1 Be protected by sealed porcelain tubes having a nominal 3/4-in. (19-mm) outside diameter and 1/8-in. (3-mm) wall thickness, or, as an alternative, in the case of base metal thermocouples, protected by a standard 1/2-in. (13-mm) diameter wrought steel or wrought iron pipe of standard weight, and

6.6.1.2 Have a time constant in the range from 6.0 to 7.2 min while encased in the tubes described in 6.6.1.1.

NOTE 2—A typical thermocouple assembly meeting these time constant requirements may be fabricated by fusion-welding the twisted ends of No. 18 gage Chromel-Alumel wires, mounting the leads in porcelain insulators, and inserting the assembly so the thermocouple bead is 0.5 in. (25 mm) from the sealed end of the standard weight nominal 1/2-in. iron, steel, or Inconel<sup>5</sup> pipe. The time constant for this and for several other thermocouple assemblies was measured in 1976. The time constant may also be calculated from knowledge of its physical and thermal properties.<sup>6</sup>

6.6.2 Other types of protection tubes or pyrometers are permitted to be used provided that under test conditions they give the same indications as those of 6.6.1 within the limit of accuracy that applies for furnace-temperature measurements.

6.7 Cotton Wool Pads:

6.7.1 The cotton wool pads shall:

6.7.1.1 Measure 4 ± 0.125 in. (100 ± 3 mm) long by 4 ± 0.125 in. (100 ± 3 mm) wide by 0.85 ± 0.0625 in. (20 ± 2 mm) thick,

6.7.1.2 Consist only of new undyed soft cotton fibers, without any admixture of artificial fibers,

6.7.1.3 Have a mass between 3 and 4 g, and

6.7.1.4 Be attached using wire clips to a wire frame. The frame used to hold the cotton wool pad is to be formed of steel wire (typically No. 15 AWG (1.5 mm)) and is to be provided with a handle long enough to reach all points of the test assembly. See Fig. 5.

6.7.1.5 The cotton wool pads are to be conditioned prior to use by drying in an oven at 212 ± 9°F (100 ± 5°C) for at least 30 min. After drying, the cotton wool pads shall be stored in a desiccator until they are used.

7. Time-Temperature Curve

7.1 The fire exposure of door assemblies shall be controlled to conform to the applicable portion of the standard time-temperature curve shown in Fig. 6 (see X1.7). The points on the curve that determine its character are as follows:

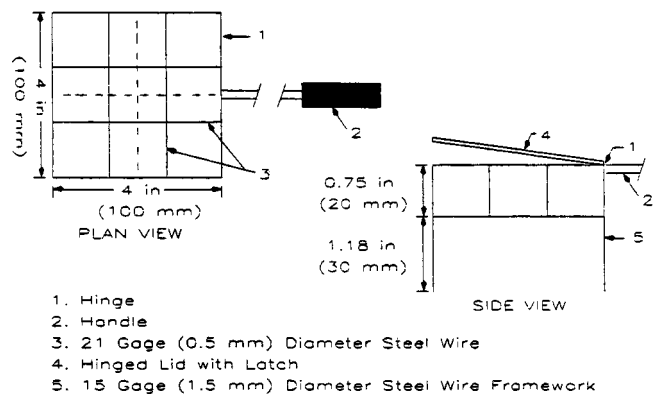

- 1. Hinge
- 2. Handle
- 3. 21 Gage (0.5 mm) Diameter Steel Wire
- 4. Hinged Lid with Latch
- 5. 15 Gage (1.5 mm) Diameter Steel Wire Framework

NOTE 1: Solid lines illustrate the framework.  
NOTE 2: Dashed lines illustrate the hinged lid.

FIG. 5 Example of a Typical Cotton Wool Pad Holder

<sup>5</sup> Inconel is a registered trade name of INCO Alloys, Inc., 3800 Riverside Dr., Huntington, WV 25720.

<sup>6</sup> Supporting data is available from ASTM Headquarters. Request RR:E05-1001.

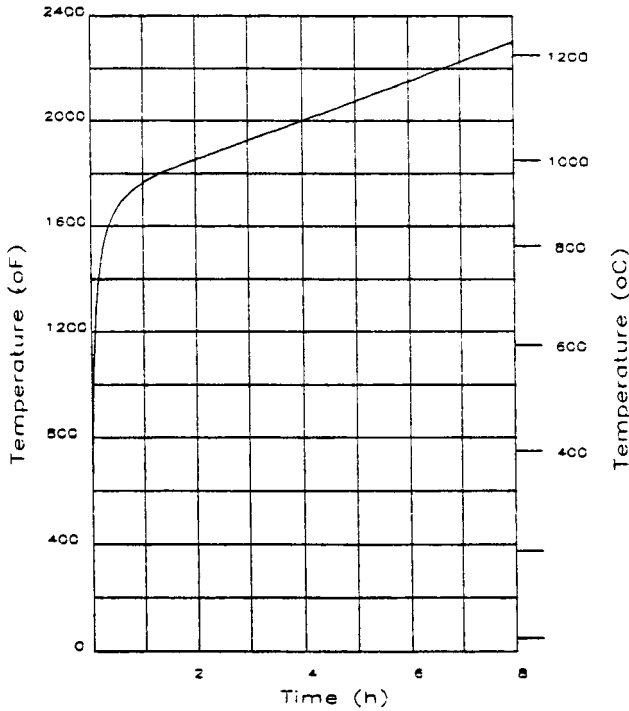

FIG. 6 Standard Time-Temperature Curve

1000°F (538°C)	at 5 min
1300°F (704°C)	at 10 min
1550°F (843°C)	at 30 min
1700°F (926°C)	at 1 h
1850°F (1010°C)	at 2 h
2000°F (1093°C)	at 4 h
2300°F (1260°C)	at 8 h or over

7.1.1 For a more detailed definition of the time-temperature curve, refer to Table 1.

7.1.2 The temperature inside the furnace recorded at the start of the test shall be considered ambient.

### 8. Furnace Temperatures

8.1 The temperatures of the test exposure shall be deemed to be the average temperature obtained from the readings of not less than nine thermocouples symmetrically disposed and distributed to show the temperature near all parts of the test assembly.

8.2 Originally locate the junction of the thermocouples  $6 \pm 0.25$  in. ( $152 \pm 6$  mm) from the exposed face of the test assembly or from the construction in which the assembly is installed.

8.2.1 Verify the distance established in 8.2 at intervals not exceeding 10 min during the first 30 min of the test and thereafter at intervals not exceeding 30 min.

8.2.2 Whenever the distance is not as specified in 8.2, reset the distance to comply with 8.2.

8.3 The furnace temperatures shall be measured and recorded at intervals not exceeding 1 min.

8.4 The accuracy of the furnace control shall be such that the area under the time-temperature curve, obtained by averaging the results from the thermocouple readings, is within 10 % of the corresponding area under the standard time-temperature curve for fire tests of 1-h or less duration, within

TABLE 1 Standard Time-Temperature Curve for Control of Fire Tests

Time, h/min	Temperature, °F	Area Above 68°F base		Temperature, °C	Area Above 20°C base	
		°F·min	°F·h		°C·min	°C·h
0:00	68	0	0	20	0	0
0:05	1 000	2 330	39	538	1 290	22
0:10	1 300	7 740	129	704	4 300	72
0:15	1 399	14 150	236	760	7 860	131
0:20	1 462	20 970	350	795	11 650	14
0:25	1 510	28 050	468	821	15 590	260
0:30	1 550	35 360	589	843	19 650	328
0:35	1 584	42 860	714	862	23 810	397
0:40	1 613	50 510	842	878	28 060	468
0:45	1 638	58 300	971	892	32 390	540
0:50	1 661	66 200	1 103	905	36 780	613
0:55	1 681	74 220	1 237	916	41 230	687
1:00	1 700	82 330	1 372	927	45 740	762
1:05	1 718	90 540	1 509	937	50 300	838
1:10	1 735	98 830	1 647	946	54 910	915
1:15	1 650	107 200	1 787	955	59 560	993
1:20	1 765	115 650	1 928	963	64 250	1 071
1:25	1 779	124 180	2 070	971	68 990	1 150
1:30	1 792	132 760	2 213	978	73 760	1 229
1:35	1 804	141 420	2 357	985	78 560	1 309
1:40	1 815	150 120	2 502	991	83 400	1 390
1:45	1 826	158 890	2 648	996	88 280	1 471
1:50	1 835	167 700	2 795	1 001	93 170	1 553
1:55	1 843	176 550	2 942	1 006	98 080	1 635
2:00	1 850	185 440	3 091	1 010	103 020	1 717
2:10	1 862	203 330	3 389	1 017	112 960	1 882
2:20	1 875	221 330	3 689	1 024	122 960	2 049
2:30	1 888	239 470	3 991	1 031	133 040	2 217
2:40	1 900	257 720	4 295	1 038	143 180	2 386
2:50	1 912	276 110	4 602	1 045	153 390	2 556
3:00	1 925	294 610	4 910	1 052	163 670	2 728
3:10	1 938	313 250	5 221	1 059	174 030	2 900
3:20	1 950	332 000	5 533	1 066	184 450	3 074
3:30	1 962	350 890	5 848	1 072	194 940	3 249
3:40	1 975	369 890	6 165	1 079	205 500	3 425
3:50	1 988	389 030	6 484	1 086	216 130	3 602
4:00	2 000	408 280	6 805	1 093	226 820	3 780
4:10	2 012	427 670	7 128	1 100	237 590	3 960
4:20	2 025	447 180	7 453	1 107	248 430	4 140
4:30	2 038	466 810	7 780	1 114	259 340	4 322
4:40	2 050	486 560	8 110	1 121	270 310	4 505
4:50	2 062	506 450	8 441	1 128	281 360	4 689
5:00	2 075	526 450	8 774	1 135	292 470	4 874
5:10	2 088	546 580	9 110	1 142	303 660	5 061
5:20	2 100	566 840	9 447	1 149	314 910	5 248
5:30	2 112	587 220	9 787	1 156	326 240	5 437
5:40	2 125	607 730	10 129	1 163	337 630	5 627
5:50	2 138	628 360	10 473	1 170	349 090	5 818
6:00	2 150	649 120	10 819	1 177	360 620	6 010
6:10	2 162	670 000	11 167	1 184	372 230	6 204
6:20	2 175	691 010	11 517	1 191	383 900	6 398
6:30	2 188	712 140	11 869	1 198	395 640	6 594
6:40	2 200	733 400	12 223	1 204	407 450	6 791
6:50	2 212	754 780	12 580	1 211	419 330	6 989
7:00	2 225	776 290	12 938	1 218	431 270	7 188
7:10	2 238	797 920	13 299	1 225	443 290	7 388
7:20	2 250	819 680	13 661	1 232	455 380	7 590
7:30	2 262	841 560	14 026	1 239	467 540	7 792
7:40	2 275	863 570	14 393	1 246	479 760	7 996
7:50	2 288	885 700	14 762	1 253	492 060	8 201
8:00	2 300	907 960	15 133	1 260	504 420	8 407

7.5 % for those over 1 h and not more than 2 h, and within 5 % for tests exceeding 2 h in duration.

### 9. Unexposed Surface Temperatures and Cotton Wool Pad Application

9.1 Unexposed surface temperatures (see X1.9) shall be measured, recorded, and determined in the following manner:



9.1.1 Unexposed surface temperatures shall be taken at not less than three points with at least one thermocouple in each 16-ft<sup>2</sup> (1.5-m<sup>2</sup>) area of the door assembly. Thermocouples shall not be located over reinforcements extending through the door assembly, over vision panels, or nearer than 12 in. (305 mm) from the edge of the door assembly.

9.1.2 Unexposed surface temperatures shall be measured with copper disk thermocouples placed under dry felted pads, both meeting the requirements of 6.2. The pads shall be held firmly against the surface of the door assembly and fit closely about the thermocouples.

9.1.3 Unexposed surface temperatures shall be measured and recorded at intervals not exceeding 1 min.

9.1.4 When requested by the test sponsor, remove the copper disk thermocouples and pads after the first 30 min of the test and cease recording unexposed surface temperatures.

9.2 *Cotton Wool Pad Application*—When the average unexposed surface temperature of a door assembly is less than 650°F (343°C) during the first 30 min of the test, evaluate the integrity of the test assembly during the fire endurance test using a cotton wool pad in a wire frame provided with a handle. The passage of flames and hot gases, through cracks, holes, or other openings in the test assembly that have developed due to the fire test exposure, shall be determined by applying a cotton wool pad to such openings at intervals not exceeding 2 min during the test. The cotton wool pad shall comply with 6.7 and the following:

9.2.1 Be held in place for a minimum of 20 s, but not more than 30 s,

9.2.2 Be located  $1 \pm 0.25$  in. ( $25 \pm 5$  mm) away from and centered above such openings,

9.2.3 Shall not come in contact with the surface of the test assembly,

9.2.4 Shall not be reused if it has charred during a previous application or if it has absorbed any moisture, and

9.2.5 When no ignition (defined as glowing or flaming) of the cotton wool pad occurs during the minimum 20-s application, make screening tests that involve: (1) short-duration applications of the cotton wool pad to areas of potential failure or (2) the movement of a single pad over and around such areas, or both. Charring of the pad only provides an indication of imminent failure. Employ a previously unused cotton wool pad for an integrity failure to be confirmed.

## 10. Furnace Pressure

10.1 The pressure in the furnace shall be measured using pressure-sensing probes which comply with 6.3.

10.2 The pressure in the furnace shall be measured using at least two probes located within the furnace and separated by a vertical distance of at least 6 ft (1.8 m) (see X1.12). It is permitted to reduce the vertical separation to 3 ft (0.9 m) when one of the pressure probes is located 40 in. above the sill.

10.3 Locate the probes as near to the vertical centerline of the furnace opening as practical.

10.4 Use a differential pressure measurement instrument which complies with 6.4 to measure the pressure. Locate the differential pressure measurement instrument to minimize the “stack” effects caused by vertical runs of pressure tubing between the furnace probe and instrument locations.

## 11. Test Assemblies

### 11.1 Construction and Size:

11.1.1 Make the door assembly full size. Make the construction and size of the door assembly, consisting of single doors, doors in pairs, special-purpose doors (such as Dutch doors, double-egress doors, and so forth), or multi-section doors, representative of that for which a fire endurance rating is desired (see X1.10).

11.1.2 Provide a floor structure as part of the opening to be protected, except where such floor interferes with the operation of the door. Construct the floor segment of noncombustible material and project it into the furnace approximately twice the thickness of the test door assembly, or to the limit of the frame, whichever is greater.

NOTE 3—See Terminology E 176 for the definition of “noncombustible.”

11.1.3 Fire test asymmetrical door assemblies from both sides unless the door assembly is designed and designated for fire exposure from only one side or it is determined and documented in the report by the laboratory that the side being tested represents the more onerous condition.

NOTE 4—It is permitted to install more than one door assembly into the test wall assembly to simultaneously test more than one door assembly or both sides of one door assembly.

### 11.2 Installation:

11.2.1 Place the door assembly in a wall. Make the wall in which the door assembly is to be tested adequate to retain the door assembly throughout the fire and hose stream test and constructed of masonry or other materials representative of wall construction.

11.2.2 When used, ensure the door frame anchors are suitable for wall construction.

11.2.3 Install all doors such that they fit within their frame, against the wall surfaces, or in guides, but do not allow such installation to prevent free and easy operation of the test door (see X1.11).

11.2.3.1 Install sliding and rolling doors, except horizontal slide-type elevator shaft doors, on the exposed side of the opening in the wall closing the furnace chamber.

11.2.3.2 Install horizontal slide-type elevator shaft doors on the unexposed side of the opening in the wall closing the furnace chamber.

11.2.3.3 Install access-type doors and chute-type doors and frame assemblies so as to have one assembly open into the furnace chamber and another assembly open away from the furnace chamber.

11.2.3.4 Install dumbwaiter and service-counter doors and frame assemblies on the exposed side of the opening in the wall.

11.2.4 After the door frames are installed, verify that the doors open either away from or into the furnace chamber, as required by the laboratory, to obtain representative information on the performance of the construction under test.

11.2.5 Evaluate surface-installed fire-exit hardware for use on the fire doors under conditions in which it is installed in one

door assembly that swings into the furnace chamber and in another door assembly that swings away from the furnace chamber.

11.3 Tolerances and Clearances:

11.3.1 Swinging Doors:

11.3.1.1 Use the following tolerances: -0.0625 in. (1.6 mm) +0.0 in. (0.0 mm).

11.3.1.2 Use the following clearances: 0.125 in. (3.2 mm) along the top, 0.125 in. along the hinge and latch jambs, 0.125 in. along the meeting edge of doors when in pairs, 0.375 in. (11.5 mm) at the bottom edge of a single swinging door, and 0.25 in. (6.3 mm) at the bottom of a pair of doors.

11.3.2 Horizontal Sliding Doors Not Mounted Within Guides:

11.3.2.1 Use the following tolerances: -0.125 in. (3.2 mm) +0.0 in. (0.0 mm).

11.3.2.2 Use the following clearances: 0.5 in. (11.7 mm) between the door and wall surfaces, 0.375 in. (11.5 mm) between the door and floor structure, and 0.25 in. (6.3 mm) between the meeting edges of center-parting doors. Provide a maximum lap of 4 in. (102 mm) of the door over the wall opening at sides and top.

11.3.3 Vertical Sliding Doors Moving Within Guides:

11.3.3.1 Use the following tolerances: -0.125 in. (3.2 mm) +0.0 in. (0.0 mm).

11.3.3.2 Use the following clearances: 0.5 in. (11.7 mm) between the door and wall surfaces along the top or the bottom door edges, or both, with guides mounted directly to the wall surfaces and 0.1875 in. (4.8 mm) between the meeting edges of bi-parting doors or 0.1875 in. (4.8 mm) between the door and floor structure or the sill.

11.3.4 Horizontal Slide-Type Elevator Doors:

11.3.4.1 Use the following tolerances: -0.125 in. (3.2 mm) +0.0 in. (0.0 mm).

11.3.4.2 Use the following clearances: 0.375 in. (10.5 mm) between the door and wall surfaces, 0.375 in. (10.5 mm) between the multi-section door panels, and 0.375 in. from the bottom of a panel to the sill. Overlap multi-section door panels 0.75 in. (19.0 mm). Lap door panels over the wall opening 0.75 in. at the sides and top.

12. Procedure

12.1 Position and secure the test assembly against the furnace opening.

12.2 Simultaneously start the fire endurance test, measuring devices, and data acquisition equipment. Follow the time-temperature curve described in Section 7.

12.3 Measure the pressure at each probe location using a differential pressure measurement instrument.

12.4 Calculate the location of the neutral plane (zero differential pressure) using the vertical separation distance and pressure differences between the probes or determine the location of the neutral plane by direct measurement at one of the probes.

12.5 Within the first 5 min of the fire test, establish the neutral pressure plane in the furnace. For side-hinged and pivoted swinging doors, the neutral pressure plane shall be 40 in. (1016 mm) or less above the sill. For swinging elevator

doors and all other types of doors, the neutral pressure plane shall be at or above the top of the door assembly.

12.6 Read and record the differential pressures at intervals not exceeding 1 min throughout the fire test.

12.7 After the pressure profile in 12.5 is established (using the measurements at the locations specified 10.2), control the furnace pressure for the remainder of the fire test so that the established pressure (at the locations specified 10.2) will not be decreased for (1) the last 25 % of the fire exposure period and (2) an aggregate time period of the following:

12.7.1 Ten percent of the fire exposure for fire tests of 1 h or less,

12.7.2 Seven and one-half percent of the fire exposure for fire tests longer than 1 h but not longer than 2 h, and

12.7.3 Five percent of the fire exposure for fire tests exceeding 2 h in duration.

12.8 When cracks, holes, or other openings in the test assembly have developed due to the fire test exposure, apply the cotton wool pad to evaluate the integrity of the test assembly. See 9.2.

12.9 Continue the fire endurance test until the exposure period of the desired classification or rating is reached unless the minimum requirements set forth in Section 13 are exceeded in a shorter period.

12.10 Within 3 min following the fire endurance test, subject the fire side of the test assembly to a hose stream delivered through a system as described in 6.5 (see X1.13). For asymmetrical swinging doors in a door assembly, apply the hose stream to the door swinging into the furnace only. At the option of the test sponsor, the hose stream test shall not be required to be performed on 20-min rated assemblies.

12.11 Locate the tip of the nozzle  $20 \pm 0.3$  ft ( $6 \pm 0.1$  m) from, and on a line normal to, the center of the test door. If impossible to be so located, the nozzle shall be permitted to be on a line deviating not more than  $30^\circ$  from the line normal to the center of the test door. When so located, the distance from the center shall be less than  $20 \pm 0.3$  ft ( $6 \pm 0.1$  m) by an amount equal to  $1 \pm 0.015$  ft ( $0.3 \pm 0.005$  m) for each  $10^\circ$  of deviation from the normal.

12.12 Establish the water pressure at the base of the nozzle as prescribed in Table 2 for the desired rating.

12.13 One method to calculate the exposed area is using the outside dimensions of the test specimen, including a frame, hangers, tracks, or other parts of the assembly if provided, but normally not including the wall into which the specimen is mounted. Where multiple test specimens are mounted in the same wall, the rectangular or square wall area encompassing

TABLE 2 Water Pressure at Base of Nozzle and Duration of Application

Desired Rating (Fire Endurance Classification)	Water Pressure at Base of Nozzle, psi (kPa)	Duration of Application, s/ft <sup>2</sup> (s/m <sup>2</sup> ), Exposed Area
3 h and over	45 (310)	3.0 (32)
1½ h and over, if less than 3 h	30 (207)	1.5 (16)
1 h and over, if less than 1½ h	30 (207)	0.9 (10)
Less than 1 h	30 (207)	0.6 (6)

all of the specimens shall be considered as the exposed area since the hose stream must traverse this area during its application.

12.14 Direct the hose stream first at the bottom and then at all parts of the exposed surface, making changes in direction slowly. Keep the hose stream moving across the test assembly. Do not concentrate, make directional changes, or stop the hose stream on any point on the test assembly. Changes in direction of the hose stream shall be made within 1 ft (310 mm) outside of the perimeter edge of the door assembly. The following pattern complies:

12.14.1 Direct the hose stream around the periphery of the door assembly, starting upward from either bottom corner.

12.14.2 After the hose stream has covered the periphery, apply the hose stream in vertical paths  $1 \pm 0.5$  ft ( $305 \pm 152$  mm) apart until the entire width has been covered.

12.14.3 After the hose stream has covered the width, apply the hose stream in horizontal paths approximately  $1 \pm 0.5$  ft ( $305 \pm 152$  mm) apart until the entire height has been covered. If the required duration has not been reached, then repeat 12.14 in reverse.

12.15 Maintain the hose stream on the test assembly for the duration of application in seconds per square foot (seconds per square metre) of exposed area as prescribed in Table 2.

### 13. Conditions of Compliance

13.1 A door assembly complies with the requirements of this fire-test-response standard, when it remains in the wall for the duration of the fire endurance classification and hose-stream test within the following limitations (see X1.14).

13.1.1 The test assembly shall have withstood the fire endurance classification period and hose-stream test when conducted in accordance with 12.10, without developing through-openings anywhere on the door assembly. The following exceptions shall apply:

13.1.1.1 Portions of glass dislodged during the hose stream test shall not exceed 5 % of the area of the glass light.

13.1.1.2 The separation between meeting edges of pairs of doors in accordance with 13.5, 13.12, and 13.17 shall be considered acceptable.

13.1.1.3 The openings between the bottom edges of doors and sills in accordance with 11.3.1, 11.3.4, and 13.10 shall be considered acceptable.

13.1.2 No flaming shall occur on the unexposed surface of the test assembly during the classification period with the following exceptions:

13.1.2.1 During the first 5 min of the test, flaming at any one location for a cumulative total of less than 10 s is permitted around the door perimeter only.

13.1.2.2 After the first 5 min of the test, flaming at any one location for a cumulative total of less than 10 s is permitted around the door perimeter only.

NOTE 5—The exceptions to 13.1.2 are based on the use of sealing materials that may produce extremely small amounts of combustible gases that ignite and burn off as the sealing materials are activated.

13.1.3 When the cotton wool pad test is conducted, the door assembly shall not have allowed the passage of flames or hot gases sufficient to ignite the cotton wool pad.

13.1.4 This section is only applicable for classification periods equal to or greater than 3 h. Where hardware is evaluated for use on fire doors, it shall secure the door closed in accordance with the conditions of compliance. The latch bolt shall remain projected and be intact after the test. The hardware shall not be required to be operable following the test.

13.2 The movement of swinging doors shall not result in any portion of the edges adjacent to the door frame moving in a direction that is perpendicular to the plane of the door a distance from its original position that is greater than the thickness of the door during the entire classification period, or moving as a result of the hose stream test more than  $1\frac{1}{2}$  times the thickness of the door.

13.3 The movement of swinging doors mounted in pairs shall not result in any portion of the meeting edges moving from its original position a distance that is greater than the thickness of the door away from the adjacent door edge in a direction that is perpendicular to the plane of the doors during the entire classification period, or as a result of the hose stream test.

13.4 An assembly consisting of a pair of swinging doors incorporating an astragal shall not separate in a direction parallel to the plane of the doors by more than 0.75 in. (19 mm) or a distance equal to the throw of the latch bolt at the latch location.

13.5 An assembly consisting of a pair of swinging doors, without an overlapping astragal, with or without a resilient astragal, for a fire and hose stream exposure of  $1\frac{1}{2}$  h or less, shall not separate along the meeting edges by more than 0.375 in. (10 mm), including the initial clearance of the doors.

13.6 An assembly consisting of a single swinging door shall not separate by more than 0.5 in. (13 mm) at the latch location.

13.7 Door frames to be evaluated with swinging doors shall remain securely fastened to the wall on all sides and shall not permit through-openings between the frame and the doors or between the frame and the adjacent wall.

13.8 Sliding doors mounted on the face of the wall shall not move from the wall sufficiently to develop a separation of more than 2.875 in. (73 mm) during the entire classification period or as a result of the hose stream test.

13.9 Sliding doors mounted in guides shall not release from guides and guides shall not loosen from fastenings.

13.10 The bottom bar of rolling steel doors shall not separate from the floor structure by more than 0.75 in. (19 mm) during the entire classification period or as a result of the hose stream test.

13.11 The meeting edge of center-parting horizontal sliding doors and bi-parting vertical sliding doors shall not separate by a distance of greater than the door thickness measured in a direction perpendicular to the plane of the doors.

13.12 The meeting edges of center-parting horizontal sliding doors and bi-parting vertical sliding doors without an overlapping astragal, for a fire and hose stream exposure of  $1\frac{1}{2}$  h or less, shall not separate in a direction parallel to the plane of the doors by more than 0.375 in. (10 mm) along the meeting edges, including the initial clearance of the doors.

13.13 The meeting edges of center-parting horizontal sliding doors incorporating an astragal, shall not separate in a



direction parallel to the plane of the doors by more than 0.75 in. (19 mm) or a distance equal to the throw of the latch bolt at the latch location.

13.14 The bottom edge of service-counter doors or single-slide dumbwaiter doors shall not separate from the sill by more than 0.375 in. (10 mm).

13.15 A resilient astragal, if provided without an overlapping metal astragal, shall not deteriorate sufficiently to result in through-openings during the fire endurance test, but portions less than 10 % of the total area shall be permitted to be dislodged during the hose stream test.

13.16 The lap edges of horizontal slide-type elevator doors, including the lap edges of multi-section doors, shall not move from the wall or adjacent panel surfaces sufficiently to develop a separation of more than 2.875 in. (73 mm) during the entire classification period, or immediately following the hose stream test.

13.17 The meeting edges of center-parting horizontal slide-type elevator door assemblies, for a fire and hose stream exposure of 1½ h or less, shall not move apart more than 1.25 in. (32 mm) as measured in any horizontal plane during the entire classification period or immediately following the hose stream test.

#### 14. Report

14.1 Report results in accordance with the performance of the tests prescribed in this fire-test-response standard. The report shall include, but is not limited to, the following information:

14.1.1 The materials and the construction of the door and frame, and the details of the installation, hardware, hangers, guides, trim, finish, and clearance or lap shall be recorded or appropriately referenced to ensure positive identification or duplication in all respects.

14.1.2 The temperature measurements of the furnace.

14.1.3 All observations having a bearing on the fire endurance of the test assembly based on the length of time the door assembly complies with the requirements of Section 13 during the fire endurance test.

14.1.4 The amount of movement of any portion of the edges of the door adjacent to the door frame from the original position (see Section 13).

14.1.5 The pressure measurements made inside the furnace and the location of the probes.

14.1.6 The calculation showing the location of the neutral pressure plane in relation to the top of the door assembly during the test.

14.1.7 Flaming, if any, on the unexposed side of the door assembly.

14.1.8 The fire endurance classification obtained in accordance with the requirements of Section 13. Typical classifications are: 20 min, 30 min, 45 min, 1 h, 1½ h, 2 h, 3 h, or over in hourly increments.

14.1.9 The results of the hose stream test. When the hose stream test has not been performed on the 20-min door assembly, the report shall so indicate.

14.1.10 The laboratory's name, project number, date tested, sponsor, and a description of the laboratory test facility, including the furnace, test frame, and so forth.

14.1.11 The results of the cotton wool pad application or a statement why its application was not performed.

14.1.12 The temperature measurements of the unexposed side of the test assembly.

14.1.13 When only one side of an asymmetrical door is tested, describe the side exposed to the fire and the unexposed side. Explain why that condition was selected as the most onerous for the fire endurance classification.

#### 15. Precision and Bias

15.1 Precision and bias of this fire-test-response standard for measuring the response of door assemblies to heat and flame under controlled laboratory conditions are essentially as specified in Test Methods E 119. No information is presented about either the precision and bias of this test method for measuring the response of door assemblies to a standard hose stream under controlled laboratory conditions since the test is nonquantitative. No information is presented about either the precision and bias of this test method for measuring the response of door assemblies to the cotton wool pad test under controlled laboratory conditions since the test is nonquantitative.

#### 16. Keywords

16.1 classified; doors; fire; fire endurance; fire-rated assembly; fire-test-response standard; hose stream; positive pressure

**APPENDIX**
**(Nonmandatory Information)**
**X1. COMMENTARY**
**X1.1 Introduction**

X1.1.1 This commentary has been prepared to provide the user of this fire-test-response standard with background information on the development of the standard and its application in fire protection of buildings. It also provides guidance in the planning and performance of fire tests and in the reporting of results. No attempt has been made to incorporate all of the available information on fire testing in this commentary. The serious student of fire testing is strongly urged to pursue the reference documents for a better appreciation of the history of fire-resistant design and the intricate problems associated with testing and with interpretation of test results.

**X1.2 Application**

X1.2.1 Compartmentation of buildings by fire-resistive walls has been recognized for many years as an efficient method of restricting fires to the area of origin **(1-9)**<sup>7</sup> or limiting their spread. The functional use of buildings however, demands a reasonable amount of communication between compartments necessitating openings in these fire-resistive walls. Fire door assemblies are utilized to protect these openings and maintain the integrity of the fire barrier **(10)**. Openings in walls have been classified by fire protection standards **(6, 11, 12)** and building codes in accordance with the location and purpose of the wall in which the opening occurs, and these standards and codes specify the fire rating of the assembly required to protect the openings.

X1.2.2 These fire protection standards and building codes permit labeled wire glass panels and other penetrations, such as labeled ventilation louvers, in some rated doors. The reader is referred to the model building codes, NFPA Standard No. 80 **(6)**, and the specific fire door manufacturer's label service for information on the types and sizes of these openings.

X1.2.3 Fire doors must also be properly installed to maintain their fire rating. Again, it is recommended that NFPA Standard No. 80 and the specific fire door manufacturer's label service be consulted for details on the installation of fire door assemblies and for limitations on the application of specific labeled fire doors.

**X1.3 Historical Aspects**

X1.3.1 The first effort to test fire doors is reported in a series of tests conducted in Germany in 1893 **(13, 14, 15)**. The British Fire Prevention Committee began testing in 1899 and produced a Standard Table of Fire Resisting Elements including Fire Resisting Doors **(1)**. Underwriters Laboratories Inc. was involved in testing and listing fire doors shortly after 1900 using their own standards. ASTM adopted Methods E 152 on fire door assembly tests in 1941.

<sup>7</sup> The boldface numbers in parentheses refer to the list of references at the end of this standard.

**X1.4 Scope and Significance**

X1.4.1 This fire-test-response standard is intended to provide methods for measuring the relative fire endurance of fire door assemblies when exposed to predetermined standard fire conditions. The standard provides for testing of several classifications, types, and methods of door operation including swinging, sliding, rolling, and sectional doors **(6)**. Since the effectiveness of the opening protection is dependent upon the entire assembly, proper attention must be paid to the installation as a unit. Accordingly, fire door assemblies are required to be tested as an assembly of all necessary elements and equipment, including the door frame and hardware.

X1.4.2 Fire protection ratings are assigned to indicate that the assembly has continued to perform as required for periods of 3, 1½, 1, ¾, ½, or ⅓ h. Labels on assemblies also used to carry the lettered designations of A, B, C, D, or E. These letter designations are not a part of this fire-test-response standard classification system but were used to designate the class of opening for which the door is designed as determined by other standards **(6, 11)**.

X1.4.3 The ⅓-h or 20-min fire-rated door is relatively new. Concern about the uniform adequacy of the 1¾-in. (44.5-mm) solid bonded wood core construction and the difficulty of determining equivalency of other types of doors, led to a voluntary consensus. It was agreed to test such doors for 20 min using the same acceptance criteria as specified for door assemblies traditionally tested for a longer period of time with one exception; that being, the hose stream test is required by this test method but possibly not always be required by regulatory codes.

X1.4.4 It is usual for a fire door to have a fire-protection rating lower than the wall in which it is installed, for example, a 1½-h fire door in a wall having a fire-resistance rating of 2 h. This is justified by the fact that under normal conditions of use the potential fire exposure in the vicinity of a door opening is lessened since there will be a clear space on both sides of the opening for traffic purposes. When combustibles are piled against doors not in use, the assumed enclosure protection is no longer maintained. It is recommended that in these instances, the openings be made equal to the rating of the wall or precautions taken to prevent storage of combustibles against the doors **(2,6)**.

**X1.5 Limitations**

X1.5.1 This fire-test-response standard intends that the door be tested until the conditions of compliance are met for the desired exposure period unless the conditions of compliance are exceeded in a shorter period. It is not intended that a fire door subjected to a building fire will be satisfactory for reuse after the fire.

X1.5.2 The variations in material performance preclude any prediction of an assembly's fire endurance in walls other than

those types used in the test. The standard also makes no provisions for measuring the generation of smoke and gases or other products of combustion from the unexposed side of the door. Temperature measurements on the unexposed side are recorded every 1 min during the first 30 min.

### **X1.6 Furnace**

X1.6.1 This fire-test-response standard provides details on the operating characteristics and temperature-measurement requirements of the test furnace. It is recommended that the walls of the furnace be typically of furnace-refractory materials and be sufficiently rugged to maintain the overall integrity of the furnace during the fire-exposure period.

X1.6.2 The thermocouples in the furnace are located 6 in. (152 mm) from the face of the door or the wall in which the door is installed. Otherwise no furnace depth is specified. A depth of 8 to 18 in. (203 to 457 mm) has been considered desirable by most laboratories. The reader is urged to consult reference documents for a more comprehensive review of furnace design and fire endurance (16, 17).

### **X1.7 Temperature-Time Curve**

X1.7.1 A specific time-temperature relationship for the test fire is defined in this standard. The actual recorded time-temperature condition obtained in the furnace is required to be within the specified percentages of those of the standard curve. The number and type of temperature-measuring devices are outlined in the standard. Specific standard practices for location and use of these temperature-measuring devices are also outlined in the standard.

X1.7.2 The standard time-temperature ( $T - t$ ) curve used in Test Methods E 152 is considered to represent a severe building fire (3). The curve was adopted in 1918 as a result of several conferences by eleven technical organizations, including testing laboratories, insurance underwriters, fire protection associations, and technical societies. Understand that the  $T - t$  relationship of these test methods represent only one real fire situation (7-9, 18-27).

### **X1.8 Furnace Control**

X1.8.1 This fire-test-response standard contains specific instruction for measuring temperatures in the furnace and for selection of the required thermocouples. Thermocouples of the design specified are sufficiently rugged to retain accuracy throughout anticipated test periods. However, their massive construction results in a significant time delay in response to temperature change and results in temperatures exceeding the indicated temperatures during the early stages of the test period when the temperature rises rapidly. The iron or porcelain tubes surrounding the junction and leads of the thermocouple provide a shield against degradation of the junction and increase the thermal inertia. It is customary for laboratories to replace furnace thermocouples after three or four accumulated hours of use.

### **X1.9 Unexposed Surface Temperature**

X1.9.1 Conditions of compliance for fire-resistive walls specify that the temperature increase on the unexposed side of the wall not exceed an average of 250°F (139°C) above

ambient, and that there be no passage of flames or gases hot enough to ignite combustibles. It is obvious that the necessity of maintaining some clearances for efficient operation of the door and the possibility of warping preclude completely any attempt to restrict escape of gases and minor flames on the periphery of doors.

X1.9.2 This fire-test-response standard describes a standard procedure for measuring the unexposed surface temperatures. However, unexposed surface temperatures are not a condition of acceptance for this fire-test-response standard. Building regulations do restrict temperature transmission for some wall-opening protectives (6, 11). For instance, it is usual for codes to limit the temperature rise on the unexposed side of fire doors protecting exit stairways to 450°F (250°C) during the first 30 min of the test. This criterion assumes that a higher temperature would provide enough radiant heat to discourage if not prevent occupants from passing by the door during an emergency. It is present practice for testing laboratories to provide labels on fire doors indicating that the maximum transmitted temperature on the unexposed side is 250°F, 450°F, or 650°F (139°C, 250°C, or 361°C) above ambient. If not indicated on the label, the temperature rise during the first 30 min is possibly in excess of, or less than, 650°F (361°C). Temperature on the unexposed side of glass panels and louvers is not measured.

X1.9.3 Information on the properties of pads used to cover the thermocouples on the unexposed surfaces are stated in this fire-test-response standard.

### **X1.10 Test Assemblies**

X1.10.1 This fire-test-response standard provides a relative measure of fire endurance for door assemblies. In order to establish confidence that the tested doors will perform in a building as expected, the tested assembly and its installation in the test frame must be representative of actual use conditions.

X1.10.2 This fire-test-response standard provides additional minimum requirements including direction of door swing, location in relation to the exposed side of the wall, and specific clearance between the door and its frame or wall, or both. Regardless of other specifications, these instructions must be followed in order to make a comparative judgment on test results.

### **X1.11 Conduct of Tests**

X1.11.1 It is recommended that the test frame or wall in which a door assembly is installed be rugged enough to endure the exposed fire during the time period, without affecting the door assembly. Traditionally, this wall has been of masonry construction. Today, fire doors are installed in other than masonry walls and have been tested in walls framed with metal and wood studs covered with a number of materials.

### **X1.12 Furnace Pressures**

X1.12.1 A fire in a building compartment will create both negative and positive pressures on door assemblies depending upon atmospheric conditions, height above ground, wind conditions, and ventilation of the compartment at the beginning and during the fire.

X1.12.2 Methods E 152<sup>7</sup> had specified that the pressure in the furnace be maintained as nearly equal to atmospheric pressure as possible. However, positive pressure is required by some regulatory agencies. The pressure in the furnace is required to be reported and the method of measuring it is also detailed in this standard.

### X1.13 Hose Stream Test

X1.13.1 Immediately following a fire test, the test frame is removed from the furnace and the door assembly is subjected to the impact, erosion, and cooling effects of a stream of water. The application of water produces stresses in the assembly and provides some measure of its structural capability. Weights were once used to provide a measure of the ability of the

assembly to withstand impact. The hose stream is considered to be an improvement in uniformity and accuracy over the weights.

### X1.14 Conditions of Compliance

X1.14.1 This fire-test-response standard provides a specific set of conditions by which the fire endurance of the door is measured, the most important being that it remain in place during both the fire test and the hose stream test. Instructions for conducting the hose stream test are detailed in the standard.

### X1.15 Additional Information

X1.15.1 Address inquiries concerning this fire-test-response standard to ASTM Subcommittee E05.11.

## REFERENCES

- (1) Bird and Docking, *Fire in Buildings*, D. VanNostrand Co., Inc., New York, NY, 1949.
- (2) Ferguson, R.S., *Principles of Fire Protection, National Bldg. Code of Canada Technical Paper No. 272*, Division of Building Research, National Research Council of Canada, Ottawa, March 1970.
- (3) Gordon, C., "Considerations of Life Safety and Building Use," *DBR Paper No. 699*, Division of Building Research, National Research Council of Canada, Ottawa, January 1977.
- (4) Gross, D., *Field Burnout Tests of Apartment Dwelling Units, Building Science Series 10*, U.S. Dept. of Commerce, National Bureau of Standards, Sept. 29, 1967.
- (5) Law, Margaret, "Radiation from Fires in a Compartment," *Fire Research Technical Paper No. 20*, Her Majesty's Stationary Office, London, 1968.
- (6) NFPA 80, "Fire Doors and Windows," National Fire Protection Assn.
- (7) Harmathy, T.Z., "Designers Option: Fire Resistance or Ventilation," *Technical Paper No. 436*, Division of Building Research, National Research Council of Canada, Ottawa, NRCC 14746.
- (8) Harmathy, T.Z., "Design Approach to Fire Safety in Buildings," *Progressive Architecture*, NRCC 14076, April 1974, pp. 82-87.
- (9) Harmathy, T.Z., "A New Look of Compartment Fires Part I and Part II," *Fire Technology*, Vol 8, No. 3 and No. 4, 1972, pp. 196-217; 326-351.
- (10) Shoub, H., and Gross, D., *Doors as Barriers to Fire and Smoke, Building Science Series 3*, National Bureau of Standards, March 25, 1966.
- (11) Model Building Codes; *Basic Building Code*—Building Officials & Code Administrators International Inc.; *Uniform Building Code*—International Conference of Building Officials Inc.; *Standard Building Code*—Southern Building Code Congress International; *National Building Code*—American Insurance Assn.
- (12) *Fire Protection Handbook*, revised 14th ed., National Fire Protection Assn., Boston, 1978.
- (13) Shoub, Harry, "Early History of Fire Endurance Testing in the United States," *Symposium on Fire Test Methods, ASTM STP 301*, ASTM, 1961.
- (14) Konicek, L., and Lie, T.T., *Temperature Tables for Ventilation Controlled Fires, Building Research Note No. 94*, National Research Council of Canada, September 1974.
- (15) Babrauskas, Vytenis, Williamson, Robert Brady, "Historical Basis of Fire Resistance Testing, Part I and Part II," *Fire Technology*, Vol 14, No. 3 and No. 4, 1978, pp. 184-194, 304-316.
- (16) Seigel, L.G., "Effects of Furnace Design on Fire Endurance Test Results," *Fire Test Performance, ASTM STP 464*, ASTM, 1970, pp. 57-67.
- (17) Harmathy, T.Z., "Design of Fire Test Furnaces," *Fire Technology*, Vol 5, No. 2, May 1969, pp. 146-150.
- (18) Seigel, L.G., "The Severity of Fires in Steel-Framed Buildings," *Symposium No. 2*, Her Majesty's Stationery Office, 1968, London, *Proceedings of the Symposium Held at the Fire Research Station Boreham Woods, Herts (England)*, January 1967.
- (19) Odeen, Kai, "Theoretical Study of Fire Characteristics in Enclosed Spaces," *Bulletin No. 10*, Royal Institute of Technology, Division of Building Construction, Stockholm, 1963.
- (20) Shorter, G.W., "Fire Protection Engineer and Modern Building Design," *NFPA Fire Technology*, Vol 4, No. 3, August 1968, pp. 206-213.
- (21) *Wall Street Journal*, Dec. 8, 1970, "Danger-Flammable," by-line Richard Stone.
- (22) Ryan, J.E., "Assessment of Fire Hazards in Buildings," *Ignition, Heat Release, and Noncombustibility of Materials, ASTM STP 502*, ASTM, 1972.
- (23) Robertson, A.F., and Gross, Daniel, "Fire Load, Fire Severity, and Fire Endurance," *Fire Test Performances, ASTM STP 464*, ASTM, 1970.
- (24) Heselden, A.J.M., *Parameters Determining the Severity of Fire, Symposium No. 2*, Her Majesty's Stationery Office, 1968, London, *Proceedings of the Symposium Held at the Fire Research Station Boreham Woods, Herts (England)*, January 1967.
- (25) Gross, Daniel, and Robertson, A.F., *Experimental Fires in Enclosures, Tenth Symposium (International) on Combustion*, The Combustion Institute, 1965, pp. 731-942.
- (26) Ingberg, et al, *Combustible Contents in Buildings*, National Bureau of Standards, BMS 149, July 1957.
- (27) Harmathy, T.Z., "Performance of Building Elements in Spreading Fire," *DBR Paper No. 752*, National Research Council of Canada, NRCC 16437, *Fire Research*, Vol 1, 1977/78, pp. 119-132.
- (28) National Door Fire Test Project: Positive Pressure Furnace Fire Tests, NFPRF, Quincy, MA, 1995. Prepared by M. van Geyn, Warnock Hersey Professional Services Ltd.
- (29) National Door Fire Test Project: Positive Pressure Room Burn Tests, NFPRF, Quincy, MA, 1995. Prepared by P.D. Gandhi and D.T. Sheppard, Underwriters Laboratories Inc.
- (30) National Door Fire Test Project: Induced Failure Mode Tests, NFPRF, Quincy, MA, 1995. Prepared by P.D. Gandhi, H.J. Gruszynski, and D.T. Sheppard, Underwriters Laboratories Inc.



*ASTM International takes no position respecting the validity of any patent rights asserted in connection with any item mentioned in this standard. Users of this standard are expressly advised that determination of the validity of any such patent rights, and the risk of infringement of such rights, are entirely their own responsibility.*

*This standard is subject to revision at any time by the responsible technical committee and must be reviewed every five years and if not revised, either reapproved or withdrawn. Your comments are invited either for revision of this standard or for additional standards and should be addressed to ASTM International Headquarters. Your comments will receive careful consideration at a meeting of the responsible technical committee, which you may attend. If you feel that your comments have not received a fair hearing you should make your views known to the ASTM Committee on Standards, at the address shown below.*

*This standard is copyrighted by ASTM International, 100 Barr Harbor Drive, PO Box C700, West Conshohocken, PA 19428-2959, United States. Individual reprints (single or multiple copies) of this standard may be obtained by contacting ASTM at the above address or at 610-832-9585 (phone), 610-832-9555 (fax), or [service@astm.org](mailto:service@astm.org) (e-mail); or through the ASTM website ([www.astm.org](http://www.astm.org)).*