



Standard Test Method for Thermal EMF Test of Single Thermoelement Materials by Comparison with a Reference Thermoelement of Similar EMF-Temperature Properties¹

This standard is issued under the fixed designation E207; the number immediately following the designation indicates the year of original adoption or, in the case of revision, the year of last revision. A number in parentheses indicates the year of last reapproval. A superscript epsilon (ε) indicates an editorial change since the last revision or reapproval.

^{ε1} NOTE—Editorial changes were made throughout in June 2015.

1. Scope

1.1 This test method covers a test for determining the thermoelectric emf of a thermoelement versus NIST platinum 67 (Pt-67) by means of measuring the difference between the emf of the test thermoelement and the emf of a reference thermoelement (previously referred to as a secondary standard), which has a known relationship to NIST Pt-67.

1.2 This test is applicable to new thermocouple materials over the temperature ranges normally associated with thermocouples and their extension wires. The table on Suggested Upper Temperature Limits for Protected Thermocouples in Specification E230 lists the ranges associated with the letter-designated types of thermocouples. *ASTM MNL-12*² lists the temperature range of extension circuit materials.

1.3 This test is not applicable to stability testing or inhomogeneity testing.

1.4 The values stated in SI units are to be regarded as the standard. The values given in parentheses are for information only.

1.5 *This standard does not purport to address all of the safety concerns, if any, associated with its use. It is the responsibility of the user of this standard to establish appropriate safety and health practices and determine the applicability of regulatory limitations prior to use.*

2. Referenced Documents

2.1 ASTM Standards:³

¹ This test method is under the jurisdiction of ASTM Committee E20 on Temperature Measurement and is the direct responsibility of Subcommittee E20.04 on Thermocouples.

Current edition approved May 1, 2015. Published May 2015. Originally approved in 1962. Last previous edition approved in 2008 as E207 – 08. DOI: 10.1520/E0207-08R15E01.

² *Manual on the Use of Thermocouples in Temperature Measurement, ASTM MNL-12*, Fourth Edition, ASTM, April 1993. (Revision of STP 407B).

³ For referenced ASTM standards, visit the ASTM website, www.astm.org, or contact ASTM Customer Service at service@astm.org. For *Annual Book of ASTM Standards* volume information, refer to the standard's Document Summary page on the ASTM website.

- E77 Test Method for Inspection and Verification of Thermometers
- E220 Test Method for Calibration of Thermocouples By Comparison Techniques
- E230 Specification and Temperature-Electromotive Force (EMF) Tables for Standardized Thermocouples
- E344 Terminology Relating to Thermometry and Hydrometry
- E563 Practice for Preparation and Use of an Ice-Point Bath as a Reference Temperature

3. Terminology

3.1 *Definitions*—The terms used in this test method are defined in Terminology E344.

3.2 *Definitions of Terms Specific to This Standard:*

3.2.1 *reference facility, n*—NIST, or a testing laboratory whose physical standards are traceable to NIST or another national standards laboratory.

3.2.2 *test temperature, n*—the temperature of the measuring junction.

3.2.2.1 *Discussion*—In reporting the results, the value of the test temperature may be rounded off, provided the stated test temperature is within the bounds indicated in 10.10.

4. Summary of Test Method

4.1 The emf of a thermoelement sample is determined by comparison to a reference thermoelement that has similar Seebeck coefficients.

4.2 This test is conducted on one or more lengths of specimens connected to a single length of the reference thermoelement at a single point. The joined ends are held at the test temperature, and their opposite ends are held at a constant reference temperature.

4.3 The emf of the reference thermoelement relative to Pt-67 at several test temperatures are provided by a reference facility.

4.4 The emf of the test thermoelement relative to Pt-67 is determined by algebraically adding the measured emf to the emf of the reference thermoelement at each test temperature.

5. Significance and Use

5.1 This test method is designed to calibrate a thermoelement at one or more test temperatures. The data obtained are sometimes referred to as initial values of emf because the time at the test temperature is limited.

5.2 This test method is employed mainly by providers of spools or coils of wire or strips of thermoelectric material. Generally more than one specimen at a time is tested, and the resultant emfs of individual thermoelements are used to match to companion thermoelements for use as thermocouples or in extension wiring.

5.3 The emf of a thermocouple comprised of two different thermoelements as tested with this test method may be determined by algebraically subtracting the emf of the negative thermoelement from the emf of the positive thermoelement at a particular temperature. The emf of a thermocouple may also be determined by the test described in Test Method E220, but Test Method E220 does not take into account the values of the emf of the individual thermoelements relative to Pt-67.

5.4 This test method is normally used for the calibration of thermocouple materials during their production or distribution, not for the accurate determination of the properties of a used thermocouple. If the test samples were subjected to previous use, the test results may not reflect the same emf as the thermocouple did while in service. For example, inhomogeneities may have been induced in the wires because of a chemical or metallurgical reaction while in service. Since emf is developed in the thermal gradient, and it is unlikely that the temperature profile along the wire under testing conditions will be the same as it was while in service, the test results may be misleading.

5.5 The test results are suitable for specification acceptance, manufacturing control, design, or research and development purposes.

6. Test Specimen

6.1 Each sample shall represent one continuous spool, coil, or strip of thermoelectric material. The sample shall consist of two specimens, one cut from each end of the spool, coil, or strip. The extreme ends shall not be acceptable if they are distorted or have been subjected to processing dissimilar to the bulk of the spool, coil, or strip.

6.2 Insulation or covering shall be removed with care if it interferes with the test. Straining the test specimen shall be avoided.

6.3 The specimens shall be cleaned of any extraneous surface contamination.

6.4 The specimens and the reference thermoelement shall be long enough to extend continuously from the measuring junction to the reference junction. A length of 600 to 1200 mm (2 to 4 ft) is generally satisfactory. The exact length depends upon the depth of immersion in the testing medium and the

transverse size (for example, diameter of round wire, width of strip) of the thermoelement.

6.4.1 Heating of the measuring junctions shall not affect the temperature of the reference junctions during the period of test.

7. Reference Thermoelement

7.1 The reference thermoelement has its emf established relative to NIST Pt-67 over the temperature range of its intended use. A specific lot of thermoelement material is usually reserved for use as reference thermoelements.

7.2 The emf of the reference thermoelement versus platinum (Pt-67) shall conform to Specification E230 within one half the standard tolerance specified for the related thermocouple type. For example, the tolerance for KP versus Pt-67 is $\pm 1^\circ\text{C}$ or $\pm 0.375\%$ of temperature from 0 to 1260°C , whichever is greater.

7.3 The cross section of the base metal thermoelement shall be sufficiently large so that oxidation caused by the temperatures of testing would not significantly affect its emf over the period of the test.

7.4 To provide some assurance that the reserved lot is uniform in emf from end to end, it shall be manufactured in one continuous length with no in-process welds. Cold working of the material after the final anneal shall be minimized.

7.4.1 A specimen from each end of the reserved lot shall be tested using this test method. The test temperatures shall include the extremes of the intended range of use and additional test points that are no more than 260°C (500°F) apart.

7.4.2 The emf difference between the specimens of 7.4.1 at each test temperature shall not exceed the equivalent of 0.33°C (0.6°F) for that thermocouple type or 0.05 % of the value of the test temperature in degrees Celsius, whichever is the greater.

7.5 From the lot that meets the stated uniformity requirements, at least one unused 1 m (3-ft) section shall be certified by a reference facility to document its emf relative to Pt-67. Traceability shall be required in the form of a certificate issued by the reference facility.

7.5.1 Emf data shall be provided every 50°C (100°F) or at intervals that do not exceed 25 % of the test temperature range, whichever is the lesser. If fewer than the aforementioned number of points are taken, then the data are applicable only at or near the measured temperatures, and interpolation beyond them should not be attempted.

7.5.2 The emf of the reference thermoelement at intermediate values of temperature may be determined by one of the following methods.

7.5.2.1 For the letter-designated thermocouple types, emf functions for thermoelements versus Pt-67 are given in Specification E230. In these cases, the deviation of the reference thermoelement emf from the function value is first calculated at the test temperatures. At an intermediate temperature, the deviation of emf is calculated either by linear interpolation or by fitting a polynomial to the deviation of emf using the method of least squares, and evaluating the polynomial at the intermediate temperature. For the least squares method, the number of data points shall equal or exceed twice the number of parameters fitted. Addition of the deviation of emf to the

function value at the intermediate temperature gives the emf value of the reference thermoelement at the intermediate temperature.

7.5.2.2 For the thermoelements for which there is no emf function for that thermoelement versus Pt-67, a function may be determined by fitting a polynomial to the emf values reported by NIST for the reference thermoelement versus Pt-67, using the method of least squares. The number of data points shall equal or exceed twice the number of parameters fitted. Evaluation of the polynomial at the intermediate temperature gives the emf of the reference thermoelement. In cases where the deviations of the fitted data from the polynomial are significant compared to other uncertainties in the test, a subcomponent of uncertainty shall be added to the uncertainty budget equal to:

$$u = \sqrt{\left[\frac{1}{N_{df}} \sum_i (E_i - E_{fit})^2 \right]} \quad (1)$$

where:

- u = uncertainty,
- E_i = the emf at the i th calibration temperature value of the reference thermoelement that has been calibrated relative to NIST Pt-67,
- E_{fit} = the emf of the fitted polynomial, and
- N_{df} = the number of degrees of freedom in the fit = number of data points – number of fitted parameters.

7.5.2.3 Linear interpolation of the reference thermoelement emf, rather than the deviation of emf, may also be done, but use of this method requires inclusion of an additional uncertainty component to account for the interpolation error. This uncertainty component may be estimated by calculating the error of linear interpolation of the emf values obtained from the emf functions for thermoelements versus Pt-67 in Specification E230 or another source. This error may be as large as all other errors combined.

7.6 The segment of reference thermoelement that is used for each test shall be unaffected by a prior test. For example, any segment of a KP, EP, or JP thermoelement, exposed to temperatures exceeding 260°C (500°F) shall not be reused. However, if it shows no evidence of its test environment and no effects of strain, the remainder may be reused. For noble metals and their alloys, the number of reuses depends upon the amount of strain or contamination of the segment. Noble metal reference thermoelements should be checked for emf conformity after ten uses or less against another noble metal reference segment that was not subjected to routine use.

8. Reference Temperature Unit

8.1 The reference temperature unit shall maintain the temperature of the reference junctions within 5°C (9°F) of the assumed value of reference temperature. The reference temperature unit shall be designed so that the temperatures of all the reference junctions will be isothermal.

NOTE 1—The preferred reference junction temperature is 0°C (32°F). This may be approximated with an ice bath (see Practice E563), “automatic ice point” unit or a “zone box” (see MNL-12). Care should be exercised to maintain the reference junction temperatures for both the reference and test thermocouples at the same temperature.

9. Measuring Junction

9.1 The measuring junction shall consist of an electrical connection of the test specimens at one of their ends to the reference thermoelement. Welding is the preferred method of joining, particularly for test temperatures above 260°C (500°F).

9.2 The number of test specimens that may be tested at one time is limited mainly by the thermal capacity of the system. The thermal conduction along the assembly of test thermoelements shall not be so large as to impair isothermal conditions at the measuring or reference junction.

10. Test Temperature Medium

10.1 Normally, both the test and reference thermoelements have the same nominal composition and consequently have approximately the same values of Seebeck coefficients. Therefore, the measured emf is expected to be small in magnitude (compared to the emf relative to Pt-67) and vary only slightly as a function of temperature. Therefore, it is not necessary to control the test temperature precisely.

10.2 The immersion media, insulation materials, supports, and adjacent materials shall not interact with or electrically shunt the thermoelements.

10.3 For testing in the range of –160 to –75°C (–250 to –100°F), a liquid nitrogen bath may be used. Refer to the devices and precautions in Test Method E77, Appendix X1, on Discussion of Apparatus for Verification of Liquid-in-Glass Thermometers and Fig. X1.3 on Comparator for Temperature Range from –160 to –75°C (–256 to –103°F).

10.4 For testing in the range of –80 to +5°C (–110 to +40°F), use an apparatus as depicted in Test Method E77, Appendix X1, on Discussion of Apparatus for Verification of Liquid-in-Glass Thermometers and Fig. X1.4 on Comparator for Temperature Range from –80 to +5°C (–112 to +41°F), using dry ice and a suitable liquid.

10.5 For testing in the range of room temperature to 95°C (200°F), a heated bath using demineralized water may be used.

10.6 In the range of 5 to 300°C (40 to 600°F), a stirred bath of an oil with a flash point higher than the test temperature may be used. Refer to Test Method E77, Appendix X1, on Discussion of Apparatus for Verification of Liquid-in-Glass Thermometers and Fig. X1.6(b) on Alternative Designs.

10.7 For testing at or above 100°C (200°F), an electrically-heated laboratory-type wire-wound tube furnace is generally used. The atmosphere inside the tube shall be air, and the ends shall not both be sealed airtight. Other atmospheres may be used as agreed upon between the producer and purchaser.

10.8 In the range of –70°C (–90°F) to as high as 1150°C (2100°F), a suitable bath consisting of a fluidized bed of non-conductive refractory oxide may be used.

NOTE 2—For convenience, a separate unit may be made available for each test temperature. This eliminates time lost to change the temperature of the test temperature medium, particularly when a large volume of testing is to be done.

10.9 The test temperature medium shall provide a uniform temperature zone (see 10.10) extending back from the measuring junction to at least five times the combined diameter of the test specimens.

10.10 The temperature of each test medium shall be controlled manually or automatically so that any point inside the zone of uniformity shall be within 10°C (18°F) of the desired test temperature.

10.10.1 The test temperature value shall be indicated by a temperature monitoring device or by the control system itself. The temperature sensor shall be positioned within the zone of uniformity. The sensor and the monitoring device should be recalibrated periodically or before each use.

11. Emf Indicator

11.1 The emf that is developed between the test specimen and the reference thermoelement at each test temperature shall be determined with a voltmeter capable of resolving 1 μ V. It shall have an uncertainty not exceeding 3 μ V. Because the emf values generally fall within a few hundred μ V of zero, the emf indicator should not drift more than 3 μ V during the time of each set of measurements. The emf indication system shall be calibrated immediately before use, or on a periodic basis.

11.2 The voltmeter shall have an input resistance of at least 1000 times the resistance of the circuit it is measuring. Generally, 1 M Ω is sufficient.

NOTE 3—Appendix X1 describes the preferred emf recording system for multiple specimens taken to several test temperatures.

12. Procedure

12.1 Remove any surface oxide from the ends of the test specimens by sanding, filing, or wire brushing to ensure a reliable electrical contact or an intact weld.

12.2 After ensuring that the reference thermoelement and all test thermoelements are clean and visually free of any contamination, join them as described in Section 9. All thermoelements, both test subjects and reference, shall be electrically isolated along their entire lengths between the measuring and reference junctions. The thermoelement shall be continuous between the measurement and reference junctions; Extension thermoelements or connectors may interfere with proper measurement.

NOTE 4—Various types of insulators may be used to electrically shield the thermoelements. Insulators include, but are not limited to, ceramics, polymers, and air separation.

12.3 If necessary, bend the reference thermoelement and test specimens a minimum amount to allow insertion into the respective temperature medium. The bend shall not be subjected to a temperature gradient.

12.4 If an ice-point unit or bath is used, join the free end of each thermoelement to the bare tip of a pure copper wire to form a reference junction. The copper wire shall be coated with an electrically insulating, water-resistant material to avoid touching the thermoelement at any other point. To prepare the reference junction, make the electrical connection between each individual thermoelement and its respective copper lead using a screw or spring connector, or by soldering, welding, or

crimping, or any other suitable means. These connections are then placed into individual clean glass tubes. As stated in Test Method E220 care must be taken to keep thermal conduction losses within the limits of experimental error typically by immersing the thermoelement-copper lead pair into the ice-point unit or bath until no further change in indicated emf is noted. Alternatively, the electrical connection may be made by immersing the thermoelement and the copper wire into a pool of mercury which is maintained at the reference junction temperature. (**Warning**—Mercury has been designated by EPA and many state agencies as a hazardous material that can cause central nervous system, kidney and liver damage. Mercury or its vapor may be hazardous to health and corrosive to materials. Caution should be taken when handling mercury and mercury-containing products. See the applicable product Material Safety Data Sheet (MSDS) for details and EPA’s website (<http://www.epa.gov/mercury/faq.htm>) for additional information. Users should be aware that selling mercury, mercury-containing products, or both in your state may be prohibited by state law.)

12.4.1 The copper wires shall be 20 AWG [0.8 mm] or of lesser diameter and may be as long as necessary to reach the emf indicator.

12.5 Shield, cover, or enclose the reference temperature unit when alternate reference temperature units are used to promote temperature uniformity.

12.6 The copper wires or conductors associated with the thermoelements under test shall be sequentially connected to the “high” or positive input terminal of the emf indicator. The conductor associated with the reference thermoelement shall be connected to the “low” or negative input terminal of the emf indicator. Fig. 1 illustrates the basic circuit schematic.

12.7 Bring the temperature of the test medium to the specified value of the test temperature and allow it to stabilize. That is, the test medium shall come to a temperature equilibrium within the limits indicated in 10.10. Allow the emf indicator and associated equipment to stabilize. If necessary, adjust the emf indicator to read zero with its input terminals shorted.

12.8 Immerse the measuring junction of the test assembly into the zone of temperature uniformity of the test medium, and place the opposite ends in the reference temperature unit. Provide sufficient time for the test assembly to reach steady-state thermal conditions. Avoid maintaining the test assembly at a high test temperature for a prolonged period because that may cause the thermoelements to undergo a metallurgical or chemical change. Generally, 10 min is satisfactory. Do not exceed 20 min at each temperature of 260°C (500°F) or higher.

12.9 Record the value of the temperature at the measurement junction.

12.10 Check the temperature of the reference media.

12.11 Record the emf generated between each of the test specimens in the assembly with respect to the reference thermoelement by means of the switching device.

12.12 Take the test assembly to the next test temperature quickly (faster than 6°C (10°F) per minute).

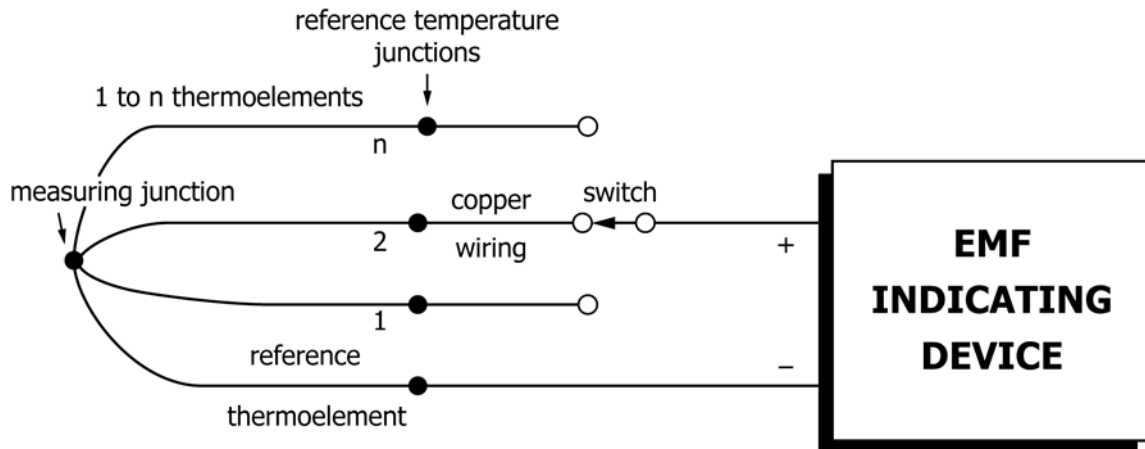

FIG. 1 Thermoelectric emf Test, Basic Circuit Diagram

12.12.1 If multiple furnaces or baths are used, insert the test assembly into the unit operating at the next test temperature. Ideally, the depth of immersion shall be the same throughout the test. Otherwise the depth shall not be less than any previous immersion, especially at temperatures above 260°C (500°F) for Types KP, EP, or JP.

12.13 Repeat steps in 12.8 – 12.12, taking readings at all specified test temperatures. For base metals, proceed from the lowest to the highest test temperature and avoid overshooting above 260°C (500°F).

13. Calculation and Report

13.1 The goal of this thermoelement comparison test is to obtain the calibration of the test thermoelement, (*x*), expressed relative to NIST Pt-67 (*p*) and referenced to $T_i = 0^\circ\text{C}$ (32°F). The calibrated relative emf value, E_{xp} , for each test temperature, T_t , shall be calculated by:

$$E_{xp} = E_{rp} + E_{xr} \quad (2)$$

where:

- E_{rp}] T_t = the emf of the reference thermoelement (*r*) that has been calibrated relative to NIST Pt-67, and
- E_{xr}] T_i = the measured emf for the tested thermoelement relative to the reference thermoelement, when their common junction is at the test temperature, T_t , and their reference junctions are at the ice point,

13.1.1 The test temperature term may be rounded off to within the limits of 10.10, relative to the actual value of the test temperature. The emf of the reference thermoelement shall be the certified value at the rounded-off temperature value. The

general practice is to express the emf in millivolts at each value of test temperature (in degrees Fahrenheit or Celsius) in the report.

13.1.2 *Example*—To determine the emf for a Type JN alloy with a test temperature of 500°C and a reference junction 0°C:

- (1) The emf between the reference thermoelement and Pt-67 at 500°C = -20.710 mV
- (2) The measured emf between the test specimen and the reference thermoelement at 500°C = + 0.015 mV
- (3) The resultant emf between the test specimen and Pt-67 = -20.695 mV

13.2 When the test data are obtained using a reference temperature other than 0°C, and the emf between 0°C and the reference temperature of the test thermoelements versus the reference thermoelements has been determined, calculate the emf value, E_{xr} , for each test temperature, T_t , by:

$$E_{xr} = E_{xr} + E_{xr} \quad (3)$$

where:

- E_{xr}] T_t = the emf measured between the reference and test temperatures, and
- E_{xr}] T_i = the emf measured between 0°C and the alternate reference temperature.

13.2.1 The convention of the notation shall be obeyed to arrive at the correct emf: that is, the symbols on the brackets indicate the progression of emf as if they were measured at temperatures from the lower to the upper symbol.

13.3 To determine the emf value of a thermocouple (E_{tc}) with its measurement junction at T_t , and referenced to 0°C (T_i), made by combining thermoelements (samples of which were tested according to this method):

TABLE 1 List of Possible Uncertainty in emf Values Estimated for a KP Thermoelement^A

Error Source	Estimated Uncertainty (μV)
Reference Thermoelement Certified Value	30
Reference Thermoelement Inhomogeneity	5
Test Thermoelement Inhomogeneity	15
Test Thermoelement Drift During Test	10
Effect of Off-Target Test Temperature	0
Improper Immersion in Test Temperature Medium	5
Non-isothermal or Contaminated Junctions	5
Switches	5
Emf Indicator	5
Poor Thermal Coupling to the Reference Temperature	5
Extreme Difference in Cross Section Between Test and Reference Thermoelements	5
Electromagnetic Interference	10
Preferential Oxidation Atmosphere in Test Media	5
Interpolation, Numerical, or Polarity Errors	large variation

^A These values are typical uncertainties for new thermocouple materials and the are opinions of the Committee members. They depend upon the actual equipment used.

$$E_{tc} = E_{xp1} - E_{xp2} \quad (4)$$

where:

- E_{xp1} = the emf of the more positive thermoelement (relative to Pt-67, from T_i to T_t), and
- E_{xp2} = the emf of the less positive thermoelement (relative to Pt-67, from T_i to T_t).

13.3.1 *Example*—To determine the emf of a Type K thermocouple with a test temperature of 800°C and a reference junction at 0°C:

- (1) The emf of a KP thermoelement versus Pt-67 at 800°C = +26.220 mV
- (2) The emf of a KN thermoelement versus Pt-67 at 800°C = -7.052 mV
- (3) The emf of the thermocouple at 800°C = +33.272 mV

13.4 Upon request, a certificate of conformance shall be prepared for the customer. The certificate shall state that the material has been tested in conformance with this ASTM test method and it shall include at least the following: the supplier's

name, address, and telephone or fax number; the unambiguous identification of the material represented by the data; the date of test; the emf data of the test samples at each test temperature requested; an indication of traceability of the emf of the reference thermoelements to NIST; and the temperature scale that was used. The test data and certifications shall remain in the supplier's files for a period of at least seven years.

14. Precision and Bias

14.1 The degree of uncertainty of test results depends upon the extent to which sources of error are controlled. The expected errors attributable to equipment and procedure are given in **Table 1** and estimated for a KP thermoelement. Refer to **13.4** concerning how to acquire a statement of uncertainty. Refer to **7.5.2** for calculating uncertainties in the reference thermoelement between reported temperatures.

15. Keywords

15.1 calibration; emf; ice point; junction; Pt-67; reference temperature; Seebeck coefficient; temperature; thermoelectric emf; thermoelement; thermocouple

APPENDIX

(Nonmandatory Information)

X1. USING A DATA ACQUISITION SYSTEM AS AN EMF RECORDING DEVICE

X1.1 For accuracy and efficiency, the preferred instrumentation for thermoelectric emf testing is a microprocessor-based digital data acquisition system. Such a system would collect data faster than the observe-and-record method. Thus, the data taken from a number of specimens with a data acquisition system would be obtained before the temperature of the junctions would change significantly. This type of measuring

system usually permits direct input to a computer, which eliminates manual interpolation errors and facilitates subsequent computations and report generation. With a suitable display, a data acquisition system would help to indicate when thermal equilibrium of the test assembly is achieved. Some level of automation can also be achieved with a microprocessor-based digital data acquisition system.

X1.2 With electrically isolated inputs at the emf instrumentation, more than one set of thermoelements can be tested over the same period.

NOTE X1.1—Two-pole relay scanners associated with digital data acquisition systems are suitable because they isolate the inputs from each other. Moreover, low-thermal relays, designed for low emf applications are preferred because they drift less than solid-state scanners and tend not introduce extraneous thermal emf.

X1.3 Besides accommodating multiple specimens, the data acquisition system should have the capability of accepting additional inputs, for example:

X1.3.1 A sensor to monitor the test temperature,

X1.3.2 A sensor to monitor the reference temperature,

X1.3.3 A short to represent zero input (for monitoring drift), and

X1.3.4 A reference source of voltage (for monitoring the calibration of the emf indicator).

X1.4 The output of the data acquisition system should include the date and time of the test, the identification of samples, and any other pertinent information that enhances credibility.

ASTM International takes no position respecting the validity of any patent rights asserted in connection with any item mentioned in this standard. Users of this standard are expressly advised that determination of the validity of any such patent rights, and the risk of infringement of such rights, are entirely their own responsibility.

This standard is subject to revision at any time by the responsible technical committee and must be reviewed every five years and if not revised, either reapproved or withdrawn. Your comments are invited either for revision of this standard or for additional standards and should be addressed to ASTM International Headquarters. Your comments will receive careful consideration at a meeting of the responsible technical committee, which you may attend. If you feel that your comments have not received a fair hearing you should make your views known to the ASTM Committee on Standards, at the address shown below.

This standard is copyrighted by ASTM International, 100 Barr Harbor Drive, PO Box C700, West Conshohocken, PA 19428-2959, United States. Individual reprints (single or multiple copies) of this standard may be obtained by contacting ASTM at the above address or at 610-832-9585 (phone), 610-832-9555 (fax), or service@astm.org (e-mail); or through the ASTM website (www.astm.org). Permission rights to photocopy the standard may also be secured from the Copyright Clearance Center, 222 Rosewood Drive, Danvers, MA 01923, Tel: (978) 646-2600; <http://www.copyright.com/>