



Standard Practice for Fabrication of the Neutron Radiographic Beam Purity Indicators¹

This standard is issued under the fixed designation E2003; the number immediately following the designation indicates the year of original adoption or, in the case of revision, the year of last revision. A number in parentheses indicates the year of last reapproval. A superscript epsilon (ϵ) indicates an editorial change since the last revision or reapproval.

1. Scope

1.1 This practice covers the material and fabrication of a Beam Purity Indicator (BPI), which can be used to determine the relative quality of radiographic images produced by direct, thermal neutron radiographic examination.

1.2 The values stated in SI units are regarded to be standard.

1.3 *This standard does not purport to address the safety concerns, if any, associated with its use. It is the responsibility of the user of this standard to establish appropriate safety and health practices and determine the applicability of regulatory limitations prior to use.*

2. Referenced Documents

2.1 *ASTM Standards:*²

[E543 Specification for Agencies Performing Nondestructive Testing](#)

[E545 Test Method for Determining Image Quality in Direct Thermal Neutron Radiographic Examination](#)

[E748 Practices for Thermal Neutron Radiography of Materials](#)

[E1316 Terminology for Nondestructive Examinations](#)

3. Terminology

3.1 *Definitions*— For definitions of terms used in this practice, see Terminology [E1316](#), Section H.

4. Summary of Practice

4.1 The BPI is used for quantitative determination of thermal neutron radiographic quality. It consists of a polytetrafluoroethylene block containing two boron nitride disks, two lead disks and two cadmium wires. A key feature of the device is the ability to make visual analysis of its image for subjective

¹ This practice is under the jurisdiction of ASTM Committee [E07](#) on Nondestructive Testing and is the direct responsibility of Subcommittee [E07.05](#) on Radiology (Neutron) Method.

Current edition approved Oct. 1, 2014. Published November 2014. Originally approved in 1998. Last previous edition approved in 2010 as E2003 - 10. DOI: 10.1520/E2003-10R14.

² For referenced ASTM standards, visit the ASTM website, www.astm.org, or contact ASTM Customer Service at service@astm.org. For *Annual Book of ASTM Standards* volume information, refer to the standard's Document Summary page on the ASTM website.

quality information. Densitometric measurements of the image of the device permit quantitative determination of radiographic contrast, low-energy photon contribution, pair production contribution, image unsharpness, and information regarding film and processing quality.

4.2 Neutron radiography practices are discussed in Practice [E748](#).

5. Significance and Use

5.1 The BPI is designed to yield quantitative information concerning neutron beam and image system parameters that contribute to film exposure and, thereby, affect overall image quality. For proper measurements of film exposure due to the neutron beam constituents, the BPI must be fabricated in accordance with this practice.

5.2 This practice shall be followed for the fabrication of all Beam Purity Indicators to be used with Method [E545](#) to determine image quality in direct thermal neutron radiography.

6. Basis of Application

6.1 *Qualification of Nondestructive Agencies*—If specified in the contractual agreement, NDT agencies shall be qualified and evaluated as described in Practice [E543](#). The applicable revision of Practice [E543](#) shall be specified in the contractual agreement.

6.2 *Procedures and Techniques*—The procedures and techniques to be utilized shall be as described in this practice unless otherwise specified. Specific techniques may be specified in the contractual agreement.

6.3 *Reporting Criteria/Acceptance Criteria*—Reporting criteria for the examination results shall be in accordance with Sections [9](#) and [10](#) unless otherwise specified. Acceptance criteria, for example, for reference radiographs, shall be specified in the contractual agreement.

6.4 *Reexamination of Repaired/Reworked Items*—Reexamination of repaired/reworked items is not addressed in this practice and, if required, shall be specified in the contractual agreement.

7. Beam Purity Indicator (BPI)

7.1 The BPI shall be constructed of polytetrafluoroethylene, cadmium, lead, and boron nitride.

7.2 The construction and dimensions shall be as shown in Fig. 1.

7.3 The BPI may be encased in a frame for easy mounting, but shall not be enclosed in a dust cover nor shall any material cover either side of the BPI face.

7.4 Cadmium and lead shall be at least 99.9 % pure elemental material.

7.5 Boron nitride shall be hot-pressed, minimum 40 % elemental boron.

7.6 The polytetrafluoroethylene block tolerances shall be $\pm 10\%$.

7.7 The tolerances for the holes and the grooves shall be such that the disks and the wires do not fall out during use.

8. Fabrication

8.1 Individual Components:

8.1.1 Form the polytetrafluoroethylene base by milling an 8-mm thick sheet of the material into a 25-mm square.

8.1.2 Drill a 16 ± 1 -mm hole in the center of the unit.

8.1.3 Mill two 4-mm diameter by 2-mm deep holes centered 4-mm from adjacent corners on one face of the unit.

8.1.4 Cut two lengths of 0.7 ± 0.1 -mm diameter cadmium wire, each 12-mm long.

8.1.5 Mill a groove in the base between the holes milled in 8.1.3. The groove should be 0.04 mm deeper and 0.04 mm narrower than the diameter of the wire cut in 8.1.4, so the wire

will be flush and tight. The groove may extend to the outside edge of the unit (see Fig. 1).

8.1.6 Repeat the process on the opposite face, making certain that the holes are not stacked upon each other.

8.1.7 Prepare a 4-mm diameter rod of boron nitride (a lathe may be used).

8.1.8 Cut off two 2-mm thick disks from the rod machined in 8.1.7.

8.1.9 Prepare a 4-mm diameter rod of lead (a lathe may be used).

8.1.10 Cut off two 2-mm thick disks from the rod machined in 8.1.9.

8.2 Assembly:

8.2.1 Place the polytetrafluoroethylene block with the two holes and groove on the left side.

8.2.2 Insert a lead disk (as prepared in 8.1.9 and 8.1.10) in the upper hole.

8.2.3 Insert a boron nitride disk (as prepared in 8.1.7 and 8.1.8) in the lower hole.

8.2.4 Insert a cadmium wire piece (as prepared in 8.1.4) into the groove between the two disks, making certain the wire is flush, tight, and centered.

8.2.5 Turn the block over and orient it so that the groove and holes are on the left side. Repeat the steps specified in 8.2.1 through 8.2.4.

8.2.6 The final assembly shall conform to Fig. 1.

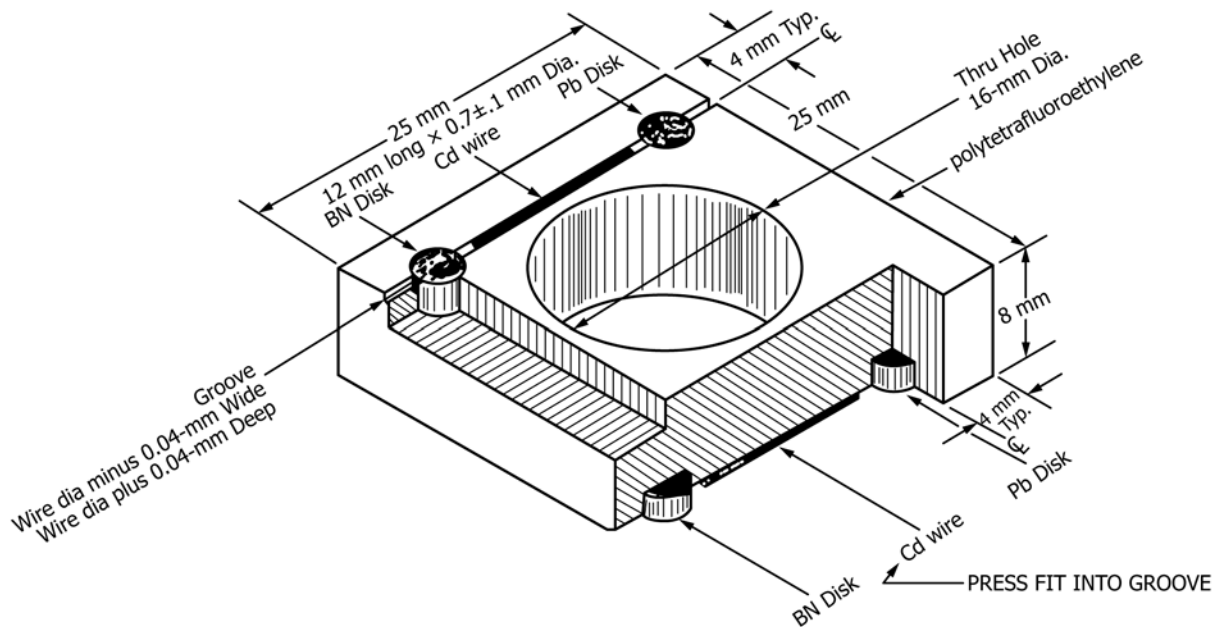

- Polytetrafluoroethylene
- Cadmium 99.9 % pure
- Lead 99.9 % pure
- BN-Boron nitride
- Hot-pressed, 40 % min elemental boron

NOTE 1—Pb and BN disks are 4-mm in diameter and 2-mm thick (minimum thickness).

FIG. 1 Beam Purity Indicator

9. Certification

9.1 Upon request of the purchaser by contract or purchase order, any fabricator of the BPI described in this practice shall provide materials certification. To verify correct assembly and functionality, a comparison thermal neutron radiograph of the assembled BPI and a reference BPI shall be provided.

9.2 The comparison thermal neutron radiograph of the assembled BPI along with a reference BPI shall show the following:

9.2.1 The disks and wires are properly placed and intact.

9.2.2 Using Method E545 (latest revision), calculate the values for thermal neutron, scattered neutron, gamma, and pair production content.

9.2.3 The values should be comparable to those of the reference BPI.

9.2.4 Assign a unique identification number to the acceptable unit and mark the BPI. The identification number shall be

such that it shall not interfere with any density readings used to calculate any exposure contributors (see Method E545, latest revision).

9.3 The comparison thermal neutron radiograph of the assembled BPI with the reference BPI shall meet quality level Category I specified in Method E545, latest revision.

9.4 Any BPI fabricated in accordance with Method E545 from 1981 through 1991 is acceptable as a reference BPI (unless there is known to be a disqualifying deficiency).

10. Records

10.1 Complete records of the fabrication details shall be maintained by the manufacturing facility for three years or as specified in the basis of purchase.

11. Keywords

11.1 beam purity indicator; direct method; image quality indicator; neutron radiography; sensitivity indicator

ASTM International takes no position respecting the validity of any patent rights asserted in connection with any item mentioned in this standard. Users of this standard are expressly advised that determination of the validity of any such patent rights, and the risk of infringement of such rights, are entirely their own responsibility.

This standard is subject to revision at any time by the responsible technical committee and must be reviewed every five years and if not revised, either reapproved or withdrawn. Your comments are invited either for revision of this standard or for additional standards and should be addressed to ASTM International Headquarters. Your comments will receive careful consideration at a meeting of the responsible technical committee, which you may attend. If you feel that your comments have not received a fair hearing you should make your views known to the ASTM Committee on Standards, at the address shown below.

This standard is copyrighted by ASTM International, 100 Barr Harbor Drive, PO Box C700, West Conshohocken, PA 19428-2959, United States. Individual reprints (single or multiple copies) of this standard may be obtained by contacting ASTM at the above address or at 610-832-9585 (phone), 610-832-9555 (fax), or service@astm.org (e-mail); or through the ASTM website (www.astm.org). Permission rights to photocopy the standard may also be secured from the Copyright Clearance Center, 222 Rosewood Drive, Danvers, MA 01923, Tel: (978) 646-2600; <http://www.copyright.com/>