



Standard Practice for Ultrasonic Surface Testing Using Electromagnetic Acoustic Transducer (EMAT) Techniques¹

This standard is issued under the fixed designation E1962; the number immediately following the designation indicates the year of original adoption or, in the case of revision, the year of last revision. A number in parentheses indicates the year of last reapproval. A superscript epsilon (ϵ) indicates an editorial change since the last revision or reapproval.

1. Scope*

1.1 This practice covers guidelines for utilizing EMAT techniques for detecting material discontinuities that are primarily open to the surface (for example, cracks, seams, laps, cold shuts, laminations, through leaks, lack of fusion). This technique can also be sensitive to flaws and discontinuities that are not surface-breaking, provided their proximity to the surface is less than or equal to the Rayleigh wave length.

1.2 This practice covers procedures for the non-contact coupling of surface waves into a material via electromagnetic fields.

1.3 The procedures of this practice are applicable to any material in which acoustic waves can be introduced electromagnetically. This includes any material that is either electrically conductive or ferromagnetic, or both.

1.4 This practice is intended to provide examination capabilities for in-process, final, and maintenance applications.

1.5 This practice does not provide standards for the evaluation of derived indications. Interpretation, classification, and ultimate evaluation of indications, albeit necessary, are beyond the scope of this practice. Separate specifications or agreement will be necessary to define the type, size, location, and direction of indications considered acceptable or non-acceptable.

1.6 The values stated in inch-pound units are to be regarded as the standards. The SI units given in parentheses are for information only.

1.7 *This standard does not purport to address all of the safety concerns, if any, associated with its use. It is the responsibility of the user of this standard to establish appropriate safety and health practices and determine the applicability of regulatory limitations prior to use.*

¹ This practice is under the jurisdiction of ASTM Committee E07 on Nondestructive Testing and is the direct responsibility of Subcommittee E07.06 on Ultrasonic Method.

Current edition approved Oct. 1, 2014. Published October 2014. Originally approved in 1998. Last previous edition approved in 2009 as E1962 - 09. DOI: 10.1520/E1962-14.

2. Referenced Documents

2.1 ASTM Standards:²

E543 Specification for Agencies Performing Nondestructive Testing

E587 Practice for Ultrasonic Angle-Beam Contact Testing

E1316 Terminology for Nondestructive Examinations

E1774 Guide for Electromagnetic Acoustic Transducers (EMATs)

E1816 Practice for Ultrasonic Testing Using Electromagnetic Acoustic Transducer (EMAT) Techniques

2.2 ANSI/ASNT Standards:

Recommended Practice SNT-TC-1A Personnel Qualification and Certification in Nondestructive Testing³

ANSI/ASNT CP-189 Standard for Qualification and Certification of Nondestructive Testing Personnel³

2.3 Military Standard:

MIL-STD-410 Nondestructive Testing Personnel Qualification and Certification⁴

3. Terminology

3.1 Definitions:

3.1.1 Additional related terminology is defined in Terminology E1316.

3.2 Definitions of Terms Specific to This Standard:

3.2.1 *electromagnetic acoustic transducer (EMAT)*—an electromagnetic device for converting electrical energy into acoustical energy in the presence of a magnetic field.

3.2.2 *Lorentz forces*—applied to electric currents when placed in a magnetic field. Lorentz forces are perpendicular to both the direction of the magnetic field and the current direction.

3.2.3 *magnetostrictive forces*—forces arising from magnetic domain wall movements within a magnetic material during

² For referenced ASTM standards, visit the ASTM website, www.astm.org, or contact ASTM Customer Service at service@astm.org. For *Annual Book of ASTM Standards* volume information, refer to the standard's Document Summary page on the ASTM website.

³ Available from American National Standards Institute (ANSI), 25 W. 43rd St., 4th Floor, New York, NY 10036, <http://www.ansi.org>.

⁴ Available from U.S. Government Printing Office Superintendent of Documents, 732 N. Capitol St., NW, Mail Stop: SDE, Washington, DC 20401.

*A Summary of Changes section appears at the end of this standard

magnetization, where magnetostrictive materials will undergo a strain in the presence of a magnetic field.

3.2.4 *meander coil*—an EMAT coil consisting of periodic, winding, non-intersecting, and usually evenly-spaced conductors.

4. Summary of Practice

4.1 The techniques outlined in this practice address the electromagnetic generation of Rayleigh acoustic wave modes for sensitivity to surface or near-surface flaws or discontinuities. Flaws are detected by reflection or attenuation of acoustic waves from interactions at discontinuity interfaces.

4.2 Fig. 1 shows one typical EMAT setup for the generation of Rayleigh waves. An external magnetic induction B_0 parallel to the surface is applicable on ferromagnetic material. Other applications where B_0 is perpendicular to the surface can also be used if the coil design is appropriate. The magnetic field may be generated by a permanent magnet, a pulsed magnet, or a DC electromagnet. A meander RF coil is oriented in the plane of and near the surface of the object to be tested. The magnetic field lines are tangential to the coil and perpendicular to the conductor. The coil is excited by an RF toneburst pulse produced by a specialized EMAT pulser. A surface current is induced in the test sample by transformer action. The surface current interacts with the external magnetic field by means of the Lorentz force. The time varying magnetic field will also interact with the ferromagnetic material to generate vibrations via magnetostriction. This disturbance is transferred to the lattice of the solid and is thus the ultrasonic source responsible for producing the surface acoustic waves. As shown in Fig. 1, an ordinary meander coil produces bidirectional waves. In practice, specially designed meander coils can be designed to produce unidirectional waves.

4.3 Fig. 2 illustrates a typical meander coil for generation of surface waves. The following relationship must be valid for Rayleigh wave generation with a meander coil:

$$V_R = 2Df \tag{1}$$

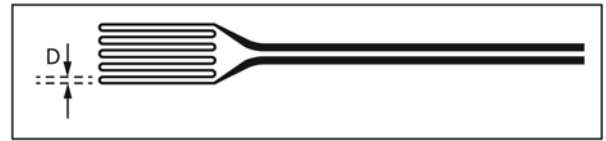

FIG. 2 Typical EMAT Meander Coil for Generation of Surface Waves

where:

- V_R = Rayleigh wave velocity,
- D = separation of adjacent conductors, and
- f = frequency.

4.4 Surface flaws or discontinuities lead to reflection or attenuation of the surface waves. Either pulse-echo or pitch-catch modes can be used. Upon approaching the receiver EMAT, the reflected or attenuated ultrasonic waves produce oscillations within the conductor in the presence of the magnetic field and thus induce a voltage in the receiver coil (similar to an electric generator) allowing detection.

5. Significance and Use

5.1 EMAT techniques show benefits and advantages over conventional piezoelectric ultrasonic techniques in special applications where flexibility in the type of wave mode generation and where no fluid coupling is desired. EMATs are highly efficient in the generation of surface waves.

5.2 Since EMATs are highly efficient in the generation of surface waves, and since acoustic techniques utilizing surface waves are proven effective for detecting surface and near-surface discontinuities, they should be considered for any applications where conventional penetrant testing and magnetic particle NDT techniques are effective but undesirable.

5.3 Since EMAT techniques are non-contacting, they should be considered for ultrasonic testing where applications involve automation, high-speed examinations, moving objects, applications in remote or hazardous locations, applications to objects at elevated temperatures, or objects with rough surfaces.

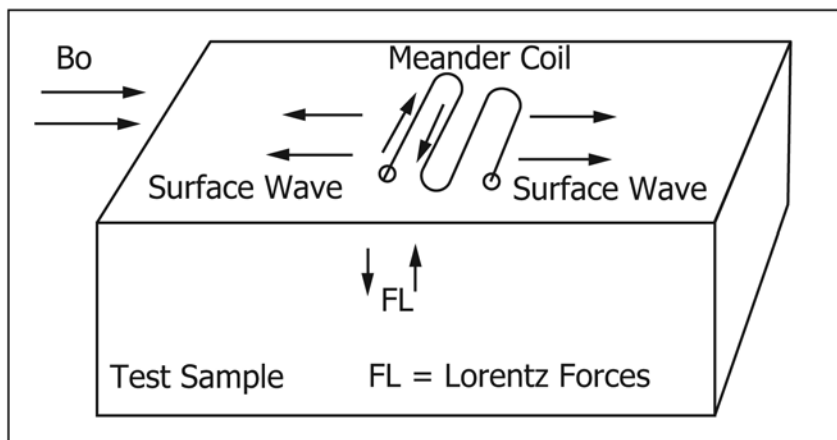

FIG. 1 Typical EMAT Configuration for Rayleigh Wave Generation

5.4 The purpose of this practice is to promote the EMAT technique of the ultrasonic method as a viable alternative to conventional PT and MPT methods for detecting the presence of surface and near-surface material discontinuities.

5.5 The use of EMATs and the selection of appropriate operating parameters presuppose a knowledge of the geometry of the component; the probable location, size, orientation, and reflectivity of the expected flaws; the allowable range of EMAT lift-off; and the laws of physics governing the propagation of ultrasonic waves. This procedure pertains to a specific EMAT surface inspection application.

6. Basis of Application

6.1 The following items are subject to contractual agreement between the parties using or referencing the standard:

6.1.1 *Personnel Qualification*

6.1.1.1 *If specified in the contractual agreement*, personnel performing examination to this practice shall be qualified in accordance with a nationally or internationally recognized NDT personnel qualification practice or standard such as ANSI/ASNT-CP-189, SNT-TC-1A, MIL STD-410, or a similar document and certified by the employer or certifying agency, as applicable. The practice or standard used and its applicable revision shall be identified in the contractual agreement between the using parties.

6.1.2 *Qualification of Nondestructive Agencies*—If specified in the contractual agreement, NDT agencies shall be qualified and evaluated as described in Practice E543. The applicable edition of Practice E543 shall be specified in the contractual agreement.

6.1.3 *Procedures and Techniques*—The procedures and techniques to be utilized shall be as specified in the contractual agreement.

6.1.4 *Surface Preparation*—The pre-examination surface preparation criteria shall be in accordance with 10.2.2 unless otherwise specified.

6.1.5 *Timing and Extent of Examination*—Shall be specified in the contractual agreement

6.1.6 *Reporting Criteria/Acceptance Criteria*—Reporting criteria for the examination results shall be in accordance with Section 12 unless otherwise specified. Acceptance criteria shall be specified in the contractual agreement.

6.1.7 *Reexamination of Repaired/Re-Worked Items*—Reexamination of repaired/re-worked items is not addressed in this practice and, if required, shall be specified in the contractual agreement.

7. Techniques

7.1 This practice describes three separate techniques for EMAT surface wave examination. The first involves pulse-echo or pitch-catch techniques for the detection of reflected surface waves. The second technique involves a pitch-catch method sensitive to the attenuation of surface waves. The third technique involves surface wave diffraction with focused meander coils.

7.2 *Pulse-Echo or Pitch-Catch Reflected Surface Wave Technique*—These techniques are analogous to conventional ultrasonic techniques. The techniques use either one (pulse-

echo) or two (pitch-catch) EMAT sensors and rely upon the reception of reflected surface waves from the flaw. The advantage of these techniques is simplicity. One disadvantage is the difficulty in detecting all flaw orientations without elaborate scanning routines. Also, when these techniques are used for weld applications, a problem arises in that the root and crown of the weld can produce reflections that are prominent enough to interfere with and even obscure flaw signals. When such interferences are apparent, it is recommended that one of the other two techniques described herein be utilized to avoid these problems.

7.3 *Pitch-Catch Attenuation Technique*—The attenuation technique is most effectively applied using the arrangement of sensors illustrated in Fig. 3. The technique indicates the presence of a flaw by noting attenuation of the UT signal. The sensors use small permanent magnets to generate narrow surface wave beams that cross at right angles. The preferred technique requires two channels of EMAT instrumentation although it may be modified for one-channel operation. To implement one-channel operation, the distance between one transmitter receiver pair is increased slightly to displace the two received signals in time. The transmitter coils are then wired in series and the receiver coils are wired in series. This arrangement allows both pairs of EMAT coils to be used with one channel of EMAT instrumentation. One advantage to the attenuation technique is sensitivity to all flaw orientations. Another advantage to using the attenuation technique is the ability to scan both sides of a weld simultaneously. It also scans large areas of the material in one scan. A disadvantage relates to the beam width, which must be narrow or focused in order to achieve a minimum of 6 dB of attenuation.

7.4 *Diffraction Technique*—The basis of the diffraction technique is illustrated in Fig. 4. Two collinear focused EMATs (transmitter and receiver) or one pulse-echo EMAT are positioned at an angle (the diffraction angle) with respect to the normal to the weld centerline. The weld root and crown act as a specular reflector whose signals are reflected away from the EMAT receiver. The flaw is, however, detected over a wide angular range by means of diffraction. Depending upon the size of the flaw relative to the ultrasonic wavelength, it acts as either a point diffractor or a series of point diffractors. A natural

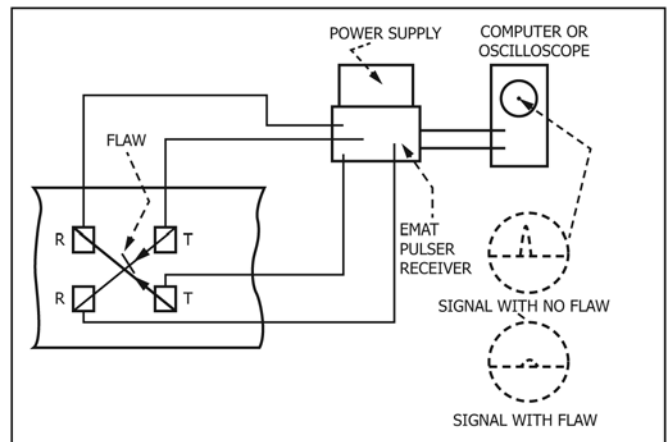

FIG. 3 Attenuation Technique

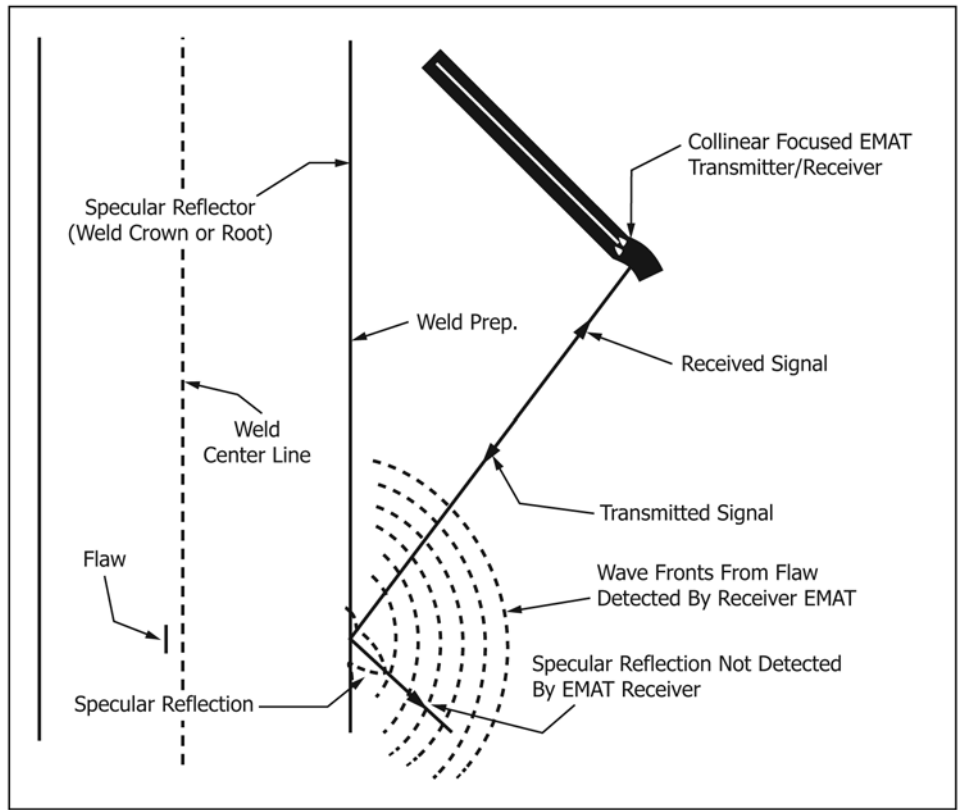

FIG. 4 The Diffraction Technique

flaw such as a fatigue crack has a series of facets and branches that act as point diffractors. Therefore, it is typically possible to detect the presence of a natural flaw several inches long with this technique. Surface waves can be focused to a region approximating a point focus (a region approaching a wavelength as a limit). It is frequently advantageous to have a reasonable focal depth to increase the area covered with each linear scan. For many welds, it is possible to scan one half of the weld crown from each side of the weld. A single EMAT sensor is sensitive to all orientations except possibly a crack parallel to the incident beam. Therefore, two sensors with positive and negative diffraction angles will be sensitive to all flaw orientations.

8. Apparatus

8.1 The apparatus may be considered to consist of the EMAT sensor and the EMAT instrumentation. The sensor consists of an RF coil and a source of magnetic field. The instrumentation consists of a tone burst pulser/receiver, a data acquisition system or display device such as an oscilloscope, an impedance matching network, a preamplifier (preferred), and a well shielded cable from the pulser/receiver to the sensor.

8.2 Coil Design:

8.2.1 A meander coil is used to produce surface waves. Coil design and conductor spacing required to produce a given frequency has been discussed in 4.3. The coil may be focused or nonfocused depending upon the technique being used and the desired resolution and sensitivity. Fig. 5 gives an example of typical design parameters for a focused coil, similar to that

used for the diffraction technique. Many EMAT coils are flexible printed circuits produced by photoetching on a polyamide substrate. The surface of the coil can be backed with a thin layer of foam and covered with a thin (0.001 to 0.005 in. (0.025 to 0.127 mm)) wearplate of high molecular weight polyethylene or titanium. The purpose of the wearplate is to maintain a constant liftoff for the EMAT coil. The wearplate should be pliable and conform to irregular or curved surfaces. The polyamide substrate usually has a thickness of 0.001 or 0.002 in. (0.025 or 0.051 mm). For “as welded” crowns, the selected frequency for any of the techniques should be no greater than necessary in order to minimize the response to surface roughness from the weld.

8.2.2 A typical operating frequency for the diffraction technique is 1 MHz. A typical frequency used for the attenuation technique is 2 MHz. A coil that might be used for the attenuation technique is shown in Fig. 6. The extensions to the polyamide substrate fasten to the magnet keeper in the mechanical fixture.

8.3 *Coil Excitation*—A high-power, specialized RF generator is necessary to provide excitation to the coil in the form of a toneburst of several cycles.

8.4 *Magnetization*—In room temperature applications (nominally less than 180°F [82°C]) neodymium iron boron permanent magnets can be used for all EMAT surface wave techniques. High temperature applications may require the use of more complicated magnetization techniques, such as electromagnetics or specialized permanent magnets designed for

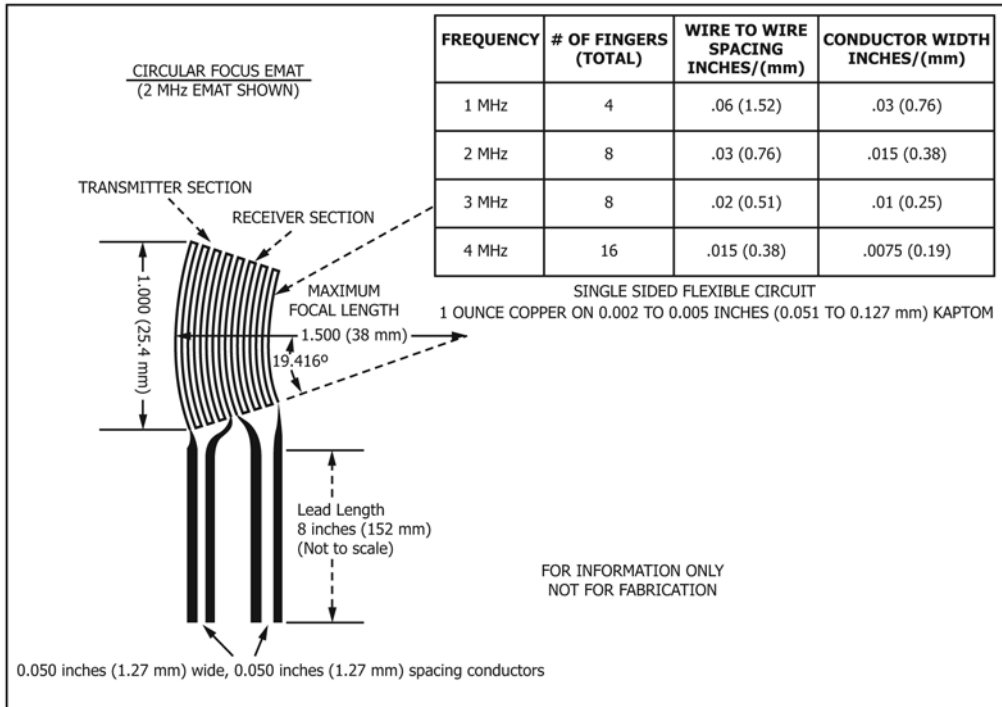

FIG. 5 Design Parameters for Typical Focused EMAT Coil

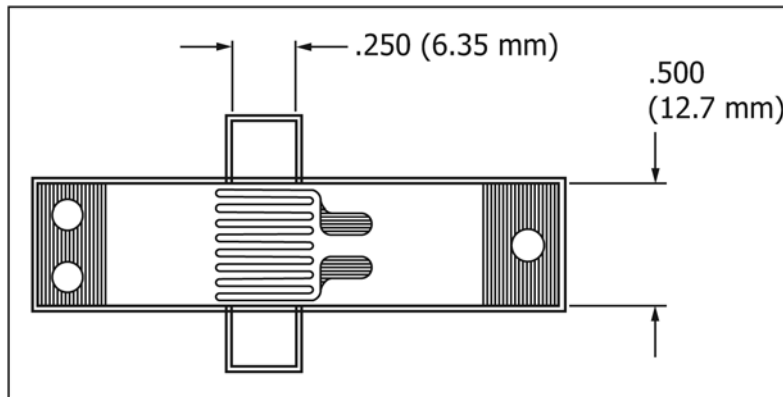

FIG. 6 A Typical EMAT coil Used for the Attenuation Technique

operation in high temperatures. Typical dimensions of the magnets and the direction of the magnetic induction B is shown in Fig. 7 for the attenuation and diffraction techniques. The direction of B is perpendicular to both the RF coil and the

examination surface. The permanent magnets allow compact sensors to be used for field applications, however, pulsed or DC electromagnets could also be used, if required. The field direction could be either parallel or perpendicular to the

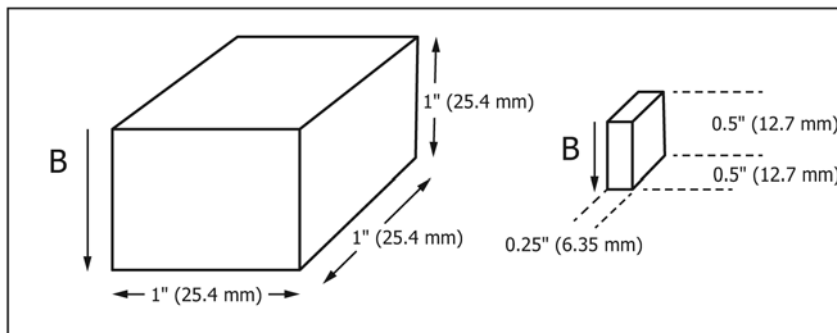

FIG. 7 Permanent Magnets

conductor examination surface for ferromagnetic materials or perpendicular to the examination surface for nonferromagnetic conductors.

8.5 Instrumentation—The signal processing and data acquisition electronics should consist of a receiver section to provide for adjustable gain and filtering for the EMAT signals. Conventional ultrasonic instruments can be used for this purpose. The user has several options to capture and analyze the EMAT signals. A personal computer housing any of several commercially available analog-to-digital converter boards with associated dedicated ultrasonics software provides for an effective configuration. However, as with conventional ultrasonics, configurations as simple as analog output to oscilloscope can provide for acceptable results. In either case, pulser/receiver synchronization circuitry will be necessary to provide adequate triggering for signal acquisition.

8.6 Reference Standard:

8.6.1 A reference standard for verification of the system standardization should be prepared from a component of the same material, thickness, surface finish, and nominal heat treatment as the material to be examined. The material should be free of discontinuities or other abnormal conditions other than those reference reflectors exemplifying the necessary sensitivity. Flaw dimensions of length, depth, and width, must be consistent with the acceptance criteria.

8.6.2 Since EMATs are normally bidirectional, edge reflections can obscure the desired reference reflection. Therefore, the position of all reference reflectors and the geometry of reference standards must be designed to avoid the interference of edge reflections and reference reflections.

8.6.3 Reference Standards for Surface Examination of Weldments:

8.6.3.1 A reference standard for verification of the system standardization should be prepared from a length of weldment of the same material, welding magnetic properties, thickness, surface finish, and nominal heat treatments as the material to be examined. The weldment must be free of discontinuities or other abnormal conditions that could cause interference with detection of the reference reflectors. The reference reflectors should be selected to insure uniform coverage of the weld at the sensitivity levels and orientations prescribed. The reference reflectors most commonly used will consist of electric discharge machine (EDM) notches or mechanically machined notches.

8.6.3.2 Reference reflectors may be placed in the weld seam, in the base material heat affected zone of the weld, or in the material parallel to the weld seam, as specified in the weld acceptance criteria.

8.6.3.3 The machined notch orientation and dimensions of length, depth, and width must be decided upon by the using party or parties and should be consistent with the weld acceptance criteria.

8.6.3.4 The notch depth should be measured from the adjacent surface to its maximum and minimum penetration. Measurements may be made by optical, replicating, mechanical, or other techniques. Notch depth is commonly specified as a percent of nominal thickness.

8.6.3.5 The position of the reference reflectors and the geometry of the reference standard must be designed to avoid the interference of edge reflections with reference reflections.

9. Standardization

9.1 Since EMATs are not generally commercially available, as are conventional piezoelectric search units and often require a specialized design, it is the responsibility of the designer to ensure that the EMAT configurations demonstrate the specific sensitivity and frequency characteristics prior to their initial use. Thereafter, it is adequate to standardize the EMAT system as a unit with regard to response from reference standards alone.

9.2 Prior to examination, it is recommended that the EMAT system be standardized by means of ASTM or other reference blocks, as specified in the contractual specification.

9.3 Reference standards should have ultrasonic characteristics similar to the material being tested and, more specifically, should be selected as described in Section 8 for the specific applications.

9.4 As in conventional ultrasonic application, attenuation correction should be completed if the amplitude of a reference reflector in the reference standard does not match that of the test sample.

9.5 Reference standards should be rechecked following system or operator changes to maintain standardization.

9.6 During operation, the system should be standardized every four hours of operation, or as contractually agreed upon, to insure that the EMAT system accuracy is being maintained. The system should be adjusted anytime that a signal varies by 10 % or more from that established initially from the reference standard.

9.7 If the EMATs are being operated in a scan mode of operation, it should be verified that the scan rates are conducive with electronic digitizing rates to ensure ultrasonic resolution adequate to the specific contract.

9.8 Unless otherwise specified, the EMAT system should always provide for an A-scan display option.

9.9 Specific standardization should be generated for specific applications. Generic procedures for surface wave examinations are outlined as follows:

9.10 Surface Wave Examination:

9.10.1 Reference Block Selection—The reference blocks should have the size, orientation and type of reference reflector specified in the contractual agreement. Equipment adjustments shall be made to produce clearly identifiable indications to verify the test sensitivity.

9.10.2 If accurate locations of reflectors are desired, standardization should follow the procedures outlined in Practice **E587** for surface waves.

10. Procedure

10.1 Pulse-Echo or Pitch-Catch Reflected Surface Wave Technique:

10.1.1 The procedure outlined herein describes an EMAT technique for the application of detecting surface discontinuities in components via pulse-echo or pitch-catch of reflected waveforms. While it is not purported to be the only applicable technique, it does describe a field-tested, proven methodology.

10.1.2 All surfaces of the components should be relatively free of scale, dirt, burrs and slag, splatter, or other conditions that could interfere with the examination results or damage the EMAT probe.

10.1.3 To examine the surface of a weld or base material, the operator places the EMAT coil on the object to be examined. A triggering pulse is sent to the EMAT coil pulser and simultaneously to the digitizing board if used. A tone burst pulse is generated in the transmit EMAT coil which, in the presence of the applied magnetic field, launches an ultrasonic wave. The magnetic induction can be supplied by a pulsed magnet, a permanent magnet, or a DC electromagnet.

10.1.4 The Rayleigh wave then traverses across the surface of the test component and is reflected by the presence of any surface breaking discontinuity. The reflected wave is then detected by the receiver EMAT coil, either by the same coil in a pulse-echo configuration, or a separate coil in a pitch-catch configuration.

10.1.5 The signal voltage from the receiver EMAT coil is amplified by a low-noise preamplifier and sent to the receiver section in the signal processing electronics, where it is further amplified, filtered, and sent to the waveform digitizer board. The detection of a discontinuity is indicated by the presence of a reflector in a digitized signal. The process is repeated for scan mode at fixed time intervals, and discontinuity presence is indicated by tracking the reflected signal amplitude and time of flight.

10.1.6 Periodically check the examination sensitivity of the equipment by scanning the reference standard. Make these checks prior to any examination, prior to equipment shutdown after examination, and at least every 4 h during continuous equipment operation. Adjust the equipment anytime that a signal varies in sensitivity by 10 % or more from that established initially from the reference standard.

10.2 *Pitch-Catch Attenuation Technique:*

10.2.1 The procedure outlined herein describes an EMAT technique for the application of detecting surface breaking discontinuities in components via a pitch-catch attenuation technique. While it is not purported to be the only applicable technique, it does describe a field-tested proven methodology.

10.2.2 All surfaces of the components should be relatively free of scale, dirt, burrs, slag, spatter, or other conditions that could interfere with the examination results or damage the EMAT probe.

10.2.3 To examine the surface of a weld or base material, the operator places the EMAT probe head on the object to be examined. If a weld is to be examined, the probe straddles the weld crown with two EMATs on one side of the weld and two EMATs on the other side of the weld. A triggering pulse is sent to the EMAT pulser and to the digitizer board. A tone burst pulse is generated in the transmit EMAT coil, which in the presence of the applied magnetic field, launches an ultrasonic

wave. The magnetic induction can be supplied by a pulsed magnet, a permanent magnet, or a DC electromagnet.

10.2.4 The Rayleigh wave from one of a pair of transmitters then traverses across the surface of the test component and is attenuated by the presence of any surface breaking discontinuity. The transmitted wave is then detected by the receiver EMAT coil. A similar sequence of events occurs for the other transmitter/receiver pair of EMAT coils which are orthogonal to the first pair.

10.2.5 The signal voltage from the receiver EMAT coil is amplified by a low-noise preamplifier and sent to the receiver section in the signal processing electronics, where it is further amplified, filtered, and sent to the waveform digitizer board. The detection of a discontinuity is indicated by the loss of signal amplitude in the digitized signal. As indicated in 7.2, the EMAT instrumentation can be either two channel or one channel.

10.2.6 Periodically check the examination sensitivity of the equipment by scanning the reference standard. Make these checks prior to any examination, prior to equipment shutdown after examination, and at least every four hours during continuous equipment operation. Adjust the equipment anytime that a signal varies in sensitivity by 10 % or more from that established initially from the reference standard.

10.2.7 It is assumed that reference reflectors, coil size, and so forth will be chosen to provide an attenuation of the signal amplitude of at least 6 dB if the flaws are to be detected visually. If a gated alarm device is used, the requirements are less stringent. Just as for the case of piezoelectric ultrasonics, attenuation is very dependent upon the surface roughness of a component. With EMATs, variations in liftoff can lead to false indications. There are, however, no variations in signal level with coupling as with piezoelectric ultrasonic techniques based upon attenuation if uniform lift-off is maintained for all sensors during the examination.

10.3 *Diffraction Technique:*

10.3.1 The procedure outlined herein describes an EMAT technique for the application of detecting surface discontinuities in components via a diffraction technique. While it is not purported to be the only applicable technique, it does describe a field-tested proven methodology

10.3.2 All surfaces of the components should be relatively free of scale, dirt, burrs and slag, splatter, or other conditions that could interfere with the examinations results or damage the EMAT probe.

10.3.3 To examine the surface of a weld or base material, the operator places the EMAT coil on the object to be examined. In practice, the diffraction angle is found where the crown signal or root signal is not detected but rather reflected away as a specular reflector. This permits the weld to be linearly scanned, and all orientations of surface-breaking defects to be detected without detecting the reflected signal from the crown. A triggering pulse is sent to the EMAT pulser and the digitizer board. A tone burst pulse is generated in the transmit EMAT coil which, in the presence of the applied magnetic field, launches an ultrasonic wave. The magnetic induction can be supplied by a pulsed magnet, a permanent magnet, or a DC electromagnet.

10.3.4 The Rayleigh wave then traverses across the surface of the test component and is reflected by the presence of any surface breaking discontinuity. The reflected wave is then detected by the receiver EMAT coil, either by the same coil in a pulse-echo configuration or a separate coil in a pitch-catch configuration.

10.3.5 The signal voltage from the receiver EMAT coil is amplified by a low-noise preamplifier and sent to the receiver section in the signal processing electronics, where it is further amplified, filtered, and sent to the waveform digitizer board. The detection of a discontinuity is indicated by the presence of a reflector in a digitized signal.

10.3.6 Periodically check the examination sensitivity of the equipment by scanning the reference standard. Make these checks prior to any examination, prior to equipment shutdown, after examination, and at least every four hours during continuous equipment operation. Adjust the equipment anytime that a signal varies in sensitivity by 10 % or more from that established initially from the reference standard.

11. Interpretation of Results

11.1 Agreement should be reached between the users of this practice and personnel for whom the ultrasonic testing is being performed, as applicable, regarding the interpretation of results

of the examinations as well as how these results should be recorded. All indications that exceed or fall below the rejection level, as appropriate for the technique and as defined by the material specification or purchase order, shall be rejected.

12. Report

12.1 Record the following information at the time of the report and include it in the report:

12.1.1 *Examination Procedure:*

12.1.1.1 Instrumentation description;

12.1.1.2 Standardization blocks, dimensions, flaw descriptions, and material types;

12.1.2 Detailed description of the EMAT, including size, frequency, and type; and

12.1.3 Scanning method.

12.2 *Results:*

12.2.1 Indication locations;

12.2.2 Thickness measurements; and

12.2.3 Personnel data and certification level.

13. Keywords

13.1 electromagnetic acoustic transducer; EMAT; flaw detection; NDT of welds; nondestructive testing; Rayleigh; surface waves; ultrasonic testing

SUMMARY OF CHANGES

Committee E07 has identified the location of selected changes to this standard since the last issue (E1962–09) that may impact the use of this standard.

(1) In 3.2.2, removed the statement, “Lorentz forces are the forces responsible behind the principle of electric motors.”

(2) Under 3.2.3, added the following statement: “where magnetostrictive materials will undergo a strain in the presence of a magnetic field.”

(3) In 4.2, after the words “ B_0 parallel to the surface is applicable on ferromagnetic material,” added the following statement: “Other applications where the B_0 is perpendicular to the surface can also be used if the coil design is appropriate.”

(4) In 4.2, added “The time varying magnetic field will also interact with the ferromagnetic material to generate vibrations via magnetostriction.”

(5) In 5.1, after the words “wave mode generation,” added “and where no fluid coupling.”

(6) In 8.4, added the following: “In room temperature applications (nominally less than 180°F [82°C]) high temperature applications may require the use of more complicated magnetization techniques, such as electromagnetics or specialized permanent magnets designed for operation in high temperatures.”

(7) In 9.1, rewrote the first sentence to state: “Since EMATs are not generally as commercially available as are conventional piezoelectric search units and often require a specialized design.”

(8) At the end of 10.2.7, after the word “attenuation,” added the following: “if uniform lift-off is maintained for all sensors during the inspection.”

(9) In 10.3, added the following sentence: “In practice, the diffraction angle is found where the crown signal or root signal is not detected but rather reflected away as a specular reflector.”

(10) In 10.3.5, removed the sentence, “In practice, the diffraction angle is found where the crown signal or root signal is not detected but rather reflected away as a specular reflector.”

(11) Replaced “inspection” with “examination” and “inspect” with “examine” throughout the standard to reflect with E07 preferred usage of these terms per 1.2 in E1316 and Section A of E1316.

ASTM International takes no position respecting the validity of any patent rights asserted in connection with any item mentioned in this standard. Users of this standard are expressly advised that determination of the validity of any such patent rights, and the risk of infringement of such rights, are entirely their own responsibility.

This standard is subject to revision at any time by the responsible technical committee and must be reviewed every five years and if not revised, either reapproved or withdrawn. Your comments are invited either for revision of this standard or for additional standards and should be addressed to ASTM International Headquarters. Your comments will receive careful consideration at a meeting of the responsible technical committee, which you may attend. If you feel that your comments have not received a fair hearing you should make your views known to the ASTM Committee on Standards, at the address shown below.

This standard is copyrighted by ASTM International, 100 Barr Harbor Drive, PO Box C700, West Conshohocken, PA 19428-2959, United States. Individual reprints (single or multiple copies) of this standard may be obtained by contacting ASTM at the above address or at 610-832-9585 (phone), 610-832-9555 (fax), or service@astm.org (e-mail); or through the ASTM website (www.astm.org). Permission rights to photocopy the standard may also be secured from the Copyright Clearance Center, 222 Rosewood Drive, Danvers, MA 01923, Tel: (978) 646-2600; <http://www.copyright.com/>