



Standard Test Method for Measuring Paved Surface Frictional Properties Using the Dynamic Friction Tester¹

This standard is issued under the fixed designation E1911; the number immediately following the designation indicates the year of original adoption or, in the case of revision, the year of last revision. A number in parentheses indicates the year of last reappraisal. A superscript epsilon (ϵ) indicates an editorial change since the last revision or reappraisal.

^{ε1} NOTE—Note 2 was editorially corrected in July 2009.

1. Scope

1.1 This test method covers the procedure for measuring paved surface frictional properties as a function of speed using the Dynamic Friction Tester (DF-Tester).

1.2 The DF Tester consists of a horizontal spinning disk fitted with three spring loaded rubber sliders which contact the paved surface as the disk rotational speed decreases due to the friction generated between the sliders and the paved surface. A water supply unit delivers water to the paved surface being tested. The torque generated by the slider forces measured during the spin down is then used to calculate the friction as a function of speed.

1.3 The DF Tester can be used for laboratory investigations and in the field on actual paved surfaces.

1.4 The values stated in SI (metric) units are to be regarded as standard. The inch-pound equivalents are rationalized, rather than exact mathematical conversions.

1.5 *This standard does not purport to address all of the safety concerns, if any, associated with its use. It is the responsibility of the user of this standard to establish appropriate safety and health practices and determine the applicability of regulatory limitations prior to use.*

2. Referenced Documents

2.1 ASTM Standards:²

- E274 Test Method for Skid Resistance of Paved Surfaces Using a Full-Scale Tire
- E501 Specification for Rib Tire for Pavement Skid-Resistance Tests
- E867 Terminology Relating to Vehicle-Pavement Systems

¹ This test method is under the jurisdiction of Committee E17 on Vehicle - Pavement Systems and is the direct responsibility of Subcommittee E17.21 on Field Methods for Measuring Tire Pavement Friction.

Current edition approved July 1, 2009. Published July 2009. Originally approved in 1998. Last previous edition approved in 2009 as E1911 – 09. DOI: 10.1520/E1911-09AE01.

² For referenced ASTM standards, visit the ASTM website, www.astm.org, or contact ASTM Customer Service at service@astm.org. For *Annual Book of ASTM Standards* volume information, refer to the standard's Document Summary page on the ASTM website.

E1845 Practice for Calculating Pavement Macrotexture Mean Profile Depth

3. Terminology

3.1 *Definitions:* For Definitions of terms pertaining to this standard, see Terminology E867.

4. Summary of Test Method

4.1 This test method uses a disk that spins with its plane parallel to the test surface. Three rubber sliders are mounted on the lower surface of the disk. The disk work pavement is brought to the desired rotational velocity, corresponding to the maximum tangential velocity of the sliders. The DF Tester is capable of providing a maximum tangential velocity of 90 km/h (55 mph).

4.2 Water is introduced in front of the sliders and the disk is lowered to contact the test surface so that it bears the full velocity of the disk and model assembly.

4.3 The torque is monitored continuously as the disk rotational velocity reduces due to the friction between the sliders and the test surface.

4.4 The torque signal is reduced to a measurement of friction by converting the torque to the force on the sliders and dividing by the weight of the disk and motor assembly.

4.5 The friction at 20, 40, 60, and 80 km/h (12, 24, 36, and 48 mph) is recorded and the friction-speed relationship may be plotted.

5. Significance and Use

5.1 This test method provides a measure of surface friction as a function of sliding speed, either in the field or in a laboratory.

5.2 This test method may be used to determine the relative effects of various polishing techniques on materials or material combinations.

5.3 The values measured in accordance with this method do not necessarily agree or directly correlate with those obtained utilizing other methods of determining friction properties or skid resistance.

6. Apparatus

6.1 *DF Tester* (see Fig. 1)—The measuring instrument consists of a main body and a control unit. A portable personal computer or an X-Y plotter can be used to record the data. Fig. 1 shows the DF Tester measuring unit, consisting of a fly wheel and disc which is driven by a motor. Three rubber sliders are attached to the disc by leaf springs. The sliders are pressed on the test surface by the weight of the device through three rollers. Each slider is loaded to 11.8 N (2.65 lbf) by the leaf springs. The disc and the fly wheel are connected by a spring balance mounted along a circle on which the rubber sliders are fixed. Due to the forces on the rubber sliders, displacement occurs in a spring balance. This displacement is converted to an electrical signal through a displacement transducer with an accuracy of $\pm 1\%$ of full scale attached to the opposite side of the disc. This signal is output through a slip ring and brush, both of which are mounted on a driving shaft. The speed of rubber sliders is measured from the output of a rotational speed dynamo.

6.2 *Water Supply* (see Fig. 2)—A water supply unit is provided to maintain a wet condition of the test surface. When the tank is 0.6 m above the tester a water flow of 3.6 l/min (0.95 gal/min) is maintained. If the flow is initiated when the rotation corresponds to a tangential velocity of 85 km/h (50 mph) the water thickness will be 1 mm (0.04 in.) by the time that the velocity reaches 90 km/h (55 mph) and the measurement is initiated.

6.3 *Slider* (see Fig. 3)—The slider assembly shall consist of a steel backing plate to which is bonded a 6 by 16 by 20 mm (0.25 by 0.63 by 0.79 in.) rubber shaped as shown in Fig. 3. This shape provides a contact pressure of 150 kPa (21.5 lbf/in.²). The rubber compound shall be synthetic rubber as specified in Specification E501 and shall have a shore hardness of 58 ± 2 . The sliders shall be replaced due to waves after twelve runs. The slider production date is given on the plastic bag in which they are shipped. The sliders must be used within twelve months of the production date to avoid effects of passive deterioration.

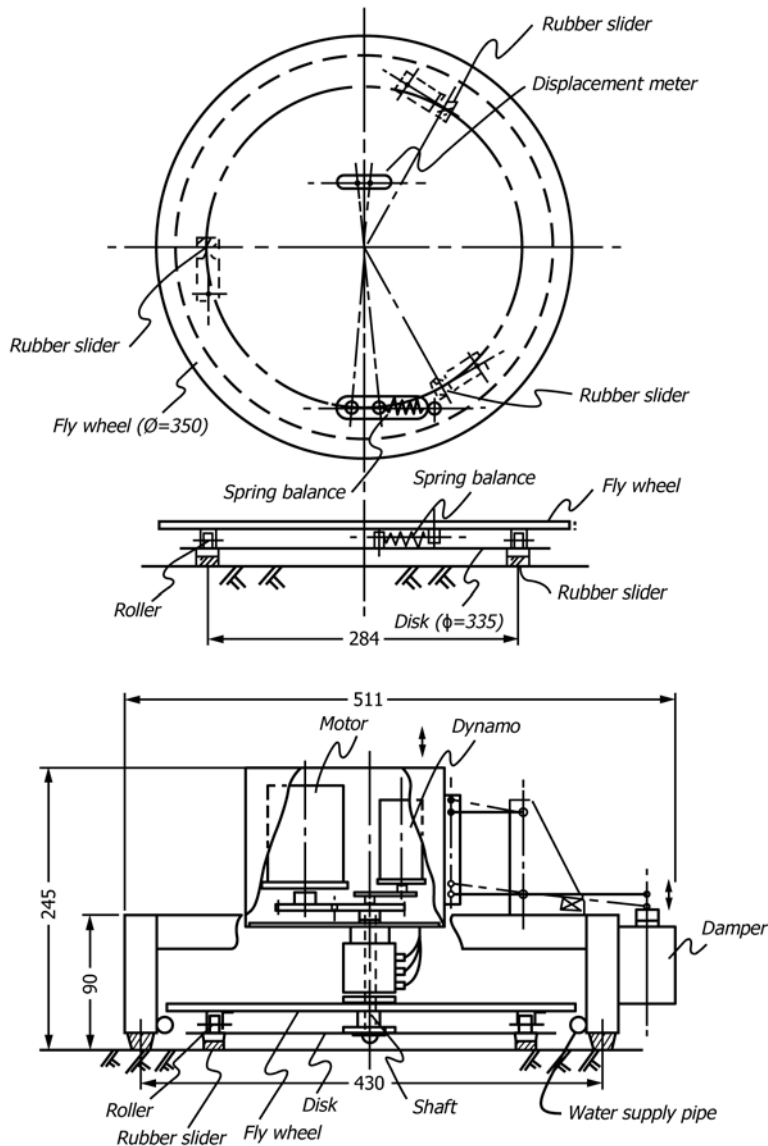
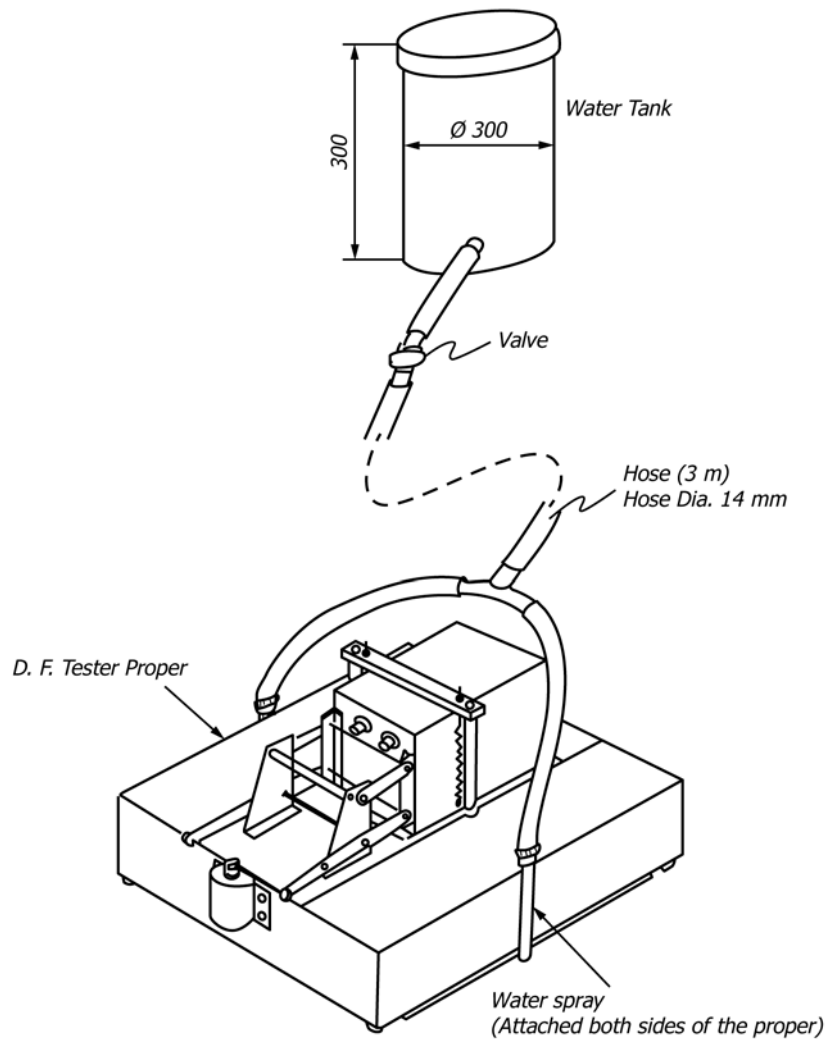

FIG. 1 The DF Testers (Dimensions in. mm: 25.4 mm = 1 in.)



Tank must be placed 60 cms higher than road surface. The amount of spraying water at the height is 60 cc/min.

FIG. 2 The Watering Apparatus

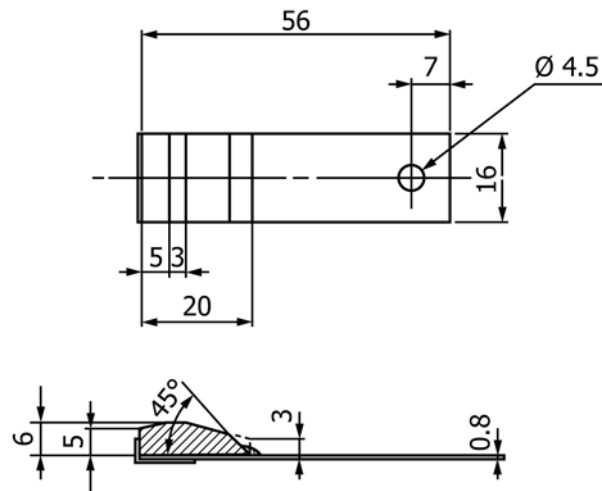

FIG. 3 The Rubber Slider (Dimensions in mm: 25.4 mm = 1 in.)

NOTE 1—On extremely harsh surfaces it may be necessary to replace the sliders more often.

6.4 *Data Collection*—The instantaneous value of the friction is detected as a signal from the force transducer. The vibration during measurement is absorbed by a damper. The signal is filtered by a first order R-C filter with a time constant of 0.1 s. The signal may be saved for future analysis.

6.5 *Data Recording*—The tester can be connected to a personal computer and the data can be displayed on the screen and stored on floppy discs. As an alternative, the friction signal and the speed signal from the rotational speed dynamo can be recorded using an X-Y plotter to provide a paper record of the relation between friction and speed.

6.6 *Calibration*—To determine if the DF Tester should be calibrated measure the friction of a calibration panel supplied by the manufacturer. The calibration panel has been prepared and polished to a stable condition such that the change in friction from the previous measurement is minimal. If the value at 40 km/h is more than ± 0.03 from the last measurement made on the panel, calibration is recommended. Otherwise the unit does not need to be calibrated. It is recognized that over time the panel will be polished by the tests performed on it, so the criterion is based only on the change from the previous test which shall have been recorded and stored with the panel. Care must also be taken in storing the calibration panel so that its surface is not damaged.

NOTE 2—In the event that it is determined the DFTester must be calibrated, calibration should be performed by the manufacturer's calibration facility.

7. Test Samples

7.1 *Field*—Field test surfaces shall be free of loose particles and flushed with clean water. The test surface does not have to be horizontal provided the instrument can be leveled in working position.

7.2 *Laboratory*—Laboratory test panels shall be clean and free of loose particles and shall be held rigidly so as not to be moved by the forces during measurement.

7.2.1 Flat laboratory test panels shall have a test surface of at least 600 by 600 mm (24 by 24 in.) with no disturbance from edge effects for a diameter of 500 mm (20 in.).

8. Procedure

8.1 Place the DF Tester on the test sample that should be level and free of any contamination.

NOTE 3—It is preferable to operate the DF Tester at a location where the surface is flat. However, the effect of slope on the results is due to the

decrease of the vertical load on the sliders by the cosine of the slope angle. Therefore a slope of 20 % will decrease the vertical load by only 2 %. Slopes higher than 30 % are not recommended.

8.2 Start the rotation of the disk. Verify that the fly wheel and disc with three rubber sliders rotates without contacting the test surface, and start the water supply.

8.3 When the rotating speed reaches a target speed, water flow is closed and the driving device is lowered to the test surface.

8.4 The measurement begins, the speed of the driving device gradually decreases due to the friction between rubber sliders and the test surface, and finally stops.

8.5 Record the test results or store the data for future analysis.

9. Report

9.1 Report the following information:

9.1.1 Date and time of day,

9.1.2 Individual values of the friction DFT Numbers for speeds of 20, 40, 60, and 80 km/h (12, 24, 36, and 48 mph),

9.1.3 Temperature of the test surface,

9.1.4 Type, age, condition, and location of test surface,

9.1.5 Shore hardness and production date of the rubber sliders,

9.1.6 Plot of the friction-speed curve, and

9.1.7 Type and date of the most recent calibration.

10. Precision and Bias

10.1 *Precision*—The standard deviation of eight measurements on the same test surface ranged from 0.044 at 30 km/h to 0.038 at 60 km/h.³

10.2 *Bias*—There is no basis for determination of the bias.

NOTE 4—Results from the International PIARC Experiment to Compare and Harmonize Texture and Skid Resistance Measurements⁴ indicated a correlation with the Skid Numbers from Test Method E274 produced a correlation coefficient (R) of 0.86. The results also showed that, when used with a measure of Mean Profile Depth, the International Friction Index can be determined by the DF Tester within ± 0.027 .

11. Keywords

11.1 friction; pavements; skid resistance

³ Saito, K., Horiguchi, T, Kasahara, A., Abe, H., and Henry, J.J., *Development of a Portable Tester for Measuring Skid Resistance and its Speed Dependency on Pavement Surfaces*, Transportation Research Record 1536, Washington, DC 1996, pp. 45-51.

⁴ Wambold, J. C., Antle, C.E., Henry, J. J., and Rado, Z, International PIARC Experiment to Compare and Harmonize Texture and Skid Resistance Measurements, Final Report, *Permanent International Association of Road Congresses* (PIARC), Paris 1995.

ASTM International takes no position respecting the validity of any patent rights asserted in connection with any item mentioned in this standard. Users of this standard are expressly advised that determination of the validity of any such patent rights, and the risk of infringement of such rights, are entirely their own responsibility.

This standard is subject to revision at any time by the responsible technical committee and must be reviewed every five years and if not revised, either reapproved or withdrawn. Your comments are invited either for revision of this standard or for additional standards and should be addressed to ASTM International Headquarters. Your comments will receive careful consideration at a meeting of the responsible technical committee, which you may attend. If you feel that your comments have not received a fair hearing you should make your views known to the ASTM Committee on Standards, at the address shown below.

This standard is copyrighted by ASTM International, 100 Barr Harbor Drive, PO Box C700, West Conshohocken, PA 19428-2959, United States. Individual reprints (single or multiple copies) of this standard may be obtained by contacting ASTM at the above address or at 610-832-9585 (phone), 610-832-9555 (fax), or service@astm.org (e-mail); or through the ASTM website (www.astm.org). Permission rights to photocopy the standard may also be secured from the Copyright Clearance Center, 222 Rosewood Drive, Danvers, MA 01923, Tel: (978) 646-2600; <http://www.copyright.com/>