



# Standard Practice for Describing and Specifying a Direct Current Plasma Atomic Emission Spectrometer<sup>1</sup>

This standard is issued under the fixed designation E1832; the number immediately following the designation indicates the year of original adoption or, in the case of revision, the year of last revision. A number in parentheses indicates the year of last reapproval. A superscript epsilon ( $\epsilon$ ) indicates an editorial change since the last revision or reapproval.

## 1. Scope

1.1 This practice describes the components of a direct current plasma (DCP) atomic emission spectrometer. This practice does not attempt to specify component tolerances or performance criteria. This practice does, however, attempt to identify critical factors affecting bias, precision, and sensitivity. A prospective user should consult with the vendor before placing an order to design a testing protocol for demonstrating that the instrument meets all anticipated needs.

1.2 *This standard does not purport to address all of the safety concerns, if any, associated with its use. It is the responsibility of the user of this standard to establish appropriate safety and health practices and determine the applicability of regulatory limitations prior to use. Specific hazards statements are given in Section 9.*

## 2. Referenced Documents

### 2.1 ASTM Standards:<sup>2</sup>

[E135 Terminology Relating to Analytical Chemistry for Metals, Ores, and Related Materials](#)

[E158 Practice for Fundamental Calculations to Convert Intensities into Concentrations in Optical Emission Spectrochemical Analysis](#) (Withdrawn 2004)<sup>3</sup>

[E172 Practice for Describing and Specifying the Excitation Source in Emission Spectrochemical Analysis](#) (Withdrawn 2001)<sup>3</sup>

[E406 Practice for Using Controlled Atmospheres in Spectrochemical Analysis](#)

[E416 Practice for Planning and Safe Operation of a Spectrochemical Laboratory](#) (Withdrawn 2005)<sup>3</sup>

<sup>1</sup> This practice is under the jurisdiction of ASTM Committee E01 on Analytical Chemistry for Metals, Ores, and Related Materials and is the direct responsibility of Subcommittee E01.20 on Fundamental Practices.

Current edition approved Dec. 1, 2012. Published December 2012. Originally approved in 1996. Last previous edition approved in 2003 as E1832 – 03, which was withdrawn October 2004 and reinstated in May 2008. DOI: 10.1520/E1832-08R12.

<sup>2</sup> For referenced ASTM standards, visit the ASTM website, [www.astm.org](http://www.astm.org), or contact ASTM Customer Service at [service@astm.org](mailto:service@astm.org). For Annual Book of ASTM Standards volume information, refer to the standard's Document Summary page on the ASTM website.

<sup>3</sup> The last approved version of this historical standard is referenced on [www.astm.org](http://www.astm.org).

[E520 Practice for Describing Photomultiplier Detectors in Emission and Absorption Spectrometry](#)

[E528 Practice for Grounding Basic Optical Emission Spectrochemical Equipment](#) (Withdrawn 1998)<sup>3</sup>

[E1097 Guide for Determination of Various Elements by Direct Current Plasma Atomic Emission Spectrometry](#)

## 3. Terminology

3.1 For terminology relating to emission spectrometry, refer to Terminology [E135](#).

## 4. Significance and Use

4.1 This practice describes the essential components of the DCP spectrometer. This description allows the user or potential user to gain a basic understanding of this system. It also provides a means of comparing and evaluating this system with similar systems, as well as understanding the capabilities and limitations of each instrument.

## 5. Overview

5.1 A DCP spectrometer is an instrument for determining concentration of elements in solution. It typically is comprised of several assemblies including a direct current (dc) electrical source, a sample introduction system, components to form and contain the plasma, an entrance slit, elements to disperse radiation emitted from the plasma, one or more exit slits, one or more photomultipliers for converting the emitted radiation into electrical current, one or more electrical capacitors for storing this current as electrical charge, electrical circuitry for measuring the voltage on each storage device, and a dedicated computer with printer. The liquid sample is introduced into a spray chamber at a right angle to a stream of argon gas. The sample is broken up into a fine aerosol by this argon stream and carried into the plasma produced by a dc-arc discharge between a tungsten electrode and two or more graphite electrodes. When the sample passes through the plasma, it is vaporized and atomized, and many elements are ionized. Free atoms and ions are excited from their ground states. When electrons of excited atoms and ions fall to a lower-energy state, photons of specific wavelengths unique to each emitting species are emitted. This radiation, focussed by a lens onto the entrance slit of the spectrometer and directed to an echelle grating and

quartz prism, is dispersed into higher orders of diffraction. Control on the diffraction order is accomplished by the low-dispersion echelle grating. Radiation of specific wavelength or wavelengths passes through exit slits and impinges on a photomultiplier or photomultipliers. The current outputs charge high-quality capacitors, and the voltages thus generated are measured and directed to the computer. Using calibration solutions, a calibration curve is generated for each element of interest. The computer compares the signals arising from the many elements in the sample to the appropriate calibration curve and then calculates the concentration of each element. Over seventy elements may be determined. Detection limits in a simple aqueous solution are less than 1 mg/L for most of these elements. Mineral acids or organic liquids also may be used as solvents, and detection limits are usually within an order of magnitude of those obtained with water. Detection limits may be improved by using preconcentration procedures. Solid samples are dissolved before analysis.

## 6. Description of Equipment

6.1 *Echelle Spectrometer*—Components of the equipment shown in Fig. 1 and described in this section are typical of a commercially available spectrometer. Although a specific spectrometer is described herein, other spectrometers having equal or better performance may be satisfactory. The spectrometer is a Czerny-Turner mount and consists of a condensing lens in front of an entrance slit, a collimating mirror, combined dispersing elements (grating and prism), focus mirror, exit slits, photomultipliers, control panel, and wavelength selector mechanism.

6.1.1 *Condensing Lens*, placed between the DCP source and the entrance slit. It should have a focal length capable of focusing an image of the source on the entrance slit and with sufficient diameter to fill the aperture of the spectrometer with radiant energy.

6.1.2 *Entrance Slit*, although available with fixed width and height, a slit variable in both width and height provides greater flexibility. Typical values are 0.025 mm to 0.500 mm in width and 0.100 mm to 0.500 mm in height. Adjustable slit widths and heights are useful in obtaining optimal spectral band width and radiant energy entering the spectrometer for the requirements of the analytical method.

6.1.3 *Collimating Mirror*, renders all rays parallel after entering the spectrometer. These parallel rays illuminate the combined dispersing elements. The focal length and  $f$  number should be specified. Typical focal length and  $f$  number are 750 mm and  $f/13$ .

6.1.4 *Combined Dispersing Components*, positioned so that the radiant energy from the collimating mirror passes through the prism, is refracted and reflected by a plane grating and back through the prism. Specify the ruling on the grating (for example, 79 grooves/mm).

6.1.5 *Focus Mirror*, placed to focus the radiant energy from the combined dispersing elements on a flat two-dimensional focal plane where the exit slits are located.

6.1.6 *Fixed Exit Slits*, mounted in a removable fixture called an optical cassette for multielement capability. A two-mirror periscope behind each exit slit directs the radiant energy to a

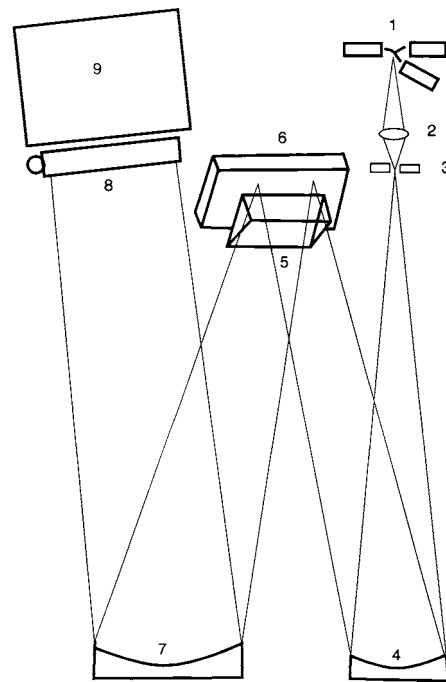

- |                      |                       |                 |
|----------------------|-----------------------|-----------------|
| 1. PLASMA JET        | 4. COLLIMATING MIRROR | 7. FOCUS MIRROR |
| 2. LENS              | 5. PRISM              | 8. CASSETTE     |
| 3. ENTRANCE APERTURE | 6. ECHELLE GRATING    | 9. DETECTOR     |

FIG. 1 Echelle Grating Spectrometer

corresponding photomultiplier. For single element capability, energy for one wavelength usually passes through its exit slit directly to the photomultiplier without the need for a periscope. Select the specific exit slit width before installation. Provide a single channel cassette with one exit slit variable from 0.025 mm to 0.200 mm in width and from 0.100 mm to 0.500 mm in length.

6.1.7 *Photomultipliers*, up to twenty end-on tubes, are mounted behind the focal plane in a fixed pattern. Consider sensitivity at specific wavelength and dark current in the selection of appropriate photomultipliers. Provide variable voltage to each photomultiplier to change its response as required by the specific application. A typical range is from 550 V to 1000 V in 50-V steps. A survey of the properties of photomultipliers is given in Practice E520.

6.1.8 *Control Panels*, are provided to perform several functions and serve as input to microprocessors to control the operation of the spectrometer. Provide a numeric keyboard to enter high and low concentrations of reference materials for calibration and standardization of each channel and to display entered values for verification. Provide a switch on this panel to set the mode either to integrate during analysis or to measure instantaneous intensity. The latter mode is required to obtain the peak position for a specific channel by seeking maximum intensity by wavelength adjustment and verifying by wavelength scanning. Conduct interference and background investigations with this mode. Scanning is required if automatic background correction is to be performed. Provide other necessary switches for the following purposes: to calibrate or standardize the spectrometer, start analysis, interrupt the function being performed, set integration time and the number of

replicate analyses, and direct the output to a printer, display, or storage medium. Impose a fixed time delay of 10 s before integration can begin to ensure that the solution being analyzed is aspirated into the DCP discharge. Provide digital and analog voltmeters for displaying the instantaneous or integrated intensities during peaking, scanning, or analysis. If a computer is an integral part of the spectrometer, most of the control functions are accomplished with software.

6.1.9 *Wavelength Adjustment*, provided to adjust the wavelength range and diffraction order for peaking the spectrometer because a two-dimensional spectrum is produced. Both coarse and final control of these adjustments are required. To maintain optical alignment, the spectrometer should be thermally isolated from the DCP source or heated. A heated base on which the spectrometer rests has been satisfactory for this purpose.

6.1.10 *Dispersion and Spectral Band Pass*—Typical dispersion and spectral band pass with a 0.025-mm slit width vary from 0.061 nm/mm and 0.0015 nm at 200 nm to 0.244 nm/mm and 0.0060 nm at 800 nm, respectively.

6.2 *DCP Source*, composed of several distinct parts, namely the electrode, direct current power supply, gas flow, sample introduction, exhaust, water cooling, and safety systems. Refer to Practice E172 for a list of the electrical source parameters that should be specified in a DCP method.

6.2.1 *Electrode System*, Fig. 2, consists of two graphite anodes fixed in a vertical plane and at a typical angle of 60° to one another, and a tungsten cathode fixed in a horizontal plane at an angle of 45° to the optic axis. In their operating position, the tips of the two anodes are separated by a distance of  $1\frac{3}{16}$  in., (3.0 cm), and the tungsten cathode is  $1\frac{5}{8}$  in., (4.1 cm), above the anode tips. Each electrode is recessed in a ceramic sleeve fitted into water-cooled anode and cathode blocks. Because the electrodes are of special design to fit into and be held by these blocks, the user must follow the manufacturer's recommendations for these electrodes. The electrode system shall provide mechanism to adjust the electrodes vertically and horizontally across the optic axis to properly project the image of the excitation region onto the entrance slit and obtain a maximum signal-to-noise ratio. Sometimes a visible excitation region is not produced when some specimens are aspirated into this source. Iron solutions, as well as solutions of several other elements, however, are satisfactory for this purpose.

6.2.2 *Direct Current Power Supply*, capable of maintaining a constant current of 7 A dc in the discharge with a voltage of 40 V to 50 V dc between the anodes and cathodes. The resulting discharge has the shape of an inverted letter Y with a luminous zone in the crotch of the Y.

6.2.3 *Gas Flow System*, (Refer to Practice E406) shall be capable of the following:

6.2.3.1 Providing argon gas delivered at a pressure of 80 psi (5.62 kg/cm<sup>2</sup>) to the discharge sustaining gas and sample nebulization.

6.2.3.2 Providing a pneumatic system to extend the anode and cathode out of their sleeves and move the cathode block downwards so that the cathode electrode makes contact with one of the anodes and initiates the plasma.

6.2.3.3 Providing gas pressures of 15 psi to 30 psi (1.05 kg/cm<sup>2</sup> to 2.01 kg/cm<sup>2</sup>) for nebulization and 50 psi (3.52

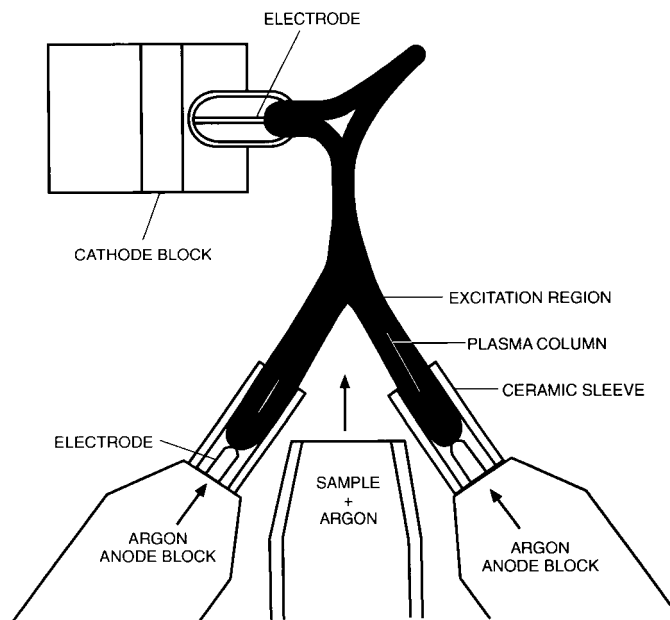

FIG. 2 DCP Source

kg/cm<sup>2</sup>) for other functions. Needle valves are used to adjust these pressures, as well as provide for division of gas flows among three electrode blocks. A balance among the gas flows through these blocks and past the electrodes is necessary to produce and maintain a symmetrical discharge and a triangular- or arrowhead-shaped excitation region where the specimen's spectrum is generated.

6.2.3.4 Providing isolation of the gas flow system from the ambient atmosphere. For good analytical performance, ensure that all tubing connections are tight and O-rings are in good condition.

6.2.4 *Sample Introduction System* is required to control the flow of sample solution. This typically involves placing a flexible tube in the sample container, which aspirates the sample solution into a nebulizer, usually a cross-flow design. A peristaltic pump is used to pump the sample solution to the nebulizer. As a specimen drop is formed at the nebulizer orifice (0.02 in. or 0.05 cm), it is removed by the argon stream and broken into several smaller drops. Most of these impinge on the walls of the spray chamber running down to collect in a waste reservoir. Typically, about 20 % of the nebulized specimen is carried by the argon stream as an aerosol into the plasma. The liquid in the waste reservoir is removed continuously by the same peristaltic pump used to feed the nebulizer, and passes the waste through a second tube to be safely disposed. If this is not done, the volume of liquid waste in the reservoir and the spray chamber is increased, increasing the gas pressure and volume of the specimen injected into the plasma, thus extinguishing the plasma. Because this pump crushes these tubes with use, daily damage inspection is required for optimum performance.

6.2.5 *Exhaust System*—Provide a small hood connected to an exhaust fan above the plasma cabinet to remove the waste gases. The fan should have a capacity to move 100 ft<sup>3</sup>/min (47.2 L/s). The flow rate should be adjustable to efficiently



remove these gases, and the hood, duct, and fan should be compatible for use with chemicals contained in typical sample solutions.

**6.2.6 Water Cooling System**—Circulate water through the electrode blocks using either the laboratory's water supply or water pumped from a reservoir located near the spectrometer. Cooling is required to remove heat generated in the electrodes by the plasma and to protect seals in the electrode blocks. Provide a temperature sensor to turn off the plasma when the water flow is too small. Argon flow through the blocks and sleeves does not provide sufficient cooling.

**6.2.7 Safety Systems**—In addition to those safety features described in Practice E416 concerning the viewing of the plasma, exhaust gas ventilation and electrical grounding (Practice E528) provide a door interlock to shut off the plasma when the door is opened. Because the ceramic sleeves and electrodes are hot for several seconds after the plasma is extinguished, they should not be touched after use for at least 30 s whenever they are changed or other maintenance of the source is performed.

**6.3 Signal Processing and Display**—Radiation produced in the plasma is dispersed by the prism-grating optics during specimen analysis. It impinges on each photomultiplier and is converted to an electrical current, which is integrated on a capacitor for the specified analytical item. In the calibration mode, data obtained during analysis of the high concentration standard are used for autoranging to obtain a final integrated value of approximately 5000 mV to 6000 mV. Data obtained during the analysis of the low concentration standard in this mode are used with the high standard data and the corresponding concentrations to calculate and store coefficients for a straight-line analytical curve for each channel. In the standardization mode, these data are used only to update values of the coefficients. In the specimen analysis mode, these coefficients are used to convert integrated voltages to concentrations. Voltages and concentrations for each replicate analysis, average concentrations and standard deviations are printed, and if a separate computer is available, are displayed on its monitor and stored on cartridge tape or disk.

## 7. Additional Equipment

**7.1 Autosampler**—Provide a device for automatic selection and introduction of liquid specimens for calibration and standardization of the spectrometer and analysis of specimens of unknown composition. An autosampler is characterized by the number of specimens that can be analyzed unattended, maximum specimen volume, and a time delay that can be specified to ensure sufficient time has elapsed for the liquid to enter the plasma.

**7.2 Computer**—Commercially available instruments may include a dedicated computer, tape or disk drive, and terminal, often with graphics capability. The use of this equipment provides additional but optional computational capabilities than the microprocessor described in 6.1.8 and is required if an autosampler is used. The software shall provide means for analytical and scanning results to be displayed on a monitor and also to be stored on cartridge tape or disk. Provide means for correcting analytical results for interferences and nonlin-

earity of the analytical curve before display and storage (see Practice E158). Provide the user with the ability to make correlations between two sets of data, curve-fit data to at least a second-degree polynomial, compare scans, and edit data.

**7.3 Dynamic Background Corrector**—Provide a device useful for performing spectral scans to determine background and interference effects and confirming that the spectrometer is properly peaked. Select positions at which measurements are to be made for background corrections. During analysis, background intensities are measured with this device at previously determined positions by scanning and corrections made automatically with the microprocessor or computer to obtain the true peak intensity. It is recommended that a DCP spectrometer be equipped with such a device to perform these functions.

## 8. Performance Characteristics

**8.1** The following subsections set forth criteria by which performance may be described.

**8.1.1 Dynamic Range**—Radiation of a specific wavelength emitted by a DCP source is linear over a range covering as much as six decades of elemental concentration. The electronic system shall have a linear dynamic range of not less than six orders of magnitude so that any departure from linearity of the analytical curve within this range is a result of self-absorption occurring in the plasma. Directions for determining linear dynamic range are found in Guide E1097.

**8.1.2 Stability**—The stability of the instrument, as measured by the repeatability for an elemental determination, is dependent on the alignment of the image of the excitation region with the entrance slit, argon gas flow, and its isolation from the ambient atmosphere, control of ambient air temperature, condition of the nebulizer, tubing and peristaltic pump, and sealing of the spectrometer against light leaks. Under routine operating conditions, the relative standard deviation shall be equal to or better than 1 % for 10 consecutive measurements when the integration time is 10 s and the elemental concentration is 1000 times the accepted limit of detection.

**8.1.3 Detection Limit**—For directions on determining the detection limit, refer to Guide E1097. Detection limits determined using aqueous standard solutions are provided for reference in Table 1. Actual detection limits may vary significantly from these values.

## 9. Instrument Optimization

**9.1** Each of the following sections deals with components or analysis characteristics, or both, that must be considered during optimization.

**9.1.1 Detector Design**—In designing a polychromator, selection of fixed wavelengths requires close collaboration between the user and manufacturer. In one commercially available instrument, the photomultipliers are mounted in a hexagonal pattern to receive radiation through a window mounted on the end of the tube. Radiation of each specific wavelength passes through an exit slit mounted in a cassette and then directed by two mirrors mounted as a small periscope in the cassette for each photomultiplier. If the presence of other concomitants causes spectral overlap or requires photomultipliers to be too close together, it also may be necessary to select

**TABLE 1 Analytical Lines and Detection Limits**

Element	Analytical Lines, nm	Detection Limit, mg/L
Aluminum	396.152	0.002
Antimony	231.147	0.05
Arsenic	193.696	0.08
Barium	455.403	0.0003
Beryllium	313.042	0.0003
Bismuth	223.061	0.09
Boron	249.773	0.005
Cadmium	228.802	0.005
Calcium	393.366	0.0007
Cerium	394.275	0.03
Cesium	455.531	0.8
Chromium	425.435	0.002
Cobalt	340.512	0.005
Copper	327.396	0.002
Dysprosium	400.045	0.003
Erbium	390.631	0.002
Europium	420.505	0.002
Gadolinium	364.619	0.007
Gallium	403.298	0.003
Germanium	265.118	0.01
Gold	242.795	0.008
Hafnium	282.022	0.01
Holmium	345.600	0.002
Indium	451.131	0.004
Iridium	322.078	0.02
Iron	371.994	0.005
Lanthanum	408.672	0.003
Lead	368.348	0.01
Lithium	610.362	0.002
Lutetium	261.542	0.002
Magnesium	279.553	0.0002
Manganese	259.373	0.002
Mercury	253.652	0.02
Molybdenum	379.825	0.004
Neodymium	430.358	0.005
Nickel	341.476	0.002
Niobium	407.973	0.004
Osmium	305.866	0.02
Palladium	340.458	0.002
Phosphorus	213.618	0.09
Platinum	265.945	0.02
Potassium	769.896	0.02
Praseodymium	440.882	0.006
Rhenium	346.046	0.01
Rhodium	369.236	0.001
Rubidium	780.023	0.02
Ruthenium	372.803	0.002
Samarium	442.434	0.004
Scandium	361.384	0.0004
Selenium	196.026	0.1
Silicon	288.158	0.01
Silver	328.068	0.004
Sodium	589.592	0.003
Strontium	407.771	0.0003
Tantalum	296.513	0.02
Tellurium	214.281	0.2
Terbium	367.635	0.006
Thallium	535.046	0.003
Thorium	401.913	0.02
Thulium	313.126	0.002
Tin	283.999	0.02
Titanium	323.452	0.002
Tungsten	400.875	0.02
Uranium	424.167	0.04
Vanadium	309.311	0.002
Ytterbium	398.799	0.0006
Yttrium	437.494	0.002
Zinc	202.548	0.006
Zirconium	339.198	0.004

another, and perhaps less-sensitive line, to avoid spectral interferences. It also may be desirable to incorporate two

detectors to cover the complete range of concentrations of an element in a specific matrix. The manufacturer also should provide detailed information of costs and downtime to add one or more elements at the user's site.

**9.1.2 Wavelength, Sequential Systems**—When only one photomultiplier is present, analysts performing determinations of one element must select optimal lines. Useful lines for this purpose are listed in **Table 1**. Because selected lines must afford sensitivity appropriate for the required range of analyte concentrations, it may be desirable to use two or more lines of differing sensitivity. Line selection also should minimize the number and magnitude of spectral interferences from other analytes. Spectral background, normally not a problem, should be as low as possible.

**9.1.3 Optical Alignment**—Maximum performance of a DCP spectrometer requires careful positioning of each exit slit in a cassette during initial installation. Furthermore, such performance only can be maintained if the observation position within the image of the excitation region on the entrance slit, argon gas pressures, and distribution of gas flow rates among the three electrode blocks are adjusted carefully. The manufacturer should specify the optimized conditions for DCP analysis for a specified matrix and recommend wavelengths for the elements to be determined. In practice, compromise values for some of these conditions may be made to perform simultaneous multichannel analysis with the least loss in sensitivity because the maximum signal-to-noise ratio for each element occurs at different positions in the excitation region.

**9.1.4 Interferences**—There are several possible sources of interference described in **9.1.4.1-9.1.4.3**.

**9.1.4.1 Differences in viscosity, total dissolved solids, pH, surface tension, and other physical properties between sample and reference solutions may give rise to variations in transport efficiency.**

**9.1.4.2 Potential spectral overlaps from concomitant elements may be estimated by measuring the signal emitted by the analysis of a single-element solution. Because the magnitude of the interference may not be directly proportional to concentration, determine the magnitude at several concentrations. This effect generally may be described by a first- or second-degree polynomial. It is useful to consult wavelength tables to determine possible spectral overlaps. The analyst also must be aware of the possible spectral interference from a concomitant element that is not being determined. It may be necessary to install additional computing hardware to correct for the presence of concomitant elements or to allow determination of a given element at two or more wavelengths. With single element determinations, it is possible to determine the concentrations of interfering elements and correct for these interferences.**

**9.1.4.3 Easily ionizable elements, such as lithium, sodium, or potassium, may enhance the emission of other elements. This interference may be corrected by (1) matrix matching the composition of the standard solutions with that of the specimens' solutions; (2) determining the interference by preparing and analyzing specimen solutions containing a range of concentrations of the interfering element; (3) adding large amounts**

of an easily ionizable element to the specimens and standard solutions; or (4) removing the interfering element chemically.

## 10. Training

10.1 The vendor should provide training in safety, basic theory of DCP spectrochemical analysis, operations of hardware and software, and routine maintenance for at least one operator. Training ideally should consist of the basic operation of the instrument at the time of installation, followed by an in-depth course within 60 days.

## 11. Safety Features

11.1 *DC-Arc Source*—The dc-arc source must be equipped with paneling to prevent access during operation. The door allowing access for maintenance must include a *safety interlock* to turn off power if it is opened. The safest precaution is to disconnect power from the instrument before maintenance is begun (see Practice E416). It is recommended strongly that only trained electronics technicians perform other than routine maintenance.

11.2 *Excitation Stand*—In operation, the DCP produces extremely intense ultraviolet radiation, capable of causing severe eye damage (see Practice E416). The door to this stand should be interlocked so that the power to the plasma is cut off, if it is opened, to prevent the operator from receiving an ultraviolet burn or electrical shock.

11.3 *Burn Hazard*—The graphite electrodes and ceramic sleeves become very hot during operation of the DCP. The operator should allow the source to cool for several minutes before attempting to replace these items.

11.4 *Venting*—Samples passing through the plasma may give rise to airborne toxic substances. Also, operation of the DCP dissipates large quantities of heat. The excitation stand must be vented from the laboratory in an environmentally acceptable manner. See Practice E416 and 6.2.4 of this practice.

11.5 *Liquid Waste*—Because much of the sample solution is rejected by the spray chamber, it must be collected and discarded in accordance with environmental regulations. Care must be taken to ensure that any incompatible wastes are collected in separate containers before ultimate disposal. See Practice E416.

11.6 *Emergency Shutdown*—The instrument must be equipped with safety interlocks to turn off power in case cooling water falls below acceptable levels.

11.7 *Additional Information*—For specific details concerning safety procedures, consult Practice E416 and E528.

## 12. Keywords

12.1 atomic emission spectrometer ; DCP; direct current plasma

*ASTM International takes no position respecting the validity of any patent rights asserted in connection with any item mentioned in this standard. Users of this standard are expressly advised that determination of the validity of any such patent rights, and the risk of infringement of such rights, are entirely their own responsibility.*

*This standard is subject to revision at any time by the responsible technical committee and must be reviewed every five years and if not revised, either reapproved or withdrawn. Your comments are invited either for revision of this standard or for additional standards and should be addressed to ASTM International Headquarters. Your comments will receive careful consideration at a meeting of the responsible technical committee, which you may attend. If you feel that your comments have not received a fair hearing you should make your views known to the ASTM Committee on Standards, at the address shown below.*

*This standard is copyrighted by ASTM International, 100 Barr Harbor Drive, PO Box C700, West Conshohocken, PA 19428-2959, United States. Individual reprints (single or multiple copies) of this standard may be obtained by contacting ASTM at the above address or at 610-832-9585 (phone), 610-832-9555 (fax), or service@astm.org (e-mail); or through the ASTM website (www.astm.org). Permission rights to photocopy the standard may also be secured from the ASTM website (www.astm.org/COPYRIGHT/).*