



Standard Practice for Acousto-Ultrasonic Assessment of Filament-Wound Pressure Vessels¹

This standard is issued under the fixed designation E1736; the number immediately following the designation indicates the year of original adoption or, in the case of revision, the year of last revision. A number in parentheses indicates the year of last reapproval. A superscript epsilon (ϵ) indicates an editorial change since the last revision or reapproval.

1. Scope*

1.1 This practice covers a procedure for acousto-ultrasonic (AU) assessment of filament-wound pressure vessels. Guidelines are given for the detection of defect states and flaw populations that arise during materials processing or manufacturing or upon exposure to aggressive service environments. Although this practice describes an automated scanning mode, similar results can be obtained with a manual scanning mode.

1.2 This procedure recommends technical details and rules for the reliable and reproducible AU detection of defect states and flaw populations. The AU procedure described herein can be a basis for assessing the serviceability of filament-wound pressure vessels.

1.3 The objective of the AU method is primarily the assessment of defect states and diffuse flaw populations that influence the mechanical strength and ultimate reliability of filament-wound pressure vessels. The AU approach and probe configuration are designed specifically to determine composite properties in lateral rather than through-the-thickness directions.²

1.4 The AU method is not for flaw detection in the conventional sense. The AU method is most useful for materials characterization, as explained in Guide E1495, which gives the rationale and basic technology for the AU method. Flaws and discontinuities such as large voids, disbonds, or extended lack of contact of interfaces can be found by other nondestructive examination (NDE) methods such as immersion pulse-echo ultrasonics.

1.5 *Units*—The values stated in SI units are to be regarded as standard. No other units of measurement are included in this practice.

1.6 *This standard does not purport to address all of the safety concerns, if any, associated with its use. It is the responsibility of the user of this standard to establish appropriate safety and health practices and determine the applicability of regulatory limitations prior to use.*

2. Referenced Documents

2.1 ASTM Standards:³

E543 Specification for Agencies Performing Nondestructive Testing

E1001 Practice for Detection and Evaluation of Discontinuities by the Immersed Pulse-Echo Ultrasonic Method Using Longitudinal Waves

E1067 Practice for Acoustic Emission Examination of Fiberglass Reinforced Plastic Resin (FRP) Tanks/Vessels

E1316 Terminology for Nondestructive Examinations

E1495 Guide for Acousto-Ultrasonic Assessment of Composites, Laminates, and Bonded Joints

2.2 ASNT Standards:⁴

ANSI/ASNT CP-189 Personnel Qualification and Certification in Nondestructive Testing

ASNT SNT-TC-1A Personnel Qualification and Certification in Nondestructive Testing

2.3 AIA Standard:⁵

NAS-410 Certification and Qualification of Nondestructive Test Personnel

2.4 ISO Standard:⁶

ISO 9712 Non-destructive Testing—Qualification and Certification of NDT Personnel

3. Terminology

3.1 *Definitions*—Relevant terminology and nomenclature are defined in Terminology E1316 and Guide E1495.

¹ This practice is under the jurisdiction of ASTM Committee E07 on Nondestructive Testing and is the direct responsibility of Subcommittee E07.04 on Acoustic Emission Method.

Current edition approved June 1, 2015. Published June 2015. Originally approved in 1995. Last previous edition approved in 2010 as E1736-10. DOI: 10.1520/E1736-15.

² Vary, A., "Acousto-Ultrasonics," *Nondestructive Testing of Fibre-Reinforced Plastics Composites*, Vol 2, J. Summerscales, ed., Elsevier Science Publishers Ltd., Barking, Essex, England, 1990, Chapter 1, pp. 1-54.

³ For referenced ASTM standards, visit the ASTM website, www.astm.org, or contact ASTM Customer Service at service@astm.org. For *Annual Book of ASTM Standards* volume information, refer to the standard's Document Summary page on the ASTM website.

⁴ Available from American Society for Nondestructive Testing (ASNT), P.O. Box 28518, 1711 Arlingate Ln., Columbus, OH 43228-0518, <http://www.asnt.org>.

⁵ Available from Aerospace Industries Association of America, Inc. (AIA), 1000 Wilson Blvd., Suite 1700, Arlington, VA 22209-3928, <http://www.aia-aerospace.org>.

⁶ Available from International Organization for Standardization (ISO), 1, ch. de la Voie-Creuse, CP 56, CH-1211 Geneva 20, Switzerland, <http://www.iso.org>.

*A Summary of Changes section appears at the end of this standard

3.2 Definitions of Terms Specific to This Standard:

3.2.1 composite shell—a multilayer filament-winding that comprises a second shell that reinforces the inner shell. The composite shell consists of continuous fibers, impregnated with a matrix material, wound around the inner shell, and cured in place. An example is the Kevlar-epoxy filament-wound spherical shell shown in Fig. 1. The number of layers, fiber orientation, and composite shell thickness may vary from point to point (Fig. 2). The examination and assessment of the composite shell are the objectives of this practice.

3.2.2 filament-wound pressure vessel—an inner shell over-wrapped with composite layers that form a composite shell. The inner shell or liner may consist of an impervious metallic or nonmetallic material. The vessel may be cylindrical or spheroidal and will have at least one penetration with valve attachments for introducing and holding pressurized liquids or gases.

4. Significance and Use

4.1 The AU method should be considered for vessels that are proven to be free of major flaws or discontinuities as determined by conventional techniques. The AU method may be used for detecting major flaws if other methods are deemed impractical. It is important to use methods such as immersion pulse-echo ultrasonics (Practice E1001) and acoustic emission (Practice E1067) to ascertain the presence of major flaws before proceeding with AU.

4.2 The AU method is intended almost exclusively for materials characterization by assessing the collective effects of dispersed defects and subcritical flaw populations. These are material aberrations that influence AU measurements and also

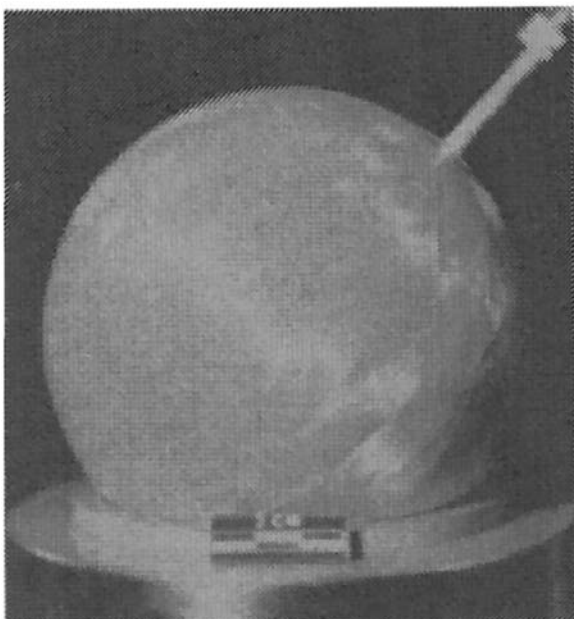

FIG. 1 Kevlar-Epoxy Filament-Wound Shell

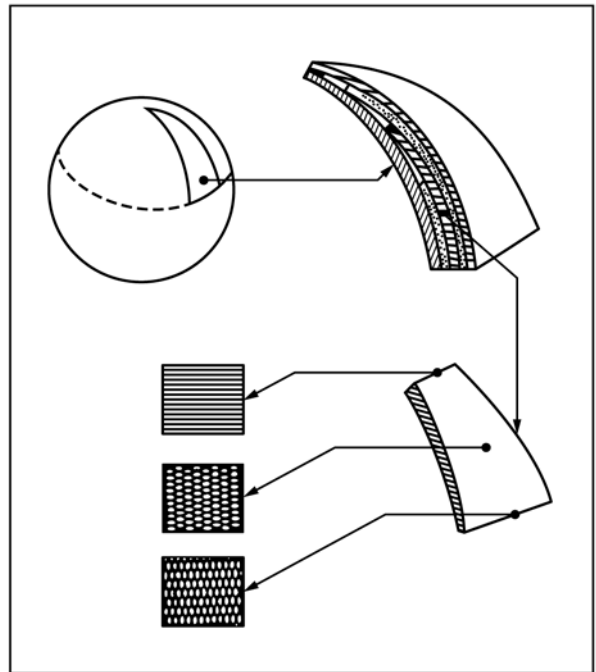

FIG. 2 Representation of Filament-Wound Composite Shell Layers Showing Typical Thicknesses and Layering Variations

underlie mechanical property variations, dynamic load response, and impact and fracture resistance.⁷

4.3 The AU method can be used to evaluate laminate quality using access to only one surface, the usual constraint imposed by closed pressure vessels. For best results, the AU probes must be fixtured to maintain the probe orientation at normal incidence to the curved surface of the vessel. Given these constraints, this practice describes a procedure for automated AU scanning using water squirter to assess the serviceability and reliability of filament-wound pressure vessels.⁸

5. Limitations

5.1 The AU method possesses the limitations common to all ultrasonic methods that attempt to measure either absolute or relative attenuation. When instrument settings and probe configurations are optimized for AU, they are unsuitable for conventional ultrasonic flaw detection because the objective of AU is not the detection and imaging of individual micro- or macro-flaws.

5.2 The AU results may be affected adversely by the following factors:

- (1) couplant (squirter or water jet) variations and bubbles,
- (2) vessel surface texture and roughness,
- (3) improper selection of probe characteristics (center frequency and bandwidth),

⁷ Vary, A., "Material Property Characterization," *Nondestructive Testing Handbook—Ultrasonic Testing*, Vol 7, A. S. Birks, R. E. Green, Jr., and P. McIntire, eds., American Society for Nondestructive Testing, Columbus, OH, 1991, Section 12, pp. 383–431.

⁸ Sundaresan, M. J., Henneke, E. G., and Brosey, W. D., "Acousto-Ultrasonic Investigation of Filament-Wound Spherical Pressure Vessels," *Materials Evaluation*, Vol 49, No. 5, 1991, pp. 601–6012.

- (4) probe misalignment,
- (5) probe resonances and insufficient damping, and
- (6) inadequate instrument (pulsar-receiver) bandwidth.

5.3 Misinterpretations of AU results can occur if there are intermittent disbonds or gaps in the composite shell or at the interface between the composite and inner shell. Using conventional flaw detection methods, care should be taken to ensure that major delaminations, disbonds, or gaps are not present. Extensive gaps or disbonds will produce the same effect as low attenuation within the composite shell by causing more energy to be reflected or channeled to the receiving probe.

6. Basis of Application

6.1 The following items are subject to contractual agreement between the parties using or referencing the test method.

6.2 Personnel Qualification

6.2.1 If specified in the contractual agreement, personnel performing examinations to this standard shall be qualified in accordance with a nationally or internationally recognized NDT personnel qualification practice or standard such as ANSI/ASNT-CP-189, ASNT SNT-TC-1A, NAS-410, ISO 9712, or a similar document and certified by the employer or certifying agency, as applicable. The practice or standard used and its applicable revision shall be identified in the contractual agreement between the using parties.

6.2.2 *Personnel Training*—Training in the following topics is recommended for personnel who perform examinations.

- 6.2.2.1 Failure mechanisms in fiber reinforced plastics
- 6.2.2.2 Ultrasonic instrument and search unit checkout on fiber reinforced plastics.
- 6.2.2.3 Technology of ultrasonic examination of fiber reinforced plastics.

6.3 *Qualification of Nondestructive Agencies*—If specified in the contractual agreement, NDT agencies shall be qualified and evaluated as described in Practice E543. The applicable edition of Practice E543 shall be specified in the contractual agreement.

6.4 *Timing of Examination*—Examinations shall be performed as desired during the manufacture and use of the vessels.

6.5 *Extent of Examination*—The extent of examination shall be in accordance with 9.1.1 unless otherwise specified.

6.6 *Reporting Criteria/Acceptance Criteria*—Reporting criteria for the examination results shall be in accordance with 10 unless otherwise specified. Since acceptance criteria are not specified in this standard, they shall be specified in the contractual agreement.

6.7 *Reexamination of Repaired/Reworked Items*—Reexamination of repaired/reworked items is not addressed in this standard and if required shall be specified in the contractual agreement.

7. Apparatus

7.1 The basic apparatus and instrumentation for performing automated AU scanning of filament-wound pressure vessels are shown schematically in Fig. 3.

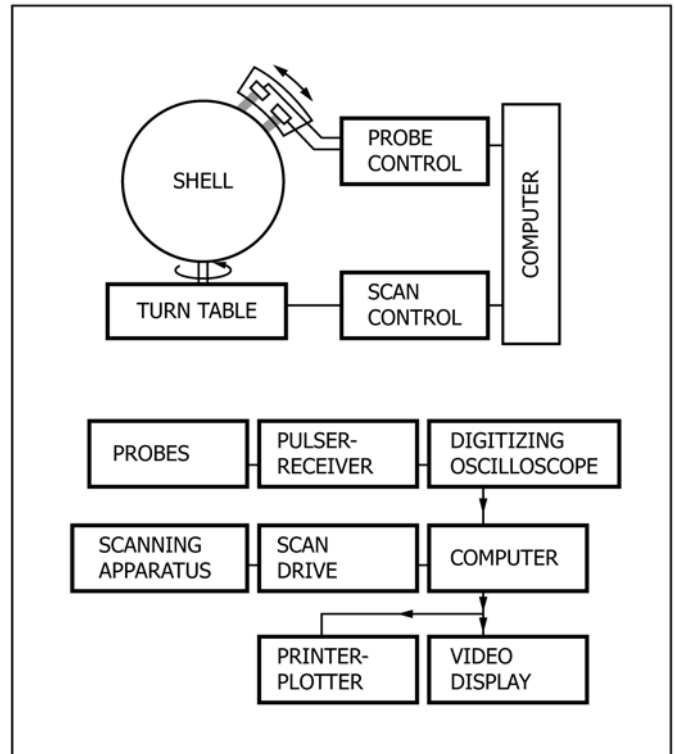

FIG. 3 Schematic Diagram of Scanning Apparatus and Signal Acquisition, Image Processing, and Data Analysis Instrumentation

7.1.1 *Scanning Apparatus*, consisting of a device capable of holding a pressure vessel and rotating it about an axis. The AU probe assembly is mounted in a holder capable of being articulated and indexed in a manner that maintains the probe spacing and probes at a normal incidence angle relative to the vessel surface.

7.1.2 *Acousto-Ultrasonic Probes*—A sender and a receiver, that is, two search units as defined in Terminology E1316.

7.1.2.1 The sender should produce wavelengths in the vessel’s composite filament-wound shell equal to or less than its thickness. For example, for composite shells up to 1 cm thick, the center frequency of the probes should be in the range from 1 to 5 MHz. Probes operating at 2.25 MHz are recommended for general use on polymer or organic matrix composites.

7.1.2.2 The probes should be acoustically coupled individually to the vessel by columns of water, that is, the “squirter” or water jet method.

7.1.2.3 Probe separation (distance between probes) should be fixed at approximately 2 to 5 cm, depending on considerations such as avoiding “cross-talk” reflections, signal attenuation, and the need to include an adequate representative volume of material between the sender and the receiver. The latter requirement is to ensure integrating the effects of diffuse flaw populations in the region being examined currently.

7.1.2.4 A preamplifier is recommended in close proximity to the receiving probe to strengthen the signal it sends to the pulser-receiver. The need to strengthen the signal depends on

the sender-receiver probe spacing, water jet column length, and attenuation by the shell.

7.1.3 *Instrumentation*, for automated scanning and data acquisition and presentation. Essential components consist of a programmable scan drive module, signal digitizing oscilloscope with time base and vertical (voltage) amplifier, computer with an appropriate bus interface, ultrasonic pulser-receiver, digital display, and printer/plotter.

8. Principles of Practice

8.1 The sending probe introduces simulated stress waves in the composite shell. The receiving probe collects the resultant multiple reverberations that are generated. The effects of each local volume or zone of the composite shell on AU stress wave propagation are collected and evaluated.²

8.2 The objective is to measure the relative efficiency of stress wave propagation in the composite shell. The dominant attribute measured is stress wave attenuation, as represented by signal strength or weakness. This measurement is quantified by an AU stress wave factor (SWF) defined in Guide E1495. Lower attenuation corresponds to higher values of the AU SWF.

8.3 At any given location, higher signal strength is a result of better stress wave energy transmission within the composite shell and, therefore, indicates better transmission and redistribution of dynamic strain energy. More efficient strain energy transfer and strain redistribution (for example, during loading or impact) correspond to increased strength and fracture resistance in the composite shell.

8.4 Regions that exhibit lower signal strength are those that attenuate the probe-induced stress waves. These are regions in which the strain energy is likely to concentrate and result in crack growth and fracture upon experiencing impact or high loading.

9. Procedure

9.1 Before AU scanning commences, the sender and receiver probes should be evaluated by comparing the signals with standard waveforms established previously for a reference composite shell. This determines whether there are deficiencies in the instrumentation and probe response.

9.1.1 Consider the following two options before proceeding:

9.1.1.1 *Option 1*—Refer all AU readings on the composite shell being examined to measurements at the same locations on a reference shell that is known to be free of flaws and represents the optimum or most acceptable condition. In this case, AU readings on the test shell are “normalized” against previously recorded AU readings for the same locations on the reference shell.

9.1.1.2 *Option 2*—Refer all AU readings on the composite shell being examined to the highest reading on the same shell. In this case, AU readings on the test shell will demonstrate only nonuniformities in and peculiar to that shell.

9.1.2 Using an optimized reference composite shell, adjust the probes with respect to each other and set the gate that acquires the signal of interest.

9.1.2.1 The signal reaching the receiving probe should resemble that illustrated in Fig. 4. In this case, the received AU signal is the result of propagation through three layers: the inner shell, composite shell, and water layer on the surface.

9.1.2.2 Include only Parts A and B in the gate for signal acquisition and analysis. Part C contains only random fluctuations due to stress waves traveling through the water. Some trials involving (finger) obstruction of the water layer will help define the transition from Part B to Part C. Part A may contain signals from the inner shell, but these constitute a constant factor and need not be of concern.

9.2 Arrange the probes in a send-receive configuration. Before proceeding with an automated scan, position the probes near the surface of the vessel and make a set of initial measurements to optimize the received signal by varying the probe offset (distance between probes), water jet length, and various instrument settings.

9.3 Scan the composite shell by rotating and indexing the shell relative to the probes.

9.3.1 At each grid intersection or zone, orient the probes so that AU measurements are made both circumferentially (latitudinally) and axially (longitudinally), as indicated in Fig. 5.

9.3.2 Program the computer to provide a two-dimensional projection or three-dimensional display of the received AU data.

9.4 Collect the gated and amplified AU signals by using the digitizing oscilloscope. Program the computer to take each signal (waveform) and calculate a root mean square (rms) voltage for it.

NOTE 1—The rms voltage is only one way of quantifying the AU SWF. As explained in Guide E1495, there are other options for quantifying the

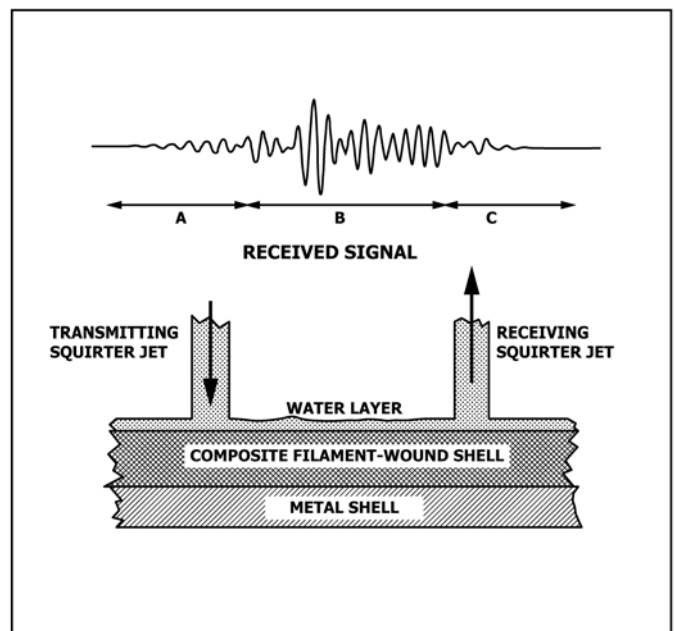

FIG. 4 Representation of Different Portions of Received Signal and Acoustic Paths from Transmitting to Receiving Water Jet Probes; Parts A and B of Received Signal Relate to Composite Shell and Are Gated for Analysis, and Part C is from Water Layer and is Discarded

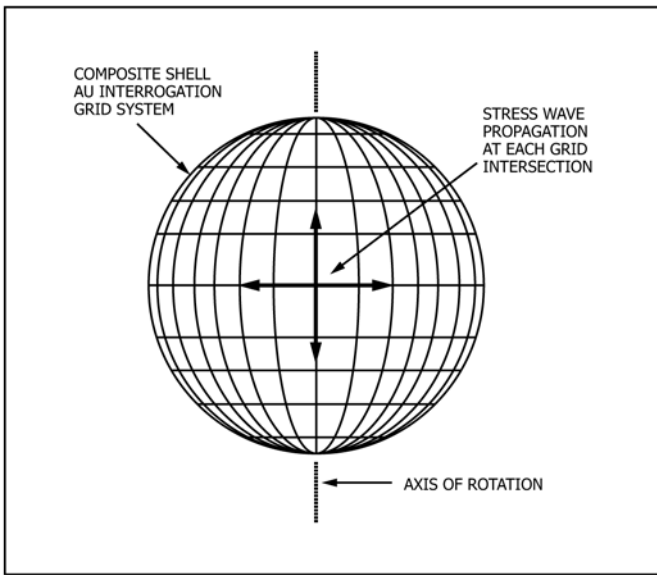

FIG. 5 Example of Composite Shell Grid System for Interrogation Using Squirter Jet AU Probes; At Each Grid Intersection, AU Stress Wave Propagation is Measured in at Least Two Mutually Orthogonal Directions, for Example, Latitudinally and Longitudinally for Spheres and Circumferentially and Axially for Cylinders

AU SWF, and these are discretionary. The rms voltage is recommended as a practical quantification of the AU SWF.

9.4.1 Store the rms AU voltage values on disk along with the corresponding location on the shell.

9.4.2 Set up a scheme for mapping the rms AU voltage values on a digital video image of the composite shell.

9.4.3 It may be necessary to normalize AU signal variations caused by shell thickness variations due to different numbers of filament-wound layers in different zones (Fig. 2).

9.4.3.1 This should be accomplished by normalizing the rms AU signal for each latitude or zone of the composite shell.

9.4.3.2 As an example, take 80 readings around each major latitude and determine the maximum rms AU value for each latitude.

9.4.3.3 Normalize the readings at each latitude with respect to the maximum rms AU value for that latitude.

10. Reporting Requirements

10.1 Tabulate and map the rms AU voltages on a three-dimensional representation or flat (Cartesian) projection of the composite shell surface.

10.1.1 Classify the rms AU voltages into a small number of distinct categorical levels (for example, eight levels), with each represented by a particular greytone or color, and present them as a printed image or set of images.

10.1.2 Rank each successive categorical value so that it represents a jump in the material condition, for example, from

fully acceptable to unacceptable or some other appropriate interpretational ranking.

10.1.3 Tabulate the percent of the total surface area represented by each of the categories (or eight levels), and display them as a greytone or color bar alongside the printed image of the composite shell.

10.1.4 If other than the rms voltage is used for quantifying the AU SWF, indicate the alternative method used.

10.2 Describe the Pressure Vessel:

10.2.1 Material and pertinent dimensions of the inner shell.

10.2.2 Material, pertinent dimensions, and unique features of the composite shell.

10.2.2.1 Specifications of the fiber (filament) and matrix material;

10.2.2.2 Winding pattern, number of layers, and fiber orientations;

10.2.2.3 Roughness, texture, coating, or other surface features;

10.2.2.4 Original, as-manufactured condition, if new; and

10.2.2.5 Nature of possible service damage/degradation, if used.

10.3 Describe the Apparatus, Probe Fixture, Instrumentation, and Reference Vessel/Shell:

10.3.1 Overall dimensions of the apparatus;

10.3.2 Specifications of the ultrasonic probes (size, center frequency, and so forth);

10.3.3 Pertinent instrumentation settings (for pulser-receiver, oscilloscope, and so forth);

10.3.4 Description of grid system and directions used for scanning/examination; and

10.3.5 Description of reference vessel/shell, if used for comparison/standardization.

11. Remarks

11.1 It is recommended that filament-wound structures for instrument standardization and reference be fabricated. These structures should represent optimum, intermediate, and variously defective structures. Creating reference vessels for instrument standardization becomes a problem of identifying the most successful production conditions and the best resultant material samples.

11.2 This practice should be used to establish feedback to process development and control. The AU monitoring of the filament-winding process should help optimize the results by providing quantitative comparisons and a check on processing parameters such as fiber tow impregnation, spacing, tension, heating, and the like.

12. Keywords

12.1 acoustic emission; acousto-ultrasonics; fiber reinforced composites; filament-wound pressure vessels; nondestructive evaluation; nondestructive testing

SUMMARY OF CHANGES

Committee E07 has identified the location of selected changes to this standard since the last issue (E1736–10) that may impact the use of this standard.

(1) Added “Summary of Changes.”

(2) Added ISO 9712 to new subsection 2.4 and to 6.2.

ASTM International takes no position respecting the validity of any patent rights asserted in connection with any item mentioned in this standard. Users of this standard are expressly advised that determination of the validity of any such patent rights, and the risk of infringement of such rights, are entirely their own responsibility.

This standard is subject to revision at any time by the responsible technical committee and must be reviewed every five years and if not revised, either reapproved or withdrawn. Your comments are invited either for revision of this standard or for additional standards and should be addressed to ASTM International Headquarters. Your comments will receive careful consideration at a meeting of the responsible technical committee, which you may attend. If you feel that your comments have not received a fair hearing you should make your views known to the ASTM Committee on Standards, at the address shown below.

This standard is copyrighted by ASTM International, 100 Barr Harbor Drive, PO Box C700, West Conshohocken, PA 19428-2959, United States. Individual reprints (single or multiple copies) of this standard may be obtained by contacting ASTM at the above address or at 610-832-9585 (phone), 610-832-9555 (fax), or service@astm.org (e-mail); or through the ASTM website (www.astm.org). Permission rights to photocopy the standard may also be secured from the Copyright Clearance Center, 222 Rosewood Drive, Danvers, MA 01923, Tel: (978) 646-2600; <http://www.copyright.com/>