



Standard Specification for Miniature Thermocouple Connectors¹

This standard is issued under the fixed designation E1684/E1684M; the number immediately following the designation indicates the year of original adoption or, in the case of revision, the year of last revision. A number in parentheses indicates the year of last reapproval. A superscript epsilon (ϵ) indicates an editorial change since the last revision or reapproval.

1. Scope

1.1 This specification covers separable single-circuit miniature thermocouple connectors with two flat pins. Connectors covered by this specification must be rated for continuous use to at least 300°F (150°C), but they may optionally be rated to a higher temperature.

1.2 This specification does not cover multiple-circuit connectors, multi-pin connectors, standard size connectors, or connectors intended primarily for panel mounting. High-temperature connectors (for example, those designed for continuous use at temperatures significantly above approximately 500°F [260°C]) are not intended to be covered by this specification.

1.3 The values stated in either SI units or inch-pound units are to be regarded separately as standard. The values stated in brackets are not conversions to the values they succeed and therefore shall be used independently of the preceding values. The values given in parentheses are conversions of the values they succeed. Combining values from the two systems may result in non-conformance with the standard.

1.4 The plug and jack may be ordered separately but many of the connector characteristics (see [Table 1](#)) are qualified as a mated pair. The requirements in this standard are applicable for the connector pair supplied by the same manufacturer.

1.5 The following precautionary statement pertains only to the Test Methods portion, Section 9, of this specification: *This standard does not purport to address all of the safety concerns, if any, associated with its use. It is the responsibility of the user of this standard to establish appropriate safety and health practices and determine the applicability of regulatory limitations prior to use.*

2. Referenced Documents

2.1 The following documents of the latest issue form a part of this specification to the extent referenced herein. In case of

¹ This specification is under the jurisdiction of ASTM Committee E20 on Temperature Measurement and is the direct responsibility of Subcommittee E20.04 on Thermocouples.

Current edition approved Dec. 1, 2015. Published January 2016. Originally approved in 1995. Last previous edition approved in 2010 as E1684 – 10. DOI: 10.1520/E1684-15.

conflict between this specification and another referenced document, this specification shall take precedence.

2.2 ASTM Standards:²

- E230/E230M Specification and Temperature-Electromotive Force (emf) Tables for Standardized Thermocouples
- E344 Terminology Relating to Thermometry and Hydrometry
- E2820 Test Method for Evaluating Thermal EMF Properties of Base-Metal Thermocouple Connectors

3. Terminology

3.1 *Definitions*—The definitions given in Terminology E344 shall apply.

3.2 Definitions of Terms Specific to This Standard:

3.2.1 *connector pair, n*—assembly consisting of a plug and a jack, each having both positive and negative inserts, that will connect two parts of an electrical circuit and provide a means of physically disconnecting the two parts without the use of a tool.

3.2.2 *contact insert, n*—metallic conductor assemblies that, when installed in connector bodies, provide connections between two parts of an electrical circuit. Plug connectors will contain projecting prong contacts, while jack connectors will contain recessed socket or receptacle contacts.

3.2.3 *service life, n*—period of time over which a connector assembly can be put to use and retain all physical and thermoelectric properties.

3.2.4 *test difference, n*—thermoelectric emf value attributable to mated connectors observed by the test procedure of this specification.

4. Significance and Use

4.1 The widespread use of thermocouple connectors requires standardization of mating dimensions and performance characteristics.

4.2 This specification describes miniature thermocouple connector dimensions and capabilities and includes test procedures suitable for evaluating the performance of a particular

² For referenced ASTM standards, visit the ASTM website, www.astm.org, or contact ASTM Customer Service at service@astm.org. For *Annual Book of ASTM Standards* volume information, refer to the standard's Document Summary page on the ASTM website.

TABLE 1 Ratings

Characteristic	Min	Max	Requirement	Test Procedure
Operating temperature	0°F [-18°C]	300°F [150°C]	7.1.2	9.7
Contact resistance (each leg)	...	0.04 Ω	7.2.6	9.2
Insulation resistance at room temperature	10 ⁷ Ω	...	7.3.4	9.4
Insulation resistance at 300 °F (150 °C)	10 ⁶ Ω	...	7.3.4	9.4
Thermal gradient test difference	...	±2°F [±1.1°C]	7.2.7	9.3
Repeated cycles	25	...	7.2.4	9.6
Service life	5000 h	...	7.3.5	9.7
Disengagement force	8 ozf [2.2 N]	...	7.2.3	9.5

specimen or design. The tests described are not intended for routine inspection or rapid testing of large groups of connectors or for quality control purposes.

5. Classification

5.1 Plugs or Jacks:

5.1.1 Connectors shall be constructed as either plugs or jacks, and these two forms shall be designed to connect with each other.

5.1.2 Plug connectors shall have two external prong contacts of different dimensions to prevent improper mating. The negative prong shall be the wider, as indicated in Table 2 and Fig. 1.

5.1.3 Jack connectors shall have two internal socket contacts sized and spaced to receive and accommodate the prong contacts of the mating plug. Jack connectors shall also include a means of producing and maintaining sufficient contact pressure to meet all the other requirements of this specification.

5.2 ANSI/ASTM Type:

5.2.1 Connectors shall be produced in versions to match each of the standardized ANSI/ASTM thermocouple types as given in Table 3.

5.2.2 The insert materials of each plug and jack shall have thermoelectric properties conforming to the nominal characteristics of the corresponding thermocouple type as given in Specification E230/E230M over the operating temperature range specified in Table 1.

5.2.3 Calibration conformance and gradient testing is not applicable to Type B thermoelectrically neutral (Cu/Cu) connectors.

6. Ordering Information

6.1 Orders for connectors under this specification shall include the following:

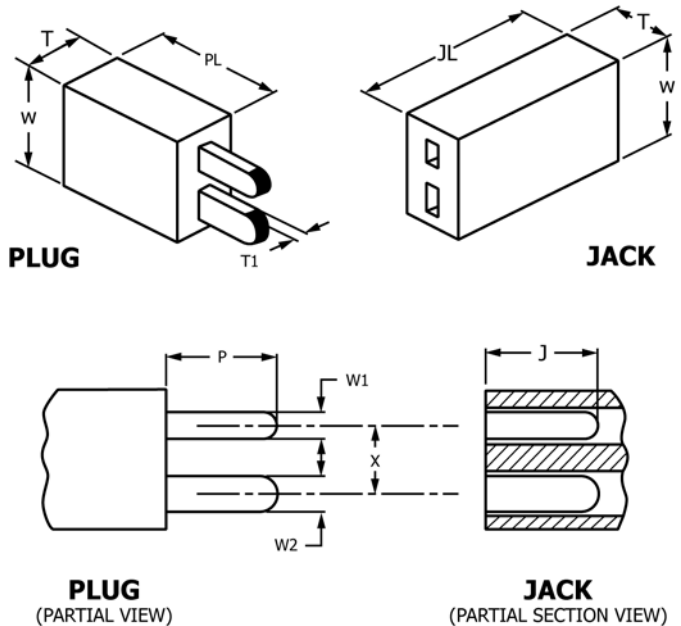

FIG. 1 Miniature Thermocouple Connector Dimensions (see Table 2)

TABLE 3 Identification

ANSI/ASTM Type	Body Color Coding
T	blue
J	black
E	purple
K	yellow
N	orange
R or S	green
B (Cu/Cu) ^A	white
C	red

^A Uncompensated (Cu/Cu) connectors are customarily used with Type B thermocouples.

TABLE 2 Dimensions

Dimension	Symbol ^A	Minimum Size, in. (mm)	Maximum Size, in. (mm)
Plug body length	PL	...	0.788 (20.00)
Jack body length	JL	...	1.069 (27.13)
Body width	W	...	0.635 (16.10)
Body thickness	T	...	0.385 (9.78)
Length of prong	P	0.406 (10.31)	0.515 (13.10)
Depth of socket	J	0.515 (13.10)	...
Prong spacing	X	0.307 (7.80)	0.317 (8.05)
Positive pin width	W1	0.090 (2.28)	0.098 (2.49)
Negative pin width	W2	0.121 (3.07)	0.129 (3.27)
Pin thickness	T1	0.030 (0.73)	0.034 (0.86)

^A Symbol reference corresponds to Fig. 1.

- 6.1.1 Quantity of plugs or jacks (specify which);
- 6.1.2 ANSI/ASTM thermocouple type (see Table 3);
- 6.1.3 Any optional accessories that may be required, such as those listed in 7.4.3;
- 6.1.4 Special testing requirements; and
- 6.1.5 Requirements for certificates of conformance to the specifications or reports of the results of any required testing.

7. Materials and Manufacture

7.1 Body:

7.1.1 The dimensions of the connector bodies shall fall within the limits given in Table 2.

7.1.2 The connector body shall be made of an insulating material capable of continuous use at any temperature between 0°F [-18°C] and 300°F [150°C] for the service life given in **Table 1**, without losing its ability to conform to this specification.

7.1.3 The connector bodies shall be color-coded in accordance with **Table 3** to provide rapid and permanent identification of the thermocouple calibration with which they are designed to be used. Each plug and jack shall be permanently marked with a symbol or symbols to identify positive and negative conductor inserts. All connectors shall bear the supplier's name or other means of source identification, unless otherwise specified in the purchasing documents.

7.1.4 An insulating barrier shall be incorporated into each connector body to prevent inadvertent contact between thermoelements or wires.

7.2 Inserts:

7.2.1 Contact inserts shall be fabricated of materials that meet the requirements of **5.2**

7.2.2 The inside width, thickness, and depth of the jack connector shall be such as to receive the corresponding plug's prong smoothly and easily when inserted.

7.2.3 The force required for complete disengagement shall conform to the requirements of **Table 1**.

7.2.4 The connector pair shall be capable of repeated insertion and withdrawal cycles as given in **Table 1** without losing the ability to conform to the requirements of this specification.

7.2.5 The dimensions and locations of the inserts in the connector body shall fall within the limits given in **Table 2**.

7.2.6 The contact resistance between the assembled plug and jack shall conform to the requirements of **Table 1**.

7.2.7 The connector pair shall be capable of passing the thermal gradient test specified in **Table 1**.

7.3 Construction and Assembly:

7.3.1 Wire attachment shall be by means of a screw or clamp suitable for use with wire diameters from 30 AWG (0.01 in. [0.25 mm] in diameter) to 20 AWG (0.032 in. [0.8 mm] in diameter).

7.3.2 Contact inserts and wire attaching parts shall be held captive to one of the body parts.

7.3.3 Connections and final closures of the connector shall be accomplished with simple hand tools such as screwdrivers, wrenches, or pliers.

7.3.4 The assembled connector shall be capable of passing the insulation resistance requirements listed in **Table 1** at the temperatures listed.

7.3.5 The materials and construction used in the connector shall be such that the connector will meet all of the specified requirements for the service life interval listed in **Table 1**.

7.4 Optional Accessories:

7.4.1 Connector accessories are not covered by this specification and may be unique to a manufacturer's specific design.

7.4.2 All required optional accessories are to be specified separately from the connectors.

7.4.3 The following is a partial list of useful accessory items:

7.4.3.1 Cable clamping devices for attaching flexible cables;

7.4.3.2 Clamps for rigid tubing and sheaths in a range of diameters whose conductor sizes are within the range specified in **7.3.1**;

7.4.3.3 Elastomeric boots to seal connector assemblies against moisture in service;

7.4.3.4 Safety clamps or other devices to prevent inadvertent separation of connectors under conditions of severe vibration;

7.4.3.5 Flat washers for use under wire attachment screw heads as an aid in the retention of the wires.

7.4.4 Some suppliers may not offer all the above items, while others may offer additional items. Supplier catalogs and literature should be consulted for details.

8. Physical Properties

8.1 The physical size of connectors conforming to this specification shall fall within the limits given in **Table 2** for all dimensions indicated in that table. All other dimensions and all details of construction shall be determined by the manufacturer's specific design.

9. Test Methods

9.1 Test Frequency:

9.1.1 The tests listed in **Table 4** shall be conducted as either Qualification or Production tests.

9.1.2 Tests listed as "Qualification" tests shall be initially performed by the manufacturer to demonstrate conformance to this specification, and then periodically, as determined by the manufacturer, to verify that the connectors continue to meet the requirements of this specification.

9.2 Contact Resistance Test:

9.2.1 The contact resistance of the positive leg of a mated connector pair shall be measured at room temperature using a four wire ohm measurement as shown in **Fig. 2**. The ohm-meter shall have a resolution of at least 0.001 ohms and preferably an internal function for DC offset compensation. If the ohm-meter does not have DC offset compensation the procedure shall be repeated on the same leg of the mated connector pair but with reversed polarity. The average of the two measured resistance values shall be taken as the contact resistance value.

9.2.2 The entire procedure of **9.2.1** is then repeated for the other half (the negative leg) of the same mated connector pair.

9.2.3 The contact resistance value for each leg shall be within the limit given in **Table 1**.

9.2.4 Alternate test methods may be used if agreeable to both the supplier and the purchaser. In such event, the test method to be used shall be identified.

TABLE 4 Tests

Paragraph Number	Test Description	Type
9.2	Contact Resistance	Qualification
9.3	Thermal Gradient	Qualification
9.4	Insulation Resistance	Qualification
9.5	Disengagement Force	Qualification
9.6	Repeated Cycles	Qualification
9.7	Service Life	Qualification

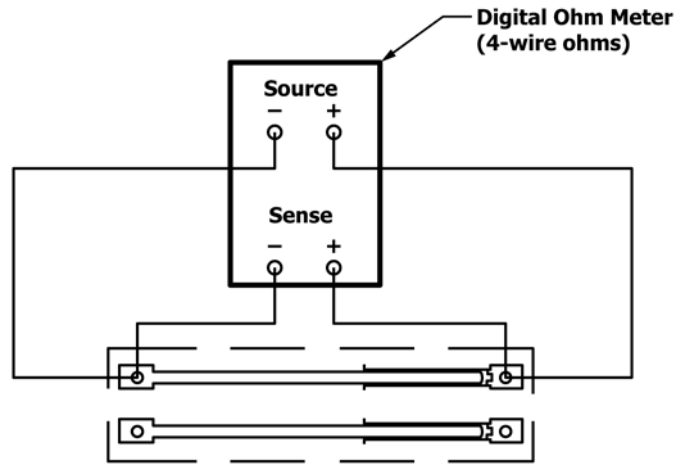

FIG. 2 Contact Resistance Test

9.3 Thermal Gradient Test:

9.3.1 The Thermal Gradient Test shall be conducted in accordance with Test Method E2820 Method 1 (dry-well furnace) under Condition A (150°F [65°C]). The measured test difference shall not exceed the value given in Table 1 for qualification under this specification.

9.4 Insulation Resistance Test:

9.4.1 Insulation resistance between legs shall be measured with a megohm meter using a voltage between 25 and 100 VDC. The measured resistance shall not be less than the value given in Table 1 when tested at any temperature within the operating temperature range (see Fig. 3).

9.4.2 The insulation resistance between each leg and any other exposed metallic part or electrically conducting portion of a thermocouple connector assembly, including fasteners, shall not be less than the value given in Table 1 when tested in a manner similar to 9.4.1.

9.5 Disengagement Force Test:

9.5.1 Measure the disengagement force by attaching a force meter to the connector plug, clamping the connector jack and measuring the amount of force required to completely disconnect the two components (see Fig. 4).

9.6 Repeated Cycles Test:

9.6.1 When inserted and withdrawn the number of cycles indicated in Table 1, the disengagement force shall not be less than the value specified in Table 1.

9.7 Service Life Test:

9.7.1 Expose the connector plug and jack to the maximum temperature specified in Table 1 for the specified service life. After exposure, the connectors shall pass the disengagement force, contact resistance, insulation resistance and thermal gradient tests specified in Section 9 and Table 1.

10. Rejection

10.1 Material that fails to conform to the requirements of this specification may be rejected.

11. Keywords

11.1 connector; contact inserts; jacks; miniature connector; plug; thermocouple; thermocouple connector

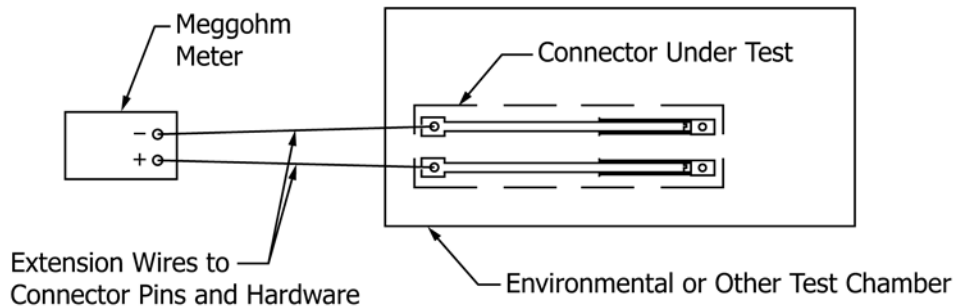

FIG. 3 Insulation Resistance Test

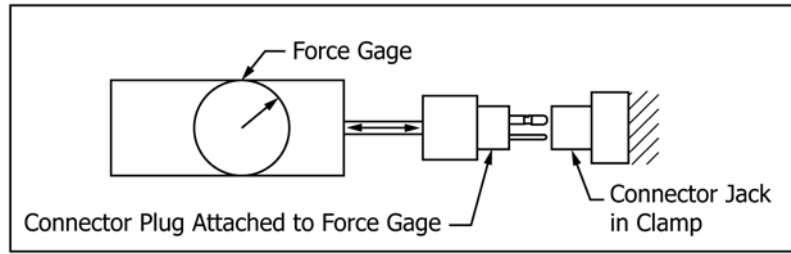

FIG. 4 Disengagement Force Test

ASTM International takes no position respecting the validity of any patent rights asserted in connection with any item mentioned in this standard. Users of this standard are expressly advised that determination of the validity of any such patent rights, and the risk of infringement of such rights, are entirely their own responsibility.

This standard is subject to revision at any time by the responsible technical committee and must be reviewed every five years and if not revised, either reapproved or withdrawn. Your comments are invited either for revision of this standard or for additional standards and should be addressed to ASTM International Headquarters. Your comments will receive careful consideration at a meeting of the responsible technical committee, which you may attend. If you feel that your comments have not received a fair hearing you should make your views known to the ASTM Committee on Standards, at the address shown below.

This standard is copyrighted by ASTM International, 100 Barr Harbor Drive, PO Box C700, West Conshohocken, PA 19428-2959, United States. Individual reprints (single or multiple copies) of this standard may be obtained by contacting ASTM at the above address or at 610-832-9585 (phone), 610-832-9555 (fax), or service@astm.org (e-mail); or through the ASTM website (www.astm.org). Permission rights to photocopy the standard may also be secured from the Copyright Clearance Center, 222 Rosewood Drive, Danvers, MA 01923, Tel: (978) 646-2600; http://www.copyright.com/