



# Standard Test Method for Water Penetration of Exterior Metal Roof Panel Systems by Uniform Static Air Pressure Difference<sup>1</sup>

This standard is issued under the fixed designation E1646; the number immediately following the designation indicates the year of original adoption or, in the case of revision, the year of last revision. A number in parentheses indicates the year of last reapproval. A superscript epsilon ( $\epsilon$ ) indicates an editorial change since the last revision or reapproval.

## 1. Scope

1.1 This test method covers the determination of the resistance of exterior metal roof panel systems to water penetration when water is applied to the outdoor face simultaneously with a static air pressure at the outdoor face higher than the pressure at the indoor face, that is, positive pressure. This test method is a specialized adaption of Test Method E331.

1.2 This test method is applicable to any roof area and is intended to measure only the water penetration associated with the field of roof including panel side laps and structural connections. It does not include leakage at openings or perimeter or any other details.

1.3 This test method is limited to specimens in which the side seams and attachments are clearly visible and in which the source of leakage is readily determined. Composite systems in which the source cannot be readily determined are outside the scope of this test method.

1.4 The proper use of this test method requires a knowledge of the principles of pressure and flow measurement.

1.5 The values stated in inch-pound units are to be regarded as the standard. The values given in parentheses are for information only and may be approximate.

1.6 The text of this test method references notes and footnotes excluding tables and figures, which provide explanatory material. These notes and footnotes shall not be considered as requirements of the test method.

1.7 *This standard does not purport to address all of the safety concerns, if any, associated with its use. It is the responsibility of the user of this standard to establish appropriate safety and health practices and determine the applicability of regulatory limitations prior to use.* For specific hazard statements, see 7.1.

<sup>1</sup> This test method is under the jurisdiction of ASTM Committee E06 on Performance of Buildings and is the direct responsibility of Subcommittee E06.57 on Performance of Metal Roof Systems.

Current edition approved March 1, 2011. Published March 2011. Originally approved in 1995. Last previous edition approved in 2003 as E1646 – 95 (2003). DOI: 10.1520/E1646-95R11.

## 2. Referenced Documents

### 2.1 ASTM Standards:<sup>2</sup>

E331 Test Method for Water Penetration of Exterior Windows, Skylights, Doors, and Curtain Walls by Uniform Static Air Pressure Difference

E631 Terminology of Building Constructions

E1680 Test Method for Rate of Air Leakage Through Exterior Metal Roof Panel Systems

E1592 Test Method for Structural Performance of Sheet Metal Roof and Siding Systems by Uniform Static Air Pressure Difference

### 2.2 Other Standards:

AAMA 501 Methods of Test for Metal Curtain Walls<sup>3</sup>

## 3. Terminology

3.1 *Definitions*—For definitions of general terms relating to building construction used in this test method, see Terminology E631.

### 3.2 Definitions of Terms Specific to This Standard:

3.2.1 *specimen*—the entire assembled unit submitted for test as described in Section 8.

3.2.2 *test pressure difference*—the specified difference in static air pressure across the assembled and fixed specimen expressed as pounds-force per square foot (newtons per square metre (pascals)).

3.2.3 *water leakage*—penetration of water onto the exposed inside surface of the test specimen under specified conditions of air pressure difference across the specimen during a 15-min test period. Water penetration at or around end dams or side rails is not leakage; end dams and side rails are installed to cause and control ponding over the panels and to support the panels. They are not part of the roof.

<sup>2</sup> For referenced ASTM standards, visit the ASTM website, [www.astm.org](http://www.astm.org), or contact ASTM Customer Service at [service@astm.org](mailto:service@astm.org). For *Annual Book of ASTM Standards* volume information, refer to the standard's Document Summary page on the ASTM website.

<sup>3</sup> Available from Architectural Aluminum Manufacturers Association (AAMA), 1827 Walden Office Square, Suite 550, Schaumburg, IL 60173, <http://www.aamanet.org>.

## 4. Summary of Test Method

4.1 This test method consists of sealing and fixing the test specimen into or against one face of a test chamber, supplying air to or exhausting air from the chamber at the rate required to maintain the test pressure difference across the specimen, while spraying water onto the outdoor face of the specimen at the required rate and observing any water leakage.

## 5. Significance and Use

5.1 This test method is a standard procedure for determining the resistance to water penetration under uniform positive static air pressure differences, and simulates wind driven rain imposed on sidelaps and rain that is free to drain while building a water head as it flows. The slope of the roof is significant. These factors shall be fully considered prior to specifying the test pressure difference.

NOTE 1—In applying the results of tests by this method, note that the performance of a roof or its components, or both, may be a function of proper installation and adjustment. In service, the performance also depends on the rigidity of supporting construction, roof slope, and on the resistance of components to deterioration by various causes: corrosive atmosphere, aging, ice, vibration, thermal expansion and contraction, etc. It is difficult to simulate the identical complex wetting conditions that can be encountered in service, including large wind-blown water drops, increasing water drop impact pressures with increasing wind velocity, and lateral or upward moving air and water. Some designs are more sensitive than others to this upward moving water.

NOTE 2—This is a test procedure. It is the responsibility of the specifying agency to determine the specimen construction, size, and test pressures after considering the method's guidelines. Practical considerations suggest that every combination of panel thickness, span, and design load need not be tested in order to substantiate product performance.

NOTE 3—This test method shall not, by itself, be relied upon to form conclusions about overall water penetration through metal roofs. A roof contains many details. Although prescribed modifications are outside the scope of this test method, an experienced testing engineer is able to use the principles presented in this test method and generate significant data by isolating specific details and measuring leakage.

## 6. Apparatus

6.1 The description of apparatus in this section is general in nature, and any arrangement of equipment capable of performing the test procedure within the allowable tolerances is permitted.

6.2 *Major Components (see Fig. 1):*

6.2.1 *Test Chamber*—A test chamber or box with either an opening, a removable mounting panel, or one open face in which or against which the specimen is installed and sealed. The specimen shall be installed horizontally. Chamber design shall not allow run-off from the test chamber to drain onto the test specimen. At least one static pressure tap shall be provided to measure the chamber pressure and shall be so located that the reading is unaffected by the velocity of the air supply to or from the chamber. The air supply opening into the chamber shall be arranged so that the air does not impinge directly on the test specimen with any significant velocity. When required, a means of access shall be provided into the chamber to facilitate adjustments and observations after the specimen has been installed.

NOTE 4—Uniform ponding is essential to this test method—refer to 5.1. For this reason the specimen slope must be horizontal, and the overflow

devices described in 8.3 are required to control ponding. Chamber run-off that drains onto the specimen is not allowed so that the accuracy and uniformity of the metered flow rate described in 6.2.4 is not compromised.

6.2.2 *Air System*—A controllable blower, compressed air supply, exhaust system, or reversible blower designed to provide the required maximum air-pressure difference across the specimen. The system must provide essentially constant airflow at a fixed pressure for the required test period and be capable of maintaining positive and negative pressures.

6.2.3 *Pressure-Measuring Apparatus*—A device to measure the test pressure difference within a tolerance of  $\pm 2\%$ . The device must measure positive and negative pressures.

6.2.4 *Water-Spray System*—The water-spray system shall deliver water uniformly against the exterior surface of the test specimen at a minimum rate of 5.0 U.S. gal/ft<sup>2</sup> per h or 8 in./h (3.4 L/m<sup>2</sup> per min).

6.2.4.1 The water-spray system shall have nozzles spaced on a uniform grid, located at a uniform distance approximately 12 in. (0.3 m) above the test specimen, and be adjustable to provide the specified quantity of water in such a manner as to wet the test specimen uniformly and to wet those areas vulnerable to water leakage. The spray must be directed at all overlapping side seams with the stream centerline approximately 20° off vertical (see Fig. 1). If additional nozzles are required to provide uniformity of water spray at the edge of the test specimen, they shall be equally spaced around the entire spray grid.

## 7. Hazards

7.1 **Warning**—Glass breakage and specimen failure do not normally occur at the small pressure differences applied in this test. Larger or excessive pressure differences occur during preload or due to error in operation or when the apparatus is used for other purposes such as structural testing; therefore, exercise adequate precautions to protect personnel.

## 8. Test Specimen

8.1 Roof test specimens shall be of sufficient size to determine the performance of all typical parts of the roof system. For roofs constructed with prefabricated or preformed units or panels, the specimen width shall be equivalent to or greater than the width of three typical units plus the side rail supporting elements at each edge. The specimen shall contain at least three assembled side lap seams; this allows partial width units. The specimen width shall be sufficient to provide loading on at least one typical unit (see Fig. 1). The specimen shall be of sufficient length to develop a multispan condition unless the panel is used only in single span applications. If two spans are used, they shall be unequal, with the shorter being 75 % of the longer. One panel end lap is optional but shall not be used if the test will be run in tandem with Test Method E1680. However, one end lap is allowed if the specifying authority adopts the option at Test Method E1680.

NOTE 5—The unbalanced span criterion more closely simulates multi-span panel deflection curvature. This works the panel sidelap while minimizing specimen length.

8.1.1 All parts of the roof test specimen shall be full size, using the same materials, details, and methods of construction and anchorage as used on actual buildings.

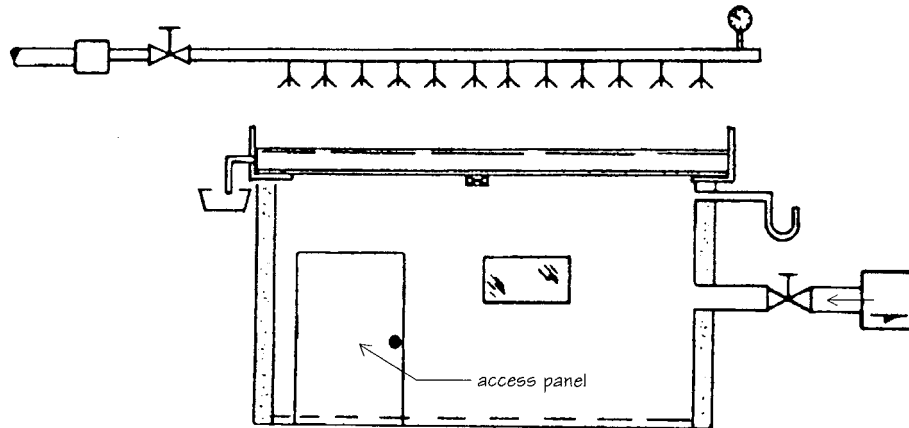
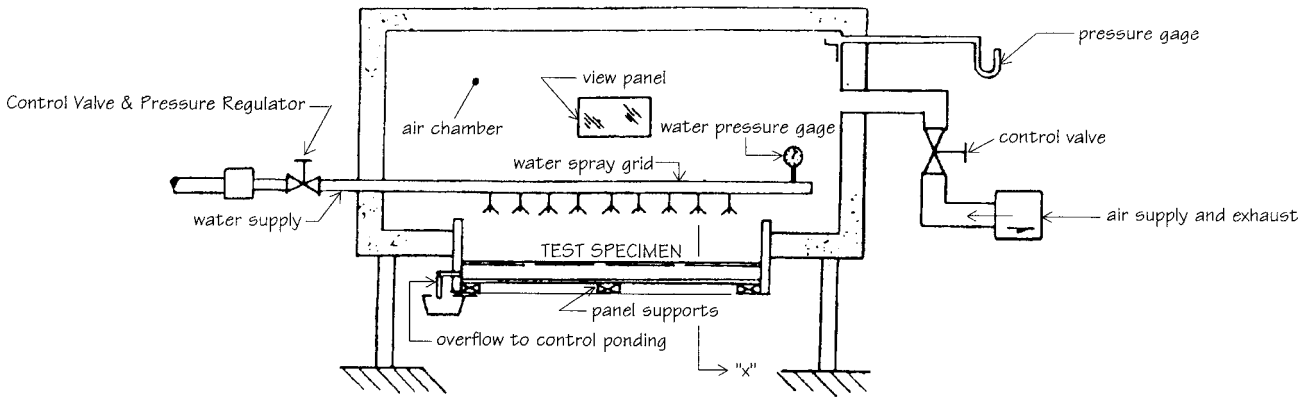

Alternate

Alternate preferred if dynamic test will be performed on same specimen. When a negative pressure system is used to create positive pressure on the specimen, the water-spray grid shall be located outside the chamber.

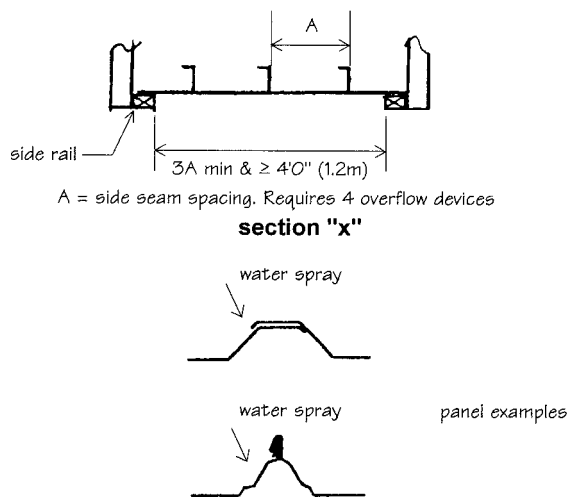

FIG. 1 General Arrangement of Water Leakage Apparatus Positive Chamber System

8.1.2 Condition of structural support shall be simulated as accurately as possible. If the roof system accommodates thermal expansion parallel to the panel, this detail must be included in the test specimen, and the interior support must be able to slide parallel to the panel or its attachment or both.

8.2 If insulation is an optional component of the roof system, it shall not be included in the test specimen.

8.2.1 If only one specimen is to be tested, the specifying authority determines the selection.

NOTE 6—It should be recognized that performance is likely to be a function of size, geometry, and stiffness. Therefore, select specimens covering the range of sizes to be used in a building. In general, the largest size and least stiff of a particular design, type, construction, and configuration should be tested (see Note 2 for related commentary).

8.3 Overflow devices shall be provided to ensure that water ponds at least 1/2 in. (13 mm) but no more than 3/4 in. (20 mm) above the panel bottom between each major flute while the specimen is subjected to the specified flow.

**9. Calibration**

9.1 The ability of the test apparatus to meet the requirements of 6.2.4.1 shall be checked by using a catch box, the open face of which shall be located at the position of the face of the test specimen. The calibration device is illustrated in Fig. 2. The catch box shall be designed to receive only water impinging on the plane of the test specimen face and to exclude all run-off water from above. The box shall be 24 in. (610 mm) square and divided into four areas each 12 in. (305 mm) square. Use a cover approximately 30 in. (760 mm) square to prevent water from entering the calibration box before and after the timed observation interval. The water impinging on each area

shall be captured separately. A spray that provides at least 20 gal/h (1.26 L/min) total for the four areas and not less than 4 gal/h (0.25 L/min) nor more than 10 gal/h (0.63 L/min) in any one square shall be acceptable.

9.1.1 The water-spray system shall be calibrated at all corners and, if no overlapping occurs, at the quarter and mid-points of the horizontal center line (of the spray system). If a number of identical, contiguous, modular spray systems are used, only one module is required to be calibrated. The system shall be calibrated with the catch boxes at a distance within ±2 in. (50 mm) of the required test specimen location relative to the nozzle. Recalibration shall be at intervals necessary in the judgment of the testing agency but not longer than 6 months.

**10. Information Required**

10.1 The test-pressure difference or differences at which water penetration is to be determined, unless otherwise specified, shall be 2.86 lbf/ft<sup>2</sup> (137 Pa) for roof applications less than or equal to 30° from horizontal. Unless otherwise specified, this test-pressure shall be 20 % of the positive design wind pressure but not less than 6.24 lbf/ft<sup>2</sup> (300 Pa) for roof applications steeper than 30° from horizontal. The test pressure shall not exceed 12 lbf/ft<sup>2</sup> (575 Pa).

NOTE 7—This commentary is included to assist the specifier in the selection of test pressures. This test method is consistent with the default test-pressure in Test Method E331 and the recommendations in AAMA Methods 501. This test method considers that although neither is tolerable, water penetration at roofs is generally even less acceptable than at walls. However, for shallow roofs, the test pressure requirement is buffered since these roofs rarely see large positive pressures unless the resultant pressure is caused by building openings. The default test pressure in Test Method E331 has been adapted for low sloped roofs. Positive pressures

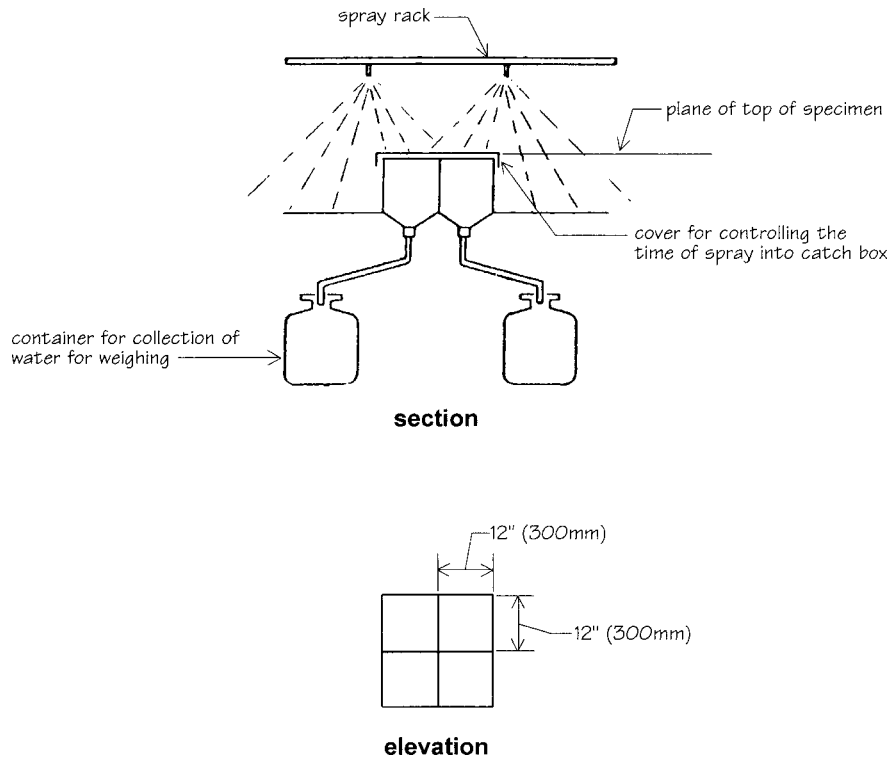

FIG. 2 Catch Box for Calibrating Water-Spray System



are more probable at steeper slopes. Most model codes recognize this, and 30° from horizontal is generally selected as the slope above which positive external wind pressures must be considered. This test method selects the 30° slope as its break point and adopts the AAMA 501 test pressure recommendations over the steeper slope range. If a product is only used on slopes greater than 60° from horizontal, consider testing per Test Method E331 while recognizing that steep roofs are subjected to positive and negative wind loads and that the preload criteria make this test method meaningful at the steepest slopes. This test method's default test-pressures recognize that most rains of any duration are associated with lower velocity winds; this does not imply that water penetration associated with hurricane driven rains would be acceptable. This test method provides a valid means to compare systems. Do not exceed the default conditions unless unusual site conditions exist or "value added" benefits are required and have been considered.

10.2 The preload test pressure differences—positive and negative—are to be specified. The positive preload pressure difference shall be the greater of 75 % of the building live load or 50 % of the building design positive wind pressure difference. The positive test pressure shall be greater than or equal to 15 lbf/ft<sup>2</sup> (720 Pa). The negative preload pressure difference shall be 50 % of the design wind uplift pressure difference.

NOTE 8—This is not a structural adequacy test, for example, among others, Test Method E1592 is used for roofs. The preload test pressure requirement of 11.3 and the thermal movement requirement of 11.2 represent significant departures from Test Method E331. The requirements are included to work the side seams prior to imposing test pressures. The requirements illustrate a greater concern over roof leaks plus the greater panel lengths and consequent expansion in roofs. The recommended design pressures and number of applications do not overly tax the capacities of most test apparatus nor the time duration of tests as they simulate service life by repetitively preloading to approximately 75 % of the design snow load or design wind velocity. If the design pressures vary from roof zone to roof zone on a particular project, select the wind pressure of the central field zone of the largest area as the building design pressure for the test. For balanced designs of equal stiffness throughout a roof, the selection of the central field zone allows adequate working of the side seams and is representative of the entire roof. Even when stiffness conditions are not balanced throughout the roof, the recommended criteria work the seams, minimize the number of tests per project, and allow comparisons of alternate systems.

10.3 If the roof system accommodates thermal expansion parallel to the panel, the design differential movement capacity relative to purlin top flanges must be provided and specified.

10.4 The typical panel span on the actual building or the controlling published allowable span at the specified design pressures shall be determined and used in the specimen construction of 8.1 (see Note 2, Note 7, and Note 8 for further commentary).

## 11. Procedure

11.1 Remove any sealing material or construction that is not normally a part of a typical panel assembly as installed in the field of a building. Note the field sealant type, geometry, and location. Fit the specimen frame into or against the chamber opening with the outdoor side of the specimen facing both the high pressure side of the chamber and the water spray and in such a manner that no panel joints or nozzle openings are obstructed. Seal the outer perimeter of the specimen frame to the chamber wall and seal at no other points. The perimeter seals between the panels and the specimen frame do not have to duplicate actual building perimeter details. Restrain the

specimen frame work to develop the chamber seal and to resist preload and test pressures.

NOTE 9—Nonhardening mastic compounds or pressure sensitive tape can be used effectively to seal the test specimen to the chamber opening, to seal the access door to the chamber, and to achieve airtightness in the construction of the chamber. These materials can be used to seal a separate mounting panel to the chamber. Rubber gaskets with clamping devices may also be used for this purpose, provided that the gasket is highly flexible and has a small contact edge.

11.2 If the roof accommodates thermal movement parallel to the panel, slide the central support to traverse 75 % of the specified cycle of 10.3. The support shape shall be chosen, and the sliding force shall be applied to avoid unusual twisting of the supports. The initial location of all thermal relief features shall be mid-range. Repeat this operation once for a total of two cycles. Attach or tighten the central support at the longitudinal frame work. Seal chamber access doors.

NOTE 10—To accomplish this step, slotted clips can be used to attach the central support to the framework and to act as a guide. Prior to final torquing or clamping, these guides with slotted surfaces hold the clips in limited contact with both the frame and central support while allowing horizontal (longitudinal) movement and providing vertical bearing. Apply sliding forces without disturbing the seal between specimen frame and test chamber and between panel and frame. Paragraph 11.2 is optional if this test method is performed in tandem with and following Test Method E1680, and if 11.2 was not excluded in Test Method E1680.

11.3 Preload the test specimen to the positive static air pressure differential defined in 10.2. Apply the air pressure promptly, maintain the pressure for a minimum of 10 s, and then remove the pressure. Allow recovery for 2 min. Preload the test specimen to the negative static air pressure differential defined in 10.2, hold the pressure for a minimum of 10 s, and then unload the pressure. Allow recovery for 2 min. Repeat this positive and negative preloading cycle two additional times for a total of three cycles. Section 11.3 is optional if this test method follows Test Method E1680, if 11.3 was not excluded in Test Method E1680, and if the pressures determined for this test method are bounded by the preload pressures of Test Method E1680.

11.4 Open all specimen overflow devices described in 8.3. Observe and record the panel surface temperature prior to spray. Adjust the water spray to the specified rate.

11.5 Apply the specified air-pressure difference in 10.1 promptly and maintain this pressure for 15 min while applying the specified rate of water spray.

11.6 Observe and record the ponded water temperature and depth. Remove the air-pressure difference and stop the water.

11.7 Observe and record the points of water leakage (if any).

## 12. Report

12.1 Report the following information:

12.1.1 Date of test and date of report.

12.1.2 Identification of the specimen (manufacturer, source of supply, dimensions, model, type, materials, and other pertinent information).

12.1.3 Detailed drawings of the specimen that provide a description of the physical characteristics including dimensional section profiles, framing location, panel arrangement,

installation and spacing of anchorage and clips, accessories, sealants, and any other pertinent construction details. Any modifications made on the specimen to obtain the reported value shall be noted on the drawings.

12.1.4 A statement or tabulation of pressure differences exerted across the specimen during preload and during the test and the water application rates during the test.

12.1.5 A statement of panel surface temperature prior to and during the test and of the ponded water depth during the test.

12.1.6 A record of all points of water penetration on the indoor face of the test specimen and of water leakage as defined in 3.2.3.

12.1.7 When the test method is performed in sequence with other test methods on the specimen, a statement of other test method(s), the corresponding test report number(s), and the test sequence shall be included.

12.1.8 When the tests are made to check the conformity of the specimen to a particular specification, an identification or description of that specification shall be included.

12.1.9 A statement that the test or tests were conducted in accordance with this test method, including last date of calibration or a complete description of any deviations from this method.

12.2 If several identical specimens of a component are tested, the results for all specimens shall be reported, each specimen being properly identified, particularly with respect to distinguishing features of differing adjustments. A separate drawing of each specimen shall not be required if all differences between them are noted on the drawings provided.

### **13. Precision and Bias**

13.1 No statement is made either on the precision or bias of this test method measuring water leakage since the result merely states whether there is conformance to the criteria specified for success.

### **14. Keywords**

14.1 air; air pressure; leakage; mastic; metal; panel; ponding; rain; roof; roof panel; pressure; side lap; side seam; static; structural; thermal expansion; water; water leakage; water penetration; water-spray

*ASTM International takes no position respecting the validity of any patent rights asserted in connection with any item mentioned in this standard. Users of this standard are expressly advised that determination of the validity of any such patent rights, and the risk of infringement of such rights, are entirely their own responsibility.*

*This standard is subject to revision at any time by the responsible technical committee and must be reviewed every five years and if not revised, either reapproved or withdrawn. Your comments are invited either for revision of this standard or for additional standards and should be addressed to ASTM International Headquarters. Your comments will receive careful consideration at a meeting of the responsible technical committee, which you may attend. If you feel that your comments have not received a fair hearing you should make your views known to the ASTM Committee on Standards, at the address shown below.*

*This standard is copyrighted by ASTM International, 100 Barr Harbor Drive, PO Box C700, West Conshohocken, PA 19428-2959, United States. Individual reprints (single or multiple copies) of this standard may be obtained by contacting ASTM at the above address or at 610-832-9585 (phone), 610-832-9555 (fax), or service@astm.org (e-mail); or through the ASTM website (www.astm.org). Permission rights to photocopy the standard may also be secured from the ASTM website (www.astm.org/COPYRIGHT).*