



Standard Test Methods for Chemical Analysis of Nickel, Cobalt and High-Temperature Alloys¹

This standard is issued under the fixed designation E1473; the number immediately following the designation indicates the year of original adoption or, in the case of revision, the year of last revision. A number in parentheses indicates the year of last reapproval. A superscript epsilon (ϵ) indicates an editorial change since the last revision or reapproval.

1. Scope

1.1 These test methods describe the chemical analysis of nickel, cobalt and high-temperature alloys having chemical compositions within the following limits:

Element	Composition Range, %
Aluminum	0.005 to 7.00
Beryllium	0.001 to 0.05
Boron	0.001 to 1.00
Calcium	0.002 to 0.05
Carbon	0.001 to 1.10
Chromium	0.10 to 33.00
Cobalt	0.10 to 75.00
Copper	0.01 to 35.00
Iron	0.01 to 50.00
Lead	0.001 to 0.01
Magnesium	0.001 to 0.05
Manganese	0.01 to 3.0
Molybdenum	0.01 to 30.0
Niobium (Columbium)	0.01 to 6.0
Nickel	0.10 to 98.0
Nitrogen	0.001 to 0.20
Phosphorus	0.002 to 0.08
Sulfur	0.002 to 0.10
Silicon	0.01 to 5.00
Tantalum	0.005 to 1.00
Tin	0.002 to 0.10
Titanium	0.01 to 5.00
Tungsten	0.01 to 18.00
Vanadium	0.01 to 3.25
Zinc	0.001 to 0.01
Zirconium	0.01 to 2.50

1.2 The test methods in this standard are contained in the sections indicated as follows:

Aluminum, Total by the 8-Quinolinol Gravimetric Method (0.20 % to 7.00 %)	53 to 60
Chromium by the Atomic Absorption Method (0.018 % to 1.00 %)	91 to 100

¹ These test methods are under the jurisdiction of ASTM Committee E01 on Analytical Chemistry for Metals, Ores, and Related Materials and are the direct responsibility of Subcommittee E01.08 on Ni and Co and High Temperature Alloys.

Current edition approved April 1, 2016. Published May 2016. Originally approved in 1992. Last previous edition approved in 2009 as E1473 – 09. DOI: 10.1520/E1473-16.

Chromium by the Peroxydisulfate Oxidation—Titration Method (0.10 % to 33.00 %)	101 to 109
Cobalt by the Ion-Exchange-Potentiometric Titration Method (2 % to 75 %)	25 to 32
Cobalt by the Nitroso-R-Salt Spectrophotometric Method (0.10 % to 5.0 %)	33 to 42
Copper by Neocuproine Spectrophotometric Method (0.010 % to 10.00 %)	43 to 52
Iron by the Silver Reduction Titrimetric Method (1.0 % to 50.0 %)	118 to 125
Manganese by the Metaperiodate Spectrophotometric Method (0.05 % to 2.00 %)	8 to 17
Molybdenum by the Ion Exchange—8-Hydroxyquinoline Gravimetric Method (1.5 % to 30 %)	110 to 117
Molybdenum by the Spectrophotometric Method (0.01 % to 1.50 %)	79 to 90
Nickel by the Dimethylglyoxime Gravimetric Method (0.1 % to 84.0 %)	61 to 68
Niobium by the Ion Exchange—Cupferron Gravimetric Method (0.5 % to 6.0 %)	126 to 133
Silicon by the Gravimetric Method (0.05 % to 5.00 %)	18 to 24
Tantalum by the Ion Exchange—Pyrogallol Spectrophotometric Method (0.03 % to 1.0 %)	134 to 142
Tin by the Solvent Extraction-Atomic Absorption Method (0.002 % to 0.10 %)	69 to 78

1.3 Other test methods applicable to the analysis of nickel alloys that may be used in lieu of or in addition to this method are Test Methods E1019, E1834, E1835, E1917, E1938, E2465, E2594, E2823.

1.4 Some of the composition ranges given in 1.1 are too broad to be covered by a single method, and therefore, these test methods contain multiple methods for some elements. The user must select the proper test method by matching the information given in the scope and interference sections of each test method with the composition of the alloy to be analyzed.

1.5 The values stated in SI units are to be regarded as standard.

1.6 *This standard does not purport to address all of the safety concerns, if any, associated with its use. It is the responsibility of the user of this standard to establish appropriate safety and health practices and determine the applicability of regulatory limitations prior to use. Specific hazard*

statements are given in Section 7 and in 13.4, 15.1.1, 15.1.2, 21.2, 22.5, 57.3, 114.5, 115.4, 130.4, 130.5, 138.5, and 138.6.

2. Referenced Documents

2.1 *ASTM Standards*:²

- D1193** Specification for Reagent Water
- E29** Practice for Using Significant Digits in Test Data to Determine Conformance with Specifications
- E50** Practices for Apparatus, Reagents, and Safety Considerations for Chemical Analysis of Metals, Ores, and Related Materials
- E60** Practice for Analysis of Metals, Ores, and Related Materials by Spectrophotometry
- E135** Terminology Relating to Analytical Chemistry for Metals, Ores, and Related Materials
- E173** Practice for Conducting Interlaboratory Studies of Methods for Chemical Analysis of Metals (Withdrawn 1998)³
- E350** Test Methods for Chemical Analysis of Carbon Steel, Low-Alloy Steel, Silicon Electrical Steel, Ingot Iron, and Wrought Iron
- E351** Test Methods for Chemical Analysis of Cast Iron—All Types
- E352** Test Methods for Chemical Analysis of Tool Steels and Other Similar Medium- and High-Alloy Steels
- E353** Test Methods for Chemical Analysis of Stainless, Heat-Resisting, Maraging, and Other Similar Chromium-Nickel-Iron Alloys
- E354** Test Methods for Chemical Analysis of High-Temperature, Electrical, Magnetic, and Other Similar Iron, Nickel, and Cobalt Alloys
- E882** Guide for Accountability and Quality Control in the Chemical Analysis Laboratory
- E1019** Test Methods for Determination of Carbon, Sulfur, Nitrogen, and Oxygen in Steel, Iron, Nickel, and Cobalt Alloys by Various Combustion and Fusion Techniques
- E1601** Practice for Conducting an Interlaboratory Study to Evaluate the Performance of an Analytical Method
- E1834** Test Method for Analysis of Nickel Alloys by Graphite Furnace Atomic Absorption Spectrometry
- E1835** Test Method for Analysis of Nickel Alloys by Flame Atomic Absorption Spectrometry
- E1917** Test Method for Determination of Phosphorus in Nickel, Ferronickel, and Nickel Alloys by Phosphovanadomolybdate Spectrophotometry
- E1938** Test Method for Determination of Titanium in Nickel Alloys by Diantiprylmethane Spectrophotometry
- E2465** Test Method for Analysis of Ni-Base Alloys by Wavelength Dispersive X-Ray Fluorescence Spectrometry
- E2594** Test Method for Analysis of Nickel Alloys by Inductively Coupled Plasma Atomic Emission Spectrometry (Performance-Based Method)

E2823 Test Method for Analysis of Nickel Alloys by Inductively Coupled Plasma Mass Spectrometry (Performance-Based Method)

2.2 *Other Document*:

ISO 5725 Precision of Test Methods—Determination of Repeatability and Reproducibility for Inter-Laboratory Tests⁴

3. Terminology

3.1 For definitions of terms used in these test methods, refer to Terminology **E135**.

4. Significance and Use

4.1 These test methods for the chemical analysis of metals and alloys are primarily intended as referee methods to test such materials for compliance with compositional specifications, particularly those under the jurisdiction of ASTM Committee **B02** on Nonferrous Metals and Alloys. It is assumed that all who use these test methods will be trained analysts capable of performing common laboratory procedures skillfully and safely. It is expected that work will be performed in a properly equipped laboratory under appropriate quality control practices such as those described in Guide **E882**.

5. Apparatus, Reagents, and Instrumental Practice

5.1 *Apparatus*—Specialized apparatus requirements are listed in the “Apparatus” section in each test method.

5.2 *Reagents*:

5.2.1 *Purity of Reagents*—Unless otherwise indicated, all reagents used in these test methods shall conform to the specifications of the Committee on Analytical Reagents of the American Chemical Society where such specifications are available.⁵ Other chemicals may be used, provided it is first ascertained that they are of sufficiently high purity to permit their use without adversely affecting the expected performance of the determination, as indicated in the Precision and Bias sections.

5.2.2 *Purity of Water*—Unless otherwise indicated, references to water shall be understood to mean reagent water conforming to Type I or II of Specification **D1193**. Type III or IV may be used if they effect no measurable change in the blank or sample.

5.3 *Spectrophotometric Practice*—Spectrophotometric practice prescribed in these test methods shall conform to Practice **E60**.

6. Interlaboratory Studies and Rounding Calculated Values

6.1 These test methods have been evaluated in accordance with Practice **E173** (withdrawn 1997) or ISO 5725. The

² For referenced ASTM standards, visit the ASTM website, www.astm.org, or contact ASTM Customer Service at service@astm.org. For *Annual Book of ASTM Standards* volume information, refer to the standard’s Document Summary page on the ASTM website.

³ The last approved version of this historical standard is referenced on www.astm.org.

⁴ Available from American National Standards Institute (ANSI), 25 W. 43rd St., 4th Floor, New York, NY 10036, <http://www.ansi.org>.

⁵ *Reagent Chemicals, American Chemical Society Specifications*, American Chemical Society, Washington, DC, www.chemistry.org. For suggestions on the testing of reagents not listed by the American Chemical Society, see the *United States Pharmacopeia and National Formulary*, U.S. Pharmacopeial Convention, Inc. (USPC), Rockville, MD, <http://www.usp.org>.

Reproducibility R2 of Practice E173 corresponds to the Reproducibility Index R of Practice E1601. The Repeatability R1 of Practice E173 corresponds to the Repeatability Index r of Practice E1601.

6.2 Rounding of test results obtained using this Test Method shall be performed in accordance with Practice E29, Rounding Method, unless an alternative rounding method is specified by the customer or applicable material specification.

7. Hazards

7.1 For precautions to be observed in the use of certain reagents and equipment in these test methods, refer to Practices E50.

MANGANESE BY THE METAPERIODATE SPECTROPHOTOMETRIC METHOD

8. Scope

8.1 This test method covers the determination of manganese from 0.05 % to 2.00 %.

9. Summary of Test Method

9.1 Manganous ions are oxidized to permanganate ions by treatment with periodate. Tungsten when present in amounts greater than 0.5 % is kept in solution with H_3PO_4 . Solutions of the samples are fumed with HClO_4 so that the effect of periodate is limited to the oxidation of manganese. Spectrophotometric measurements are made at 545 nm.

10. Concentration Range

10.1 The recommended concentration range is from 0.15 mg to 0.8 mg of manganese per 50 mL of solution, using a 1-cm cell (Note 1) and a spectrophotometer with a band width of 10 nm or less.

NOTE 1—This test method has been written for cells having a 1-cm light path and a “narrow-band” instrument. The concentration range depends upon band width and spectral region used as well as cell optical path length. Cells having other dimensions may be used, provided suitable adjustments can be made in the amounts of sample and reagents used.

11. Stability of Color

11.1 The color is stable for at least 24 h.

12. Interferences

12.1 HClO_4 treatment, which is used in the procedure, yields solutions which can be highly colored due to the presence of hexavalent chromium Cr(VI) ions. Although these ions and other colored ions in the sample solution undergo no further change in color quality upon treatment with metaperiodate ion, the following precautions must be observed when filter spectrophotometers are used: Select a filter with maximum transmittance between 545 nm and 565 nm. The filter must transmit not more than 5 % of its maximum at a wavelength shorter than 530 nm. The band width of the filter should be less than 30 nm when measured at 50 % of its maximum transmittance. Similar restrictions apply with respect to the wavelength region employed when other “wide-band” instruments are used.

12.2 The spectral transmittance curve of permanganate ions exhibits two useful minima, one at approximately 526 nm, and the other at 545 nm. The latter is recommended when a “narrow-band” spectrophotometer is used.

12.3 Tungsten, when present in amounts of more than 0.5 % interferes by producing a turbidity in the final solution. A special procedure is provided for use with samples containing more than 0.5 % tungsten which eliminates the problem by preventing the precipitation of the tungsten.

13. Reagents

13.1 *Manganese, Standard Solution* (1 mL = 0.032 mg Mn)—Transfer the equivalent of 0.4000 g of assayed, high-purity manganese (purity 99.99 % minimum), to a 500-mL volumetric flask and dissolve in 20 mL of HNO_3 by heating. Cool, dilute to volume, and mix. Using a pipet, transfer 20 mL to a 500-mL volumetric flask, dilute to volume, and mix.

13.2 *HNO_3 - H_3PO_4 Mixture*—Cautiously, while stirring, add 100 mL of HNO_3 and 400 mL of H_3PO_4 to 400 mL of water. Cool, dilute to 1 L, and mix. Prepare fresh as needed.

13.3 *Potassium Metaperiodate Solution* (7.5 g/L)—Dissolve 7.5 g of potassium metaperiodate (KIO_4) in 200 mL of hot HNO_3 (1 + 1), add 400 mL of H_3PO_4 , cool, dilute to 1 L, and mix.

13.4 *Water, Pretreated with Metaperiodate*—Add 20 mL of KIO_4 solution to 1 L of water, mix, heat at not less than 90 °C for 20 to 30 min, and cool. Use this water to dilute solutions to volume that have been treated with KIO_4 solution to oxidize manganese, and thus avoid reduction of permanganate ions by any reducing agents in the untreated water. (**Caution**—Avoid the use of this water for other purposes.)

14. Preparation of Calibration Curve

14.1 *Calibration Solutions*—Using pipets, transfer (5, 10, 15, 20, and 25) mL of manganese standard solution (1 mL = 0.032 mg Mn) to 50-mL borosilicate glass volumetric flasks, and, if necessary, dilute to approximately 25 mL. Proceed as directed in 14.3.

14.2 *Reference Solution*—Transfer approximately 25 mL of water to a 50-mL borosilicate glass volumetric flask. Proceed as directed in 14.3.

14.3 *Color Development*—Add 10 mL of KIO_4 solution, and heat the solutions at not less than 90 °C for 20 min to 30 min (Note 2). Cool, dilute to volume with pretreated water, and mix.

NOTE 2—Immersing the flasks in a boiling water bath is a preferred means of heating them for the specified period to ensure complete color development.

14.4 Spectrophotometry:

14.4.1 *Multiple-Cell Spectrophotometer*—Measure the cell correction using the Reference Solution (14.2) in absorption cells with a 1-cm light path and using a light band centered at approximately 545 nm. Using the test cell, take the spectrophotometric readings of the calibration solutions versus the reference solution (14.2).

14.4.2 *Single-Cell Spectrophotometer*—Transfer a suitable portion of the reference solution (14.2) to an absorption cell with a 1-cm light path and adjust the spectrophotometer to the initial setting, using a light band centered at approximately 545 nm. While maintaining this adjustment, take the spectrophotometric readings of the calibration solutions.

14.5 *Calibration Curve*—Follow the instrument manufacturer’s instructions for generating the calibration curve.

15. Procedure

15.1 *Test Solutions*—Select and weigh a sample in accordance with the following.

15.1.1

Manganese, %	Sample Weight, g	Tolerance in Sample Weight, mg	Dilution, mL
0.01 to 0.5	0.80	0.5	100
0.45 to 1.0	0.35	0.3	100
0.85 to 2.0	0.80	0.5	500

15.1.2 *For Samples Containing Not More Than 0.5 % Tungsten*—(Warning—See Practices E50 for details pertaining to the special hazards associated with the use of HClO₄.)

15.1.2.1 To dissolve samples that do not require HF, add 8 mL to 10 mL of HCl (1 + 1), and heat. Add HNO₃ as needed to hasten dissolution, and then add 3 mL to 4 mL in excess. When dissolution is complete, cool, then add 10 mL of HClO₄; evaporate to fumes to oxidize chromium, if present, and to expel HCl. Continue fuming until salts begin to separate. Cool, add 50 mL of water, and digest if necessary to dissolve the salts. Cool and transfer the solution to a 100-mL volumetric flask. Proceed to 15.1.4.

15.1.2.2 For samples whose dissolution is hastened by HF, add 8 mL to 10 mL of HCl (1 + 1), and heat. Add HNO₃ and a few drops of HF as needed to hasten dissolution, and then add 3 mL to 4 mL of HNO₃. When dissolution is complete, cool, then add 10 mL of HClO₄, evaporate to fumes to oxidize chromium, if present, and to expel HCl. Continue fuming until salts begin to separate. Cool, add 50 mL of water, digest if necessary to dissolve the salts, cool, and transfer the solution to either a 100-mL or 500-mL volumetric flask as indicated in 15.1. Proceed to 15.1.4.

15.1.3 *For Samples Containing More Than 0.5 % Tungsten*—(Warning—See Practices E50 for details pertaining to the special hazards associated with the use of HClO₄.)

15.1.3.1 To dissolve samples that do not require HF, add 8 mL to 10 mL of H₃PO₄, 10 mL of HClO₄, 5 mL to 6 mL of H₂SO₄, and 3 mL to 4 mL of HNO₃. Heat moderately until the sample is decomposed, and then heat to copious white fumes for 10 min to 12 min or until the chromium is oxidized and the HCl is expelled, but avoid heating to fumes of SO₃. Cool, add 50 mL of water, and digest if necessary to dissolve the salts. Transfer the solution to either a 100-mL or 500-mL volumetric flask as directed in 15.1. Proceed to 15.1.4.

15.1.3.2 For samples whose dissolution is hastened by HF, add 8 mL to 10 mL of H₃PO₄, 10 mL of HClO₄, 5 mL to 6 mL of H₂SO₄, 3 mL to 4 mL of HNO₃, and a few drops of HF. Heat moderately until the sample is decomposed, and then heat to copious white fumes for 10 min to 12 min or until the chromium is oxidized and the HCl is expelled, but avoid

heating to fumes of SO₃. Cool, add 50 mL of water, digest if necessary to dissolve the salts, cool, and transfer the solution to a 100-mL or 500-mL volumetric flask as directed in 15.1.1. Proceed to 15.1.4.

15.1.3.3 Cool the solution, dilute to volume mix. Allow insoluble matter to settle, or dry-filter through a coarse paper and discard the first 15 mL to 20 mL of the filtrate, before taking aliquots.

15.1.4 Using a pipet, transfer 20-mL aliquots to two 50-mL borosilicate glass volumetric flasks; treat one as directed in 15.3 and the other as directed in 15.4.1.

15.2 *Reagent Blank Solution*—Carry a reagent blank through the entire procedure using the same amounts of all reagents with the sample omitted.

15.3 *Color Development*—Proceed as directed in 14.3.

15.4 *Reference Solutions:*

15.4.1 *Background Color Solution*—To one of the sample aliquots in a 50-mL volumetric flask, add 10 mL of HNO₃-H₃PO₄ mixture, and heat the solution at not less than 90 °C for 20 min to 30 min (Note 2). Cool, dilute to volume (with untreated water), and mix.

15.4.2 *Reagent Blank Reference Solution*—Transfer the reagent blank solution (15.2) to the same size volumetric flask as used for the test solutions and transfer the same size aliquots as used for the test solutions to two 50-mL volumetric flasks. Treat one portion as directed in 15.3 and use as reference solution for test samples. Treat the other as directed in 15.4.1 and use as reference solution for background color solutions.

15.5 *Spectrophotometry*—Establish the cell corrections with the reagent blank Reference solution to be used as a reference solution for background color solutions. Take the spectrophotometric readings of the background color solutions and the test solutions versus the respective reagent blank reference solutions as directed in 14.4.

16. Calculation

16.1 Convert the net spectrophotometric reading of the test solution and of the background color solution to milligrams of manganese by means of the calibration curve. Calculate the percent of manganese as follows:

$$\text{Manganese, \%} = (A - B)/(C \times 10) \quad (1)$$

where:

A = manganese found in 50 mL of the final test solution, mg,

B = apparent manganese found in 50 mL of the final background color solution, mg, and

C = sample weight represented in 50 mL of the final test solution, g.

17. Precision and Bias

17.1 *Precision*—Nine laboratories cooperated in testing this test method and obtained the data summarized in Table 1.

17.2 *Bias*—The bias of this test method may be judged by comparing accepted reference values with the corresponding arithmetic average obtained by interlaboratory testing, such as the data listed in Table 1.

TABLE 1 Statistical Information—Manganese by the Metaperiodate Spectrophotometric Method

Test Specimen	Manganese Found, %	Repeatability (R_1 , Practice E173)	Reproducibility (R_2 , Practice E173)
1. Nickel alloy, 77Ni-20Cr (NIST 169, 0.073 % Mn, certified)	0.074	0.002	0.008
2. High-temperature alloy, 68Ni-14Cr-7Al-6Mo (NIST 1205, 0.29 % Mn, not certified)	0.289	0.007	0.026
3. Cobalt alloy, 41Co-20Ni-20Cr-4Mo-4W (NIST 168, 1.50 % Mn, not certified)	1.49	0.03	0.08
4. Stainless steel 18Cr-9Ni (NIST 101e, 1.77 % Mn, certified)	1.79	0.07	0.07

SILICON BY THE GRAVIMETRIC METHOD

18. Scope

18.1 This test method covers the determination of silicon from 0.05 % to 5.00 % in alloys containing not more than 0.1 % boron.

19. Summary of Test Method

19.1 After dissolution of the sample, silicic acid is dehydrated by fuming with sulfuric or HClO₄ acid. The solution is filtered, and the impure silica is ignited and weighted. The silica is then volatilized with HF. The residue is ignited and weighed; the loss in weight represents silica.

20. Interferences

20.1 The elements normally present do not interfere. When boron is present in amounts greater than 0.1 %, the sample solution requires special treatment with methyl alcohol. However, since no boron steels were tested, this special treatment was not evaluated and is not described in this test method.

21. Reagents

21.1 The analyst should ensure by analyzing blanks and other checks that possible silicon contamination of reagents will not significantly bias the results.

21.2 HClO₄—(Warning—See Practices E50 for details pertaining to the special hazards associated with the use of HClO₄.)

21.2.1 Select a lot of HClO₄ that contains not more than 0.0002 % silicon for the analysis of samples containing silicon in the range from 0.02 % to 0.10 % and not more than 0.0004 % silicon for samples containing more than 0.10 % by determining duplicate values for silicon as directed in 21.2.2 – 21.2.6.

21.2.2 Transfer 15 mL of HClO₄ (Note 3) to each of two 400-mL beakers. To one of the beakers transfer an additional 50 mL of HClO₄. Using a pipet, transfer 20 mL of sodium silicate solution (1 mL = 1.00 mg Si) to each of the beakers. Evaporate the solutions to fumes and heat for 15 min to 20 min

at such a rate that HClO₄ refluxes on the sides of the beakers. Cool sufficiently, and add 100 mL of water (40 °C to 50 °C).

NOTE 3—The 15-mL addition of HClO₄ can be from the same lot as the one to be tested. Once a lot has been established as having less than 0.0002 % silicon, it should preferably be used for the 15-mL addition in all subsequent tests of other lots of acid.

21.2.3 Add paper pulp and filter immediately, using low-ash 11-cm medium-porosity filter papers. Transfer the precipitates to the papers, and scrub the beakers thoroughly with a rubber-tipped rod. Wash the papers and precipitates alternately with 3-mL to 5-mL portions of hot HCl (1 + 19) and hot water, for a total of six times. Finally wash the papers twice with H₂SO₄ (1 + 49). Transfer the papers to platinum crucibles.

21.2.4 Dry the papers and heat at 600 °C until the carbon is removed. Finally ignite at 1100 °C to 1150 °C to constant weight (at least 30 min). Cool in a desiccator and weigh.

21.2.5 Add enough H₂SO₄ (1 + 1) to moisten the SiO₂, and add 3 mL to 5 mL of HF. Evaporate to dryness and then heat at a gradually increasing rate until H₂SO₄ is removed. Ignite for 15 min at 1100 °C to 1150 °C, cool in a desiccator, and weigh.

21.2.6 Calculate the percentage of silicon as follows:

$$\text{Silicon, \%} = [(A - B) - (C - D)] \times 0.4674/E \times 100 \quad (2)$$

where:

- A = initial weight of crucible plus impure SiO₂ when 65 mL of HClO₄ was taken, g,
- B = final weight of crucible plus impurities when 65 mL of HClO₄ was taken, g,
- C = final weight of crucible plus impure SiO₂ when 15 mL of HClO₄ was taken, g,
- D = final weight of crucible plus impurities when 15 mL of HClO₄ was taken, g, and
- E = nominal weight (80 g) of 50 mL of HClO₄.

21.3 Sodium Silicate Solution (1.00 mg/mL Si)—Transfer 11.0 g of sodium silicate (Na₂SiO₃·9H₂O) to a 400-mL beaker. Add 150 mL of water and dissolve the salt. Filter through a medium paper, collecting the filtrate in a 1-L volumetric flask, dilute to volume, and mix. Store in a polyethylene bottle. Use this solution to determine the suitability of the HClO₄.

21.4 Tartaric Acid Solution (20.6 g/L)—Dissolve 20.6 g of tartaric acid (C₄H₆O₆) in water, dilute to 1 L, and filter.

21.5 Water—Use freshly prepared Type II water known to be free of silicon. Water distilled from glass, demineralized in columns containing silicon compounds, or stored for extended periods in glass, or combination thereof, has been known to absorb silicon.

22. Procedure

22.1 Select and weigh a sample in accordance with the following.

22.1.1

Silicon, %	Sample Weight, g	Tolerance in Sample Weight, mg	Dehydrating Acid, mL	
			H ₂ SO ₄ (1+4)	HClO ₄
0.05 to 0.10	5.0	5	150	75
0.10 to 1.0	4.0	4	100	60
1.0 to 2.0	3.0	3	100	50
2.0 to 5.0	2.0	2	100	40

22.1.2 Transfer the sample to a 400-mL beaker or a 300-mL porcelain casserole. Proceed as directed in 22.2 or 22.3.

22.2 *H₂SO₄ Dehydration*—if tungsten is greater than 0.5 %.

22.2.1 Add amounts of HCl or HNO₃, or mixtures and dilutions of these acids, that are sufficient to dissolve the sample; and then add the H₂SO₄ (1 + 4) as specified in 21.1, and cover. Heat until dissolution is complete. Remove and rinse the cover glass; substitute a ribbed cover glass.

22.2.2 Evaporate until salts begin to separate; at this point evaporate the solution rapidly to the first appearance of fumes and fume strongly for 2 min to 3 min. Cool sufficiently, and add 100 mL of water (40 °C to 50 °C). Stir to dissolve the salts and heat, if necessary, but do not boil. Proceed immediately as directed in 22.4.

22.3 *HClO₄ Acid Dehydration*—if tungsten is less than 0.5 % or use 22.2. (**Warning**—See Practices E60 for details pertaining to the special hazards associated with the use of HClO₄.)

22.3.1 Add amounts of HCl or HNO₃, or mixtures and dilutions of these acids, which are sufficient to dissolve the sample, and cover. Heat until dissolution is complete. Add HNO₃ to provide a total of 35 mL to 40 mL, followed by HClO₄ as specified in the table in 22.1. Remove and rinse the cover glass; substitute a ribbed cover glass.

22.3.2 Evaporate the solution to fumes and heat for 15 min to 20 min at such a rate that the HClO₄ refluxes on the sides of the container. Cool sufficiently and add 100 mL of water (40 °C to 50 °C). Stir to dissolve the salts and heat to boiling. If the sample solution contains more than 100 mg of chromium, add, while stirring, 1 mL of tartaric acid solution for each 25 mg of chromium.

22.4 Add paper pulp and filter immediately, on a low-ash 11-cm medium-porosity filter paper. Collect the filtrate in a 600-mL beaker. Transfer the precipitate to the paper, and scrub the container thoroughly with a rubber-tipped rod. Wash the paper and precipitate alternately with 3-mL to 5-mL portions of hot HCl (1 + 19) and hot water until iron salts are removed but for not more than a total of ten washings. If 22.3 was followed, wash the paper twice more with H₂SO₄ (1 + 49), but do not collect these washings in the filtrate; discard the washings. Transfer the paper to a platinum crucible and reserve.

22.5 Add 15 mL of HNO₃ to the filtrate, stir, and evaporate as directed either in 22.2 or 22.3, depending upon the dehydrating acid used. Filter immediately, using a low-ash 9-cm 100-porosity filter paper, and wash as directed in 22.4.

22.6 Transfer the paper and precipitate to the reserved platinum crucible. Dry the papers and then heat the crucible at 600 °C until the carbon is removed. Finally ignite at 1100 °C to 1150 °C to constant weight (at least 30 min). Cool in a desiccator and weigh.

22.7 Add enough H₂SO₄ (1 + 1) to moisten the impure silica (SiO₂), and add 3 mL to 5 mL of HF. Evaporate to dryness and then heat at a gradually increasing rate until H₂SO₄. Ignite at 1100 °C to 1150 °C for 15 min, cool in a desiccator, and weigh. If the sample contains more than 0.5 % tungsten, ignite at 750 °C instead of 1100 °C to 1150 °C after volatilization of SiO₂.

23. Calculation

23.1 Calculate the percent of silicon as follows:

$$\text{Silicon, \%} = \left[\frac{(A - B) \times 0.4674}{C} \right] \times 100 \quad (3)$$

where:

- A = initial weight of crucible and impure SiO₂, g,
- B = final weight of crucible and residue, g, and
- C = sample used, g.

24. Precision and Bias

24.1 Eleven laboratories cooperated in testing this test method and obtained the data summarized in Table 2. A sample with silicon content near the upper limit of the scope was not available for testing.

24.2 *Bias*—No data are presently available to determine the accuracy of this method.

COBALT BY THE ION-EXCHANGE-POTENTIOMETRIC TITRATION METHOD

25. Scope

25.1 This test method covers the determination of cobalt from 2 % to 75 %.

26. Summary of Test Method

26.1 Cobalt is separated from interfering elements by selective elution from an anion-exchange column using HCl. The cobalt is oxidized to the trivalent state with ferricyanide, and the excess ferricyanide is titrated potentiometrically with cobalt solution.

27. Interferences

27.1 The elements ordinarily present do not interfere if their contents are under the maximum limits shown in 1.1.

28. Apparatus

28.1 *Ion-Exchange Column*, approximately 25 mm in diameter and 300 mm in length, tapered at one end, and provided with a stopcock to control the flow rate, and a second, lower stopcock to stop the flow. A Jones Reductor (Fig. 1), may be adapted to this method. It consists of a column 19 mm in diameter and 250 mm in length, of 20-mesh to 30-mesh amalgamated zinc. To amalgamate the zinc, shake 800 g of zinc (as free of iron as possible) with 400 mL of HgCl₂ solution

TABLE 2 Statistical Information—Silicon

Test Specimen	Silicon Found, %	Repeatability (R ₁ , Practice E173)	Reproducibility (R ₂ , Practice E173)
HClO ₄ Dehydration			
1. Ni-base alloy 75Ni-12Cr-6Al- 4Mo-2Cb-0.7Ti	0.029	0.006	0.026
H ₂ SO ₄ Dehydration			
1. Ni-base alloy 75Ni-12Cr-6Al- 4Mo-2Cb-0.7Ti	0.030	0.007	0.030
2. Co-base alloy 66Co-28Cr-4W-1.5Ni	1.01	0.03	0.06

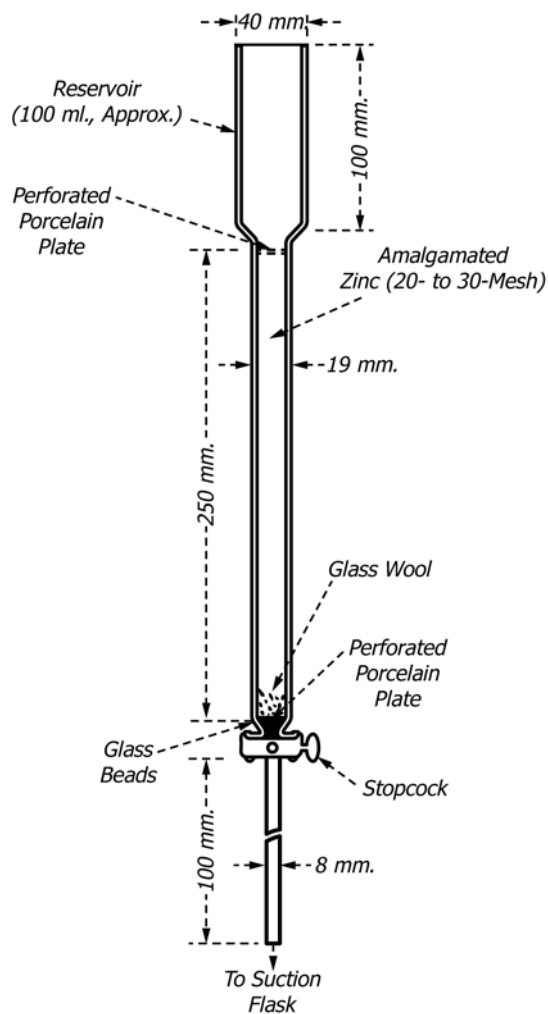

FIG. 1 Jones Reductor

(25 g/L) in a 1-L flask for 2 min. Wash several times with H_2SO_4 (2 + 98), and then thoroughly with water. The reductor, when idle, should always be kept filled with distilled water to above the top of the zinc. A reservoir for the eluants may be added at the top of the column.

28.2 *Apparatus for Potentiometric Titrations*—Instruments for detecting the end points in pH (acid-base), oxidation-reduction, precipitation and complexation titrations consist of a pair of suitable electrodes, a potentiometer, a buret, and a motor-driven stirrer. Titrations are based on the fact that when two dissimilar electrodes are placed in a solution there is a potential difference between them. This potential difference depends on the composition of the solution and changes as the titrant is added. A high-impedance electronic voltmeter follows the changes accurately. The end point of the titration may be determined by adding the titrant until the potential difference attains a predetermined value or by plotting the potential difference versus the titrant volume, the titrant being added until the end point has been passed.

28.2.1 An elaborate or highly sensitive and accurate potentiometer is not necessary for potentiometric titrations because the absolute cell voltage needs to be known only approximately, and variations of less than 1 MV are not

significant. Such instruments should have a range of about 1.5 V and a readability of about 1 MV. Many pH meters are also suitable for potentiometric titrations.

28.2.2 The electrode system must consist of a reference electrode and an indicator electrode. The reference electrode maintains a constant, but not necessarily a known or reproducible potential during the titration. The potential of the indicator electrode does change during the titration; further, the indicator electrode must be one that will quickly come to equilibrium. In this procedure a platinum indicator electrode and a saturated calomel reference electrode are appropriate.

28.3 Platinum and a saturated calomel electrodes.

29. Reagents

29.1 *Ammonium Citrate Solution* (200 g/L).

29.2 *Cobalt, Standard Solution* (1 mL = 1.5 mg of Co):

29.2.1 Dry a weighing bottle in an oven at 130 °C for 1 h, cool in a desiccator, and weigh. Transfer 3.945 g of cobalt sulfate ($CoSO_4$)⁶ that has been heated at 550 °C for 1 h to the

⁶ Cobalt sulfate (99.9 % minimum) prepared from the hexamine salt by G. Frederick Smith Chemical Co., Columbus, OH, is satisfactory for this purpose.

weighing bottle. Dry the bottle and contents at 130 °C for 1 h, cool in desiccator, stopper the bottle, and weigh. The difference in weight is the amount of CoSO₄ taken. Transfer the weighed CoSO₄ to a 400-mL beaker, rinse the weighing bottle with water, and transfer the rinsings to the beaker. Add 150 mL of water and 20 mL of HNO₃, and heat to dissolve the salts. Cool, transfer to a 1-L volumetric flask, dilute to volume, and mix.

29.2.2 *Standardization*—Calculate the cobalt concentration as follows:

Cobalt, mg/mL = weight of CoSO₄, g, × 0.38026

29.3 Ion-Exchange Resin:⁷

29.3.1 Use an anion exchange resin of the alkyl quaternary ammonium type (chloride form) consisting of spherical beads having a nominal crosslinkage of 8 %, and 200-nominal to 400-nominal mesh size. To remove those beads greater than about 180 μm in diameter as well as the excessively fine beads, treat the resin as follows: Transfer a supply of the resin to a beaker, cover with water, and allow sufficient time (at least 30 min) for the beads to undergo maximum swelling. Place a No. 80 (180-μm) screen, 150 mm in diameter over a 2-L beaker. Prepare a thin slurry of the resin and pour it onto the screen. Wash the fine beads through the screen, using a small stream of water. Discard the beads retained on the screen, periodically, if necessary, to avoid undue clogging of the openings. When the bulk of the collected resin has settled, decant the water and transfer approximately 100 mL of resin to a 400-mL beaker. Add 200 mL of HCl (1 + 19), stir vigorously, allow the resin to settle for 4 min to 6 min, decant 150 mL to 175 mL of the suspension, and discard. Repeat the treatment with HCl (1 + 19) twice more, and reserve the coarser resin for the column preparation.

29.3.2 Prepare the column as follows: Place a 10-mm to 20-mm layer of glass wool or polyvinyl chloride plastic fiber in the bottom of the column, and add a sufficient amount of the prepared resin to fill the column to a height of approximately 140 mm. Place a 20-mm layer of glass wool or polyvinyl chloride plastic fiber at the top of the resin bed to protect it from being carried into suspension when the solutions are added. While passing a minimum of 35 mL of HCl (7 + 5) through the column, with the hydrostatic head 100 mm above the top of the resin bed, adjust the flow rate to not more than 3.0 mL/min. Drain to 10 mm to 20 mm above the top of the resin bed and then close the lower stopcock.

NOTE 4—The maximum limits of 0.125 g of cobalt and 0.500 g in the sample solution take into account the exchange capacity of the resin, the physical dimensions of the column, and the volume of eluants.

29.4 *Potassium Ferricyanide, Standard Solution* (1 mL = 3.0 mg of Co):

29.4.1 Dissolve 16.68 g of potassium ferricyanide (K₃Fe(CN)₆) in water and dilute to 1 L. Store the solution in a dark-colored bottle. Standardize the solution each day before use as follows: Transfer from a 50-mL buret approximately 20 mL of K₃Fe(CN)₆ solution to a 400-mL beaker. Record the buret reading to the nearest 0.01 mL. Add 25 mL of water, 10 mL of ammonium citrate solution, and 25 mL of NH₄OH.

Cool to 5 °C to 10 °C, and maintain this temperature during the titration. Transfer the beaker to the potentiometric titration apparatus. While stirring, titrate the K₃Fe(CN)₆ with the cobalt solution (1 mL = 1.5 mg Co) using a 50-mL buret. Titrate at a fairly rapid rate until the end point is approached, and then add the titrant in one-drop increments through the end point. After the addition of each increment, record the buret reading and voltage when equilibrium is reached. Estimate the buret reading at the end point to the nearest 0.01 mL.

29.4.2 Calculate the cobalt equivalent as follows (Note 5):

$$\text{Cobalt equivalent, mg/mL} = (A \times B)/C \quad (4)$$

where:

A = cobalt standard solution required to titrate the potassium ferricyanide solution, mL,

B = cobalt standard solution, mg/mL, and

C = potassium ferricyanide solution, mL.

NOTE 5—Duplicate or triplicate values should be obtained for the cobalt equivalent. The values obtained should check within (1 to 2) parts per thousand.

30. Procedure

30.1 Proceed as directed in 30.2 – 30.7, using 0.50 g samples for cobalt compositions not greater than 25%; at higher compositions use samples that represent between 100 mg and 125 mg of cobalt weighed to the nearest 0.1 mg.

30.2 Transfer a 0.50-g sample to a 150-mL beaker. Add 20 mL of a mixture of five parts of HCl and one part of HNO₃ (Note 6). Cover the beaker and digest at 60 °C to 70 °C until the sample is decomposed. Rinse and remove the cover. Place a ribbed cover glass on the beaker and evaporate the solution nearly to dryness, but do not bake. Cool, add 20 mL of HCl (7 + 5), and digest at 60 °C to 70 °C until salts are dissolved (approximately 10 min).

NOTE 6—Other ratios and concentrations of acids, with or without the addition of 1 mL to 2 mL of HF, are used for the decomposition of special grades of alloys.

Some alloys are decomposed more readily by a mixture of 5 mL of bromine, 15 mL of HCl, and one to two drops of HF.

30.3 Cool to room temperature and transfer the solution to the ion-exchange column. Place a beaker under the column and open the lower stopcock. When the solution reaches a level 10 mm to 20 mm above the resin bed, rinse the original beaker with 5 mL to 6 mL of HCl (7 + 5) and transfer the rinsings to the column. Repeat this at 2-min intervals until the beaker has been rinsed four times. Wash the upper part of the column with HCl (7 + 5) two times or three times and allow the level to drop to 10 mm to 20 mm above the resin bed each time. Maintain the flow rate at not more than 3.0 mL/min and add HCl (7 + 5) to the column until a total of 175 mL to 185 mL of solution (sample solution and washings) containing mainly chromium, manganese and nickel is collected (Note 7). When the solution in the column reaches a level 10 mm to 20 mm above the resin bed, discard the eluate and then use a 400-mL beaker for the collection of the cobalt eluate.

NOTE 7—To prevent any loss of cobalt, the leading edge of the cobalt band must not be allowed to proceed any farther than 25 mm from the bottom of the resin. Normally, when the cobalt has reached this point in the column, the chromium, manganese, and nickel have been removed.

⁷ Available from the Dow Chemical Co., Midland, MI.

Elution can be stopped at this point, although the total volume collected may be less than 175 mL.

30.4 Add HCl (1 + 2) to the column and collect 165 mL to 175 mL of the solution while maintaining the 3.0-mL/min flow rate. Reserve the solution. If the sample solution did not contain more than 0.200 g of iron, substitute a 250-mL beaker and precondition the column for the next sample as follows: Drain the remaining solution in the column to 10 mm to 20 mm above the resin bed, pass 35 mL to 50 mL of HCl (7 + 5) through the column until 10 mm to 20 mm of the solution remains above the resin bed, then close the lower stopcock. If the sample solution contained more than 0.200 g of iron, or if the column is not to be used again within 3 h, discard the resin and recharge the column as directed in 29.3.

30.5 Add 30 mL of HNO₃ and 15 mL of HClO₄ to the solution from 30.4 and evaporate to fumes of HClO₄. Cool, add 25 mL to 35 mL of water, boil for 1 min to 2 min, cool, and add 10 mL of ammonium citrate solution.

30.6 Using a 50-mL buret, transfer to a 400-mL beaker a sufficient volume of K₃Fe(CN)₆ solution to oxidize the cobalt and to provide an excess of about 5 mL to 8 mL. Record the buret reading to the nearest 0.01 mL. Add 50 mL of NH₄OH and cool to 5 °C to 10 °C. Transfer the beaker to the potentiometric titration apparatus and maintain the 5 °C to 10 °C temperature during the titration.

30.7 While stirring, add the sample solution to the solution from 30.6, rinse the beaker with water, and add the rinsings to the solution (Note 8). Using a 50-mL buret, titrate the excess K₃Fe(CN)₆ with the cobalt solution (1 mL = 1.5 mg Co), at a fairly rapid rate until the end point is approached, and then add the titrant in one-drop increments through the end point. After the addition of each increment, record the buret reading and voltage when equilibrium is reached. Estimate the buret reading at the end point to the nearest 0.01 mL.

NOTE 8—For a successful titration, the sample solution must be added to the excess K₃Fe(CN)₆ solution.

31. Calculation

31.1 Calculate the percent of cobalt as follows:

$$\text{Cobalt, \%} = [(AB - CD)/E] \times 100 \quad (5)$$

where:

- A = standard potassium ferricyanide solution, mL,
- B = cobalt equivalent of the standard potassium ferricyanide solution,
- C = cobalt standard solution, mL,
- D = concentration of cobalt standard solution, mg/mL, and
- E = sample used, mg.

32. Precision and Bias

32.1 *Precision*—Ten laboratories cooperated in testing this test method and obtained the data summarized in Table 3 for Specimens 4 through 8. Although samples covered by this test method with cobalt contents near the lower limit of the scope were not available for testing, the precision data obtained for Specimens 1, 2 and 3 using the test method indicated in Table 3 should apply.

TABLE 3 Statistical Information—Cobalt

Test Specimen	Cobalt Found, %	Repeatability (R ₁ , Practice E173)	Reproducibility (R ₂ , Practice E173)
1. No. 1, Test Methods E352	1.86	0.05	0.12
2. No. 2, Test Methods E352	4.82	0.08	0.11
3. No. 3, Test Methods E352	8.46	0.03	0.07
4. High-temperature alloy 20Cr-13Ni-5Mo-2W-1Cb	11.27	0.06	0.16
5. Ni-base alloy 57Ni-14Cr (NIST 349, 13.95 % Co, certified)	13.88	0.09	0.18
6. High-temperature alloy 21Cr-20Ni-4Mo-3W	19.54	0.08	0.10
7. Co-base alloy 21Ni-20Cr-4Mo-5W-3Cb (NBS, 167, 42.90 % Co, not certified)	42.91	0.18	0.15
8. Co-base alloy 28Cr-6Mo-3Ni	60.10	0.19	0.31

32.2 *Bias*—The bias of this test method may be judged by comparing accepted reference values with the corresponding arithmetic average obtained by interlaboratory testing, such as the data listed in Table 3.

COBALT BY THE NITROSO-R-SALT SPECTROPHOTOMETRIC METHOD

33. Scope

33.1 This test method covers the determination of cobalt from 0.10 % to 5.0 %.

34. Summary of Test Method

34.1 The sample solution is treated with zinc oxide to remove iron, chromium and vanadium. Nitroso-R-salt solution is added to a portion of the filtrate which has been buffered with sodium acetate to produce an orange-colored complex with cobalt. The addition of HNO₃ stabilizes the cobalt complex and also destroys certain interfering complexes. Spectrophotometric measurement is made at approximately 520 nm.

35. Concentration Range

35.1 The recommended concentration range is from 0.005 mg to 0.15 mg of cobalt per 50 mL of solution, using a 1-cm cell.

NOTE 9—This test method has been written for cells having a 1-cm light path. Cells having other dimensions may be used, provided suitable adjustments can be made in the amounts of sample and reagents used.

36. Stability of Color

36.1 The color is stable for at least 3 h.

37. Interferences

37.1 Nickel, manganese and copper form complexes with nitroso-R-salt that deplete the reagent and inhibit the formation of the colored cobalt complex. A sufficient amount of nitroso-R-salt is used to provide full color development with 0.15 mg of cobalt in the presence of 41 mg of nickel, 1.5 mg of manganese, and 5 mg of copper, or 48 mg of nickel only. Colored complexes of nickel, manganese and copper are destroyed by treating the hot solution with HNO₃.

38. Reagents

38.1 *Cobalt, Standard Solution* (1 mL = 0.06 mg Co)—Dry a weighing bottle and stopper in an oven at 130 °C for 1 h, cool in a desiccator, and weigh. Transfer approximately 0.789 g of (CoSO₄)⁶ that has been heated at 550 °C for 1 h to the weighing bottle. Dry the bottle and contents at 130 °C for 1 h, cool in a desiccator, stopper the bottle, and weigh. The difference in weight is the exact amount of CoSO₄ taken. Transfer the weighed CoSO₄ to a 400-mL beaker, rinse the weighing bottle with water and transfer the rinsings to the beaker. Add 150 mL of water and 10 mL of HCl, and heat to dissolve the salts. Cool, transfer to a 500-mL volumetric flask, dilute to volume and mix. By means of a pipet, transfer a 50-mL aliquot of this solution to a 500-mL volumetric flask, dilute to volume and mix. The exact concentration (in mg Co/mL) of the final solution is the exact weight of CoSO₄ taken multiplied by 0.076046.

38.2 *Nitroso-R Salt Solution* (7.5 g/L)—Dissolve 1.50 g of 1-nitroso-2-naphthol-3, 6-disulfonic acid disodium salt (nitroso-R salt) in about 150 mL of water, filter and dilute to 200 mL. This solution is stable for one week.

38.3 *Sodium Acetate Solution* (500 g/L) —Dissolve 500 g of sodium acetate trihydrate (CH₃COONa·3H₂O) in about 600 mL of water, filter and dilute to 1 L.

38.4 *Zinc Oxide Suspension* (166 g/L) —Add 10 g of finely divided zinc oxide (ZnO) to 60 mL of water and shake thoroughly. Prepare fresh daily as needed.

39. Preparation of Calibration Curve

39.1 *Calibration Solutions*—Using pipets, transfer (2, 5, 10, 15, 20, and 25) mL of cobalt standard solution (1 mL = 0.06 mg Co) to six 100-mL volumetric flasks, dilute to volume and mix. Using a pipet, transfer 10 mL of each solution to a 50-mL borosilicate glass volumetric flask. Proceed as directed in 39.3.

39.2 *Reference Solution*—Transfer 10 mL of water to a 50-mL volumetric flask. Proceed as directed in 39.3.

39.3 *Color Development*—Add 5 mL of sodium acetate solution and mix. Using a pipet, add 10 mL of nitroso-R-salt solution and mix. Place the flask in a boiling water bath. After 6 min to 10 min, add 5 mL of HNO₃ (1 + 2) and mix. Continue the heating for 2 min to 4 min. Cool the solution to room temperature, dilute to volume and mix.

39.4 Spectrophotometry:

39.4.1 *Multiple-Cell Spectrophotometer*—Measure the cell correction with water using absorption cells with a 1-cm light path and using a light band centered at approximately 520 nm. Using the test cell, take the spectrophotometric readings of the calibration solutions versus the Reference Solution (39.2).

39.4.2 *Single-Cell Spectrophotometer*—Transfer a suitable portion of the reference solution (39.2) to an absorption cell with a 1-cm light path and adjust the spectrophotometer to the initial setting, using a light band centered at approximately 520 nm. While maintaining this adjustment, take the spectrophotometric readings of the calibration solutions.

39.5 *Calibration Curve*—Follow the instrument manufacturer's instructions for generating the calibration curve

40. Procedure

40.1 Test Solution:

40.1.1 Select and weigh a sample in accordance with the following.

40.1.1.1

Cobalt, %	Sample Weight, g	Tolerance in Sample Weight, mg	Volume of Sample Solution, mL
0.01 to 0.30	0.500	0.2	100
0.25 to 1.00	0.375	0.2	250
0.90 to 3.00	0.125	0.1	250
2.80 to 5.00	0.150	0.1	500

40.1.1.2 Transfer it to a (100, 250, or 500)-mL borosilicate glass volumetric flask.

40.1.2 Add 5 mL of a mixture of one volume of HNO₃ and 3 volumes of HCl. Heat gently until the sample is dissolved. Boil the solution until brown fumes have been expelled. Add 50 mL to 55 mL of water and cool.

NOTE 10—Other ratios and concentrations of acids, with or without the addition of 1 mL to 2 mL of HF, are used for the decomposition of special grades of alloys. If HF is used, the sample should be dissolved in a 150-mL beaker and the solution transferred to the specified volumetric flask.

40.1.3 Add ZnO suspension in portions of about 5 mL until the iron is precipitated and a slight excess of ZnO is present. Shake thoroughly after each addition of the precipitant and avoid a large excess (Note 11). Dilute to volume and mix. Allow the precipitate to settle; filter a portion of the solution through a dry, fine-porosity filter paper, and collect it in a dry, 150-mL beaker after having discarded the first 10 mL to 20 mL. Using a pipet, transfer 10 mL of the filtrate to a 50-mL borosilicate glass volumetric flask. Proceed as directed in 39.3.

NOTE 11—When sufficient ZnO has been added, further addition of the reagent causes the brown precipitate to appear lighter in color upon thorough shaking. A sufficient excess is indicated by a slightly white and milky supernatant liquid.

40.2 *Spectrophotometry*—Take the spectrophotometric reading of the test solution as directed in 39.4.

41. Calculation

41.1 Convert the net spectrophotometric reading of the test solution to milligrams of cobalt by means of the calibration curve. Calculate the percentage of cobalt as follows:

$$\text{Cobalt, \%} = A/(B \times 10) \quad (6)$$

where:

A = cobalt found in 50 mL of the final test solution, mg, and

B = sample represented in 50 mL of the final test solution, g.

42. Precision and Bias

42.1 *Precision*⁸—Eight laboratories cooperated in testing this test method and obtained the data summarized in Table 4

⁸ Supporting data have been filed at ASTM International Headquarters and may be obtained by requesting Research Report RR:E03-1028.

TABLE 4 Statistical Information—Cobalt

Test Specimen	Cobalt Found, %	Repeatability (R_1 , Practice E173)	Reproducibility (R_2 , Practice E173)
1. Ni-base alloy, 36Ni (NIST 126b, 0.032 % Co, certified)	0.032	0.005	0.006
2. No. 2, Test Methods E353	0.094	0.006	0.013
3. No. 3, Test Methods E353	0.173	0.011	0.026
4. Ni-base alloy, 17Cr-15Fe (NIST 161, 0.47 % Co, certified)	0.468	0.020	0.028
5. No. 2, Test Methods E352	1.87	0.09	0.13
6. No. 3, Test Methods E352	4.94	0.08	0.17

for Specimens 1 and 4. Although samples covered by this test method with cobalt content near the extreme limits of the scope were not available for testing, the precision data obtained for other types of alloys, using the test methods indicated in [Table 4](#) should apply.

42.2 *Bias*—The bias of this test method may be judged by comparing accepted reference values with the corresponding arithmetic average obtained by interlaboratory testing, such as the data listed in [Table 4](#).

COPPER BY THE NEOCUPROINE SPECTROPHOTOMETRIC METHOD

43. Scope

43.1 This test method covers the determination of copper from 0.010 % to 1.50 %.

44. Summary of Test Method

44.1 Copper is separated as cuprous copper from other metals by extraction of the copper-neocuproine complex with chloroform. Spectrophotometric measurement is made at approximately 455 nm.

45. Concentration Range

45.1 The recommended concentration range is from 0.01 mg to 0.30 mg of copper per 50 mL of solution, using a 1-cm cell.

NOTE 12—This test method has been written for cells having a 1-cm light path. Cells having other dimensions may be used, provided suitable adjustments can be made in the amounts of sample and reagents used.

46. Stability of Color

46.1 The color develops within 5 min and the extracted complex is stable for at least one week; however, because of the volatile nature of the solvent, it is advisable to take spectrophotometric readings promptly.

47. Interferences

47.1 The elements ordinarily present do not interfere if their contents are under the maximum limits shown in [1.1](#).

48. Reagents

48.1 *Chloroform* (CHCl_3).

48.2 *Citric Acid Solution* (300 g/L)—Dissolve 300 g of citric acid in water and dilute to 1 L. The addition of 1 g of benzoic acid per litre will prevent bacterial growth.

48.3 *Copper, Standard Solution* (1 mL = 0.01 mg Cu)—Transfer 0.4000 g of copper (purity 99.9 % minimum) to a 250-mL Erlenmeyer flask, and dissolve in 20 mL of HNO_3 (1 + 1). Add 10 mL of HClO_4 and evaporate to HClO_4 fumes to expel HNO_3 . Cool, add 100 mL of water, transfer to a 1-L volumetric flask, dilute to volume, and mix. Using a pipet, transfer 25 mL to a 1-L volumetric flask, dilute to volume, and mix. Do not use a solution that has stood more than one week.

48.4 *2,9-Dimethyl-1,10-Phenanthroline (Neocuproine) Solution* (1 g/L)—Dissolve 0.1 g of neocuproine in 100 mL of absolute ethanol.

NOTE 13—In addition to absolute ethanol, 95 % ethanol or denatured ethanol have been found suitable for preparing this solution.

48.5 *Hydroxylamine Hydrochloride Solution* (100 g/L)—hydroxylamine hydrochloride ($\text{NH}_2\text{OH}\cdot\text{HCl}$) in 50 mL of water. Prepare fresh as needed.

49. Preparation of Calibration Curve

49.1 *Calibration Solutions*—Using pipets, transfer (5, 10, 15, 20, 25, and 30) mL of copper solution (1 mL = 0.01 mg Cu) to 150-mL beakers, and dilute to 50 mL. Proceed as directed in [49.3](#).

49.2 *Reagent Blank Solution*—Transfer 50 mL of water to a 150-mL beaker. Proceed as directed in [49.3](#).

49.3 Color Development:

49.3.1 Add 5 mL of $\text{NH}_2\text{OH}\cdot\text{HCl}$ solution and 10 mL of citric acid solution. Stir for 30 s. Using a pH meter ([Note 14](#)), adjust the pH to 5.0 ± 1.0 with NH_4OH (1 + 1). Add 10 mL of neocuproine solution.

NOTE 14—Test paper may be used, except for highly colored solutions, by affixing it to the inner wall of the beaker, and rinsing it with water before removing it.

49.3.2 Transfer the solution to a 125-mL conical separatory funnel, rinsing the beaker with 10 mL to 15 mL of water. Add 15 mL of CHCl_3 and shake for 30 s. Allow the phases to separate. Place a small roll of filter paper which has been washed with CHCl_3 , in the stem of a small funnel. Drain the CHCl_3 layer through the funnel into a 50-mL volumetric flask containing 6 mL to 7 mL of ethanol. Add 10 mL of CHCl_3 to the separatory funnel, extract as before, and drain the CHCl_3 layer through the funnel into the 50-mL volumetric flask. Repeat the extraction just described. Wash the paper and the funnel with 4 mL to 5 mL of ethanol, and collect the washings in the volumetric flask. Dilute to volume with ethanol, and mix.

49.4 *Reference Solution*— CHCl_3 .

49.5 Spectrophotometry:

49.5.1 *Multiple-Cell Spectrophotometer*—Measure the reagent blank (which includes the cell correction) using absorption cells with a 1-cm light path and a light band centered at approximately 455 nm. Using the test cell, take the spectrophotometric readings of the calibration solutions.

49.5.2 *Single-Cell Spectrophotometer*—Transfer a suitable portion of the reference solution to an absorption cell with a 1-cm light path and adjust the spectrophotometer to the initial setting, using a light band centered at approximately 455 nm. While maintaining this adjustment, take the spectrophotometric readings of the calibration solutions.

49.6 *Calibration Curve*—Follow the instrument manufacturer’s instructions for generating the calibration curve.

50. Procedure

50.1 Test Solution:

50.1.1 Select a sample in accordance with the following.

50.1.1.1

Copper, %	Sample Weight, g	Tolerance in Sample Weight, mg	Dilution, mL	Aliquot Volume, mL
0.01 to 0.15	1.00	1.0	100	20
0.10 to 0.25	1.00	1.0	250	30
0.20 to 0.50	1.00	0.5	250	15
0.40 to 1.00	0.50	0.5	250	15
0.80 to 1.50	0.50	0.1	250	10
1.40 to 3.00	1.00	0.1	1000	10
2.80 to 5.00	0.60	0.1	1000	10
4.80 to 7.50	0.80	0.1	1000	5
7.25 to 10.00	0.60	0.1	1000	5

NOTE 15—Some alloys are more readily decomposed by a mixture of 5 mL of bromine, 15 mL of HCl, and one to two drops of HF.

50.1.1.2 Transfer it to a 250-mL Erlenmeyer flask.

50.1.1.3 Add amounts of HCl or HNO₃, or mixtures and dilutions of these acids, which are sufficient to dissolve the sample (Note 15). Heat as required to hasten dissolution. Add HNO₃ to provide an excess of 3 mL to 4 mL, a sufficient amount of HF to volatilize the silica, and 15 mL of HClO₄.

50.1.2 Heat to fumes, and continue fuming until chromium, if present, is oxidized and the white HClO₄ vapors are present only in the neck of the flask. Add, with care, 1.0 mL to 1.5 mL of HCl allowing it to drain down the side of the flask. If there is evidence of the volatilization of chromyl chloride, make repeated additions of HCl, followed by fuming after each addition, until most of the chromium has been removed. Continue fuming the solution until the volume has been reduced to about 10 mL. Cool, add 7 mL of water and digest if necessary to dissolve the salts. Cool to room temperature, add 1 mL of HCl, and transfer the solution (Note 16) to a volumetric flask that provides for the dilution specified in 50.1.1.1. Dilute to volume and mix.

NOTE 16—If silver is present in the alloy it must be removed by filtration at this point.

50.1.3 Allow insoluble matter to settle, or dry-filter through a coarse paper and discard the first 15 mL to 20 mL of the filtrate before taking the aliquot. Using a pipet, transfer a portion as specified in 50.1.1.1 to a 150-mL beaker, and dilute to 50 mL. Proceed as directed in 49.3.

50.2 *Reagent Blank*—Carry a reagent blank through the entire procedure, using the same amounts of all reagents but with the sample omitted.

50.3 *Spectrophotometry*—Take the spectrophotometric reading of the test solution as directed in 49.5.

51. Calculation

51.1 Convert the net spectrophotometric readings of the test solution and of the reagent blank solution to milligrams of copper by means of the calibration curve. Calculate the percentage of copper as follows:

$$\text{Copper, \%} = (A - B)/(C \times 10) \tag{7}$$

where:

- A = copper found in 50 mL of the final test solution, mg,
- B = copper found in 50 mL of the final reagent blank solution, mg, and
- C = sample represented in 50 mL of the final test solution, g.

52. Precision and Bias

52.1 *Precision*—Ten laboratories cooperated in testing this test method and obtained the data summarized in Table 5. Although samples only in the lower part of the scope of this test method were available for testing, the precision data obtained for specimens in the remainder of the scope using the test methods indicated should apply.

52.2 *Bias*—The bias of this test method may be judged by comparing accepted reference values with the corresponding arithmetic average obtained by interlaboratory testing, such as the data listed in Table 5.

TOTAL ALUMINUM BY THE 8-QUINOLINOL GRAVIMETRIC METHOD

53. Scope

53.1 This test method covers the determination of total aluminum from 0.20 % to 7.00 %.

54. Summary of Test Method

54.1 Following dissolution, acid-insoluble aluminum is separated, fused and recombined. Interfering elements are removed by mercury-cathode, cupferron and sodium hydroxide separations. Aluminum quinolate is precipitated and weighed.

TABLE 5 Statistical Information—Copper

Test Specimen	Copper Found, %	Repeat-ability, (R ₁ , Practice E173)	Reproduc-ibility, (R ₂ , Practice E173)
1. Nickel-base alloy, 57Ni-14Cr (NIST 349, 0.006 % Cu, certified)	0.006	0.001	0.004
2. Nickel-base alloy, 77Ni-20Cr (NIST 169, 0.015 % Cu, certified)	0.014	0.002	0.006
3. Cobalt-base alloy 41Co-20Ni (NIST 168, 0.035 % Cu, not certified)	0.033	0.005	0.004
4. No. 5, Test Methods E352	0.078	0.005	0.010
5. No. 6, Test Methods E352	0.118	0.007	0.016
6. No. 6, Test Methods E353	0.176	0.019	0.021
7. No. 7, Test Methods E353	0.200	0.012	0.018
8. No. 8, Test Methods E353	0.221	0.013	0.022
9. No. 9, Test Methods E353	0.361	0.015	0.036
10. No. 5, Test Methods E351	1.51	0.04	0.05
11. No. 6, Test Methods E351	5.53	0.19	0.18

55. Interferences

55.1 The elements ordinarily present do not interfere if their amounts are under the maximum limits shown in 1.1.

56. Apparatus

56.1 *Filtering Crucible*, medium-porosity fritted-glass, low form, 30-mL capacity.

56.2 *Glassware*, to prevent contamination of the sample, all glassware must be cleaned with hot HCl (1 + 1) before use.

56.3 *HCl Gas Generator* (Fig. 2)—A simple HCl gas generator constructed from a stoppered wash bottle and glass tubing.

56.4 *Mercury Cathode*—An efficient apparatus for mercury cathode separations is that employing a rotating mercury pool cathode. With this instrument the movement of the cathode causes a fresh surface of mercury to be exposed during electrolysis, thus accelerating the separation. This instrument permits use of a current of 15 A in a 400-mL beaker. The electrolyte may be removed from the cell through a stopcock located just above the level of the mercury or siphoned from it. When 1% or more of aluminum or titanium is present and these are to be determined, it should be initially ascertained if any of the aluminum or titanium is lost to the cathode.

56.5 *pH Meter*.

57. Reagents

57.1 *Ammonium Peroxydisulfate Solution* (100 g/L)—Dissolve 20 g of ammonium peroxydisulfate ((NH₄)₂S₂O₈) in water and dilute to 200 mL. Do not use a solution that has stood more than 8 h.

57.2 *Chloroform* (CHCl₃).

57.3 *Cupferron Solution* (60 g/L) —Dissolve 6 g of cupferron in 80 mL of cold water, dilute to 100 mL and filter. Prepare fresh as needed. (**Warning**—Cupferron is a known carcinogen. Use protective equipment and work in an efficient exhaust hood.)

57.4 *8-Quinolinol Solution* (25 g/L) —Dissolve 25 g of 8-quinolinol in 50 mL of acetic acid, dilute to 300 mL with warm water, filter through a medium paper and dilute to 1 L. Store in an amber bottle away from direct sunlight. Do not use a solution that has stood more than one month.

57.5 *Sodium Hydrogen Sulfate, Fused* (a mixture of Na₃S₂O₇ and NaHSO₄).

57.6 *Sodium Hydroxide Solution* (200 g/L) —Dissolve 100 g of NaOH in water in a platinum dish or in a plastic beaker, and dilute to 500 mL. Store in a polyethylene bottle.

57.7 *Tartaric Acid Solution* (200 g/L) —Dissolve 200 g of C₄H₆O₆ in 500 mL of water, filter through a medium paper and dilute to 1 L.

58. Procedure

58.1 Transfer a 1.000-g sample, weighed to the nearest 0.1 mg, to a 600-mL beaker.

58.2 Carry a reagent blank through the entire procedure, using the same amounts of all reagents but with the sample omitted.

58.3 Add 30 mL of HCl and 10 mL of HNO₃ and digest at a low temperature until dissolution is complete. Add 30 mL of HClO₄, heat to fumes and continue fuming until chromium, if present, is oxidized. If chromium is present, position the gas generator containing boiling HCl (use a fresh portion of HCl for each sample), so that the tube extends into the beaker and the HCl gas is delivered 20 mm to 30 mm above the surface of the fuming HClO₄. Continue boiling the HCl and fuming the sample solution until there is no evidence of yellow chromyl chloride in the fumes. Remove the generator and continue fuming the solution until the volume is reduced to 10 mL. Remove from the hot plate and cool. Add 25 mL of water to dissolve the salts. If iron hydrolyzes, indicating that the sample was fumed too long, add 1 mL to 2 mL of HCl and 5 mL HClO₄ and again take to fumes. Dilute to 75 mL with water and boil to remove chlorine.

58.4 Filter through an 11-cm medium paper into a 400-mL beaker. Scrub and wipe the inside of the beaker with half a sheet of filter paper. Add this paper to the funnel. Wash the original beaker, the paper, and the residue two or three times with hot HClO₄ (2 + 98) and then three or four times with hot water to ensure removal of HClO₄. Reserve the filtrate.

58.5 Transfer the paper to a platinum crucible, dry it and then heat at about 600 °C until the carbon has been removed. Finally ignite at 1100 °C, cool and add a few drops of H₂SO₄ (1 + 1) and 4 mL to 5 mL of HF. Evaporate to dryness and heat at a gradually increasing rate until the H₂SO₄ has been removed. Cool, add 2 g to 3 g of sodium hydrogen sulfate fused, and heat until a clear melt is obtained. Cool the crucible, transfer it to a 250-mL beaker, add 50 mL of water and then digest until the melt is dissolved. Remove and rinse the crucible with water.

58.6 If the solution is clear, add it to the filtrate reserved in 58.4. If the solution is turbid, filter through an 11-cm fine paper containing paper pulp into the beaker containing the reserved filtrate. Wash the paper three to four times with hot H₂SO₄ (3 + 97). Discard the paper and residue.

58.7 Evaporate to approximately 100 mL and cool. Transfer the solution to a mercury cathode cell. Dilute to 150 mL to 200 mL and electrolyze at 15 A (Note 17) until the iron has been removed (Note 18). Without interrupting the current, transfer the solution from the cell to a 400-mL beaker.

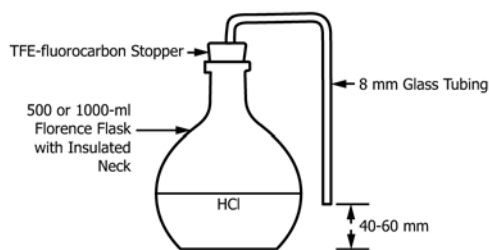

FIG. 2 HCl Gas Generator

Thoroughly rinse the cell and electrodes several times with water and add the rinsings to the solution.

NOTE 17—Contact between the mercury pool and the platinum cathode may be broken intermittently due to stirring the mercury too rapidly. Since this will cause arcing which will result in the dissolution of some mercury in the electrolyte, it should be avoided by adding more mercury to the cell, using less current or by proper adjustment of the cathode lead wire so that contact will be ensured.

NOTE 18—The completeness of the removal of iron, which usually requires 1 h to 3 h, can be determined by the following test: Transfer one drop of the electrolyte to a watchglass or spot test plate. Add one drop of H₂SO₄ (1 + 1), one drop of saturated potassium permanganate (KMnO₄) solution and one drop of sodium thiocyanate (NaSCN) solution (500 g/L). When only a faint pink color is observed, the electrolysis may be considered complete.

58.8 Filter the solution through a 12.5-cm medium paper containing paper pulp (Note 19) into a 600-mL beaker and wash three or four times with hot water. To the filtrate add 10 mL of H₂SO₄ (1 + 1) and 10 mL of (NH₄)₂S₂O₈ solution. Heat to boiling and evaporate to about 75 mL. Cool in an ice bath to below 10 °C.

NOTE 19—This filtration removes any mercurous chloride that may have formed and any metallic mercury that may have been transferred from the cell.

58.9 Transfer the solution to a 250-mL conical separatory funnel and, without delay, add 15 mL of cupferron solution. Reserve the beaker. Shake for 30 s and allow the precipitate to settle. Add 20 mL of CHCl₃ and shake for 1 min. Allow the layers to separate. Draw off and discard the CHCl₃ layer. Repeat the extraction with 20-mL portions of CHCl₃ until the extract is colorless. Transfer the aqueous solution to the reserved 600-mL beaker and evaporate to 35 mL to 40 mL. Add 25 mL of HNO₃, cover with a ribbed cover glass, evaporate to fumes of H₂SO₄ and cool. Dilute to 50 mL, heat to boiling and cool.

58.10 Transfer the solution to a platinum, quartz or high-silica glass or polytetrafluoroethylene beaker. Police thoroughly (Note 20), rinse the beaker and add the rinsings to the main solution. Neutralize to litmus with NaOH solution (Note 21) and add a 10-mL excess. Add 1 mL of H₂O₂, digest near the boiling point for 5 min to 7 min and finally boil for 1 min to 2 min to coagulate the manganese precipitate. Cool and filter through a 12.5-cm medium paper containing paper pulp previously washed three times with hot dilute NaOH solution (20 g/L) into a 600-mL beaker. Wash the paper and precipitate four times or five times with hot water. Immediately add HCl (1 + 1) to the filtrate until acidic to litmus paper and then add 3 mL to 4 mL in excess.

NOTE 20—This step is necessary whether or not a precipitate is visible.

NOTE 21—Approximately 70 mL will be required.

58.11 If the aluminum content is less than 1.50 %, proceed as directed in 58.12 – 58.14.

58.12 Dilute to approximately 250 mL and add 25 mL of tartaric acid solution. Using a pH meter, adjust the pH to 8.0 with NH₄OH.

58.13 Add 10 mL of H₂O₂ (Note 22) heat to 55 °C and while stirring, add 15 mL of 8-quinolinol solution. Add 5 mL of NH₄OH and stir continuously for 1 min and then for 5 s to

10 s once a min for 9 min more while maintaining the temperature at 50 °C to 55 °C.

NOTE 22—Precipitate aluminum in only one sample at a time. A motor-driven stirrer operating continuously for 10 min may be used.

58.14 Allow the solution to cool to room temperature. Filter with suction, using a weighed, medium-porosity, fritted-glass crucible. Police the beaker, rinse with NH₄OH (1 + 100) and wash the precipitate four times with warm NH₄OH (1 + 100). Dry for 1.5 h at 135 °C, cool and weigh as aluminum quinolate.

58.15 If the aluminum content is greater than 1.50 %, transfer the solution to a 250-mL volumetric flask, dilute to volume and mix. Select the proper aliquot in accordance with 58.15.1.

58.15.1

Aluminum, %	Aliquot, mL	Weight of Sample in Aliquot, g
1.50 to 3.50	100	0.400
3.50 to 7.00	50	0.200

58.15.2 Using a pipet, transfer it to a 600-mL beaker. Proceed as directed in 58.12 – 58.14.

59. Calculation

59.1 Calculate the percent of total aluminum as follows:

$$\text{Total aluminum, \%} = [(A - B) \times 0.0587] / C \times 100 \quad (8)$$

where:

A = aluminum quinolate found, g,

B = correction for blank, g, and

C = sample in final aliquot, g.

60. Precision and Bias

60.1 *Precision*—Eight laboratories cooperated in testing this test method using Test Specimens 3 and 6, nine using Test Specimens 4 and 5, with one laboratory reporting a second pair of values in each instance; the data are summarized in Table 6. Although samples covered by this test method with aluminum contents at the upper limit and at the lower limit of the scope were not available for testing, the precision data obtained using the test methods indicated in Table 6 should apply.

60.2 *Bias*—The bias of this test method may be judged by comparing accepted reference values with the corresponding arithmetic average obtained by interlaboratory testing, such as the data listed in Table 6.

TABLE 6 Statistical Information—Aluminum

Test Specimen	Aluminum Found, %	Repeatability (R ₁ , Practice E173)	Reproducibility (R ₂ , Practice E173)
1. No. 1, Test Methods E353	0.232	0.036	0.041
2. No. 2, Test Methods E353	1.16	0.06	0.10
3. Nickel-base alloy 57Ni-14Cr (NIST 349, 1.23 % Al, certified)	1.21	0.02	0.08
4. No. 4, Test Methods E350	1.44	0.07	0.16
5. Nickel-base alloy 19Cr-19Co-4Mo-3Ti	2.88	0.06	0.12
6. Nickel-base alloy 13Cr-4.5Mo-2.2Cb	5.84	0.16	0.26

NICKEL BY THE DIMETHYLGLYOXIME GRAVIMETRIC METHOD

61. Scope

61.1 This test method covers the determination of nickel from 0.1 % to 84.0 %.

62. Summary of Test Method

62.1 Nickel dimethylglyoximate is precipitated by adding an alcoholic solution of dimethylglyoxime to a solution of the sample containing ammonium citrate. A second precipitation is performed to purify the precipitate prior to drying and weighing.

62.2 Alternatively, nickel and manganese are separated from the other alloying elements by anion exchange in HCl to eliminate the need for the first precipitation with dimethylglyoxime. This separation must be used when cobalt is present in amounts greater than 0.5 % and may be used for all other samples. Nickel dimethylglyoximate is precipitated by adding dimethylglyoxime to the eluate; the precipitate is filtered, dried and weighed.

63. Interferences

63.1 Cobalt, copper and manganese are present in the divalent state and consume dimethylglyoxime, making it necessary to add an excess of the precipitant over that required to precipitate nickel. When the anion-exchange separation is used, manganese is present in the solution from which nickel is precipitated and an excess of the precipitant is required.

64. Apparatus

64.1 *Anion-Exchange Column*, approximately 25 mm in diameter and 300 mm in length, tapered at one end, and provided with a stopcock to control the flow rate and a second, lower stopcock to stop the flow. A reservoir for the eluants may be added at the top of the column.

64.2 *Filtering Crucibles*, fritted glass, 30-mL capacity, medium porosity.

64.3 *pH Meter*.

65. Reagents

65.1 *Ammonium Citrate Solution* (200 g/L)—Dissolve 20 g of diammonium hydrogen citrate ((NH₄)₂HC₆H₅O₇) in 600 mL of water. Filter and dilute to 1 L.

65.2 *Anion Exchange Resin*:

65.2.1 Use an anion exchange resin of the alkyl quaternary ammonium type (chloride form) consisting of spherical beads having a crosslinkage of 8 % and a (200 to 400) nominal mesh size.⁹ To remove those beads greater than 180 μm in diameter as well as the excessively fine beads, treat the resin as follows: Transfer a supply of the resin to a beaker, cover with water and allow sufficient time (at least 30 min) for the beads to undergo maximum swelling. Place a No. 80 (180-μm) screen, 150 mm in diameter over a 2-L beaker. Prepare a thin slurry of the resin

and pour it onto the screen. Wash the fine beads through the screen using a small stream of water. Discard the beads retained on the screen periodically, if necessary, to avoid undue clogging of the openings. When the bulk of the collected resin has settled, decant the water and transfer approximately 100 mL of resin to a 400-mL beaker. Add 200 mL of HCl (1 + 19), stir vigorously, allow the resin to settle for 4 min to 6 min, decant 150 mL to 175 mL of the suspension and discard. Repeat the treatment with HCl (1 + 19) twice more and reserve the coarser resin for the column preparation.

65.2.2 Prepare the column as follows: Place a 10-mm to 20-mm layer of glass wool or polyvinyl chloride plastic fiber in the bottom of the column and add a sufficient amount of the prepared resin to fill the column to a height of approximately 140 mm. Place a 20-mm layer of glass wool or polyvinyl chloride plastic fiber at the top of the resin bed to protect it from being carried into suspension when the solutions are added. While passing a minimum of 100 mL of HCl (3 + 1) through the column with the hydrostatic head 100 mm above the top of the resin bed, adjust the flow rate to not more than 3.0 mL/min. Drain 10 mm to 20 mm above the top of the resin bed and then close the lower stopcock.

65.3 *Dimethylglyoxime Solution in Alcohol* (10 g/L)—Dissolve 10 g of dimethylglyoxime in ethanol, methanol or denatured ethanol and dilute to 1 L with alcohol. Filter before using. This solution keeps almost indefinitely.

66. Procedure

66.1 *Double Precipitation*:

66.1.1 Select and weigh a sample in accordance with the following.

66.1.1.1

Nickel, %	Sample Weight, g	Tolerance Sample Weight, mg
0.1 to 1.0	3.0	1.0
1.0 to 5.0	1.0	0.5
5.0 to 10.0	0.5	0.2
10.0 to 20.0	0.25	0.1
20.0 to 48.0	1.0	0.5
48.0 to 84.0	0.5	0.2

66.1.1.2 Transfer it to a 600-mL beaker.

66.1.2 Add 60 mL of HCl (1 + 1) and 10 mL of HNO₃. Heat to dissolve the sample and boil to expel oxides of nitrogen. Cool the solution and add 30 mL of HClO₄. Heat to strong fumes of HClO₄ and continue fuming for 5 min. Cool and dilute to 100 mL with water.

66.1.3 Filter the solution through an 11-cm coarse paper into a 600-mL beaker. Transfer any insoluble matter to the paper with hot HCl (5 + 95). Wash the beaker and paper alternately with hot HCl (5 + 95) and hot water until iron salts are removed. Finally, wash the paper three times with 5-mL portions of hot water. Discard the residue. If the nickel content is greater than 20 %, transfer the filtrate from the beaker to a 200-mL volumetric flask, dilute to volume, and mix. Using a pipet, transfer a 20-mL aliquot to a 600-mL beaker and add 10 mL of HCl.

66.1.4 Add 200 mL of water and 20 mL of ammonium citrate solution. Using a pH meter, adjust the pH to at least 7.5 with NH₄OH. Acidify the solution with HCl to pH 6.3 ± 0.1.

⁹ Dowex 1, manufactured by the Dow Chemical Co., Midland, MI, has been found satisfactory for this purpose.

66.1.5 Add 10 mL of the dimethylglyoxime solution plus an additional 0.4 mL for each milligram of nickel, manganese, cobalt and copper present.

66.1.6 Using a pH meter, adjust the pH to 7.4 ± 0.1 with NH_4OH . Remove the electrode and rinse with water. Heat at $50\text{ }^\circ\text{C}$ to $70\text{ }^\circ\text{C}$ for 30 min. Let stand for at least 4 h at $20\text{ }^\circ\text{C}$ to $25\text{ }^\circ\text{C}$.

66.1.7 Filter using a 12.5-cm coarse paper. Wash five times to seven times with cold water. Transfer the paper and precipitate to the original beaker. Moisten a small piece of filter paper, use it to remove any precipitate adhering to the funnel, and place it in the original beaker.

66.1.8 Add 30 mL of HNO_3 and 15 mL of HClO_4 . Evaporate to strong fumes and continue fuming for 5 min. Cool and add 50 mL of water.

66.1.9 Filter through an 11-cm coarse paper into a 600-mL beaker. Wash the paper five times with HCl (5 + 95) and three times with water. Dilute the filtrate to 200 mL with water and proceed as directed in 66.3 – 66.7.

66.2 Anion-Exchange Separation:

66.2.1 Proceed as directed in 66.1.1.

66.2.2 Proceed as directed in 66.1.2, but dilute with only 50 mL of water.

66.2.3 Filter the solution obtained in 66.2.2 through an 11-cm coarse paper, collecting the filtrate in a 250-mL beaker. Transfer any insoluble matter to the paper with hot HCl (5 + 95). Wash the paper alternately with hot water and hot HCl (5 + 95) until iron salts are removed. Finally, wash the paper three times with 5-mL portions of hot water. Discard the residue.

66.2.4 Carefully evaporate to dryness at moderate heat to avoid spattering. Cool, add 10 mL of HCl and evaporate to dryness. Cool, add 20 mL of HCl (3 + 1) and heat, if necessary, to dissolve salts but avoid loss of HCl by overheating or prolonged heating.

66.2.5 Precondition the ion-exchange column with 50 mL of HCl (3 + 1) and adjust the flow rate by means of the upper stopcock to not more than 3.0 mL/min. Allow the acid to drain to 10 mm to 20 mm from the top of the resin bed.

66.2.6 Place a clean 600-mL beaker under the ion-exchange column and open the bottom stopcock. Transfer the solution from 66.2.4 to the column. Allow the sample to drain to 5 mm to 10 mm from the top of the resin bed. Rinse the 250-mL beaker with a 5-mL portion of HCl (3 + 1) and transfer the rinsing to the column. When it has drained to 5 mm to 10 mm above the resin bed, add a second 5-mL rinse portion from the 250-mL beaker. Repeat this operation three more times and allow the level to drop to 5 mm to 10 mm above the resin bed before adding the next. Add sufficient HCl (3 + 1) at the top of the column to collect a total of 200 mL in the 600-mL beaker. Close the lower stopcock and reserve the solution.

66.2.7 Precondition the column for the next sample as follows: Open the lower stopcock. Drain any remaining solution in the column to 5 mm to 10 mm from the top of the resin bed. Add HCl (1 + 19) in 50-mL increments until iron has been eluted and the eluate is visibly free of color (approximately 300 mL). Drain the solution to 5 mm to 10 mm from the top of the resin bed and close the lower stopcock. If the column is not

to be used immediately, cover and store. If another sample solution is to be put through the column, proceed as directed in 66.2.5.

66.2.8 Heat the solution reserved in 66.2.6 to boiling and evaporate to 60 mL to remove excess HCl. If the sample contains less than 20 % nickel, cool and dilute to 200 mL. If the sample contains more than 20 % nickel, cool and transfer to a 200-mL volumetric flask. Add 20 mL of HCl, dilute to volume, and mix. Using a pipet, transfer a 20-mL aliquot to a 600-mL beaker, and dilute to 200 mL with water.

66.3 Add 10 mL of ammonium citrate solution and 10 mL of HCl. Using a pH meter, adjust the pH to at least 7.5 with NH_4OH . Remove and rinse the electrode with water, collecting the rinsings in the original beaker.

66.4 Add 2 mL of HCl and, while stirring the solution, add 10 mL of dimethylglyoxime solution plus an additional 0.4 mL for each milligram of nickel present. If the separation was made by anion-exchange, add an additional 0.4 mL for each milligram of manganese present.

66.5 Using a pH meter, adjust the pH to 7.4 ± 0.1 with NH_4OH . Remove and rinse the electrodes with water. Heat at $50\text{ }^\circ\text{C}$ to $70\text{ }^\circ\text{C}$ for 30 min and allow to stand for at least 4 h at $20\text{ }^\circ\text{C}$ to $25\text{ }^\circ\text{C}$.

66.6 With the aid of suction, filter using a weighed fritted glass crucible, wash the beaker and precipitate six times with cold water. Heat the crucible at $150\text{ }^\circ\text{C}$ and cool in a desiccator before weighing.

66.7 Dry at $150\text{ }^\circ\text{C}$ at least 3 h to constant weight. Cool in a desiccator and weigh.

67. Calculation

67.1 Calculate the percent of nickel as follows:

$$\text{Nickel, \%} = [(A - B) \times 0.2032] / C \times 100 \quad (9)$$

where:

A = weight of crucible and precipitate, g,

B = weight of crucible, g, and

C = sample represented in the final test solution, g.

68. Precision and Bias

68.1 Precision—Ten laboratories cooperated in the testing of this test method and obtained the data summarized in Table 7. Although a sample covered by this test method near the

TABLE 7 Statistical Information—Nickel

Test Specimen	Nickel Found, %	Repeatability (R_1 , Practice E173)	Reproducibility (R_2 , Practice E173)
1. No. 1, Test Methods E352	0.135	0.012	0.015
2. No. 2, Test Methods E353	1.81	0.09	0.09
3. Nickel-chrome steel 16 Cr-4 Ni-3 Cu (NIST 345, 4.24 % Ni, certified)	4.22	0.06	0.06
4. Cobalt alloy 41 Co-20 Ni-20 Cr-4 Mo-4W (NIST 168, 20.25 % Ni, not certified)	20.26	0.23	0.23
5. Nickel alloy 77 Ni-20 Cr (NIST 169, 77.26 % Ni, certified)	77.13	0.56	0.56

lower end of the scope was not tested, the data obtained for other types of alloys using the test methods indicated in [Table 7](#) should apply.

68.2 *Bias*—The bias of this test method may be judged by comparing accepted reference values with the corresponding arithmetic average obtained by interlaboratory testing, such as the data listed in [Table 7](#).

TIN BY THE SOLVENT EXTRACTION ATOMIC-ABSORPTION METHOD

69. Scope

69.1 This test method covers the determination of tin in the range from 0.002 % to 0.10 %.

70. Summary of Test Method

70.1 Tin is extracted from a dilute HCl solution of the sample, containing ascorbic acid and potassium iodide, into a solution of trioctylphosphine oxide (TOPO) in methyl isobutyl ketone (MIBK). The MIBK extract is aspirated into the nitrous oxide-acetylene flame. Spectral energy at 286.3 nm from a tin hollow-cathode lamp or tin electrodeless discharge lamp is passed through the flame and the absorbance is measured.

71. Concentration Range

71.1 The recommended concentration range is from 4 µg to 40 µg of tin per millilitre in the final 10 mL of TOPO-MIBK extract.

72. Interferences

72.1 Copper, when present above 0.1 g, interferes by precipitating as cuprous iodide (CuI). This interference may be eliminated by incorporating a suitable copper separation scheme into the procedure prior to the solvent extraction step.

73. Apparatus

73.1 *Atomic Absorption Spectrometer*, capable of resolving the 286.3 nm line, equipped with a tin hollow-cathode lamp or tin electrodeless discharge lamp whose radiant energy is modulated, with a detector system tuned to the same frequency and a premix nitrous oxide-acetylene burner. The performance of the instrument must be such that the upper limit of the concentration range (40 µg/mL) produces an absorbance of 0.15 or higher, and a calibration curve whose deviation from linearity is within the limits specified in [75.4](#).

74. Reagents

74.1 Ascorbic Acid.

74.2 *Iodide-Ascorbic Acid Solution*—Dissolve 30 g of potassium iodide and 10 g of ascorbic acid in 60 mL of HCl (1 + 5). Dilute to 100 mL with water and mix. Do not use a solution that has stood more than one day.

74.3 Methyl Isobutyl Ketone (MIBK).

74.4 *Tin, Standard Solution A* (1 mL = 1.0 mg Sn)—Dissolve 1.000 g of tin (purity 99.9 % minimum) in 100 mL of HCl. Cool, transfer to a 1-L volumetric flask, dilute to volume with HCl (1 + 2), and mix.

74.5 *Tin, Standard Solution B* (1 mL = 50.0 µg Sn)—Using a pipet, transfer a 10-mL aliquot of Solution A to a 200-mL volumetric flask. Dilute to volume with HCl (1 + 2) and mix.

74.6 *Trioctylphosphine Oxide (TOPO-MIBK) Solution* (50 g/L)—Transfer 12.5 g of TOPO to a 250-mL volumetric flask. Dilute to volume with MIBK and mix until dissolution is complete.

75. Preparation of Calibration Curve

75.1 *Calibration Solutions*—Using pipets, transfer (0, 1, 2, 4, 6, and 8) mL of Solution B (1 mL = 50 µg Sn) to 100-mL volumetric flasks. Volumetric flasks with ground glass stoppers must be used.

75.2 Extraction:

75.2.1 Add 15 mL of HCl (1 + 1), 3 g of ascorbic acid and mix. Add 15 mL of iodide-ascorbic acid solution, adjust the volume to approximately 50 mL and mix.

75.2.2 Using a pipet, add 10.0 mL of TOPO-MIBK solution, stopper the flask, invert and shake vigorously several times for a period of 1 min. Allow the phases to separate. Add water to bring the entire organic layer up into the neck portion of the flask. Stopper, invert several times and allow the phases to separate. Prepare the test solution and have it ready to aspirate immediately after aspirating the calibration solutions.

75.3 Spectrophotometry:

75.3.1 With a tin hollow-cathode lamp or electrodeless discharge lamp in position, energized and stabilized, adjust the wavelength setting to the location that gives the maximum detector response in the immediate vicinity of 286.3 nm.

75.3.2 Following the instrument manufacturer's specific directions, ignite the burner using the air-acetylene mode of operation. Immediately after ignition, switch over to the nitrous oxide-acetylene mode of operation and allow the burner to reach thermal equilibrium while aspirating water. Cautiously adjust the height of the red cone of the flame to approximately 12 mm by adjusting the fuel flow. Adjust the detector response to zero while aspirating water. Aspirate Solution B (1 mL = 50 µg Sn) and adjust the height of the burner to obtain maximum response from the detector system. Remove the capillary from the solution and allow air to aspirate for 15 s to 30 s. Aspirate MIBK for 3 s, then readjust the detector response to zero, if necessary.

75.3.3 From this point on, only MIBK solutions should be aspirated until all test and calibration solution measurements have been completed. If the burner slot shows any sign of blockage, shut off the flame according to the instrument manufacturer's approved procedures, clean the slot, and relight as in [75.3.2](#).

75.3.4 Aspirate the solution with the highest concentration (40 µg Sn/mL) from the series prepared in [75.1](#) a sufficient number of times to establish that the absorbance is not drifting. Ensure that the capillary end does not enter the aqueous (bottom) layer at any time. Due to the small amount of extract available for making this test, the number of readings and the time between readings must be kept to a minimum.

75.3.5 Beginning with the calibration solution to which no tin was added, aspirate each calibration solution in turn and

record its absorbance. If the value for the solution with the highest concentration (40 µg Sn/mL) differs from the average values obtained in 75.3.4 by more than 0.03 multiplied by the average of the values, repeat the measurement. If this value indicates a trend or drift, determine the cause (for example, deposit in the burner or clogged capillary), correct it, and repeat the procedure in 75.3.1 – 75.3.5.

75.3.6 Proceed immediately as directed in 76.3.

75.4 *Calibration Curve*—Follow the instrument manufacturer’s instructions for generating the calibration curve. Calculate the deviation from linearity of the curve as follows:

$$\text{Deviation from linearity} = (A - B)/C \quad (10)$$

where:

- A = absorbance value for 40 µg Sn/mL,
- B = absorbance value for 30 µg Sn/mL, and
- C = absorbance value for 10 µg Sn/mL.

If the calculated value is less than 0.60, correct the indicated malfunction or maladjustment of the instrument or lamp and repeat the calibration.

76. Procedure

76.1 *Reagent Blank*—Carry a reagent blank through the entire procedure using the same amount of all reagents with the sample omitted.

76.2 *Test Solution*:

76.2.1 Select and weigh a sample (Note 23) to the nearest 0.5 mg in accordance with the following:

76.2.1.1

Tin, %	Sample Weight, g
0.002 to 0.005	3.00
0.004 to 0.010	2.00
0.009 to 0.050	1.00
0.045 to 0.100	0.50

76.2.1.2 Transfer it to a 400-mL polytetrafluoroethylene beaker.

NOTE 23—Select a sample that will pass through a No. 20 (850-µm) sieve.

76.2.2 Add 100 mL of HCl, 20 drops of 30 % H₂O₂ and 5 drops of HF. Cover the beaker with a polytetrafluoroethylene cover and heat at a low temperature (approximately 90 °C). At 20-min intervals, remove the cover with platinum-tipped tongs and cautiously add an additional 20 drops of 30 % H₂O₂. Repeat this step until dissolution is complete. If silicon is above 0.5 %, use ten drops to twelve drops of HF. If dissolution is very slow, add an additional 50 mL of HCl and heat at approximately 90 °C overnight.

76.2.3 Remove the cover with platinum-tipped tongs and cautiously rinse into the beaker with water. Cautiously evaporate the solution at a low temperature (approximately 90 °C) to 15 mL. Rinse the sides of the beaker with water, add 20 mL of HCl (1 + 1), and again evaporate to 15 mL. Rinse the sides of the beaker with about 5 mL of water and cool.

NOTE 24—If niobium, tantalum, tungsten or certain other elements are present in sufficiently high amounts, they will precipitate. Extract such samples as directed with minimal delay.

76.2.4 Add 3 g of ascorbic acid for a 1-g sample, plus 2 g of ascorbic acid for each additional 1 g of sample. Swirl to dissolve. Add 15 mL of the iodide-ascorbic acid solution.

76.2.5 Transfer the sample to a 100-mL volumetric flask and adjust the volume to approximately 50 mL with water. Using a pipet, transfer 10 mL of the TOPO-MIBK solution to the flask, stopper, invert and shake vigorously several times for one min.

76.2.6 Allow the phases to separate. Add water to bring the entire organic layer into the neck of the flask. Stopper, invert several times, and allow the phases to separate.

76.3 *Spectrophotometry*—Aspirate the top (MIBK) phase of the test solution and the reagent blank solution and record the absorbance values. Ensure that the capillary end does not enter the aqueous (bottom) layer at any time. Take three readings on each solution. Due to the small amount of extract available for conducting this test, the number of readings and the time between readings must be kept to a minimum. Measure the absorbance of the calibration solution with the highest concentration of tin to check for drift as in 75.3.5.

77. Calculation

77.1 Convert the average absorbance of the test and the reagent blank solutions to micrograms of tin per millilitre of the final solution by means of the calibration curve. Calculate the percent of tin as follows:

$$\text{Tin, \%} = [(D - E)/(F \times 1000)] \quad (11)$$

where:

- D = tin per mL of the final test solution, µg,
- E = tin per mL of the final reagent blank solution, µg, and
- F = sample used, g.

78. Precision and Bias¹⁰

78.1 *Precision*—Eleven laboratories cooperated in testing this test method and obtained the precision listed for No. 1, 2, 4 and 6 in Table 8. This test method differs only slightly from the test method for tin, Test Methods E350, in that the reagents used for sample dissolution were slightly modified. The fact that the precision obtained for No. 2, 4 and 6 of Table 8, corresponds closely to that obtained for samples of similar tin

¹⁰ Supporting data have been filed at ASTM International Headquarters and may be obtained by requesting Research Report RR:E03-1022.

TABLE 8 Statistical Information—Tin

Test Specimen	Tin Found, %	Repeat-ability (R ₁ , Practice E173)	Repro-ducibility (R ₂ , Practice E173)
1. Cobalt-alloy (49 Co-balance Fe), 0.001 % Sn (not certified)	0.0017	0.0002	0.0004
2. Nickel-base alloy (74 Ni-15 Cr), 0.002 % Sn (not certified)	0.0021	0.0005	0.0006
3. No. 1, Test Methods E350	0.0034	0.0009	0.0014
4. Nickel-base alloy (74 Ni-15 Cr), 0.008 % Sn (not certified)	0.0076	0.0013	0.0017
5. No. 2, Test Methods E350	0.0079	0.0009	0.0014
6. Nickel-base alloy (74 Ni-15 Cr), 0.017 % Sn (not certified)	0.015	0.002	0.003
7. No. 4, Test Methods E350	0.031	0.003	0.004
8. No. 6, Test Methods E350	0.097	0.011	0.011

content in Test Methods [E350](#), suggests that the precision of the two test methods is the same.

78.2 *Bias*—No information on the accuracy of this test method is available. The accuracy of a test method may be judged, however, by comparing accepted reference values with the arithmetic average obtained by interlaboratory testing. The values listed for these samples, while not certified, were obtained by other test methods and are believed to be substantially correct.

MOLYBDENUM BY THE SPECTROPHOTOMETRIC METHOD

79. Scope

79.1 This test method covers the determination of molybdenum from 0.01 % to 1.50 %.

80. Summary of Test Method

80.1 The test solution is treated with thiocyanate to develop the molybdenum and iron thiocyanate complexes. Molybdenum and iron are reduced with stannous chloride and the molybdenum complex is extracted with butyl acetate. Spectrophotometric measurement is made at approximately 475 nm.

81. Concentration Range

81.1 The recommended concentration range is from 0.0003 mg to 0.003 mg of molybdenum per millilitre of solution using a 1-cm cell.

NOTE 25—This test method has been written for cells having a 1-cm light path. Cells having other dimensions may be used, provided suitable adjustments can be made in the amounts of sample and reagents used.

82. Stability of Color

82.1 The color is stable for at least 2 h; however, spectrophotometric readings should be taken promptly because of the volatile nature of the solvent.

83. Interferences

83.1 The elements ordinarily present do not interfere if their contents are under the maximum limits shown in [1.1](#).

84. Reagents

84.1 *Butyl Acetate*:

NOTE 26—Operations with this chemical should be conducted away from heat and open flame and are best done in a well-ventilated hood. Avoid prolonged breathing of vapor.

84.2 *Dissolving Solution*—While stirring, add 300 mL of H_3PO_4 and 300 mL of HNO_3 to 1400 mL of HClO_4 .

84.3 *Iron*¹¹—purity 99.8 % minimum, molybdenum 0.001 % maximum.

84.4 *Iron Solution A* (1 mL = 70 mg Fe)—Dissolve 25 g of ferric sulfate ($\text{Fe}_2(\text{SO}_4)_3 \cdot \text{H}_2\text{O}$) in 75 mL of hot water. Cool and add 10 mL of H_2SO_4 . Cool and dilute to 100 mL.

84.5 *Iron Solution B* (1 mL = 0.84 mg Fe)—Add 12 mL of Iron Solution A to 175 mL of H_2SO_4 (1 + 1) and dilute to 1 L.

84.6 *Molybdenum, Standard Solution A* (1 mL = 0.2 mg Mo)—Transfer 0.2000 g of molybdenum metal (purity: 99.8 % min) to a 150-mL beaker and dissolve in 10 mL of HCl and HNO_3 added dropwise. Cool, transfer to a 1-L volumetric flask, dilute to volume, and mix.

84.7 *Molybdenum, Standard Solution B* (1 mL = 0.1 mg Mo)—Using a pipet, transfer 50 mL of molybdenum Solution A to a 100-mL volumetric flask, dilute to volume, and mix.

84.8 *Molybdenum, Standard Solution C* (1 mL = 0.01 mg Mo)—Using a pipet, transfer 10 mL of molybdenum Solution A to a 200-mL volumetric flask, dilute to volume, and mix.

84.9 *Sodium Thiocyanate Solution* (100 g/L)—Dissolve 100 g of sodium thiocyanate (NaSCN) in about 500 mL of water, filter, and dilute to 1 L. Store in a dark bottle.

84.10 *Stannous Chloride Solution* (350 g/L)—Transfer 350 g of stannous chloride dihydrate ($\text{SnCl}_2 \cdot 2\text{H}_2\text{O}$) and 200 g of tartaric acid to a 1-L beaker, add 400 mL of HCl (1 + 1), and heat at 60 °C to 70 °C until dissolution is complete. Cool, and dilute to 1 L. Add several pieces of tin, and store in an air-tight bottle.

NOTE 27—This solution is used for color development in [84.3](#), [85.3](#), [86.3](#), and [87.3](#). When an absorption cell is used sequentially for a number of spectrophotometric measurements, a white film of an insoluble tin compound may adhere to the inside of the cell and must be removed before further measurements are made.

85. Preparation of Calibration Curve for Contents from 0.01 % to 0.05 %

85.1 *Calibration Solutions*:

85.1.1 Transfer 0.3 g of iron to each of four 250-mL Erlenmeyer flasks. Using pipets, transfer (2, 5, 10, and 15) mL of Molybdenum Solution C (1 mL = 0.01 mg Mo) to the flasks. Add 30 mL of dissolving solution and heat until dissolution is complete.

85.1.2 Increase the temperature and evaporate to HClO_4 fumes. Cool, add 50 mL of water and 70 mL of H_2SO_4 (1 + 1). Heat to boiling and cool in a water bath.

85.1.3 Transfer to a 200-mL volumetric flask, dilute to volume and mix. Proceed as directed in [85.3](#).

85.2 *Reagent Blank Solution*—Transfer 0.3 g of iron to a 250-mL Erlenmeyer flask. Add 30 mL of dissolving solution and heat until dissolution is complete. Proceed as directed in [85.1.2](#) and [85.1.3](#).

85.3 *Color Development*—Using a pipet, transfer 100 mL to a 250-mL separatory funnel. Add in order, mixing for 15 s after each addition, 15 mL of NaSCN solution, 15 mL of SnCl_2 solution and 25 mL of butyl acetate measured with a pipet. Stopper and shake vigorously for 2 min. Allow the phases to separate, remove the stopper, drain off and discard the aqueous phase. Add to the funnel 50 mL of H_2SO_4 (1 + 6), 5 mL of NaSCN solution and 5 mL of SnCl_2 solution. Replace the stopper and shake vigorously for 2 min. Allow the phases to separate, remove the stopper, drain off and discard the aqueous

¹¹ Johnson-Matthey JMC 847 sponge iron has been found suitable for this purpose.

phase. Drain enough of the butyl acetate layer through a funnel, containing a dry filter paper, to fill an absorption cell.

85.4 *Reference Solution*—Butyl acetate.

85.5 *Spectrophotometry*:

85.5.1 *Multiple Cell Spectrophotometer*—Measure the reagent blank (which includes the cell correction) using absorption cells with a 1-cm light path and a light band centered at approximately 475 nm. Using the test cell, take the spectrophotometric readings of the calibration solutions.

85.5.2 *Single Cell Spectrophotometer*—Transfer a suitable portion of the reference solution to an absorption cell with a 1-cm light path and adjust the spectrophotometer to the initial setting, using a light band centered at approximately 475 nm. While maintaining this adjustment, take the spectrophotometric readings of the calibration solutions and the reagent blank.

85.6 *Calibration Curve*—Follow the instrument manufacturer's instructions for generating the calibration curve.

86. Preparation of Calibration Curve for Contents from 0.05 % to 0.55 %

86.1 *Calibration Solutions*:

86.1.1 Transfer 0.3 g of iron to each of four 250-mL Erlenmeyer flasks. Using pipets, transfer (2, 5, 10, and 15) mL of Molybdenum Solution B (1 mL = 0.1 mg Mo) to the flasks. Add 30 mL of dissolving solution and heat until dissolution is complete.

86.1.2 Increase the temperature and evaporate to HClO₄ fumes. Cool and add 50 mL of water and 70 mL of H₂SO₄ (1 + 1). Heat to boiling and cool in a water bath.

86.1.3 Transfer to a 500-mL volumetric flask, dilute to volume, and mix. Proceed as directed in 86.3.

86.2 *Reagent Blank Solution*—Transfer 0.3 g of iron to a 250-mL Erlenmeyer flask. Add 30 mL of dissolving solution and heat until dissolution is complete. Proceed as directed in 86.1.2 and 86.1.3.

86.3 *Color Development*—Using a pipet, transfer 50 mL to a 250-mL separatory funnel. Add in order, mixing for 15 s after each addition, 15 mL of NaSCN solution, 15 mL of SnCl₂ solution and 50 mL of butyl acetate measured with a pipet. Stopper and shake vigorously for 2 min. Allow the phases to separate, remove the stopper, drain off, and discard the aqueous phase. Add to the funnel 50 mL of H₂SO₄ (1 + 6), 5 mL of NaSCN solution, and 5 mL of SnCl₂ solution. Replace the stopper and shake vigorously for 2 min. Allow the phases to separate, remove the stopper, drain off and discard the aqueous phase. Drain enough of the butyl acetate layer through a funnel containing a dry filter paper to fill an absorption cell. (See Note 28.)

NOTE 28—This funnel should be cleaned thoroughly after each filtration to avoid development of a pink color that would contaminate the filtrate.

86.4 *Reference Solution*—Butyl acetate.

86.5 *Spectrophotometry*:

86.5.1 *Multiple Cell Spectrophotometer*—Measure the reagent blank (which includes the cell correction) using absorption cells with a 1-cm light path and a light band centered at

approximately 475 nm. Using the test cell, take the spectrophotometric readings of the calibration solutions.

86.5.2 *Single Cell Spectrophotometer*—Transfer a suitable portion of the reference solution to an absorption cell with a 1-cm light path and adjust the spectrophotometer to the initial setting, using a light band centered at approximately 475 nm. While maintaining this adjustment, take the spectrophotometric readings of the calibration solutions and the reagent blank.

86.6 *Calibration Curve*—Follow the instrument manufacturer's instructions for generating the calibration curve.

87. Preparation of Calibration Curve for Contents from 0.40 % to 1.50 %

87.1 *Calibration Solutions*:

87.1.1 Transfer 0.3 g of iron to each of five 250-mL Erlenmeyer flasks. Using pipets, transfer (5, 10, 15, 20, and 25) mL of Molybdenum Solution A (1 mL = 0.2 mg Mo) to the flask. Add 30 mL of dissolving solution and heat until dissolution is complete.

87.1.2 Increase the temperature and evaporate to HClO₄ fumes. Cool, add 50 mL of water and 70 mL of H₂SO₄ (1 + 1). Heat to boiling and cool in a water bath.

87.1.3 Transfer to a 500-mL volumetric flask, dilute to volume, and mix. Proceed as directed in 87.3.

87.2 *Reagent Blank Solution*—Transfer 0.3 g of iron to a 250-mL Erlenmeyer flask. Add 300 mL of dissolving solution and heat until dissolution is complete. Proceed as directed in 87.1.2 and 87.1.3.

87.3 *Color Development*—Using a pipet, transfer 25 mL of Iron Solution B and 25 mL of the calibration solution to a 250-mL separatory funnel. Add in order, mixing for 15 s after each addition, 15 mL of NaSCN solution, 15 mL of SnCl₂ solution and 100 mL of butyl acetate measured with a pipet. Stopper and shake vigorously for 2 min. Allow the phases to separate, remove the stopper, drain off, and discard the aqueous phase. Add to the funnel 50 mL of H₂SO₄ (1 + 6), 5 mL of NaSCN solution and 5 mL of SnCl₂ solution. Replace the stopper and shake vigorously for 2 min. Allow the phases to separate, remove the stopper, drain off and discard the aqueous phase. Drain enough of the butyl acetate layer through a funnel containing a dry filter paper to fill an absorption cell. (See Note 28.)

87.4 *Reference Solution*—Butyl acetate.

87.5 *Spectrophotometry*:

87.5.1 *Multiple Cell Spectrophotometer*—Measure the reagent blank (which includes the cell correction) using absorption cells with a 1-cm light path and a light band centered at approximately 475 nm. Using the test cell, take the spectrophotometric readings of the calibration solutions.

87.5.2 *Single-Cell Spectrophotometer*—Transfer a suitable portion of the reference solution to an absorption cell with a 1-cm light path and adjust the spectrophotometer to the initial setting, using a light band centered at approximately 475 nm. While maintaining this adjustment, take the spectrophotometric readings of the calibration solutions and the reagent blank.

87.6 *Calibration Curve*—Follow the instrument manufacturer’s instructions for generating the calibration curve.

88. Procedure

88.1 *Test Solution:*

88.1.1 Transfer 0.3-g sample, weighed to the nearest 1 mg to a 250-mL Erlenmeyer flask. If the alloy contains tungsten, add 30 mL of dissolving acid. Add HCl, or HNO₃, or mixtures and dilutions of these acids, or bromine and HCl in a ratio of 1:3 (plus a few drops of HF), and heat until dissolution is complete.

88.1.2 Increase the temperature and heat to HClO₄ fumes. Continue fuming until chromium, if present, is oxidized and the white HClO₄ fumes are present only in the neck of the flask. Add, with care, 1.0 mL to 1.5 mL of HCl, allowing it to drain down the side of the flask. If there is evidence of the volatilization of chromyl chloride, make repeated additions of HCl, followed by fuming after each addition, until most of the chromium has been volatilized. Continue fuming the solution until the volume has been reduced to about 15 mL. Cool, add 50 mL of water and 70 mL of H₂SO₄ (1 + 1), heat to boiling and cool in a water bath. If the solution is not clear, filter the solution through an 11-cm fine filter paper, collecting the filtrate in a volumetric flask that provides for dilution in accordance with the guide given in 88.1.3. Wash the paper with five 5-mL portions of H₂SO₄ (1 + 99) collecting these in the same volumetric flask. If the solution is clear, proceed to 88.1.3.

88.1.3 Transfer to a volumetric flask that provides for dilution in accordance with the following aliquot guide, dilute to volume and mix.

88.1.3.1

Molybdenum, %	Dilution, mL	Aliquot Volume, mL	Iron Solution B, mL	Butyl Acetate, mL	Weight of Sample in Final Butyl Acetate Solution, g
0.01 to 0.05	200	100	None	25	0.15
0.05 to 0.55	500	50	None	50	0.03
0.40 to 1.50	500	25	25	100	0.015

88.1.3.2 Proceed as directed in 88.3.

88.2 *Reagent Blank Solution*—Transfer 0.3 g of iron to a 250-mL Erlenmeyer flask. Add 30 mL of dissolving solution and heat until dissolution is complete. Proceed as directed in 88.1.2, 88.1.3, and 88.3, using the same dilution and aliquots used for the test solution.

88.3 *Color Development*—Using a pipet, transfer the appropriate aliquot to a 250-mL separatory funnel containing the appropriate amount of iron solution for the specified aliquot. Add in order, mixing for 15 s after each addition, 15 mL of NaSCN solution, 15 mL of SnCl₂ solution, and, measured with a pipet, the amount of butyl acetate specified in the aliquot guide. Stopper the separatory funnel and shake vigorously for 2 min. Allow the phases to separate, remove the stopper, drain off and discard the aqueous phase. Add to the funnel 50 mL of H₂SO₄ (1 + 6), 5 mL of NaSCN solution, and 5 mL of SnCl₂ solution. Replace the stopper and shake vigorously 2 min. Allow the phases to separate, drain off and discard the aqueous

phase. Drain enough of the solvent layer through a funnel containing a dry filter paper to fill an absorption cell. (See Note 28.)

88.4 *Reference Solution*—Butyl acetate.

88.5 *Spectrophotometry*—Take the spectrophotometric reading of the test solution and of the reagent blank solution as directed in 86.5.

89. Calculation

89.1 Convert the net spectrophotometric reading of the test solution to milligrams of molybdenum in the final solution by means of the appropriate calibration curve. Calculate the percent of molybdenum as follows:

$$\text{Molybdenum, \%} = \frac{A}{B \times 10} \quad (12)$$

where:

A = molybdenum, mg, found in (25, 50, or 100) mL, as appropriate of butyl acetate, and the aliquot volume used, and

B = sample, g, represented in (25, 50, or 100) mL, as appropriate, of butyl acetate and the aliquot used (see aliquot guide 88.1.3).

90. Precision and Bias

90.1 *Precision*¹²—No data are presently available to determine the precision of this test method. However, the difference between this test method and molybdenum Test Methods E350, E351, E352, and E353 are minor and will not affect the precision of the results (see Table 9). This fact suggests that the precision for these test methods is the same.

90.2 *Bias*—No data are presently available to determine the accuracy of this method.

CHROMIUM BY THE ATOMIC ABSORPTION METHOD

91. Scope

91.1 This test method covers the determination of chromium from 0.018 % to 1.00 %.

92. Summary of Test Method

92.1 The sample is dissolved in mineral acids and the residue fused, dissolved and combined with the soluble portion. The sample solution is aspirated into a nitrous oxide-acetylene flame of an atomic absorption spectrometer. Spectral

¹² Supporting data have been filed at ASTM International Headquarters and may be obtained by requesting Research Report RR:E03-1023.

TABLE 9 Statistical Information—Molybdenum

Test Specimen	Molybdenum Found, %	Repeatability R ₁ , Practice E173	Reproducibility R ₂ , Practice E173
1. No. 1, Test Methods E350	0.012	0.002	0.006
2. No. 3, Test Methods E353	0.432	0.010	0.017

energy at approximately 357.9 nm from a chromium hollow-cathode lamp is passed through the flame and the absorbance is measured. The spectrometer is calibrated with solutions of known chromium concentrations.

93. Concentration Range

93.1 The recommended concentration range is from 0.001 mg to 0.015 mg of chromium per millilitre of solution.

94. Interferences

94.1 Because iron acts as a depressant, the calibration solutions must contain approximately the same concentration of iron as the test solutions.

95. Apparatus

95.1 *Atomic Absorption Spectrometer*, capable of resolving the 357.9-nm line, equipped with a chromium hollow-cathode lamp and a laminar flow nitrous oxide burner. The performance of the instrument must be such that it meets the limits defined in 97.4. If your instrument does not meet this criterion, you cannot expect to obtain the precision and accuracy stated in this test method.

96. Reagents

96.1 *Chromium Standard Solution* (1 mL = 0.1 mg Cr)—Transfer 2.8290 g of potassium dichromate ($K_2Cr_2O_7$) (NIST 136 or equivalent) to an 800-mL borosilicate beaker, add 500 mL of water and mix. When dissolution is complete, add 5 mL of H_2SO_4 and, while stirring, add 10 mL of H_2O_2 (30 %). Heat at near boiling for 5 min to remove excess H_2O_2 . Cool, transfer the solution to a 1-L volumetric flask, dilute to volume and mix. Using a pipet, transfer 20 mL to a 200-mL volumetric flask, dilute to volume and mix.

96.2 *Iron*,¹³ *Low Chromium*—Cr < 0.0001 %.

96.3 *Potassium Carbonate Solution* (50 g/L)—Dissolve 50 g of potassium carbonate (K_2CO_3) in water and dilute to 1 L. Store the solution in a polyethylene bottle.

97. Preparation of Calibration Curves

97.1 *Calibration Solutions for Contents 0.005 % to 0.10 %*—To each of seven 250-mL borosilicate beakers, transfer 1.0 g of low-chromium iron weighed to the nearest 1 mg. Add to each beaker 20 mL of HCl and 10 mL of HNO_3 and heat gently until dissolution is complete. Evaporate to dryness on a hot plate and cool. Add 10 mL of HCl and warm to dissolve salts. Dilute to about 50 mL and transfer to 100-mL volumetric flasks. Add 10 mL of K_2CO_3 solution to each of seven flasks. Using pipets, transfer (1, 3, 5, 7, 10, and 15) mL of chromium standard solution to each flask respectively. Designate the seventh flask as zero chromium concentration. Dilute to volume and mix.

97.2 *Calibration Solution for Contents 0.10 % to 1.00 %*—Transfer 2 g of low-chromium iron weighed to the nearest 1 mg to a 250-mL borosilicate beaker. Add 20 mL of HCl and

10 mL of HNO_3 . Warm as necessary to dissolve the sample. Evaporate just to dryness on a hot plate and cool. Add 20 mL of HCl and warm to dissolve salts. Dilute to about 100 mL and add 20 mL of K_2CO_3 solution. Transfer to a 200-mL volumetric flask, dilute to volume and mix. Transfer 10-mL aliquots to each of seven 100-mL volumetric flasks and add 9 mL of HCl to each flask. Using pipets, transfer (1, 3, 5, 7, 10, and 15) mL of chromium standard solution to each flask respectively. Designate the seventh flask as zero chromium concentration. Dilute to volume and mix.

97.3 Spectrometry:

97.3.1 With the chromium hollow-cathode lamp in position, energized and stabilized, adjust the wavelength to maximize the energy response of the 357.9-nm line. The wavelength setting in the vicinity of 428.9 nm may be used provided that the instrument meets the performance requirements.

97.3.2 Light the burner, allow it to thermally equilibrate and adjust the instrument to zero while aspirating water. Aspirate the chromium solution with the highest concentration from the series prepared as directed in 97.1, and adjust the burner, nitrous oxide and fuel pressures and flow rates to obtain maximum response. Whenever one or more of these parameters are changed, recalibration is required.

97.3.3 Aspirate the chromium solutions used in 97.3.2 to assure that the absorbance reading is repeatable. Record six readings, and calculate the standard deviation, s , of the readings as follows:

$$s = (A - B) \times 0.40 \quad (13)$$

where:

A = highest of six values found, and
 B = lowest of the six values found.¹⁴

97.3.4 Using water as a reference solution, and beginning with the solution to which no addition of chromium was made in 97.1 and 97.2, aspirate each calibration solution in turn and record its absorbance. If the value for the solution with the highest concentration differs from the average of six values calculated in 97.3.3 by more than twice the standard deviation, or by more than 0.01 multiplied by the average of the six values, whichever is greater, repeat the measurement. If a problem is indicated, determine the cause, correct it and repeat 97.3.1 – 97.3.4.

97.3.5 Proceed immediately as directed in Section 97.4.

97.4 *Calibration for Contents from 0.005 % to 0.10 %*—Follow the instrument manufacturer's instructions for generating the calibration curve. Calculate the deviation from linearity of the curve as follows:

$$\text{Deviation from linearity} = (C - D)/E \quad (14)$$

where:

C = absorbance value for 0.015 mg Cr/mL,
 D = absorbance value for 0.010 mg Cr/mL, and
 E = absorbance value for 0.005 mg Cr/mL.

¹³ Johnson-Matthey sponge iron or Spex iron has been found suitable for this purpose.

¹⁴ The value 0.40, which is used to estimate the standard deviation from the range of six values, was published by: Dixon, W. J., and Massey, F. J., *Introduction to Statistical Analysis*, McGraw-Hill, Table 8b, (1), 1957, p. 404.

If the calculated value is less than 0.60, make the proper adjustments of instrument or hollow cathode lamp, and repeat the calibration. The absorbance value for *C* must be 0.200 or higher.

97.5 *Calibration for Contents from 0.10 % to 1.00 %*—Proceed as directed in 97.4.

98. Procedure

98.1 Test Solution:

98.1.1 Select and weigh a sample in accordance with the following.

98.1.1.1

Chromium, %	Sample Weight, g	Tolerance in Sample Weight, mg	Dilution After Dis-solution, mL	Aliquot Required, mL	HCl to be added to Ali-quot, mL	Final Dilution, mL
0.005–0.10	1	0.10	100	0	0	100
0.10–1.00	1	0.10	100	10	9	100

98.1.1.2 Transfer it to a 250-mL borosilicate beaker.

98.1.2 Add 20 mL HCl, 10 mL HNO₃ and 5 drops of HF. Heat to dissolve. Remove from the hot plate and dilute to approximately 50 mL. Add a small amount of filter pulp and filter the solution through 11-cm fine filter paper into a 250-mL borosilicate beaker. Wash the paper five times with HCl (1 + 99) and reserve the filtrate.

98.1.3 Transfer the paper and contents to a platinum crucible. Dry on a hot plate and transfer to a muffle furnace that is less than 400 °C. Gradually heat to 600 °C and hold at this temperature for 1 h. Cool, add 0.5 g of K₂CO₃ and carefully fuse over a free flame until a clear melt is obtained (see Note 29). Cool and add 15 mL of water. Add HCl dropwise until reaction ceases. Add five drops of HCl in excess and warm on a hot plate, if necessary, to obtain a clear solution.

NOTE 29—Fusion of the residue is made in order to include in the sample solution any chromium that might exist in the sample in an acid insoluble form.

98.1.4 Transfer this solution to the filtrate from 98.1.2 and evaporate just to dryness. Add 10 mL HCl and warm to dissolve salts. Transfer quantitatively to a 100-mL volumetric flask, dilute to volume and mix. For samples with expected chromium contents less than 0.10 %, proceed as directed in 98.3. For samples with expected chromium contents greater than 0.10 %, transfer by pipet 10 mL to a 100-mL volumetric flask, add 9 mL of HCl, dilute to volume and mix.

98.2 Prepare for each concentration range a reagent blank by treating the same amount of all reagents as directed in 98.1.1 – 98.1.4, including the low-chromium iron. Use reagents from the same lots for blank and test solutions.

98.3 *Spectrometry*—Using water as a reference solution, aspirate and record the absorbance of the calibration, test and reagent blank solutions. After each group of four or fewer test solutions and reagent blank solutions has been aspirated, apply the test using the standard solution as directed in 97.3.4, depending on the concentration range. If the value differs from the average of the six values by more than twice the standard deviation, *s*, found in 97.3.3, or more than 0.01 multiplied by the average of six values used to calculate *s*, whichever is

greater, determine the cause and repeat the calibration and aspiration of test solutions.

99. Calculation

99.1 Convert the absorbance of the test solution and the reagent blank to milligrams of chromium per millilitre of the final test solution by means of the appropriate calibration curve. Calculate the percent chromium as follows:

$$\text{Chromium, \%} = \frac{(A - B) \times C}{W \times 10} \quad (15)$$

where:

- A* = chromium per mL of final test solution, mg,
- B* = chromium per mL of final reagent blank solution, mg,
- C* = final volume of test solution and
- W* = weight of sample in final volume of test solution, g.

100. Precision and Bias¹⁵

100.1 *Precision*—Nine laboratories cooperated in testing this test method and obtained the precision data summarized in Table 10.

100.2 *Bias*—No data are presently available to determine the accuracy of this method.

CHROMIUM BY THE PEROXYDISULFATE OXIDATION—TITRATION METHOD

101. Scope

101.1 This test method covers the determination of chromium from 0.10 % to 33.00 %.

102. Summary of Test Method

102.1 Chromium in an acid solution of the sample is oxidized to the hexavalent state with ammonium peroxydisulfate in the presence of silver nitrate catalyst. The sample is then titrated with excess ferrous ammonium sulfate to reduce chromium and the excess back-titrated with either potassium permanganate or potassium dichromate depending upon the presence or absence of vanadium.

NOTE 30—In the dichromate titration, the vanadium is not oxidized along with the excess ferrous ions and, therefore, the volume of dichromate added reflects the total of vanadium and chromium and the calculated value for percent Cr is high. In the permanganate titration, the V^{IV} is oxidized to V^V, thereby compensating for the reduction of vanadium by ferrous sulfate in a previous step.

¹⁵ Supporting data have been filed at ASTM International Headquarters and may be obtained by requesting Research Report RR:E03-1030.

TABLE 10 Statistical Information—Chromium

Test Specimen	Chromium Found, %	Repeatability (<i>R</i> ₁ , Practice E173)	Reproducibility (<i>R</i> ₂ , Practice E173)
1. 40 Ni 0.2 Si 0.5 Mn 0.02 C Steel	0.072	0.007	0.009
2. No. 1, Test Methods E352	0.149	0.028	0.028
3. 18 Ni 9 Co 5 Mo 0.5 Ti Steel	0.961	0.036	0.093

103. Interferences

103.1 The elements ordinarily present do not interfere if their contents are less than the maximum limits shown in 1.1.

103.2 Each of the following elements, when present above the indicated limit, imparts color to the solution so that diphenylamine sulfonate indicator cannot be used when $K_2Cr_2O_7$ is chosen as the back-titrant. The limits are: nickel 1.300 g, copper 0.260 g, tungsten 0.005 g. The effects of the elements are additive. If the numerical value of the following expression does not exceed 1.300, the indicator may be used:

$$(2.6A + 0.05B + 0.01C) D \quad (16)$$

where:

- A = tungsten in the sample, %,
- B = copper in the sample, %,
- C = nickel in the sample, %, and
- D = sample weight, g.

When the value exceeds 1.300, the end point must be determined potentiometrically if $K_2Cr_2O_7$ is the back-titrant.

104. Apparatus

104.1 *Apparatus for Potentiometric Titrations*—See 28.2.

105. Reagents

105.1 *Ammonium Peroxydisulfate Solution*—Dissolve 15 g of ammonium peroxydisulfate $[(NH_4)_2S_2O_8]$ in water and dilute to 100 mL. Do not use solutions that have stood for more than 24 h.

105.2 *Ferrous Ammonium Sulfate, Standard Solutions* (0.05 N and 0.10 N)—Dissolve 20 g and 40 g of ferrous ammonium sulfate $(Fe(NH_4)_2(SO_4)_2 \cdot 6H_2O)$ in 500 mL of cold H_2SO_4 (5 + 95) and dilute to 1 L with H_2SO_4 (5 + 95). Standardize the solution as directed in 106.1, 106.2, or 106.3 depending upon the titration procedure to be employed. Use only if the solution has been standardized or restandardized within 24 h.

105.3 *Potassium Dichromate, Standard Solution* Dissolve 2.4518 g and 4.9036 g of NIST 136c standard potassium dichromate ($K_2Cr_2O_7$) or equivalent primary standard grade in water, transfer to a 1-L volumetric flask, dilute to volume, and mix.

105.4 *Potassium Permanganate Solution* (25 g/L)—Dissolve 25 g of reagent grade $KMnO_4$ in 200 mL of water, dilute to 1 L, and mix.

105.5 *Potassium Permanganate, Standard Solution* (0.05 N and 0.10 N):

105.5.1 *Preparation*—Dissolve 1.6 g and 3.2 g of potassium permanganate ($KMnO_4$) in 1 L of water. Let stand in the dark for 2 weeks. Filter, without washing, through a Gooch crucible or a fine porosity fritted-glass crucible. Avoid contact with rubber or other organic material. Store in a dark-colored glass-stoppered bottle.

105.5.2 *Standardization*—Dry a portion of the NIST 40h or equivalent primary standard grade sample of sodium oxalate at 105 °C. Transfer 0.1500 g of the sodium oxalate to a 600-mL beaker. Add 250 mL of H_2SO_4 (5 + 95), previously boiled for

10 min to 15 min and then cooled to $27\text{ °C} \pm 3\text{ °C}$, and stir until the oxalate has dissolved. Add 39 mL to 40 mL of the $KMnO_4$ solution, at a rate of 25 mL/min to 35 mL/min, while stirring slowly. Let stand until the pink color disappears (about 45 s). Heat to 55 °C to 60 °C and complete the titration by adding $KMnO_4$ solution until a faint pink color persists for 30 s. Add the last 0.5 mL to 1 mL dropwise, allowing each drop to become decolorized before adding the next drop. To determine the blank: Titrate 250 mL of H_2SO_4 (5 + 95), treated as above, with $KMnO_4$ solution to a faint pink color. The blank correction is usually equivalent to 0.03 mL to 0.05 mL.

105.6 *Silver Nitrate Solution* (8 g/L)—Dissolve 8 g of silver nitrate ($AgNO_3$) in water and dilute to 1 L.

105.7 *Sodium Diphenylamine Sulfonate Indicator Solution* (2.0 g/L).

105.7.1 *Preparation from Barium Diphenylamine Sulfonate*—Dissolve 0.32 g of barium diphenylamine sulfonate in 100 mL of hot water. Add 0.5 g of sodium sulfate (Na_2SO_4), stir, and filter through a fine paper to remove the $BaSO_4$. Store in a dark-colored bottle.

105.7.2 *Preparation from Sodium Diphenylamine Sulfonate*—Dissolve 0.20 g of sodium diphenylamine sulfonate in 100 mL of water. Store in a dark-colored bottle.

105.8 *1,10 Phenanthroline Ferrous Complex Indicator Solution* (0.025 M)—Dissolve 6.95 g of ferrous sulfate ($FeSO_4 \cdot 7H_2O$) in 500 mL of water and dilute to 1 L. Dissolve 1.485 g of 1,10-phenanthroline monohydrate in 100 mL of the ferrous sulfate solution ($FeSO_4 \cdot 7H_2O$).

106. Standardization of Ferrous Ammonium Sulfate Solution

106.1 *Against Potassium Permanganate Solution:*

106.1.1 Transfer 180 mL of water, 12 mL of H_2SO_4 (1 + 1) and 5 mL of H_3PO_4 into a 500-mL Erlenmeyer flask. Add 20 mL of 0.05 N or 0.10 N $Fe(NH_4)_2(SO_4)_2$ with either 0.05 N or 0.10 N $KMnO_4$ solution (105.5) from a 25-mL burette and record the volume to the nearest 0.01 mL. Add one drop to two drops of 1,10 phenanthroline indicator solution. Using a 25-mL burette, titrate the ferrous ions with 0.05 N $KMnO_4$ standard solution (105.5) while swirling the flask. As the end point is approached, add $KMnO_4$ dropwise. Continue until the pink color changes to clear green and persists for at least 60 s.

106.1.2 Calculate the normality of the $Fe(NH_4)_2(SO_4)_2$ solution as follows:

$$\text{Normality} = AB/C \quad (17)$$

where:

- A = normality of $KMnO_4$ solution (105.5),
- B = $KMnO_4$ solution, mL, and
- C = $Fe(NH_4)_2(SO_4)_2$ solution, mL.

106.2 *Against Potassium Dichromate Solution Using Diphenylamine Sulfonate End Point:*

106.2.1 Transfer 180 mL of water, 12 mL of H_2SO_4 (1 + 1) and 5 mL of H_3PO_4 into a 500-mL Erlenmeyer flask. Add 20 mL of 0.05 N or 0.10 N $Fe(NH_4)_2(SO_4)_2$ (105.2) from a 25-mL buret and record the volume to the nearest 0.01 mL. Add two drops of diphenylamine sulfonate indicator solution.

Using a 25-mL buret, titrate the ferrous ions with either 0.05 *N* or 0.10 *N* K₂Cr₂O₇ solution, while swirling the flask. As the end point is approached, add the K₂Cr₂O₇ titrant dropwise. Continue until a blue color appears and persists for at least 30 s. Record the buret reading to the nearest 0.01 mL. Refill the burets, add the same volume of Fe(NH₄)₂(SO₄)₂ solution, and again titrate with either 0.05 *N* or 0.10 *N* K₂Cr₂O₇ solution to the blue end point. Subtract this volume of K₂Cr₂O₇ solution from the volume recorded for the first titration and record the difference as the indicator blank.

106.2.2 Calculate the normality of the Fe(NH₄)₂(SO₄)₂ solution as follows:

$$\text{Normality} = (0.05 \text{ or } 0.10 (A - B))/C \quad (18)$$

where:

- A = 0.05 *N* or 0.10 *N* K₂Cr₂O₇ solution used in the first titration, mL,
- B = mL equivalent to the indicator blank and
- C = Fe(NH₄)₂(SO₄)₂ solution used in the first titration, mL.

106.3 Against Potassium Dichromate Using Potentiometric End Point:

106.3.1 Using a 25-mL buret, transfer 20 mL of 0.05 *N* or 0.10 *N* K₂Cr₂O₇ solution into a 600-mL beaker. Reserve the remaining 0.05 *N* or 0.10 *N* K₂Cr₂O₇ solution in the buret for the back-titration. Add 150 mL of water, 10 mL of H₂SO₄ (1 + 1) and 5 mL of H₃PO₄. Insert the saturated calomel reference electrode and the platinum indicator electrode into the beaker and connect them to the potentiometer apparatus. While stirring the solution, add Fe(NH₄)₂(SO₄)₂ until the dichromate ion yellow color disappears and then a slight excess. Record the volume of the Fe(NH₄)₂(SO₄)₂ solution to the nearest 0.01 mL. Back-titrate with the remaining 0.05 *N* or 0.10 *N* K₂Cr₂O₇ solution by adding the solution in 0.1-mL increments as the end point is approached. Record the voltage when equilibrium is reached after each 0.1-mL increment. Inspect the data for the maximum voltage change per 0.1-mL increment. Determine the voltage change for the 0.1-mL increments before and after this maximum change. Determine the two differences between the three voltage readings corresponding to the volume (0.1-mL) increment before the maximum, the maximum and after the maximum. This is a very close approximation of the second derivative of the volume versus change in voltage curve corresponding to the maximum inflection if this curve was plotted. Sum the two voltage differences. Determine the ratio of the first of these two differences to the sum and multiply 0.1 mL by this ratio to obtain the volume to be added to the smaller volume between the two incremental additions that the maximum change in voltage occurred. See the following example:

Volume of 0.05 <i>N</i> K ₂ Cr ₂ O ₇ Back Titrant, mL	Voltage, mV	Δ Voltage, mV	Difference Before and After, max
20.80	555		
20.90	570	50	50
21.00	620	100	20
21.10	720	80	
21.20	800		
21.30	835		
21.40	854		

Maximum voltage change occurred between 21.00 mL and 21.10 mL of K₂Cr₂O₇ solution. The changes in voltage were 50 mV before the maximum, 100 mV at the maximum, and 80 mV after the maximum. The two differences between the maximum corresponding to before and after the maximum were 50 mV and 20 mV, respectively. Their sum equals 70 and the ratio of the first to the sum equals 50/70. Thus 50/70 multiplied by 0.1 mL must be *added* to the smaller volume between the two increments where the maximum change in voltage occurred. The end point is 21.07 mL.

106.3.2 Calculate the normality of the Fe(NH₄)₂(SO₄)₂ solution as follows:

$$\text{Normality} = 0.05 \text{ or } 0.10 A/B \quad (19)$$

where:

- A = 0.05 or 0.10 *N* K₂Cr₂O₇ solution, mL and
- B = Fe(NH₄)₂(SO₄)₂ solution, mL.

107. Procedure

107.1 Select and weigh a sample in accordance with the following.

107.1.1

Chromium, %	Sample Weight, g	Tolerance in Sample Weight, mg	Normality of Titrants
0.10 to 0.50	3.50	2.0	0.05
0.40 to 1.00	2.00	1.0	0.05
0.80 to 1.60	1.25	0.3	0.05
1.50 to 3.50	0.50	0.1	20.05
3.30 to 8.00	0.25	0.1	0.05
8.00 to 14.00 ^A	0.50	0.1	0.10
13.00 to 20.00 ^A	0.40	0.1	0.10
18.00 to 30.00 ^A	0.20	0.1	0.10
28.00 to 33.00 ^A	0.15	0.1	0.10

^A Use 50-mL burets for this range instead of the 25-mL burets specified in the procedure.

Transfer it to a 600-mL beaker.

107.2 Add 80 mL of H₂SO₄ (1 + 5) and 5 mL of H₃PO₄. Cover the beaker with a ribbed cover glass and heat at 85 °C to 100 °C until the sample is decomposed. Add sufficient HNO₃ in small increments to oxidize iron. Boil 2 min to expel oxides of nitrogen. Proceed as directed in 107.4.

107.3 If the alloy does not dissolve in the acids specified in 107.2, add amounts of HCl or HNO₃, or mixtures and dilutions of these acids, or bromine and HCl in a ratio of 1:3 plus a few drops of HF, which are sufficient to dissolve the sample. When dissolution is complete, add 80 mL of H₂SO₄ (1 + 5), 5 mL of H₃PO₄ and evaporate to light fumes. Rinse the cover and walls of the beaker. Again evaporate to fumes and fume for 1 min. Cool, add 100 mL of water and heat at 85 °C to 100 °C until salts are dissolved.

107.4 Dilute the solution to 150 mL, add paper pulp and filter through an 11-cm fine paper into a 500-mL Erlenmeyer flask or a 600-mL beaker if the potentiometric titration procedure is to be used. Wash the residue ten times to twelve times with warm water and reserve the filtrate.

107.5 Transfer the paper and residue to a platinum crucible, char the paper and ignite at 850 °C to 900 °C for 15 min. Cool, add sufficient H₂SO₄ (1 + 1) to moisten the residue and then

3 mL to 5 mL of HF. Evaporate to dryness and heat at a gradually increasing rate until H₂SO₄ is removed. Fuse the residue with a minimum amount of either fused sodium hydrogen sulfate (sodium pyrosulfate—Na₂S₂O₇) or potassium pyrosulfate (K₂S₂O₇). Cool the crucible, place in a 250-mL beaker and dissolve the melt in 20 mL of H₂SO₄ (1 + 10). Remove the crucible, rinse with water, transfer the solution to the reserved filtrate (107.4) and dilute to 200 mL.

107.6 Add 5 mL of AgNO₃ solution and 20 mL of (NH₄)₂S₂O₈ solution. If a beaker is used, cover it with a ribbed cover glass. Boil the solution 8 min to 10 min, maintaining the volume at 200 mL by additions of hot water. If the color due to permanganate ions does not develop, or develops but does not persist, add two drops of KMnO₄ solution (105.4), 5 mL more of AgNO₃ solution 20 mL more of (NH₄)₂S₂O₈ solution and boil for an additional 8 min to 10 min. Add hot water to maintain the volume at 200 mL during this operation and the operations that follow in 107.7.

107.7 Reduce the permanganate ions as follows: Add 5 mL of HCl (1 + 3) and continue boiling for 10 min after the disappearance of permanganate color. If the permanganate ions have not been completely reduced or if a precipitate of manganese dioxide (MnO₂) is present, add 2 mL of HCl (1 + 3) and boil again for 10 min. Repeat the addition of HCl and boiling until all manganese is present as colorless manganous ions. Cool to room temperature and dilute to 200 mL. If vanadium is present or its absence has not been confirmed, proceed as directed in 107.9. If vanadium is absent and the criteria of 103.2 are met, proceed as directed in 107.9. If vanadium is absent and the criteria of 103.2 are not met, or if potentiometric titration is preferred and vanadium is absent, proceed as directed in 107.10.

107.8 *Titration With Potassium Permanganate*—While swirling the flask, add one drop to two drops of 1,10 phenanthroline indicator solution and then add sufficient Fe(NH₄)₂(SO₄)₂ solution to effect a change in color from clear green to pink. Add 1 mL to 2 mL more and record the buret reading to the nearest 0.01 mL. Using a 25-mL buret, back-titrate the excess ferrous ions with 0.05 N KMnO₄ standard solution. Add KMnO₄ dropwise as the end point is approached. Continue the titration until the pink color has changed to clear green which persists for 60 s. Record the buret reading to the nearest 0.01 mL.

107.9 *Titration with Potassium Dichromate to the Diphenylamine Sulfonate End Point*—While swirling the flask, add Fe(NH₄)₂(SO₄)₂ solution from a 25-mL buret until the disappearance of the yellow color. Then add 1 mL to 2 mL in excess and record the buret reading to the nearest 0.01 mL. Add two drops of diphenylamine sulfonate indicator solution. Using another 25-mL buret, back-titrate the excess ferrous ions with 0.05 N K₂Cr₂O₇ standard solution. Add the K₂Cr₂O₇ solution dropwise as the end point is approached. Continue the titration until a blue color appears and persists for at least 30 s. Record the buret reading to the nearest 0.01 mL.

107.10 *Titration with Potassium Dichromate and Potentiometric End Point Detection*—Stir the sample solution in the 600-mL beaker with a magnetic stirrer and insert the saturated

calomel reference and platinum indicator electrodes. With the electrodes connected to the potentiometer apparatus, add from a 25-mL buret the Fe(NH₄)₂(SO₄)₂ solution while stirring until the yellow color disappears. Then add 1 mL to 2 mL in excess and record the buret reading to the nearest 0.01 mL. Using another 25-mL buret add 0.05 N K₂Cr₂O₇ standard solution in 0.1-mL increments recording the voltage after equilibrium for each increment. Inspect the data for the maximum voltage change between increments of standard dichromate solution (see 106.3). Determine the voltage change for the increments before and after the maximum change and interpolate the end point to the nearest 0.01 mL as described in 106.3.

108. Calculation

108.1 If KMnO₄ was used, calculate the percentage of chromium as follows:

$$\text{Chromium, \%} = [(AB - CD) \times 1.733] / E \quad (20)$$

where:

- A = Fe(NH₄)₂(SO₄)₂ solution, mL,
- B = normality of Fe(NH₄)₂(SO₄)₂ solution,
- C = KMnO₄ solution used, mL,
- D = normality of the KMnO₄ solution and
- E = sample taken, g.

108.2 If K₂Cr₂O₇ was used, calculate the percentage of chromium as follows:

$$\text{Chromium, \%} = [(AB - CD) \times 1.733] / E \quad (21)$$

where:

- A = Fe(NH₄)₂(SO₄)₂ solution, mL,
- B = normality of Fe(NH₄)₂(SO₄)₂ solution,
- C = K₂Cr₂O₇ solution, mL,
- D = normality of K₂Cr₂O₇ solution and
- E = sample taken, g.

109. Precision and Bias¹⁶

109.1 *Precision*—Nine laboratories cooperated in testing this test method and obtained the data summarized in Table 11. Although samples at the lower and midrange of the scope were not tested, the precision data for other types of alloys using the test methods indicated in Table 11 should apply.

¹⁶ Supporting data have been filed at ASTM International Headquarters and may be obtained by requesting Research Report RR:E03-1036.

TABLE 11 Statistical Information—Chromium

Test Specimen	Chromium Found, %	Repeatability (R ₁ , Practice E173)	Reproducibility (R ₂ , Practice E173)
1. No. 2, Test Methods E350	0.481	0.015	0.053
2. No. 2, Test Methods E351	1.96	0.10	0.16
3. No. 3, Test Methods E352	3.68	0.16	0.48
4. High-Temperature Alloy Waspalloy (NIST 349, 19.50 % Cr, certified)	19.46	0.25	0.49
5. High-Temperature Alloy 41Co, 20Ni, 20Cr (NIST 168, 20.33 % Cr, not certified)	20.26	0.35	0.57

109.2 *Bias*—The bias of this test method may be judged by comparing accepted reference values with the corresponding arithmetic average obtained by interlaboratory testing, such as the data listed in [Table 11](#).

MOLYBDENUM BY THE ION EXCHANGE— 8-HYDROXYQUINOLINE GRAVIMETRIC METHOD

110. Scope

110.1 This test method covers the determination of molybdenum from 1.5 % to 30 %.

111. Summary of Test Method

111.1 Molybdenum is separated from interfering elements on an anion-exchange resin column using a sequence of HF + HCl eluent solutions. The isolated molybdenum is precipitated with 8-hydroxyquinoline and weighed as the anhydrous complex.

112. Interferences

112.1 All interfering elements which are normally present are removed by the anion exchange separation.

113. Apparatus

113.1 *Ion Exchange Column, Polystyrene*,¹⁷ approximately 400 mm in length and 25 mm in inside diameter, the bottom tapered to a 2-mm bore outlet, fitted with a hosecock or stopcock to control the liquid flow. All parts of the apparatus must be constructed of HF-resistant plastic, such as polytetrafluoroethylene, polyethylene or polyvinyl chloride ([Note 31](#)).

NOTE 31—The ion exchange column system must be carefully assembled and checked to avoid possible leakage of solutions containing HF.

114. Reagents

114.1 *Ammonium Chloride Solution* (240 g/L)—Dissolve 240 g of ammonium chloride (NH₄Cl) in 800 mL of water. Warm to room temperature, dilute to 1 L and mix.

114.2 *Ammonium Fluoride* (NH₄F).

114.3 *Ammonium Oxalate* (NH₄OCOCOOH·H₂O).

114.4 *EDTA Solution* (10 g/L)—Dissolve 10 g of EDTA-sodium salt in water. Dilute to 1 L and mix.

114.5 *Eluent Solutions*—(**Warning**—HF causes serious burns which may not be immediately painful; read the paragraph about HF in the Safety Precautions section of [Practices E50](#).)

114.5.1 *HF/HCl/Water* (4 + 1 + 95)—To 800 mL of water in a 1-L polyethylene graduated cylinder, add 40 mL of HF and 10 mL of HCl; dilute to 1 L and mix. Store in an HF-resistant plastic bottle.

114.5.2 *HF/Hydrochloride Acid/Water* (1 + 5 + 4)—To 300 mL of water in a 1-L polyethylene graduated cylinder, add

100 mL of HF and 500 mL of HCl; dilute to 1 L and mix. Store in an HF-resistant plastic bottle.

114.5.3 *HF/HCl/Water* (20 + 25 + 55)—To 500 mL of water in a 1-L polyethylene graduated cylinder, add 200 mL of HF and 250 mL of HCl; dilute to 1 L and mix. Store in an HF-resistant plastic bottle.

114.5.4 *HF/Ammonium Chloride/Water* (4 + 60 + 36)—To 600 mL of ammonium chloride solution (240 g/L) in a 1-L polyethylene graduated cylinder, add 40 mL HF; dilute to 1 L and mix. Store in an HF-resistant plastic bottle. (This solution is 14.4 % in NH₄Cl on a weight/volume basis.)

114.5.5 *Ammonium Fluoride/Ammonium Chloride Solution*—To 600 mL of ammonium chloride solution (240 g/L) in a 1-L polyethylene graduated cylinder, add 41 g of NH₄F. Add water to the 900-mL mark and stir to dissolve. Dilute to 1 L and mix. With narrow-range pH paper, verify that the pH is between 5.6 and 5.8. If it is above this range, adjust the solution with dropwise additions of HF; if it is below this range, adjust the solution with dropwise additions of NH₄OH. Store in an HF-resistant plastic bottle. (This solution is 14.4 % in NH₄Cl and 5.1 % in NH₄F on a weight/volume basis.)

114.6 *8-Hydroxyquinoline Solution* (30 g/L)—Dissolve 30 g of 8-hydroxyquinoline in 120 mL of glacial acetic acid (CH₃COOH). Cautiously add water, with stirring to a total solution volume of 600 mL. Warm to 40 °C. Add NH₄OH (1 + 1) dropwise with stirring until a slight permanent precipitate is formed. Carefully add glacial CH₃COOH with stirring until the precipitate first dissolves. Dilute to 1 L.

114.7 *Ion-Exchange Resin:*

114.7.1 Use an anion-exchange resin of the alkyl quaternary ammonium type (chloride form) consisting of spherical beads having a cross-linkage of 8 % and of (200 to 400) nominal U.S. mesh size.¹⁸ To remove those beads greater than about 180 μm in diameter, as well as the very small diameter beads, treat the resin as follows: Transfer a supply of the resin to a beaker, cover with water and allow at least 30 min for the beads to undergo maximum swelling. Place a No. 80 (180-μm) screen, 150 mm in diameter, over a 2-L beaker. Prepare a thin slurry of the resin and pour it into the screen. Wash the fine beads through the screen using a small stream of water. Discard the beads retained on the screen periodically to avoid undue clogging of the openings. When the bulk of the resin has settled in the 2-L beaker, decant the water and transfer approximately 100 mL of resin to a 400-mL beaker. Add 200 mL of HCl (1 + 19) and stir vigorously. Allow the resin to settle for 4 min to 6 min, decant 150 mL to 175 mL of the suspension, and discard. Repeat the treatment with HCl (1 + 19) twice more and reserve the coarser resin for the column preparation.

114.7.2 Prepare the column as follows: Place a 10-mm to 20-mm layer of polyvinyl chloride plastic fiber¹⁹ in the bottom of the column, and add a sufficient amount of the prepared resin to fill the column to a height of approximately 150 mm to

¹⁷ Columns available from Ledoux & Co., Inc., Teaneck, NJ, have been found satisfactory for this purpose.

¹⁸ AG1-X8, 200 to 400 mesh, chloride form, available from Bio-Rad Laboratories, Richmond, CA, has been found satisfactory for this purpose.

¹⁹ Dynel plastic wool available from Union Carbide Corp., Chemical Division, Textile Fibers Dept., Needham Heights, MA, has been found satisfactory for this purpose.

175 mm. Place a 20-mm layer of polyvinyl chloride plastic fiber on the top of the resin surface to protect it from being carried into suspension when the solutions are added. Add 100 mL to 125 mL of HCl (3 + 1) to the column. When the solution level is 5 mm to 10 mm above the top of the resin bed add 100 mL of HCl (1 + 9) to the column. Repeat this cycle twice more and finally wash the resin bed with 200 mL HCl (1 + 3) turning off the stopcock when the solution level is 10 mm to 20 mm above the top of the resin bed.

114.8 *Sodium Hydroxide Solution* (100 g/L)—Dissolve 100 g of NaOH in about 100 mL of water. Cool and dilute to 1 L. Store in a plastic bottle.

114.9 *Sodium Hydroxide Solution* (10 g/L)—Dissolve 10 g of NaOH in about 100 mL of water. Cool and dilute to 1 L. Store in a plastic bottle.

115. Procedure

115.1 Transfer 1 g of sample weighed to the nearest 0.1 mg to a 200-mL polytetrafluoroethylene beaker marked at the 100-mL level on the outside. Add 10 mL of HF and cover with a polytetrafluoroethylene watchglass. Warm the solution with low heat and cautiously add HNO₃ in 1-mL increments allowing the reaction to subside between additions. High chromium samples may also require cautious dropwise additions of HCl. When dissolution is complete, cool the beaker, remove the cover with platinum-tipped tongs and cautiously rinse it into the solution with water.

115.2 Over a steambath or other low-temperature arrangement evaporate the solution to dryness. Cool, wash down the sides of the beaker with HCl (1 + 1) and again evaporate to dryness over low heat. Cool, add 5 mL HF and 25 mL water. Warm over low heat until all salts are dissolved (Note 32). Cool to room temperature and dilute to 100 mL with water.

NOTE 32—It may be necessary to add additional water and to stir cautiously with a polytetrafluoroethylene stirring rod to completely dissolve all salts.

115.3 Drain the solution in the ion exchange column by passing 100 mL of HF/HCl/water (4 + 1 + 95) through it at a rate of approximately 2 mL/min. Allow the solution to drain to the top of the resin bed. Collect the effluent in a plastic beaker and discard it.

115.4 Place an 800-mL plastic beaker under the column. Place a small plastic funnel holding a high-porosity hard-surface filter paper in the top of the column. Ensure that an air seal does not form between the funnel and the column. Cautiously filter the sample solution onto the column. Adjust the effluent flow to about 2 mL/min. Rinse the beaker with HF/HCl/water (4 + 1 + 95) transferring the washings to the paper. Cautiously police the beaker with a polytetrafluoroethylene policeman, if necessary, and rinse onto the paper with HF/HCl/water (4 + 1 + 95). Wash the paper well with HF/HCl/water (4 + 1 + 95). Cautiously, remove and discard paper (Note 33).

NOTE 33—If insoluble molybdenum compounds are suspected or known to be present, halt the flow from the column when the washing of the paper is complete. Cautiously transfer the paper to a platinum crucible and ignite at 500 °C (no higher) in a muffle furnace. Cool in a desiccator,

add 1 g anhydrous sodium carbonate powder (Na₂CO₃) and fuse over a burner. Cool, add 20 mL water and heat to dissolve the melt. Carefully acidify with dropwise additions of HCl (1 + 4) until effervescence ceases plus ten drops excess. Evaporate to dryness, cool, add 20 mL HF/HCl/water (4 + 1 + 95), heat to dissolve, cool and transfer this solution to the column. Resume the 2-mL/min flow from the column.

115.5 Continue to add HF/HCl/water (4 + 1 + 95) until 650 mL have been collected in the 800-mL plastic beaker (Note 34). Drain the solution to the top of the resin bed. Cautiously discard this solution.

NOTE 34—This solution contains all the iron, chromium, nickel, cobalt, aluminum, copper and manganese.

115.6 Place an 800-mL plastic beaker under the column and elute 500 mL of HF/HCl/water (1 + 5 + 4) at a rate of 2 mL/min. Drain the solution to the top of the resin bed. Cautiously discard this solution (Note 35).

NOTE 35—This solution contains all the tungsten, titanium, zirconium and hafnium.

115.7 Place an 800-mL polytetrafluoroethylene beaker under the column and elute the molybdenum with 500 mL of HF/HCl/water (20 + 25 + 55) at a rate of 2 mL/min. Drain the solution to the top of the resin bed. Proceed with this eluent solution as described in 115.11.

115.8 Place an 800-mL plastic beaker under the column and elute 300 mL of HF/NH₄Cl/water (4 + 60 + 36) at a rate of 2 mL/min. Drain the solution to the top of the resin bed. Cautiously discard this solution (Note 36).

NOTE 36—This solution contains all the niobium.

115.9 Place an 800-mL plastic beaker under the column and elute 350 mL of NH₄F/NH₄Cl solution at a rate of 2 mL/min. Drain solution to the top of the resin bed. Cautiously discard this solution (Note 37).

NOTE 37—This solution contains all the tantalum.

115.10 Place an 800-mL plastic beaker under the column and elute 100 mL of water, then 100 mL of HCl (1 + 3), stopping the flow when the liquid level is 10 mm to 20 mm above the resin bed. Cautiously discard the solution. The column is now ready to be stored for future use or to be preconditioned for another sample (115.3).

115.11 To the eluent containing the molybdenum (from 115.7) cautiously add 15 mL of H₂SO₄ (1 + 1) and evaporate to light fumes on a steambath or other carefully controlled heat source. Ensure that the applied temperature does not exceed the softening point of polytetrafluoroethylene. Cool and cautiously rinse into a 400-mL borosilicate glass beaker. Heat to low volume (about 10 mL), cool, add 2 mL of HNO₃ and evaporate to strong fumes of SO₃.

115.12 Cool to room temperature, dilute to about 30 mL with water, add 5 mL of HNO₃ and 5 mL of HCl. Cover and heat for 10 min.

115.13 Dilute to 100 mL. Heat to boiling and while hot, cautiously add NaOH solution (100 g/L) until litmus paper moistened with the solution just turns blue, then add 10 mL excess. Boil for 1 min. If a precipitate is present, filter through high-porosity, surface-hardened filter paper and wash the paper

thoroughly with warm NaOH solution (10 g/L). Discard the paper. If no precipitate is present, proceed directly to 115.14.

115.14 If the molybdenum content of the solution or filtrate obtained in 115.13 is known to be less than 125 mg proceed to 115.15. If the molybdenum content of the solution or filtrate obtained in 115.13 is known to be greater than 125 mg, transfer the solution to a 250-mL volumetric flask, cool to room temperature, dilute to volume and mix. Transfer a 100-mL aliquot by pipet to a 400-mL borosilicate beaker (**PRECAUTION—Note 38**).

NOTE 38—Precaution—Minimize contact time of caustic solutions in volumetric glassware; wash glassware thoroughly immediately after use.

115.15 Adjust the volume of the solution in the 400-mL beaker to approximately 200 mL. Add 10 mL of EDTA solution (10 g/L) and 3 g of ammonium oxalate. Warm gently to obtain a clear solution and cool to room temperature. Adjust the pH to 4.0 using a pH meter and dropwise additions of HCl (1 + 1) and NaOH solution (10 g/L).

115.16 Heat the solution to boiling, remove from heat and slowly add 20 mL of 8-hydroxyquinoline solution (30 g/L) while stirring. Heat at just below the boiling point for 10 min, stirring occasionally.

115.17 Filter through a tared medium-porosity fritted glass filtering crucible using gentle suction. Wash the contents of the beaker into the filtering crucible with hot water and wash the precipitate with additional hot water for a total volume of about 100 mL.

115.18 Dry the precipitate in a drying oven set at 125 °C for at least 4 h. Cool the filtering crucible for at least 2 h in a desiccator and weigh.

116. Calculation

116.1 Calculate the percent of molybdenum as follows:

$$\text{Molybdenum, \%} = [(A - B) \times C \times 23.05] / D \quad (22)$$

where:

- A = weight of crucible plus precipitate, g,
- B = weight of crucible, g,
- C = aliquot factor (direct: $C = 1$, aliquot: $C = 2.5$) and
- D = sample weight, g.

117. Precision and Bias

117.1 *Precision*—Seven laboratories cooperated in testing this test method and obtained the data summarized in Table 12. The unavailability of appropriate test specimens at the upper limit of the scope necessitated the inclusion of Test Material 5 which is a different class of material. While the testing range exceeds the upper limit of the scope, the data for Test Material 5 suggests the precision at the upper limit of the scope is adequate.

117.2 *Bias*—No data are presently available to determine the accuracy of this method.

TABLE 12 Statistical Information—Molybdenum Ion Exchange—8-Hydroxyquinoline Gravimetric Method

Test Material	Molybdenum Found, %	Repeatability, (R_1 , Practice E173 ^A)	Reproducibility, (R_2 , Practice E173 ^A)
1. No. 1, Test Methods E351	1.48	0.070	0.086
2. Co-base alloy 43Co-21Ni-20Cr-5W-3Nb-2Fe-2Mn (NIST 167, 3.90 % Mo, not certified)	3.92	0.219	0.250
3. No. 3, Test Methods E352	8.85	0.180	0.188
4. Ni-base alloy 16Cr-5Fe-4W-Bal. Ni (AMS 5388, 17 % Mo, not certified)	17.49	0.285	0.641
5. Ferromolybdenum Balance Fe (FeMo-2, 53.20 % Mo)	52.70	1.21	2.34

^A This test method was performed in accordance with the 1980 version of Practice E173.

IRON BY THE SILVER REDUCTION TITRIMETRIC METHOD

118. Scope

118.1 This test method covers the determination of iron from 1.0 % to 50.0 %.

119. Summary of Test Method

119.1 The sample is dissolved in HCl and HNO₃ and fumed in HClO₄. Iron is precipitated with NH₄OH in the presence of ammonium peroxydisulfate. The precipitate is dissolved in HCl. The resulting solution is adjusted to dilute acidity and passed through a silver reductor. After addition of a mixture of H₃PO₄ and H₂SO₄ and sodium diphenylaminesulfonate indicator the sample is titrated with standard potassium dichromate solution.

120. Interferences

120.1 The elements normally present do not interfere if their contents are less than the maximum amounts shown in 1.1.

121. Apparatus

121.1 *Silver Reductor Column:*

121.1.1 *Preparation*—Use a glass column (2-cm diameter and 25-cm length) fitted with a stopcock and a reservoir cup (approximately 100-mL capacity). Lightly insert a glass wool plug above the stopper. Fill the column with a slurry of silver powder in HCl (1 + 11) and drain the acid solution to within 1 cm of the top of the column to produce a silver metal column of 17-cm length. Wash the column with 150 mL of HCl (1 + 11), allowing the acid solution to drain at a rate of about 30 mL/min. Store the column with 1 cm to 2 cm of HCl (1 + 11) above the top of the metal.

121.1.2 *Regeneration*—When a dark grey area extends down 10 cm from the top of the metal column, the column must be regenerated as follows. Pass 150 mL of H₂SO₄ (1 + 99) through the column at a rate of about 30 mL/min. Leave 1 cm of solution above the metal. Lower two zinc rods

(15 cm long) attached to cotton strings until they contact the silver metal and let stand overnight. Pass 50 mL of H₂SO₄ (1 + 1) through the column. Remove the zinc rods. Pass 150 mL of HCl (1 + 11) through the column at a rate of 30 mL/min. The column is now ready for reuse. Store the column with 1 cm to 2 cm of HCl (1 + 11) above the top of the metal.

NOTE 39—If the flow from the column slows significantly in use or if the liquid layer falls below the metal, the metal and glass wool must be removed and the column repacked. For this reason some laboratories may find it convenient to maintain two silver reductor columns.

122. Reagents

122.1 *Ammonium Peroxydisulfate*, (NH₄)₂S₂O₈.

122.2 *Potassium Dichromate, Standard Solution* (0.10 N)—Dissolve 4.9032 g of NIST standard potassium dichromate in water, transfer to a 1-L volumetric flask, dilute to volume and mix.

122.3 *Silver Powder*:

122.3.1 Use high-purity (99.9 % minimum purity) silver powder, 40 mesh to 60 mesh.

122.3.2 *Alternate*: Dissolve 100 g of silver nitrate (AgNO₃) in 400 mL of water in a 600-mL beaker. Add 10 mL of HNO₃. Place two zinc rods (15 cm in length) crosswise in the solution and let stand overnight. Remove the rods, washing them into the solution. Decant the supernatant solution and discard it. Add 400 mL H₂SO₄ (1 + 99) to the precipitated silver metal, stir well, allow to settle and discard the supernatant solution. Repeat the decantation until the supernatant solution is clear. The precipitated silver may be transferred to the glass column in this form, then washed with HCl (1 + 11), as described in 121.1.1.

122.4 *Sodium Diphenylaminesulfonate Indicator Solution* (2 g/L)—Dissolve 0.20 g of sodium diphenylaminesulfonate in 100 mL of water. Store in a dark glass bottle.

122.5 *H₂SO₄-H₃PO₄ Mixture*—Add 150 mL of H₃PO₄ to 400 mL of water, stirring well. Cool in a water bath and cautiously add 150 mL of H₂SO₄ while stirring well. Cool to room temperature and dilute to 1 L while cautiously cooling and stirring. Cool again to room temperature.

122.6 *Zinc Metal Rods* (approximately 8 mm in diameter and 150 mm in length), 99.9 % purity.

123. Procedure

123.1 Select a sample weight which is expected to contain 60 mg to 100 mg of iron (but not exceeding 3.0 g). Weigh the sample to the nearest 0.2 mg and transfer it to a 400-mL beaker. Add 25 mL of HCl and 25 mL of HNO₃ and heat to dissolve. Add four drops of HF to remove SiO₂. Cool and cautiously add 20 mL HClO₄. Heat to dense white fumes. Continue heating for 5 min to fully oxidize chromium.

123.2 Cool and dilute to 200 mL with water. Add NH₄OH slowly, while stirring, until the precipitate redissolves slowly, then add 25 mL additional NH₄OH and 2 g of ammonium peroxydisulfate. Boil carefully for 2 min and filter through a high-porosity filter paper, wash five times with NH₄OH (1 + 50). Discard the filtrate.

123.3 Place the original beaker under the funnel and dissolve the precipitate in 50 mL hot HCl (1 + 3). Wash the paper alternately with hot water and with hot HCl (1 + 3) until it is free of yellow iron color. Discard the paper.

NOTE 40—Several drops of H₂O₂, 30 %, added to the hot HCl (1 + 3) in the funnel will aid in dissolving the precipitate if a large amount of manganese is present.

123.4 Dilute the solution to 150 mL. Add NH₄OH cautiously, while stirring, until the precipitate redissolves slowly, then add 25 mL additional NH₄OH and 2 g ammonium peroxydisulfate. Boil carefully for 2 min and filter through a high-porosity filter paper,²⁰ wash five times with NH₄OH (1 + 50). Discard the filtrate.

123.5 Place the original beaker under the funnel and dissolve the precipitate in 50 mL hot HCl (1 + 3). Wash the paper alternately with hot water and with hot HCl (1 + 3) until it is free of yellow iron color. Discard the paper.

123.6 Boil the solution to reduce the volume to approximately 10 mL. Cool, dilute to 100 mL with water. Place a 600-mL beaker under the silver reductor column. Pass the solution through the column at a rate of approximately 35 mL/min. Rinse the 400-mL beaker three times with HCl (1 + 11) and add the rinsings to the column. Drain the solution to within 1 cm of the top of the silver metal, then add 150 mL of HCl (1 + 11) to the column, collecting all the eluent at approximately 35 mL/min in the 600-mL beaker. Retain a 1-cm layer of HCl (1 + 11) above the silver.

123.7 Add 25 mL of the H₂SO₄-H₃PO₄ mixture to the 600-mL beaker, then add five drops to six drops of sodium diphenylaminesulfonate indicator solution. Titrate immediately with potassium dichromate standard solution (0.10 N) to a permanent purple end point.

124. Calculation

124.1 Calculate the percent of iron as follows:

$$\text{Iron, \%} = [(0.55847) \times (A)/(B)] \quad (23)$$

where:

A = K₂Cr₂O₇ standard solution (0.1000 N), mL and
B = sample taken, g.

125. Precision and Bias

125.1 *Precision*—Six laboratories cooperated in testing this test method and obtained data summarized in Table 13. The precision data demonstrates that this test method is applicable between 0.5 % to 53 % iron well within the stated range, in the scope.

125.2 *Bias*—No information on the accuracy of this test method is known. The accuracy of this test method may be judged by the agreement between the certified reference values and the corresponding arithmetic average obtained by inter-laboratory testing (see Table 13).

²⁰ Whatman No. 541 filter paper has been found acceptable for this purpose.

TABLE 13 Statistical Information—Iron by the Silver Reduction Titrimetric Method

Sample	Certified, %	Iron Found %	Repeatability, (R_1 , Practice E173 ^A)	Reproducibility, (R_2 , Practice E173 ^A)
NIST 169 Ni Base	0.54	0.54	0.0179	0.0186
NIST 162a Cu-Ni	2.19	2.19	0.0317	0.0331
NIST 864 Inconel 600	9.6	9.62	0.0289	0.0688
NIST 161 Ni Base	15.01	15.00	0.1152	0.1260
NIST 348 A286	53.3	53.25	0.1653	0.2952

^A This test was performed in accordance with the 1980 version of Practice E173.

NIObIUM BY THE ION EXCHANGE—CUPFERRON GRAVIMETRIC METHOD

126. Scope

126.1 This test method covers the determination of niobium from 0.5 % to 6.0 %.

127. Summary of Test Method

127.1 Niobium is separated from interfering elements on an anion-exchange resin column using a sequence of HF + HCl eluent solutions. The isolated niobium is precipitated with cupferron, ignited to the oxide and weighed as niobium pentoxide (Nb₂O₅).

128. Interferences

128.1 All interfering elements which are normally present are removed by the anion exchange separation.

129. Apparatus

129.1 *Ion Exchange Column, Polystyrene*,²¹ approximately 400 mm in length and 25-mm in inside diameter, the bottom tapered to a 2-mm bore outlet, fitted with a hosecock or stopcock to control the liquid flow. All parts of the apparatus must be constructed of HF-resistant plastic, such as polytetrafluoroethylene, polyethylene or polyvinyl chloride (see 129.2).

129.2 The ion exchange column system must be carefully assembled and checked to avoid possible leakage of solutions containing HF.

130. Reagents

130.1 *Ammonium Chloride Solution (240 g/L)*—Dissolve 240 g of ammonium chloride (NH₄Cl) in 800 mL of water. Warm to room temperature, dilute to 1 L and mix.

130.2 *Ammonium Fluoride* (NH₄F).

130.3 *Boric Acid* (H₃BO₃).

130.4 *Cupferron Solution*—Dissolve 30 g of cupferron in 400 mL of water. Dilute to 500 mL and filter through a medium-porosity filter paper. Store in a refrigerator. Prepare

fresh weekly. (**Warning**—Cupferron is a known carcinogen. Use protective equipment and work in an efficient exhaust hood.)

130.5 *Eluent Solutions*—(**Warning**—HF causes serious burns which may not be immediately painful; see the Hazards section of Practices E50.)

130.5.1 *HF/HCl/Water (4 + 1 + 95)*—To 800 mL of water in a 1-L polyethylene graduated cylinder, add 40 mL of HF and 10 mL of HCl; dilute to 1 L and mix. Store in an HF-resistant plastic bottle.

130.5.2 *HF/HCl/Water (1 + 5 + 4)*—To 300 mL of water in a 1-L polyethylene graduated cylinder, add 100 mL of HF and 500 mL of HCl; dilute to 1 L and mix. Store in an HF-resistant plastic bottle.

130.5.3 *HF/HCl/Water (20 + 25 + 55)*—To 500 mL of water in a 1-L polyethylene graduated cylinder, add 200 mL HF and 250 mL HCl; dilute to 1 L and mix. Store in an HF-resistant plastic bottle.

130.5.4 *HF/Ammonium Chloride/Water (4 + 60 + 36)*—To 600 mL of ammonium chloride solution (240 g/L) in a 1-L polyethylene graduated cylinder, add 40 mL HF; dilute to 1 L and mix. Store in an HF-resistant plastic bottle. (This solution is 14.4 % in NH₄Cl on a weight/volume basis.)

130.5.5 *Ammonium Fluoride/Ammonium Chloride Solution*—To 600 mL of ammonium chloride solution (240 g/L) in a 1-L polyethylene graduated cylinder, add 41 g of NH₄F. Add water to the 900-mL mark and stir to dissolve. Dilute to 1 L and mix. With narrow-range pH paper, verify that the pH is between 5.6 and 5.8. If it is above this range, adjust the solution with dropwise additions of HF; if it is below this range, adjust the solution with dropwise additions of NH₄OH. Store in an HF-resistant plastic bottle. (This solution is 14.4 % in NH₄Cl and 4.1 % in NH₄F on a weight/volume basis.)

130.6 Ion-Exchange Resin:

130.6.1 Use an anion-exchange resin of the alkyl quaternary ammonium type (chloride form) consisting of spherical beads having a cross-linkage of 8 % and of (200 to 400) nominal U.S. mesh size.²² To remove those beads greater than about 1800 μm in diameter, as well as the very small diameter beads, treat the resin as follows: Transfer a supply of the resin to a beaker, cover with water, and allow at least 30 min for the beads to undergo maximum swelling. Place a No. 80 (180-μm) screen, 150 mm in diameter, over a 2-L beaker. Prepare a thin slurry of the resin and pour it into the screen. Wash the fine beads through the screen using a small stream of water. Discard the beads retained on the screen periodically to avoid undue clogging of the openings. When the bulk of the resin has settled in the 2-L beaker, decant the water and transfer approximately 100 mL of resin to a 400-mL beaker. Add 200 mL of HCl (1 + 19) and stir vigorously. Allow the resin to settle for 4 min to 6 min, decant 150 mL to 175 mL of the suspension and discard. Repeat the treatment with HCl (1 + 19) twice more and reserve the coarser resin for the column preparation.

²¹ Columns available from Ledoux & Co., Inc., Teaneck, NJ, have been found satisfactory for this purpose.

²² AG1-X8, 200 mesh to 400 mesh, chloride form, which is available from Bio-Rad Laboratories, Richmond, CA, has been found satisfactory for this purpose.

130.6.2 Prepare the column as follows: Place a 10-mm to 20-mm layer of plastic fiber²³ in the bottom of the column and add a sufficient amount of the prepared resin to fill the column to a height of approximately 150 mm to 175 mm. Place a 20-mm layer of plastic fiber on the top of the resin surface to protect it from being carried into suspension when the solutions are added. Add 100 mL to 125 mL of HCl (3 + 1) to the column. When the solution level is 5 mm to 10 mm above the top of the resin bed add 100 mL of HCl (1 + 9) to the column. Repeat this cycle twice more and finally wash the resin bed with 200 mL HCl (1 + 3) turning off the stopcock when the solution level is 10 mm to 20 mm above the top of the resin bed.

131. Procedure

131.1 Transfer 1 g of sample weighed to the nearest 0.1 mg to a 200-mL polytetrafluoroethylene beaker marked at the 100-mL level on the outside. Add 10 mL of HF and cover with a polytetrafluoroethylene watchglass. Warm the solution with low heat and cautiously add HNO₃ in 1-mL increments allowing the reaction to subside between additions. High-chromium samples may also require cautious dropwise additions of HCl. When dissolution is complete, cool the beaker, remove the cover with platinum-tipped tongs and cautiously rinse it into the solution with water.

131.2 Over a steam bath or other low-temperature arrangement evaporate the solution to dryness. Cool, wash down the sides of the beaker with HCl (1 + 1) and again evaporate to dryness over low heat. Cool and add 5 mL of HF and 25 mL of water. Warm over low heat until all salts are dissolved (Note 41). Cool to room temperature and dilute to 100 mL with water.

NOTE 41—It may be necessary to add additional water and to stir cautiously with a polytetrafluoroethylene stirring rod to completely dissolve all salts.

131.3 Drain the solution in the ion exchange column and pass 100 mL of HF/HCl/water (4 + 1 + 95) through it at a rate of approximately 2 mL/min. Allow the solution to drain to the top of the resin bed. Collect the effluent in a plastic beaker and discard it.

131.4 Place an 800-mL plastic beaker under the column. Place a small plastic funnel holding a high-porosity hard-surfaced filter paper in the top of the column. Ensure that an air seal does not form between the funnel and the column. Cautiously filter the sample solution onto the column. Adjust the effluent flow to about 2 mL/min. Rinse the beaker with HF/HCl/water (4 + 1 + 95) transferring the washings to the paper. Cautiously police the beaker with a polytetrafluoroethylene policeman, if necessary, and rinse onto the paper with HF/HCl/water (4 + 1 + 95). Wash the paper well with HF/HCl/water (4 + 1 + 95). Cautiously, remove and discard paper (Note 42).

NOTE 42—If insoluble niobium compounds are suspected or known to be present, halt the flow from the column when the washing of the paper is complete. Cautiously transfer the paper to a platinum crucible and ignite

at 1000 °C in a muffle furnace. Cool in a desiccator, add 1 g anhydrous sodium carbonate powder (Na₂CO₃) and fuse over a burner with a platinum lid. Cool, add 20 mL of water and heat to dissolve the melt. Carefully acidify with dropwise additions of HCl (1+4) until effervescence ceases plus ten drops excess. Evaporate to dryness, cool, add 20 mL HF/HCl/water (4 + 1 + 95), heat to dissolve, cool and transfer this solution to the column. Resume the 2-mL/min flow from the column.

131.5 Continue to add HF/HCl/water (4 + 1 + 95) until 650 mL have been collected in the 800-mL plastic beaker (Note 43). Drain the solution to the top of the resin bed. Cautiously discard this solution.

NOTE 43—This solution contains all the iron, chromium, nickel, cobalt, aluminum, copper and manganese.

131.6 Place an 800-mL plastic beaker under the column and elute 500 mL of HF/HCl/water (1 + 5 + 4) at a rate of 2 mL/min. Drain the solution to the top of the resin bed. Cautiously discard this solution (Note 44).

NOTE 44—This solution contains all the tungsten, titanium, zirconium and hafnium.

131.7 Place an 800-mL polytetrafluoroethylene beaker under the column and elute 500 mL of HF/HCl/water (20 + 25 + 55) at a rate of 2 mL/min. Drain the solution to the top of the resin bed. Cautiously discard this solution (Note 45).

NOTE 45—This solution contains all the molybdenum.

131.8 Place an 800-mL plastic beaker under the column and elute the niobium with 300 mL of HF/NH₄Cl/water (4 + 60 + 36) at a rate of 2 mL/min. Drain the solution to the top of the resin bed. Proceed with this eluent as described in 131.11.

131.9 Place an 800-mL plastic beaker under the column and elute 350 mL of NH₄F/NH₄Cl solution at a rate of 2 mL/min. Drain solution to the top of the resin bed. Cautiously discard this solution (Note 46).

NOTE 46—This solution contains all the tantalum.

131.10 Place an 800-mL plastic beaker under the column and elute 100 mL of water, then 100 mL of HCl (1 + 3), stopping the flow when the liquid level is 10 mm to 20 mm above the resin bed. Cautiously discard the solution. The column is now ready to be stored for future use or to be preconditioned for another sample (see 131.3).

131.11 Weigh 15 g of H₃BO₃ into a 250-mL beaker, add 150 mL HCl (1 + 1) and heat to boiling. When dissolved, add the hot solution cautiously, with stirring, to the eluent containing the niobium (from 131.8).

131.12 Cool the solution in an icebath to approximately 5 °C. Add with stirring 15 mL of cold cupferron solution for each 10 mg of niobium expected to be present in the sample. Filter the precipitate using low-porosity filter paper and a vacuum filtration apparatus. Police the beaker well and rinse with cold HCl (1 + 19). Wash the paper with cold HCl (1 + 19).

131.13 Transfer the paper to a 600-mL borosilicate glass beaker. Add 100 mL of HNO₃, then 60 mL of H₂SO₄ (1 + 1), then 10 mL of HClO₄. Boil to reduce volume to approximately 50 mL, then heat strongly until organic material has been destroyed and heavy fumes of HClO₄ are evolved. Cool to

²³ SEF modacrylic fiber available from Monsanto Chemical Co., P.O. Box 2204, Decatur, AL 35609-2204, has been found satisfactory for this purpose.

room temperature, add two drops HF and heat to strong fumes of HClO₄. Fume for 1 min.

131.14 Cool to room temperature. Dilute to 250 mL with water and cool in an ice bath. Add, with stirring, 15 mL of cold cupferron solution for each 10 mg of niobium expected to be present in the sample. Filter the precipitate using low-porosity filter paper and a vacuum filtration apparatus. Police the beaker well and rinse with cold HCl (1 + 19). Wash the paper with cold HCl (1 + 19).

131.15 Transfer the paper to a large tared platinum or porcelain crucible. Press a small filter paper down over the crucible and precipitate and dry under a heat lamp in a hood for approximately 2 h.

131.16 Char in a muffle furnace in a hood at 550 °C, then raise the temperature to 1000 °C and ignite for 1 h. Cool in a desiccator and weigh as Nb₂O₅.

132. Calculation

132.1 Calculate the percentage of niobium as follows:

$$\text{Niobium, \%} = [(A - B) \times 69.904]/C \quad (24)$$

where:

- A = weight of crucible plus oxide, g,
- B = weight of crucible, g and
- C = sample weight, g.

133. Precision and Bias²⁴

133.1 *Precision*—Six laboratories participated in the testing of this test method, providing seven sets of data. The obtained precision is summarized in Table 14.

²⁴ Supporting data have been filed at ASTM International Headquarters and may be obtained by requesting Research Report RR:E01-1014.

TABLE 14 Statistical Information—Niobium

Test Material	Niobium Found, %	Repeat-ability (R ₁ , Practice E173)	Repro-ducibility (R ₂ , Practice E173)	Number of Laboratories ^A
1. Nickel-base alloy (53Ni, 19Cr, 18Fe, 3Mo, 1Ti) (5.48 % Nb, estimated)	5.47	0.14	0.15	7
2. BCS 351 (53Ni, 18Cr, 18Fe, 3Mo, 1Ti) (5.20 % Nb, certified)	5.20	0.36	0.36	7
3. BAM 328-1 (42Co, 21Cr, 20Ni, 4Mo, 4W, 2Fe, 1Mn, 1Si) (3.61 % ± 0.22 % Nb, certified)	3.72	0.08	0.28	7
4. NIST SRM 168 (41Co, 20Cr, 20Ni, 4Mo, 4W, 3Fe, 2Mn, 1Si) (2.95 % Nb, certified)	2.98	0.11	0.25	7
5. NIST SRM 1203 (76Ni, 12Cr, 4Al, 3Mo, 1Ti, 1Si) (1.00 % Nb, certified)	1.00	0.09	0.31	7
6. NIST SRM 123 (70Fe, 18Cr, 11Ni) (0.433 % Nb, certified)	0.46	0.08	0.15	6

^A Number of independent data sets.

133.2 *Bias*—The bias of this test method may be judged by comparing accepted reference values with the corresponding arithmetic average obtained by interlaboratory testing, such as the data listed in Table 14.

TANTALUM BY THE ION EXCHANGE—PYROGALLOL SPECTROPHOTOMETRIC METHOD

134. Scope

134.1 This test method covers the determination of tantalum from 0.03 % to 1.0 %.

135. Summary of Test Method

135.1 Tantalum is separated from interfering elements on an anion-exchange resin column using a sequence of HF + HCl eluent solutions. The isolated tantalum is further purified with a cupferron separation. The ignited and fused residue is reacted with pyrogallol in the presence of ammonium oxalate. Spectrophotometric measurements are made at 415 nm.

136. Interferences

136.1 All interfering elements which are normally present are removed by the anion exchange separation and the cupferron precipitation.

137. Apparatus

137.1 *Ion Exchange Column, Polystyrene*,²⁵ approximately 400 mm in length and 25 mm in inside diameter, the bottom tapered to a 2-mm bore outlet, fitted with a hosecock or stopcock to control the liquid flow. All parts of the apparatus must be constructed of HF-resistant plastic, such as polytetrafluoroethylene, polyethylene or polyvinyl chloride (Note 47).

NOTE 47—The ion exchange column system must be carefully assembled and checked to avoid possible leakage of solutions containing HF.

138. Reagents

138.1 *Ammonium Chloride Solution* (240 g/L)—Dissolve 240 g of NH₄Cl in 800 mL of water. Warm to room temperature, dilute to 1 L and mix.

138.2 *Ammonium Fluoride* (NH₄F).

138.3 *Ammonium Oxalate Solution* (40 g/L) —Dissolve 40 g of NH₄OCOCOOH in 800 mL of warm water, dilute to 1 L and mix.

138.4 *Boric Acid* (H₃BO₃).

138.5 *Cupferron Solution* (60 g/L) —Dissolve 30 g cupferron in 400 mL of water. Dilute to 500 mL and filter through a medium-porosity filter paper. Store in a refrigerator. Prepare fresh weekly. (**Warning**—Cupferron is a known carcinogen. Use protective equipment and work in an efficient exhaust hood.)

²⁵ Columns available from Ledoux & Co., Inc., Teaneck, NJ have been found satisfactory for this purpose.

138.6 *Eluent Solutions*—(**Warning**—HF causes serious burns which may not be immediately painful; see the paragraph about HF in the Hazards section of Practices E50.)

138.6.1 *HF/HCl/Hydrochloric Acid/Water*(4 + 1 + 95)—To 800 mL of water in a 1-L polyethylene graduated cylinder, add 40 mL of HF and 10 mL of HCl; dilute to 1 L and mix. Store in HF-resistant plastic bottle.

138.6.2 *HF/HCl/Water*(1 + 5 + 4)—To 300 mL of water in a 1-L polyethylene graduated cylinder, add 100 mL of HF and 500 mL of HCl; dilute to 1 L and mix. Store in an HF-resistant plastic bottle.

138.6.3 *HF/HCl/Water*(20 + 25 + 55)—To 500 mL of water in a 1-L polyethylene graduated cylinder, add 200 mL HF and 250 mL HCl; dilute to 1 L and mix. Store in an HF-resistant plastic bottle.

138.6.4 *HF/Ammonium Chloride/Water*(4 + 60 + 36)—To 600 mL of ammonium chloride solution (240 g/L) in a 1-L polyethylene graduated cylinder, add 40 mL HF; dilute to 1 L and mix. Store in an HF-resistant plastic bottle. (This solution is 14.4 % in NH₄Cl on a weight/volume basis.)

138.6.5 *Ammonium Fluoride/Ammonium Chloride Solution*—To 600 mL of ammonium chloride solution (240 g/L) in a 1-L polyethylene graduated cylinder, add 41 g of NH₄F. Add water to the 900 mL mark and stir to dissolve. Dilute to a 1 L and mix. With narrow-range pH paper, verify that the pH is between 5.6 and 5.8. If it is above this range, adjust the solution with dropwise additions of HF; if it is below this range, adjust the solution with dropwise additions of NH₄OH. Store in an HF-resistant plastic bottle. (This solution is 14.4 % in NH₄Cl and 4.1 % in NH₄F on a weight/volume basis.)

138.7 *Potassium Pyrosulfate* (K₂S₂O₇).

138.8 *Pyrogallol Solution*—Dissolve 4.5 g of stannous chloride (SnCl₂·2H₂O) in 35 mL of HCl. Add 150 mL of hot water and 50 g of pyrogallol. Stir until dissolved, dilute to 250 mL with water and filter through low-porosity filter paper. Prepare fresh on day of use.

138.9 *Tantalum Standard Solution* (1 mL = 0.1 mg Ta)—Weigh 0.1000 g of high purity tantalum metal to a 400-mL polytetrafluoroethylene beaker. Add 20 mL HF, then, cautiously dropwise HNO₃ while warming gently, until dissolved. Cool to room temperature, transfer to a 1-L plastic volumetric flask; dilute to the mark and mix. Store in a plastic bottle.

138.10 *Zirconium Carrier Solution* (1 mL = 5 mg Zr)—Weigh 0.27 g of zirconium oxide (ZrO₂) (purity 99.9 % minimum) into a 250-mL borosilicate glass beaker. Add 30 mL of H₂SO₄ (1+1) and heat to fumes. Fume for several minutes. Cool to room temperature. If not completely dissolved, cautiously add 1 mL of HCl and heat again to fumes; repeat until dissolved. Cool to room temperature and cautiously dilute to 40 mL with water. A more rapid alternate procedure is to weigh 1.7663 g of zirconium oxychloride-8 hydrate (ZrOCl₂·8H₂O) (purity 99.9 % minimum) into a 250-mL beaker, add 15 mL HCl to dissolve, transfer to a 100-mL volumetric flask and dilute to the mark and mix.

138.11 *Ion-Exchange Resin*:

138.11.1 Use an anion-exchange resin of the alkyl quaternary ammonium type (chloride form) consisting of spherical beads having a cross-linkage of 8 % and of (200 to 400) nominal U.S. mesh size.²⁶ To remove those beads greater than about 1800 μm in diameter, as well as the very small diameter beads, treat the resin as follows: Transfer a supply of the resin to a beaker, cover with water and allow at least 30 min for the beads to undergo maximum swelling. Place a No. 80 (180-μm) screen, 150 mm in diameter, over a 2-L beaker.

138.11.1.1 Prepare a thin slurry of the resin and pour it onto the screen. Wash the fine beads through the screen using a small stream of water. Discard the beads retained on the screen periodically to avoid undue clogging of the openings. When the bulk of the resin has settled in the 2-L beaker, decant the water and transfer approximately 100 mL of resin to a 400-mL beaker. Add 200 mL of HCl (1 + 19) and stir vigorously. Allow the resin to settle for 4 min to 6 min, decant 150 mL to 175 mL of the suspension, and discard. Repeat the treatment with HCl (1 + 19) twice more, and reserve the coarser resin for the column preparation.

138.11.2 Prepare the column as follows: Place a 10-mm to 20-mm layer of polyvinyl chloride plastic fiber²⁷ in the bottom of the column and add a sufficient amount of the prepared resin to fill the column to a height of approximately 150 mm to 175 mm. Place a 20-mm layer of polyvinyl chloride plastic fiber on the top of the resin surface to protect it from being carried into suspension when the solutions are added. Add 100 mL to 125 mL of HCl (3 + 1) to the column. When the solution level is 5 mm to 10 mm above the top of the resin bed add 100 mL of HCl (1 + 9) to the column. Repeat this cycle twice more and finally wash the resin bed with 200 mL HCl (1 + 3) turning off the stopcock when the solution level is 10 mm to 20 mm above the top of the resin bed.

139. Preparation of Calibration Curve

139.1 *Calibration Solutions*:

139.1.1 Prepare six 600-mL borosilicate glass beakers, each containing 250 mL of H₂SO₄ (1 + 8). Using pipets, transfer (1.00, 2.00, 5.00, 10.00, 15.00, and 20.00) mL of tantalum standard solution to the respective beakers. Add 2 mL of zirconium carrier solution, stir and cool in an icebath.

139.1.2 Add, with stirring, 15 mL of cold cupferron solution. Filter the precipitate using low-porosity filter paper and a vacuum filtration apparatus. Police the beaker well and rinse with cold HCl (1 + 19). Wash the paper with cold HCl (1 + 19).

139.1.3 Transfer the papers to 50-mL platinum or porcelain crucibles. Dry for 1 h under a heat lamp in a hood. Char in a muffle furnace in a hood at 550 °C. Raise the temperature to 650 °C and ignite for 2 h. Cool in a desiccator.

139.1.4 Add 2.0 g of potassium pyrosulfate and fuse over a burner, swirling the crucible to ensure that all residue dissolves. Cool, transfer the crucibles to 150-mL beakers, add 50 mL of ammonium oxalate solution and heat to dissolve the

²⁶ AG1-X8, (200–400) mesh, chloride form, which is available from Bio-Rad Laboratories, Richmond, CA, has been found satisfactory for this purpose.

²⁷ SEF modacrylic fiber available from Monsanto Chemical Co., P.O. Box 2204, Decatur, AL 35609-2204, has been found satisfactory for this purpose.

fused salt. Rinse the crucibles into the beakers with ammonium oxalate solution. Cool solutions to room temperature.

139.2 *Reagent Blank Solution*—Prepare a 600-mL borosilicate glass beaker containing 250 mL of H₂SO₄ (1 + 8). Add 2 mL of zirconium carrier solution, stir, cool in an icebath and treat as in 139.1.2 – 139.1.4.

139.3 *Color Development:*

139.3.1 Transfer 20.00 mL of pyrogallol solution by means of a pipet to each of six, 100-mL volumetric flasks. Transfer the solutions from 139.1 and 139.2 into the respective flasks, rinsing the beakers with ammonium oxalate solution into the flasks. Dilute each flask to the mark with ammonium oxalate solution and mix.

139.4 *Spectrophotometry:*

139.4.1 *Multiple-Cell Spectrophotometer*—Measure the cell correction using water in the absorption cells with a 1-cm light path and using a light band centered at 415 nm. Wait 15 min for full color development after final dilution, then using the test cell, take absorbance readings of the reagent blank solution and of the calibration solutions versus water in the reference cell. Readings shall be taken within 1 h of full color development.

139.4.2 *Single-Cell Spectrophotometer*—Wait 15 min for full color development after final dilution, then with water in the absorption cell, with a 1-cm light path, adjust the spectrophotometer to the initial setting, using a light band centered at 415 nm. While maintaining this adjustment, take the absorbance readings of the reagent blank solution and of the calibration solutions. Readings should be taken within 1 h of full color development.

139.5 *Calibration Curve*—Subtract the cell-corrected reagent blank absorbance reading from each of the cell-corrected calibration solution absorbance readings. Plot these net absorbance readings against milligrams of tantalum per 100 mL of solution.

140. Procedure

140.1 Transfer 1 g of sample weighed to the nearest 0.1 mg to a 200-mL polytetrafluoroethylene beaker marked at the 100 mL level on the outside. Add 10 mL of HF and cover with a polytetrafluoroethylene watchglass. Warm the solution with low heat and cautiously add HNO₃ in 1-mL increments allowing the reaction to subside between additions. High chromium samples may also require cautious dropwise additions of HCl. When dissolution is complete, cool the beaker, remove the cover with platinum-tipped tongs and cautiously rinse it into the solution with water.

140.2 Over a steambath or other low temperature arrangement evaporate the solution to dryness. Cool, wash down the sides of the beaker with HCl (1 + 1) and again evaporate to dryness over low heat. Cool, add 5 mL HF and 25 mL water. Warm over low heat until all salts are dissolved (Note 48). Cool to room temperature and dilute to 100 mL with water.

NOTE 48—It may be necessary to add additional water and to stir cautiously with a polytetrafluoroethylene stirring rod to completely dissolve all salts.

140.3 Drain the solution in the ion exchange column by passing 100 mL of HF/HCl water (4 + 1 + 9) through it at a rate of approximately 2 mL/min. Allow the solution to drain to the top of the resin bed. Collect the effluent in a plastic beaker and discard it.

140.4 Place an 800-mL plastic beaker under the column. Place a small plastic funnel holding a high-porosity hard-surface filter paper in the top of the column. Ensure that an air seal does not form between the funnel and the column. Cautiously filter the sample solution onto the column. Adjust the effluent flow to about 2 mL/min. Rinse the beaker with HF/HCl/water (4 + 1 + 95) transferring the washings to the paper. Cautiously police the beaker with a polytetrafluoroethylene policeman, if necessary, and rinse onto the paper with HF/HCl/water (4 + 1 + 95). Wash the paper well with HF/HCl/water (4 + 1 + 95). Cautiously, remove and discard paper (Note 49).

NOTE 49—If insoluble tantalum compounds are suspected or known to be present, halt the flow from the column when the washing of the paper is complete. Cautiously transfer the paper to a platinum crucible and ignite at 1000 °C in a muffle furnace. Cool in a desiccator, add 1 g anhydrous sodium carbonate powder (Na₂CO₃) and fuse over a burner. Cool, add 20 mL water and heat to dissolve the melt. Carefully acidify with dropwise additions of HCl (1 + 4) until effervescence ceases plus ten drops excess. Evaporate to dryness, cool, add 20 mL HF/HCl/water (4 + 1 + 95), heat to dissolve, cool and transfer this solution to the column. Resume the 2 mL/min flow from the column.

140.5 Continue to add HF/HCl/water (4 + 1 + 95) until 650 mL have been collected in the 800-mL plastic beaker (Note 50). Drain solution to the top of the resin bed. Cautiously discard this solution.

NOTE 50—This solution contains all the iron, chromium, nickel, cobalt, aluminum, copper and manganese.

140.6 Place an 800-mL plastic beaker under the column and elute 500 mL of HF/HCl/water (1 + 5 + 4) at a rate of 2 mL/min. Drain solution to the top of the resin bed. Cautiously discard this solution (Note 51).

NOTE 51—This solution contains all the tungsten, titanium, zirconium and hafnium.

140.7 Place an 800-mL polytetrafluoroethylene beaker under the column and elute 500 mL of HF/HCl/water (20 + 25 + 55) at a rate of 2 mL/min. Drain solution to the top of the resin bed. Cautiously discard this solution (Note 52).

NOTE 52—This solution contains all the molybdenum.

140.8 Place an 800-mL plastic beaker under the column and elute 300 mL of HF/NH₄Cl/water (4 + 60 + 36) at a rate of 2 mL/min. Drain solution to the top of the resin bed. Cautiously discard this solution (Note 53).

NOTE 53—This solution contains all the niobium.

140.9 Place an 800-mL plastic beaker under the column and elute the tantalum with 350 mL of NH₄F/NH₄Cl solution at a rate of 2 mL/min. Drain solution to the top of the resin bed. Proceed with this eluent solution as described in 140.11. Take 350 mL of NH₄F/NH₄Cl solution and proceed with it as a blank, as described in 140.11.

140.10 Place an 800-mL plastic beaker under the column and elute 100 mL of water, then 100 mL of HCl (1 + 3);

TABLE 15 Statistical Information—Tantalum

Test Material	Tantalum Found, %	Repeatability (R_1 , Practice E173 ^A)	Reproducibility (R_2 , Practice E173 ^A)	Number of Laboratories ^B
1. NIST SRM 168 (41Co, 20Cr, 20Ni, 4Mo, 4W, 3Fe, 2Mn, 1Si) (0.95 % Ta, certified)	0.94	0.18	0.21	7
2. NIST 1203 (76Ni, 12Cr, 4Al, 3Mo, 1Ti, 1Si) (0.34 % Ta, certified)	0.35	0.10	0.10	7
3. BAM 328-1 (42Co, 21Cr, 20Ni, 4Mo, 4W, 2Fe, 1Mn, 1Si) (0.18 % Ta, certified)	0.17	0.04	0.08	7
4. NIST SRM 123 (70Fe, 18Cr, 11Ni) (0.027 % Ta, certified)	0.028	0.007	0.009	5
5. Nickel-base alloy (53Ni, 19Cr, 18Fe, 3Mo, 1Ti) (0.012 % Ta, estimated)	0.010	0.006	0.008	4

^A This test was performed in accordance with the 1992 version of Practice E173.

^B Number of independent data sets.

stopping the flow when the liquid level is 10 mm to 20 mm above the resin bed. Cautiously discard the solution. The column is now ready to be stored for future use or to be preconditioned for another sample.

140.11 Weigh 8 g of boric acid into a 250-mL beaker, add 150 mL HCl (1 + 1) and heat to boiling. When dissolved, add the hot solution cautiously, with stirring, to the eluent containing the tantalum (see 140.9). If the test sample is estimated to contain less than 2 mg of tantalum, add 2 mL of zirconium carrier solution and proceed to 140.12. If the test sample is estimated to contain between 2 mg and 15 mg of tantalum, transfer the sample to a 500-mL plastic volumetric flask, dilute to the mark and mix. Transfer by means of a pipet 50 mL of this solution to an 800-mL plastic beaker, add 2 mL of zirconium solution and dilute to 500 mL. Proceed as described in 140.12.

140.12 Cool the solution in an icebath to approximately 5 °C. Add, with stirring, 15 mL of cold cupferron solution. Filter the precipitate using low-porosity filter paper and a vacuum filtration apparatus. Police the beaker well and rinse with cold HCl (1 + 19). Wash the paper with cold HCl (1 + 19).

140.13 Transfer the paper to a 50-mL platinum crucible. Dry for 1 h under a heat lamp in a hood. Char in a muffle furnace in a hood at 550 °C. Raise the temperature to 650 °C and ignite for 2 h. Cool in a desiccator.

140.14 Add 2.0 g of potassium pyrosulfate and fuse over a burner, swirling the crucible to ensure that all the residue dissolves. Cool, transfer the crucible to a 150-mL beaker, add 50 mL of ammonium oxalate solution and heat to dissolve the fused salt. Rinse crucible into the beaker with ammonium oxalate solution. Cool solution to room temperature.

140.15 Transfer 20.00 mL of pyrogallol solution by means of a pipe into a 100-mL volumetric flask. Add the sample extract and rinse the beaker with ammonium oxalate solution into the flask. Dilute to the mark with ammonium oxalate solution and mix.

140.16 *Reagent Blank Solution*—Treat the blank described in 140.9 exactly the same as described in 140.11 – 140.15.

140.17 *Spectrophotometry*—Wait 15 min for full color development after the final dilution, then measure the absorbance of the reagent blank and test solutions versus water in cell-blank corrected 1-cm cuvettes as directed in 139.4.

141. Calculation

141.1 Subtract the cell-corrected reagent blank (140.16) absorbance from the cell-corrected test solution absorbance and convert this net absorbance to milligrams of tantalum using the calibration curve. Calculate the percentage of tantalum as follows:

$$\text{Tantalum, \%} = A \times B/C \times 10 \quad (25)$$

where:

A = tantalum found in 100 mL of the final test solution, mg,

B = aliquot factor (direct = 1.0; aliquot = 10.0), and

C = sample weight, g.

142. Precision and Bias²⁸

142.1 *Precision*—Six laboratories participated in the testing of this method, providing seven sets of data. The obtained precision is summarized in Table 15.

142.2 *Bias*—The bias of this test method may be judged by comparing accepted reference values with the corresponding arithmetic average obtained by interlaboratory testing, such as the data listed in Table 15.

143. Keywords

143.1 aluminum; chromium; cobalt; cobalt-base alloys; copper; high temperature alloys; iron; manganese; molybdenum; nickel; nickel-base alloys; niobium; silicon; sulfur; tantalum; tin

²⁸ Supporting data have been filed at ASTM International Headquarters and may be obtained by requesting Research Report RR:E01-1014.

ASTM International takes no position respecting the validity of any patent rights asserted in connection with any item mentioned in this standard. Users of this standard are expressly advised that determination of the validity of any such patent rights, and the risk of infringement of such rights, are entirely their own responsibility.

This standard is subject to revision at any time by the responsible technical committee and must be reviewed every five years and if not revised, either reapproved or withdrawn. Your comments are invited either for revision of this standard or for additional standards and should be addressed to ASTM International Headquarters. Your comments will receive careful consideration at a meeting of the responsible technical committee, which you may attend. If you feel that your comments have not received a fair hearing you should make your views known to the ASTM Committee on Standards, at the address shown below.

This standard is copyrighted by ASTM International, 100 Barr Harbor Drive, PO Box C700, West Conshohocken, PA 19428-2959, United States. Individual reprints (single or multiple copies) of this standard may be obtained by contacting ASTM at the above address or at 610-832-9585 (phone), 610-832-9555 (fax), or service@astm.org (e-mail); or through the ASTM website (www.astm.org). Permission rights to photocopy the standard may also be secured from the Copyright Clearance Center, 222 Rosewood Drive, Danvers, MA 01923, Tel: (978) 646-2600; <http://www.copyright.com/>