



Standard Test Method for Determining the Rate of Air Leakage Through Exterior Windows, Curtain Walls, and Doors Under Specified Pressure and Temperature Differences Across the Specimen¹

This standard is issued under the fixed designation E1424; the number immediately following the designation indicates the year of original adoption or, in the case of revision, the year of last revision. A number in parentheses indicates the year of last reapproval. A superscript epsilon (ϵ) indicates an editorial change since the last revision or reapproval.

1. Scope

1.1 This test method provides a standard laboratory procedure for determining the air leakage rates of exterior windows, curtain walls, and doors under specified differential air temperature and pressure conditions across the specimen.

1.2 Specified temperature and pressure conditions are representative of those that may be encountered at the exterior thermal envelope of buildings, excluding the effects of heat buildup due to solar radiation.

1.3 This laboratory procedure is applicable to exterior windows, curtain walls, and doors and is intended to measure only such leakage associated with the assembly and not the installation; however, the test method can be adapted for the latter purpose.

1.4 This is a laboratory procedure for testing at differential temperature conditions. Persons interested in a laboratory test at ambient conditions should reference Test Method E283. Persons interested in a field test on installed windows and doors should reference Test Method E783.

1.5 Persons using this procedure should be knowledgeable in the areas of heat transfer, fluid mechanics, and instrumentation practices, and shall have a general understanding of fenestration products and components.

1.6 The values stated in SI units are to be regarded as standard. The inch-pound units given in parenthesis are provided for information only.

1.7 *This standard does not purport to address all of the safety concerns, if any, associated with its use. It is the responsibility of the user of this standard to establish appropriate safety and health practices and determine the applica-*

bility of regulatory limitations prior to use. For specific hazard statements, see Section 7.

2. Referenced Documents

2.1 ASTM Standards:²

E283 Test Method for Determining Rate of Air Leakage Through Exterior Windows, Curtain Walls, and Doors Under Specified Pressure Differences Across the Specimen

E631 Terminology of Building Constructions

E783 Test Method for Field Measurement of Air Leakage Through Installed Exterior Windows and Doors

3. Terminology

3.1 *Definitions*—Terms used in this test method are defined in Terminology E631.

3.2 *Definitions of Terms Specific to This Standard:*

3.2.1 *air leakage rate (q_A or q_L)*—the air leakage per unit of specimen area (A) or per unit length of operable crack perimeter (L), expressed as $\text{m}^3/\text{s}\cdot\text{m}^2$ ($\text{ft}^3/\text{min}\cdot\text{ft}^2$) or $\text{m}^3/\text{s}\cdot\text{m}$ ($\text{ft}^3/\text{min}\cdot\text{ft}$).

3.2.2 *extraneous air leakage (Q_e)*—the volume of air flowing per unit of time through the test chamber and test apparatus, exclusive of the air flowing through the test specimen, under a test pressure difference and test temperature difference, converted to standard conditions, expressed in m^3/s (ft^3/min).

3.2.2.1 *Discussion*—Extraneous leakage is the sum of all leakage other than that intended to be measured by the test.

3.2.3 *specimen air leakage (Q_s)*—the volume of air flowing per unit of time through the specimen under a test pressure difference and test temperature difference, converted to standard conditions, expressed in m^3/s (ft^3/min).

¹ This test method is under the jurisdiction of ASTM Committee E06 on Performance of Buildings and is the direct responsibility of Subcommittee E06.51 on Performance of Windows, Doors, Skylights and Curtain Walls.

Current edition approved Oct. 1, 2016. Published October 2016. Originally approved in 1991. Last previous edition approved in 2008 as E1424 – 91 (2008). DOI: 10.1520/E1424-91R16.

² For referenced ASTM standards, visit the ASTM website, www.astm.org, or contact ASTM Customer Service at service@astm.org. For *Annual Book of ASTM Standards* volume information, refer to the standard's Document Summary page on the ASTM website.

3.2.4 *specimen area (A)*—the area determined by the overall dimensions of the frame that fits into the rough opening, expressed as m^2 (ft^2).

3.2.5 *test mask assembly*—a wall construction that surrounds and supports the test specimen.

3.2.6 *test pressure differences*—the specified differential static air pressure across the specimen, expressed in PA (lbf/ft^2).

3.2.7 *test temperature difference*—the specified difference in temperature across the test specimen, expressed as a set of room-side and weather-side temperatures, in $^{\circ}C$ ($^{\circ}F$).

3.2.8 *total air flow (Q_t)*—the volume of air flowing per unit of time through the test chamber and test apparatus, inclusive of the air flowing through the test specimen, under a test pressure difference and test temperature difference, converted to standard conditions, expressed in m^3/s (ft^3/min).

3.2.9 *unit length of operable crack perimeter (L)*—the sum of all perimeters of operable ventilators, sash, or doors contained in the test specimen, based on the overall dimensions of such parts, expressed as m (ft). Where two such operable parts meet, the two adjacent lengths of perimeter shall be counted as only one length.

4. Summary of Test Method

4.1 The procedure consists of sealing a specimen into or against a chamber capable of maintaining a specified air temperature differential across the specimen. When the specimen has been conditioned for a specified period of time, air is supplied to, or exhausted from, the chamber at a rate required to maintain the specified test pressure difference across the specimen. The resultant air flow through the specimen is then measured.

5. Significance and Use

5.1 The exterior building envelope and its components (for example, windows and doors) separate the interior conditioned spaces from exterior environmental factors such as heat, cold, rain, wind, noise dust, etc. Building materials and components can expand or contract to varying degrees, depending on seasonal and diurnal exterior ambient air temperatures. Fluctuations in the ambient air temperatures can alter the sealing characteristics of windows, curtain walls, and doors by changing weather seal compression ratios. Thermal expansion or contraction of framing materials coupled with thermal blowing due to temperature gradients through the product, and alterations in the effective leakage areas due to weather seal shrinkage and compression set, can also significantly alter the air leakage rates of these products in field service applications. Air leakage tests performed using Test Method E283 (a laboratory air leakage test performed at ambient temperature conditions) will not account accurately for changes in air leakage rates that may occur from dimensional changes in fenestration systems, materials, and components.

5.2 It is recommended that test specifiers consult the manufacturer for recommended test temperature extremes.

5.3 This procedure provides a means for evaluating air leakage rates of fenestration systems under various temperature

and pressure conditions and air flow directions. It is also applicable for use in evaluating the efficiency of weather sealing products in fenestration systems. All air flow rates are converted to standard conditions to provide a means of comparison between measurements made at different ambient air temperature and pressure conditions.

5.4 Air leakage rates are sometimes used for comparison purposes. Such comparisons may not be valid unless the components being tested and compared are of essentially the same size, configuration, and design.

6. Apparatus

6.1 The description of the apparatus in this section is general. Any suitable arrangement of equipment capable of maintaining the required test tolerances is permitted.

6.1.1 *Test Chamber*—A well sealed box, wall, or other apparatus into or against which the specimen is mounted and secured for testing. An air supply shall be provided to allow a positive or negative pressure differential to be applied across the specimen without significant extraneous losses. The chamber should also be constructed of materials that have good resistance to heat flow. The chamber shall be capable of withstanding the differential test pressures and temperatures that may be encountered in this procedure. At least one static air pressure tap shall be provided on each side of the specimen to measure the test pressure differences. The pressure tap shall be located in an area of the chamber in which pressure readings will not be affected by any supply air or air conditioning fans. The air supply to the chamber shall be located in an area in which it does not directly impinge upon the test specimen. A schematic is given in Fig. 1.

6.1.2 *Supply Air System*—A controllable dry air supply or exhaust system designed to provide conditioned air flow through the test specimen at constant pressure and temperature

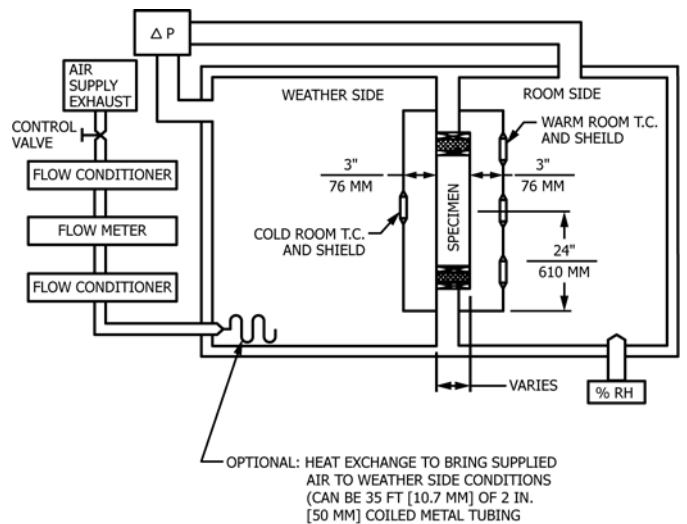

NOTE: AIR FLOW AND METERING SYSTEM MAY BE SET-UP ON THE ROOM SIDE FOR POSITIVE OR NEGATIVE PRESSURE LEAKING MEASUREMENTS.

FIG. 1 Environmental Chamber, Schematic

conditions for sufficient time to obtain required pressure and air flow readings. The system shall be designed to eliminate pressure fluctuations during the air flow measurements. This may be accomplished through the use of a heat exchanger system connected to the air supply port inside of the weathering portion of the test apparatus (see Fig. 1).

6.1.3 *Air Temperature Conditioning System*—A system to maintain weather-side and room-side air test temperatures to within $\pm 1^\circ\text{C}$ (2°F) of setpoint. The system shall consist of heating and refrigeration equipment designed to maintain the required test temperatures for extended periods of time. A means of dehumidification shall be available to control the room-side relative humidity levels to the limits recommended in Table 1.

6.1.4 *Pressure Measuring Apparatus*—A device to measure the differential test pressures to $\pm 2\%$ of setpoint or ± 2.5 Pa (± 0.01 in. of water column), whichever is greater.

6.1.5 *Air Flow Metering System*—A device to measure the air flow into the test chamber or through the test specimen. The air flow measurement error shall not exceed $\pm 5\%$ when the air flow equals or exceeds 9.44×10^{-4} m³/s (2 ft³/min) or $\pm 10\%$ when the air flow is less than 9.44×10^{-4} m³/s (2 ft³/min).

NOTE 1—At lower flows, a greater percentage of errors will be acceptable. Special flow metering techniques are necessary if higher precision is required. The accuracy of the specimen air leakage flow measurement is affected by the accuracy of the flowmeter and the amount of extraneous air leakage (see Annex A1).

6.1.6 *Air Temperature Measuring System*—Temperature sensing devices (TSD) such as thermocouples, RTDS, etc., suspended in air, surrounded by shields to reduce radiative heat transfer effects, as shown in Fig. 2. The thermocouples shall be located at the intersection of the vertical and horizontal centerlines of the test specimen. The air TSD shall be movable to maintain a distance of 76 ± 8 mm (3 ± 0.3 in.) measured perpendicular to the outermost plane of the test specimen. The ambient air and surface temperature measuring and indicating instrumentation shall have resolution of 1°C or 1°F and precision of $\pm 1^\circ\text{C}$ ($\pm 2^\circ\text{F}$).

6.1.7 *Humidity Control System*—Instrumentation to measure and control the room-side humidity. The system shall have resolution to 1% RH and shall have precision to $\pm 3\%$ of setpoint.

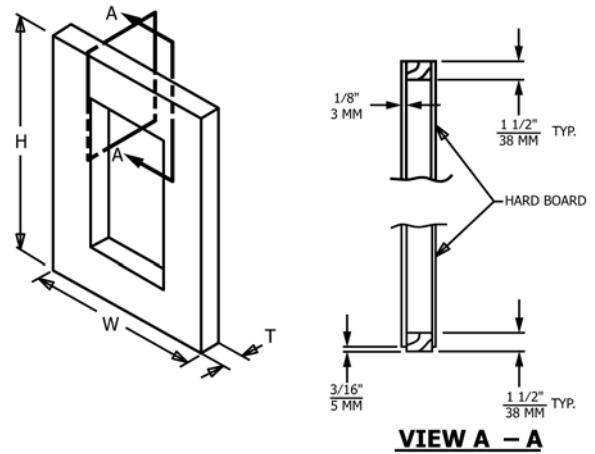

NOTE: MASK WIDTH, HEIGHT AND THICKNESS MAY VARY TO CHAMBER SIZE.

FIG. 2 Test Specimen Mask Detail

7. Hazards

7.1 Glass breakage may occur at the test pressure differences applied in this test. Adequate precautions should be taken to protect personnel.

7.2 The interior walls of the weather-side compartment as well as other surfaces within this compartment may be dangerous to the exposed skin of testing personnel when extreme elevated or depressed test temperature conditions are in effect. Proper care and precautions should be taken to prevent injuries.

8. Test Specimen

8.1 The specimen is the entire assembled unit submitted for testing as described in this section.

8.2 The test specimen for a wall shall be of sufficient size to determine the performance of all typical parts of the wall system. For curtain walls or walls constructed with prefabricated units, the specimen width shall be not less than two typical units plus the connections and supporting elements at both sides, and sufficient to provide full loading on at least one typical vertical joint or framing member, or both. The height shall be not less than the full building story height or the height of the unit, whichever is greater, and shall include at least one full horizontal joint, accommodating vertical expansion, with such joint being at or near the bottom of the specimen, as well as all connections at the top and bottom of the units.

8.2.1 All parts of the wall test specimen shall be full size, using the same materials, details, and methods of construction and anchorage as used on the actual building.

8.2.2 Conditions of structural support shall be simulated as accurately as possible.

8.3 The test specimen for a window, door, or other component shall consist of the entire assembled unit, including frame and anchorage as supplied by the manufacturer for installation in the building. If only one specimen is to be tested, the selection shall be determined by the specifying authority.

NOTE 2—The air leakage rate is likely to be a function of size and geometry of the specimen.

TABLE 1 Recommended Maximum Room-Side Humidity Levels for Glass Specimens—Natural Convection, Indoor Air at 23.3°C (74°F)^A

Outdoor Temperature, °C (°F)	Single Glazing, RH, %	Double Glazing, RH, %
4.4 (40)	39	59
-1.1 (30)	29	50
-6.7 (20)	21	43
-12.2 (10)	15	36
-17.8 (0)	10	30
-23.3 (-10)	7	26
-28.9 (-20)	5	21
-34.4 (-30)	3	17

^A Reference: 1983 ASHRAE EQUIPMENT MANUAL, p. 5.

9. Preparation of Test Specimen

9.1 The location of surface temperature measuring devices shall conform to the configurations shown in Figs. 3-6.

9.2 A test mask assembly shall be provided for the installation of the specimen to the test apparatus. A typical test mask assembly is shown in Fig. 7. The thickness of the test mask assembly shall not be less than the test specimen. Mount the test specimen to the test mask assembly to simulate, as closely as possible, the actual installation conditions anticipated. Seal perimeter joints between the test specimen and the test mask assembly to eliminate extraneous air leakage.

10. Calibration

10.1 Specific procedures for calibration of the total air flow measurement system are being developed in a separate ASTM document; when complete, that document will be referenced. However, all test apparatus shall be calibrated at a minimum of every six months to the tolerances established in Section 6. The procedures for this calibration are, at this time, the responsibility of the testing agency. Calibration should be conducted at or near the environmental conditions (temperature, relative humidity, etc.) under which the tests are to be conducted and to which the test apparatus is to be exposed.

11. Test Conditions

11.1 *General*—Standard test conditions require dry air at:

Pressure—101.3 kpa (29.92 in.Hg)
 Temperature—20.8°C (69.4°F)
 Air density—1.202 kg/m³ (0.075 lbm/ft³)

11.2 *Air Leakage Test Pressures*—Shall be as specified. When unspecified, test pressures shall be 27.0 Pa (0.56 lbf/ft²), 75 Pa (1.57 lbf/ft²), and 300 Pa (6.24 lbf/ft²). The tolerance on all pressure measurements shall be ± 2.5 Pa (± 0.01 in. of water column).

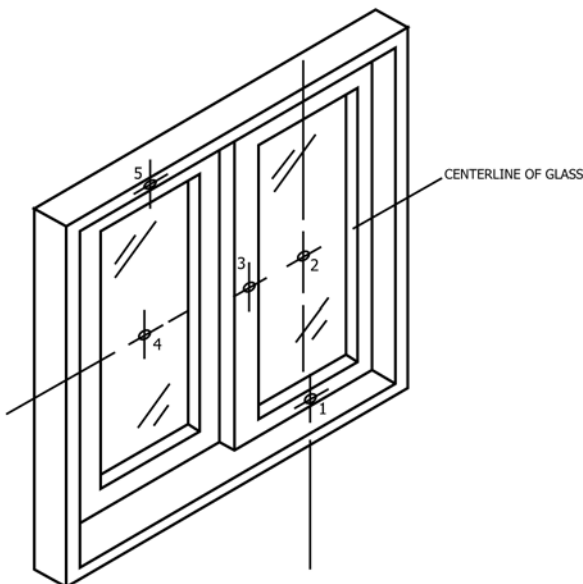
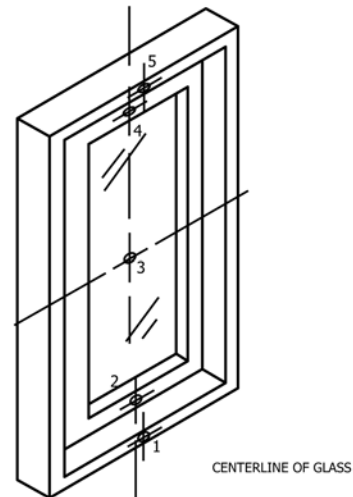

FIG. 3 Thermocouple Location: Horizontal Sliding Window, Casement, or Sliding Glass Door



NOTE 1—Mask width, height, and thickness may vary to chamber size.
 FIG. 4 Thermocouple Location: Casement, Vertical and Horizontal Pivot, Top Hinged, Swinging Door, Fixed, or Single Lite Window

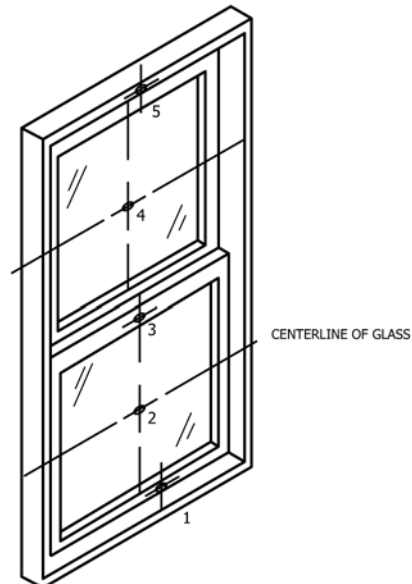

FIG. 5 Thermocouple Location: Single or Double Hung, Awning, Projected, or Vertical Sliding Window

11.3 *Air Flow Direction Through Specimen*—Shall be as specified. When unspecified, air flow shall be infiltration.

NOTE 3—These pressure differences correspond to approximate stagnation pressures at, standard conditions, of wind at velocities of 24 kph (15 mph), 40 kph (25 mph), and 80 kph (50 mph). These wind velocities are provided for informational purposes only and do not take into account gust response, velocity modulation, or turbulence.

11.4 *Test Temperature Differences*—Shall be as specified. When unspecified, test temperature differences in the continental United States shall be a cold temperature mode and a warm temperature mode.

11.4.1 The cold temperature mode shall be $22 \pm 2^\circ\text{C}$ ($72 \pm 3^\circ\text{F}$) room side and $-17 \pm 2^\circ\text{C}$ ($0 \pm 3^\circ\text{F}$) weather side.

11.4.2 The warm temperature mode shall be $22 \pm 2^\circ\text{C}$ ($72 \pm 3^\circ\text{F}$) room side and $43 \pm 2^\circ\text{C}$ ($110 \pm 3^\circ\text{F}$) weather side.

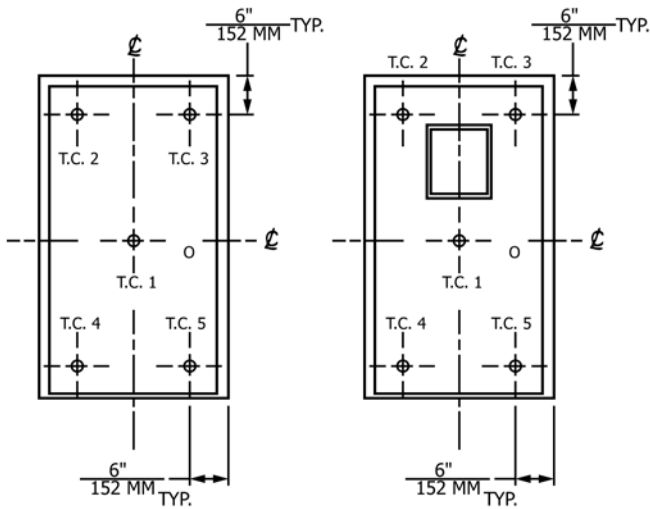

FIG. 6 Thermocouple Location: Entry Door

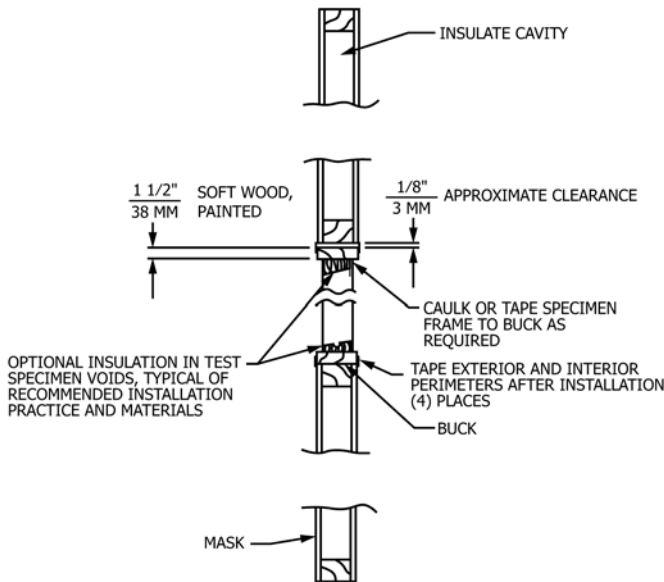

FIG. 7 Window Test Mask Assembly

11.4.3 Humidity levels in the room-side compartment should not exceed the recommended maximum values listed in Table 1 in order to reduce or eliminate the condensation or icing that may occur on the test specimen or the weather sealing perimeters.

NOTE 4—Temperature modes in locations other than the continental United States shall be selected based on local weather data.

NOTE 5—Continental United States cold and warm temperature modes may be beyond the material performance capability of some products designed for a limited geographical marketing area. It is recommended that test specifiers consult the manufacturer for recommended test temperature extremes.

11.5 Air Leakage Rate—The basis for reporting air leakage rates shall be total air leakage, m^3/h (ft^3/min), per unit length of operable crack perimeter, $m^3/h - m$ ($ft^3/min - ft$), and per unit area of outside frame dimension, $m^3/h - m^2$ ($ft^3/min - ft^2$).

12. Procedure

12.1 Remove any sealing material or construction that is not normally a part of the assembly as installed in or on a building. Fit the specimen into or against the chamber opening with the exterior side of the specimen exposed to the weather side of the chamber. The installation should be such that no parts or openings of the specimen are obstructed.

12.2 Without disturbing the seal between the specimen and the mask, adjust all hardware, ventilators, balances, and other components included as an integral part of the specimen so that their operation conforms to specification requirements.

12.3 To ensure proper alignment and weather seal compression, fully open, close, and lock each ventilator, sash, or door five times before testing.

12.4 Preparation of Specimen for Extraneous Air Leakage Measurement:

12.4.1 With the specimen installed and sealed to the mask, seal off the weather-side surface of the specimen with a sheet of 0.1 mm (4 mil nominal) plastic. The plastic sheet should be taped adjacent to the outer perimeter of the specimen, but shall not overlap the joint between the specimen and buck or mask.

12.4.2 When performing exfiltration tests, the specimen room-side surface shall be sealed for extraneous air leakage measurements.

12.5 With the ventilator, sash, or door in the closed and locked position, and with the exterior face of the specimen sealed for extraneous air leakage measurement, attach five thermocouples to the interior face of the specimen as illustrated in Figs. 3-6 for applicable window and door types.

12.6 Condition weather-side and room-side air temperatures and humidities to specified test conditions. Observe specimen surface temperatures to determine when steady-state conditions have been reached.

12.7 Criteria for Determining Steady-State Test Conditions—Steady-state test conditions shall be met when five consecutive observations of each surface thermocouple, made at 10-min intervals, are not trending up or down, and are within $1^\circ C$ ($2^\circ F$) from the highest to the lowest reading at each thermocouple location.

12.8 When the criteria for steady-state has been met, turn off all weather-side and room-side air moving devices (evaporator fans, etc.). Adjust the air flow into or out of the weather-side compartment (room-side compartment for exfiltration tests) to provide the specified test pressure differences across the test specimen.

NOTE 6—The room-side or weather-side compartment may need to be vented to relieve pressure buildup from air leakage between compartments.

12.9 The air leakage characteristics of the specimen may be altered during the pressurization portion of the test as temperature-conditioned air flows through the various leakage paths of the test specimen. During the total air leakage measurement, the specimen shall not be exposed to differential temperature and pressure conditions for periods longer than 5 min. Also, the weather- or room-side air temperature shall not

change by more than 3°C (5°F) from the temperature at the beginning of the test. If either of these test conditions are exceeded, the specimen shall be reconditioned per the requirements of 12.6 – 12.8 before proceeding with the test.

12.10 When the differential test pressure is stabilized, record the air flow into or out of the test chamber, the differential test pressure, the weather-side and room-side ambient air temperatures, and the barometric pressure.

12.11 The first measured air flow into the test chamber with the specimen sealed represents the test chamber and specimen mask leakage and is designated as the extraneous air leakage (Q_e).

12.12 Remove the plastic sheet from the surface of the test specimen. Any ice that may have accumulated on or in the crack perimeter or weep hole areas shall be removed. Exercise care to not disturb any of the surface thermocouples. Ensure that the specimen is closed and locked. Check if the conditions of 12.9 have been exceeded. Repeat 12.8 and 12.10.

12.13 The second measured air flow into the test chamber represents the test specimen and extraneous air leakage. This is the total air leakage and is designated by (Q_t).

12.14 Extraneous and total air leakage measurements may be taken consecutively for more than one pressure differential, provided the requirements of 12.9 are maintained.

13. Calculation

13.1 Express the total air flow, Q_t , and the extraneous leakage, Q_e , in terms of flow at standard conditions, using (Eq 1 and 2).

$$Q_{st} = Q(W/W_s)^{\frac{1}{2}} \quad (1)$$

$$W = 3.485 \times 10^{-3} [B/(T+273)] \quad (2)$$

where:

- Q = airflow at nonstandard conditions,
- Q_{st} = airflow corrected to standard conditions,
- W_s = density of air at reference standard conditions (1.202 kg/m³),
- W = density of air at the flowmeter, kg/m³ (lb/ft³),
- B = barometric pressure at flowmeter, corrected for temperature, Pa, and
- T = temperature of air at flowmeter, °C.

NOTE 7—For IP measurements, $W_s = 0.075$ lb/ft³ and $W = 1.326$ [B/(T+460)], where B is measured in inches, HG, and T is in degrees Fahrenheit.

13.2 Express the air leakage through the test specimen as follows:

$$Q_s = Q_m - Q_e \quad (3)$$

where:

- A_s = air leakage through the test specimen, m³/s (ft³/min).

13.3 Calculate the rate of air leakage for the test specimen according to both of the following methods: (1) Rate of air leakage per unit of length of operable crack perimeter:

$$q_L = Q_s/L, \text{ m}^3/\text{h} - \text{m} \text{ (ft}^3/\text{min} - \text{ft)} \quad (4)$$

and (2) rate of air leakage per unit area:

$$q_A = Q_s/A, \text{ m}^3/\text{h} - \text{m}^2 \text{ (ft}^3/\text{min} - \text{ft}^2) \quad (5)$$

14. Report

14.1 Report the following information:

14.1.1 *General*—Testing agency, date and time of test, and date of report.

14.1.2 *Sample Description*—Manufacturer, model, operation type, materials, and other pertinent information; description of the locking and operating mechanisms if applicable; glass thickness and type and method of glazing; weather seal dimensions, type, and material; and crack perimeter and specimen area.

14.1.3 *Drawings of Specimen*—Detailed drawings of the specimen showing dimensioned section profiles, sash or door dimensions and arrangement, framing location, panel arrangement, installation and spacing or anchorage, weatherstripping, locking arrangement, hardware, sealants, glazing details, and any other pertinent construction details. Note any modifications made on the specimen to obtain the reported test values.

14.1.4 *Test Parameters*—List or describe the specified test pressure and temperature difference(s), whether the tests were conducted for infiltration or exfiltration, and whether a positive or negative test pressure was used.

14.1.5 *Ambient Test Conditions*—List the ambient air temperature, relative humidity, and barometric pressure as measured and recorded during the test.

14.1.6 *Air Leakage*—A statement or tabulation of the pressure and temperature differentials exerted across the specimen during the test, the corresponding specimen air leakage (Q_s), and the two air leakage rates (q_L and q_A).

14.1.7 *Compliance Statement*—A statement that the tests were conducted in accordance with this test method, or a complete description of any deviation from this test method. When the tests are conducted to check for conformity of the specimen to a particular performance specification, the specification shall be identified.

14.2 If several identical specimens are tested, the results for each specimen shall be reported, each specimen being properly identified, particularly with respect to distinguishing features or differing adjustment. A separate drawing for each specimen shall not be required if all differences between the specimens are noted on the drawings provided.

15. Precision and Bias

15.1 The precision and bias of this test method will be determined by a round robin study among laboratories and manufacturers.

16. Keywords

16.1 air leakage; curtain walls; differential temperature; doors; energy analysis; fenestration; laboratory method; static pressure chamber; testing; test method; windows

ANNEX
(Mandatory Information)
A1. ERRORS IN WINDOW AIR LEAKAGE MEASUREMENT

A1.1 In the apparatus using a supply air system,

$$Q_s = Q_{ts} - Q_{es} \quad (\text{A1.1})$$

where:

Q_s = air flow through specimen,

Q_{ts} = total air flow, and

Q_{es} = extraneous air flow.

NOTE A1.1—All of the above have been converted to standard conditions.

A1.1.1 The extraneous air leakage, Q_{es} , represents all of the air leakage leaving the chamber that does not pass through the specimen proper. This includes leakage passing through the chamber walls and around the specimen mounting. When the mounting panel is used, leakage between the chamber and the panel contributes to extraneous leakage. The extraneous leakage flow is a function of the pressure difference between the chamber and the room, which is also the test specimen difference.

A1.2 The total error in the specimen flow determination (neglecting errors in the air density determination) is as follows:

$$\Delta Q_s / Q_s = [\Delta Q_{ts} / (Q_{ts} - Q_{es})] \pm [\Delta Q_{es} / (Q_{ts} - Q_{es})] \quad (\text{A1.2})$$

ASTM International takes no position respecting the validity of any patent rights asserted in connection with any item mentioned in this standard. Users of this standard are expressly advised that determination of the validity of any such patent rights, and the risk of infringement of such rights, are entirely their own responsibility.

This standard is subject to revision at any time by the responsible technical committee and must be reviewed every five years and if not revised, either reapproved or withdrawn. Your comments are invited either for revision of this standard or for additional standards and should be addressed to ASTM International Headquarters. Your comments will receive careful consideration at a meeting of the responsible technical committee, which you may attend. If you feel that your comments have not received a fair hearing you should make your views known to the ASTM Committee on Standards, at the address shown below.

This standard is copyrighted by ASTM International, 100 Barr Harbor Drive, PO Box C700, West Conshohocken, PA 19428-2959, United States. Individual reprints (single or multiple copies) of this standard may be obtained by contacting ASTM at the above address or at 610-832-9585 (phone), 610-832-9555 (fax), or service@astm.org (e-mail); or through the ASTM website (www.astm.org). Permission rights to photocopy the standard may also be secured from the Copyright Clearance Center, 222 Rosewood Drive, Danvers, MA 01923, Tel: (978) 646-2600; http://www.copyright.com/

A1.2.1 According to 6.1.5, the air flow through the test specimen is to be determined with an error no greater than

$$\Delta Q_s / Q_s = \pm 5 \% \quad (\text{A1.3})$$

If the extraneous leakage is accurate to

$$\Delta Q_{es} / Q_{es} = \pm 10 \% \quad (\text{A1.4})$$

and Q_{es} is 10 % of Q_s , then the contribution of the extraneous leakage to the overall error in (Eq A1.2) is ± 1 %.

NOTE A1.2—The error attributed to the extraneous leakage determination is a function not only of the accuracy of the flow meter used in the determination, but also of the constancy of the leakage from the time of determination to the time of test. The error contributed by the flow meter to the total error is then limited to 4 %, but because $Q_{ts} = Q_s + Q_{es} = 1.10 Q_s$, the accuracy required of the flowmeter is

$$\Delta Q_{ts} / Q_{ts} = 4 \% / 1.1 = 3.6 \% \quad (\text{A1.5})$$

A1.2.2 It is seen that the major factor affecting the accuracy required of the flow meter is the proportion of Q_{es} to Q_s . If $\Delta Q_{es} / Q_{es}$ remains at ± 10 % but Q_{ts} is 50 % of Q_s , the error contributed by the extraneous leakage becomes 5 %, and no error can be tolerated in the flow meter if the conditions of 6.1.5 are to be met. With Q_{es} in excess of 50 %, it is impossible to achieve the required overall limit of error. Likewise, if the extraneous leakage is eliminated, the flow meter error can be as great as 5 %.