



# Standard Specification for Illuminators Used for Viewing Industrial Radiographs<sup>1</sup>

This standard is issued under the fixed designation E1390; the number immediately following the designation indicates the year of original adoption or, in the case of revision, the year of last revision. A number in parentheses indicates the year of last reapproval. A superscript epsilon ( $\epsilon$ ) indicates an editorial change since the last revision or reapproval.

## 1. Scope

1.1 The function of the illuminator is to provide sufficient illumination and viewing capabilities for the purpose of identification and interpretation of radiographic images. This specification provides the recommended minimum requirements for Industrial Radiographic Illuminators used for viewing industrial radiographic films using transmitted light sources.

1.2 The illuminator has to ensure the same safety for personnel, or users of any electric apparatus, as specified by electrical standards applicable in the country in which the illuminator is used.

1.3 *This standard does not purport to address all of the safety concerns, if any, associated with its use. It is the responsibility of the user of this standard to establish appropriate safety and health practices and determine the applicability of regulatory limitations prior to use.*

1.4 Values stated in SI units are to be regarded as the standard. The values given in parentheses are provided for information only.

## 2. Referenced Documents

2.1 *ASTM Standards:*<sup>2</sup>

E1316 Terminology for Nondestructive Examinations

## 3. Terminology

3.1 *Definitions:*

3.1.1 *diffusing screen*—the screen that scatters the light such that the light appears the same brightness from any viewing angle.

3.1.2 *viewing screen*—the port through which the light is projected.

3.2 For additional definitions of terms used in this specification, see Terminology E1316.

<sup>1</sup> This specification is under the jurisdiction of ASTM Committee E07 on Nondestructive Testing and is the direct responsibility of Subcommittee E07.01 on Radiology (X and Gamma) Method.

Current edition approved Dec. 1, 2016. Published December 2016. Originally approved in 1990. Last previous edition approved in 2012 as E1390 - 12. DOI: 10.1520/E1390-12R16.

<sup>2</sup> For referenced ASTM standards, visit the ASTM website, www.astm.org, or contact ASTM Customer Service at service@astm.org. For *Annual Book of ASTM Standards* volume information, refer to the standard's Document Summary page on the ASTM website.

## 4. Ordering Information

4.1 This specification is intended to be used by the manufacturers and purchasers of radiographic illuminators. Requirements, if imposed on manufacturers, should be established by contractual agreement or appropriate purchase document.

## 5. Materials and Manufacture

5.1 *General*—The illuminator shall consist of a housing with one or more of the sides containing a viewing screen illuminated from the inside of the housing. The viewing screen may also be the diffusing screen. There shall be thermal protection to prevent overheating, and subsequent damage to the radiographs placed on the viewing screen. The housing or system may or may not require ventilation. A rheostat or suitable electrical circuit shall be provided to vary the light intensity.

## 6. Physical Properties

6.1 *General*—The illuminator shall be manufactured of materials deemed suitable to withstand the environmental conditions encountered under normal operating conditions.

6.2 *Viewing Screen*—The viewing screen shall be easy to clean and made of material which is resistant to scratches. The size of the screen shall allow the user to view the radiograph without excessive glare. If the illuminator is to be used for viewing radiographs of various sizes, masks of various sizes and configurations should be provided. Alternately, an adjustable aperture may be used.

6.3 *Color of Light*—The color of the light used to illuminate the radiograph shall be white, that is, color temperature between 5000 and 6250°K. However, illuminators using non-white or “colored” light may be used if they have been recommended by the film manufacturers.

6.4 *Diffusing Screen*—If the illuminator has a diffusing screen, the light shall be sufficiently divergent in accordance with 7.2.

6.5 *Housing*—The external housing shall be constructed in such a manner that no disturbing light hinders the viewing of the radiographs.

6.6 *Anti-Glare Device*—The illuminator shall be fitted with an anti-glare switch or device that minimizes the probability of

the operator being subjected to excessive glare when the radiograph is removed. This switch or device may be manual or automatic.

6.7 *Illuminators Used for Viewing “Wet” Radiographs*—Illuminators manufactured for use in viewing “wet” radiographs shall be manufactured to prevent the penetration of liquid into internal electrical components in such a manner that safe operation of the unit would be compromised.

**7. Performance Requirements**

7.1 *Maximum Luminance output*—The luminance of the transmitted light shall not be less than 30 candelas per square metre for film densities equal to or less than 2.5 optical density and not less than 10 candelas per square metre for film densities greater than 2.5 optical density.

7.2 *Divergence and Diffusion of Light*—If the illuminator has a diffusing screen, the light shall be sufficiently divergent so that both eyes of the observer receive rays from all parts of the screen. The divergence factor shall exceed 0.7.

7.3 The viewing screen shall be uniformly illuminated with the uniformity factor  $\delta$  being higher than 0.5.

7.4 Appropriate precautions shall be taken by the manufacturer to ensure that temperature of the housing does not exceed 60°C (140°F) at the usual contact surfaces after one hour of operation at a 50 % duty cycle.

7.5 A radiograph having a density of 2.0 optical density when placed onto the illuminator viewing surface shall not warp or curl after one minute of continuous viewing time and one hour of operation of the illuminator at a 50 % duty cycle.

**8. Scope**

8.1 The following tests shall be utilized to verify the performance requirements specified in 7.1 through 7.3 of this specification.

8.1.1 Maximum illuminator luminance shall be determined using a calibrated photometer placed at the center of the viewing surface, and shall be measured in accordance with the directions specified by the photometer’s manufacturer.

8.1.2 Maximum illuminator luminance measurements are to take place in a room with less than 20 lux (approximately 2 footcandles) of background light. Light escaping from the illuminator even when the viewing screen is completely masked shall not affect the measurements.

8.2 *Divergence and Diffusion of Light*—If the illuminator has a diffusing screen, the light shall be sufficiently divergent so that both eyes of the observer receive rays from all parts of the screen. The divergence factor shall exceed 0.7.

8.2.1 The luminance shall be measured on a semi-circle, the center of which is center of the screen.

8.2.2 The diameter of the circle is approximately the same as the maximum dimension of the screen (the diagonal). The radius of this semi-circle should be at least 25 cm (10 in.).

8.2.3 The luminance is measured with the aid of an appropriate luminance photometer whose sensitive surface is tangent to the curve of the circle (see Fig. 1). These measurements shall be made at angles of 5° ( $L_5$ ), 20° ( $L_{20}$ ), and 45° ( $L_{45}$ ) relative

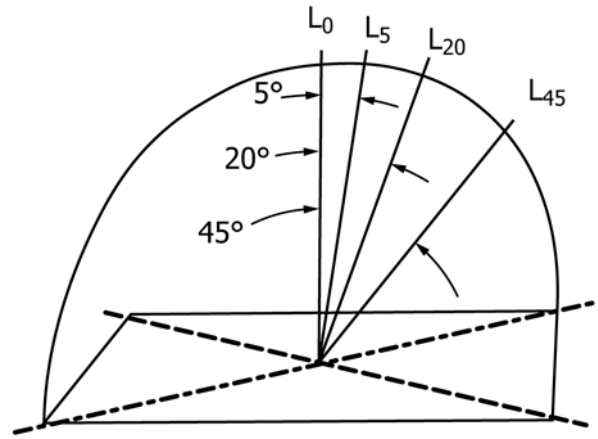

FIG. 1 Measurement Angles of Diversion and Dispersion of Light

to the normal ( $L_0$ ) to the diffusing screen. The divergence factor,  $\sigma'$ , shall be calculated according to the following equation:

$$\sigma' = \frac{L_{45} + L_{20}}{2 L_5}$$

8.3 The viewing screen shall be uniformly illuminated with the uniformity factor  $\delta$  being higher than 0.5, and calculated in the following manner:

8.3.1 The measurements shall be made with the aid of an illumination photometer or other suitable instrument.

8.3.2 If the screen is rectangular, it shall be divided into squares, each side of the squares measuring 3.5 cm, the luminance of each being measured separately. If the screen is circular, the same basic procedure shall be followed. In both cases, the network of the squares shall be so arranged that the middle square is centered in the middle of the screen.

8.3.3 The average of the four highest and the average of the four lowest results shall be found, which give the average arithmetical values of the luminance  $L_{max}$  and  $L_{min}$ . The uniformity factor  $g$  shall then be calculated according to the formula:

$$\delta = \frac{L_{min}}{L_{max}}$$

**9. Certification**

9.1 The manufacturer is responsible for certifying that the illuminator conforms to the requirements of this specification prior to shipping to customer.

9.2 At the request of the customer, the manufacturer of the illuminator shall provide a written statement indicating conformance to the requirements of this specification and test results if requested.

**10. Product Marking**

10.1 Each illuminator will have the following information permanently affixed by the manufacturer:

10.1.1 Nominal operating voltage or permissible voltage range.

10.1.2 Nominal line frequency or permissible frequency range.

10.1.3 Whether direct, alternating current, or both may be used.

10.1.4 Whether designed for use with “wet” film viewing.

10.1.5 Nominal power consumption.

10.1.6 Maximum brightness in candelas per square metre as calculated during factory acceptance tests.

10.1.7 Lamp type.

## **11. Packaging and Package Marking**

11.1 Each illuminator will be provided with operating instructions that address the following:

11.1.1 Safety precautions to be expected during the normal operating conditions.

11.1.2 Operating conditions.

11.1.3 Instructions for mounting and replacements of lamps and screens.

11.1.4 Care and recommended maintenance procedures.

11.1.5 Replacement lamp and screen identification and supplier contact information.

## **12. Quality Assurance**

12.1 The manufacturer is responsible for testing and certifying that the illuminator conforms to the requirements of this specification prior to shipping to customer.

## **13. Keywords**

13.1 illuminator; luminance; radiograph

*ASTM International takes no position respecting the validity of any patent rights asserted in connection with any item mentioned in this standard. Users of this standard are expressly advised that determination of the validity of any such patent rights, and the risk of infringement of such rights, are entirely their own responsibility.*

*This standard is subject to revision at any time by the responsible technical committee and must be reviewed every five years and if not revised, either reapproved or withdrawn. Your comments are invited either for revision of this standard or for additional standards and should be addressed to ASTM International Headquarters. Your comments will receive careful consideration at a meeting of the responsible technical committee, which you may attend. If you feel that your comments have not received a fair hearing you should make your views known to the ASTM Committee on Standards, at the address shown below.*

*This standard is copyrighted by ASTM International, 100 Barr Harbor Drive, PO Box C700, West Conshohocken, PA 19428-2959, United States. Individual reprints (single or multiple copies) of this standard may be obtained by contacting ASTM at the above address or at 610-832-9585 (phone), 610-832-9555 (fax), or service@astm.org (e-mail); or through the ASTM website (www.astm.org). Permission rights to photocopy the standard may also be secured from the Copyright Clearance Center, 222 Rosewood Drive, Danvers, MA 01923, Tel: (978) 646-2600; <http://www.copyright.com/>*