



# Standard Practice for Minimizing Dosimetry Errors in Radiation Hardness Testing of Silicon Electronic Devices Using Co-60 Sources<sup>1</sup>

This standard is issued under the fixed designation E1249; the number immediately following the designation indicates the year of original adoption or, in the case of revision, the year of last revision. A number in parentheses indicates the year of last reapproval. A superscript epsilon ( $\epsilon$ ) indicates an editorial change since the last revision or reapproval.

*This standard has been approved for use by agencies of the U.S. Department of Defense.*

## 1. Scope

1.1 This practice covers recommended procedures for the use of dosimeters, such as thermoluminescent dosimeters (TLD's), to determine the absorbed dose in a region of interest within an electronic device irradiated using a Co-60 source. Co-60 sources are commonly used for the absorbed dose testing of silicon electronic devices.

NOTE 1—This absorbed-dose testing is sometimes called “total dose testing” to distinguish it from “dose rate testing.”

NOTE 2—The effects of ionizing radiation on some types of electronic devices may depend on both the absorbed dose and the absorbed dose rate; that is, the effects may be different if the device is irradiated to the same absorbed-dose level at different absorbed-dose rates. Absorbed-dose rate effects are not covered in this practice but should be considered in radiation hardness testing.

1.2 The principal potential error for the measurement of absorbed dose in electronic devices arises from non-equilibrium energy deposition effects in the vicinity of material interfaces.

1.3 Information is given about absorbed-dose enhancement effects in the vicinity of material interfaces. The sensitivity of such effects to low energy components in the Co-60 photon energy spectrum is emphasized.

1.4 A brief description is given of typical Co-60 sources with special emphasis on the presence of low energy components in the photon energy spectrum output from such sources.

1.5 Procedures are given for minimizing the low energy components of the photon energy spectrum from Co-60 sources, using filtration. The use of a filter box to achieve such filtration is recommended.

1.6 Information is given on absorbed-dose enhancement effects that are dependent on the device orientation with respect to the Co-60 source.

1.7 The use of spectrum filtration and appropriate device orientation provides a radiation environment whereby the absorbed dose in the sensitive region of an electronic device can be calculated within defined error limits without detailed knowledge of either the device structure or of the photon energy spectrum of the source, and hence, without knowing the details of the absorbed-dose enhancement effects.

1.8 The recommendations of this practice are primarily applicable to piece-part testing of electronic devices. Electronic circuit board and electronic system testing may introduce problems that are not adequately treated by the methods recommended here.

1.9 *This standard does not purport to address all of the safety problems, if any, associated with its use. It is the responsibility of the user of this standard to establish appropriate safety and health practices and determine the applicability of regulatory limitations prior to use.*

## 2. Referenced Documents

### 2.1 ASTM Standards:<sup>2</sup>

- [E170 Terminology Relating to Radiation Measurements and Dosimetry](#)
- [E666 Practice for Calculating Absorbed Dose From Gamma or X Radiation](#)
- [E668 Practice for Application of Thermoluminescence-Dosimetry \(TLD\) Systems for Determining Absorbed Dose in Radiation-Hardness Testing of Electronic Devices](#)
- [E1250 Test Method for Application of Ionization Chambers to Assess the Low Energy Gamma Component of](#)

<sup>1</sup> This practice is under the jurisdiction of ASTM Committee E10 on Nuclear Technology and Applications and is the direct responsibility of Subcommittee E10.07 on Radiation Dosimetry for Radiation Effects on Materials and Devices.

Current edition approved June 1, 2015. Published July 2015. Originally approved in 1988. Last previous edition approved in 2010 as E1249-10. DOI: 10.1520/E1249-15.

<sup>2</sup> For referenced ASTM standards, visit the ASTM website, [www.astm.org](http://www.astm.org), or contact ASTM Customer Service at [service@astm.org](mailto:service@astm.org). For *Annual Book of ASTM Standards* volume information, refer to the standard's Document Summary page on the ASTM website.

## Cobalt-60 Irradiators Used in Radiation-Hardness Testing of Silicon Electronic Devices

2.2 *International Commission on Radiation Units and Measurements Reports:*

ICRU Report 14 Radiation Dosimetry: X-Rays and Gamma Rays With Maximum Photon Energies Between 0.6 and 50 MeV<sup>3</sup>

ICRU Report 18 Specification of High Activity Gamma-Ray Sources<sup>3</sup>

### 3. Terminology

3.1 *absorber*—material that reduces the photon fluence rate from a Co-60 source by any interaction mechanism.

3.2 *absorbed-dose enhancement*—increase (or decrease) in the absorbed dose (as compared to the equilibrium absorbed dose) at a point in a material of interest. This can be expected to occur near an interface with a material of higher or lower atomic number.

3.3 *absorbed-dose enhancement factor*—ratio of the absorbed dose at a point in a material of interest to the equilibrium absorbed dose in that same material.

3.4 *average absorbed dose*—mass weighted mean of the absorbed dose over a region of interest.

3.5 *average absorbed-dose enhancement factor*—ratio of the average absorbed dose in a region of interest to the equilibrium absorbed dose (1).<sup>4</sup>

NOTE 3—For a description of the necessary conditions for measuring equilibrium absorbed dose, see 6.3.1 and the term charged particle equilibrium in Terminology E170, which provides definitions and descriptions of other applicable terms of this practice.

3.6 *beam trap*—absorber that is designed to remove the beam that has been transmitted through the device under test. Its purpose is to eliminate the scattering of the transmitted beam back into the device under test.

3.7 *clean spectrum*—one that is relatively free of low energy components in the photon energy spectrum. For example, for a Co-60 source an ideally clean spectrum would contain only the primary 1.17 and 1.33 MeV photons of Co-60 decay.

3.8 *equilibrium absorbed dose*—absorbed dose at some incremental volume within the material in which the condition of charged particle equilibrium (the energies, number, and direction of charged particles induced by the radiation are constant throughout the volume) exists (see Terminology E170).

NOTE 4—For practical purposes the equilibrium absorbed dose is the absorbed dose value that exists in a material at a distance from any interface with another material, greater than the range of the maximum energy secondary electrons generated by the incident photons.

3.9 *filter box*—container, made of one or more layers of different materials, surrounding a device under test or a

dosimeter, or both, for the purpose of minimizing low energy components of the incident photon energy spectrum.

3.10 *spectrum filter*—material layer intercepting photons on their path between the Co-60 source and the device under test. The purpose of the filter is to reduce low energy components of the photon energy spectrum.

3.11 *spectrum hardening*—process by which the fraction of low energy components of the photon energy spectrum is reduced.

3.12 *spectrum softening*—process by which the fraction of low energy components of the photon energy spectrum is increased.

### 4. Significance and Use

4.1 *Division of the Co-60 Hardness Testing into Five Parts:*

4.1.1 The equilibrium absorbed dose shall be measured with a dosimeter, such as a TLD, located adjacent to the device under test. Alternatively, a dosimeter may be irradiated in the position of the device before or after irradiation of the device.

4.1.2 This absorbed dose measured by the dosimeter shall be converted to the equilibrium absorbed dose in the material of interest within the critical region within the device under test, for example the SiO<sub>2</sub> gate oxide of an MOS device.

4.1.3 A correction for absorbed-dose enhancement effects shall be considered. This correction is dependent upon the photon energy that strikes the device under test.

4.1.4 A correlation should be made between the absorbed dose in the critical region (for example, the gate oxide mentioned in 4.1.2) and some electrically important effect (such as charge trapped at the Si/SiO<sub>2</sub> interface as manifested by a shift in threshold voltage).

4.1.5 An extrapolation should then be made from the results of the test to the results that would be expected for the device under test under actual operating conditions.

NOTE 5—The parts of a test discussed in 4.1.2 and 4.1.3 are the subject of this practice. The subject of 4.1.1 is covered and referenced in other standards such as Practice E668 and ICRU Report 14. The parts of a test discussed in 4.1.4 and 4.1.5 are outside the scope of this practice.

4.2 *Low-Energy Components in the Spectrum*—Some of the primary Co-60 gamma rays (1.17 and 1.33 MeV) produce lower energy photons by Compton scattering within the Co-60 source structure, within materials that lie between the source and the device under test, and within materials that lie beyond the device but contribute to backscattering. As a result of the complexity of these effects, the photon energy spectrum striking the device usually is not well known. This point is further discussed in Section 5 and Appendix X1. The presence of low-energy photons in the incident spectrum can result in dosimetry errors. This practice defines test procedures that should minimize dosimetry errors without the need to know the spectrum. These recommended procedures are discussed in 4.5, 4.6, Section 7, and Appendix X5.

4.3 *Conversion to Equilibrium Absorbed Dose in the Device Material*—The conversion from the measured absorbed dose in the material of the dosimeter (such as the CaF<sub>2</sub> of a TLD) to the equivalent absorbed dose in the material of interest (such as the SiO<sub>2</sub> of the gate oxide of a device) is dependent on the incident

<sup>3</sup> Available from International Commission on Radiation Units, 7910 Woodmont Ave., Washington, DC 20014.

<sup>4</sup> The boldface numbers in parentheses refer to the list of references appended to this practice.

photon energy spectrum. However, if the simplifying assumption is made that all incident photons have the energies of the primary Co-60 gamma rays, then the conversion from absorbed dose in the dosimeter to that in the device under test can be made using tabulated values for the energy absorption coefficients for the dosimeter and device materials. Where this simplification is appropriate, the error incurred by its use to determine equilibrium absorbed dose is usually less than 5 % (see 6.3).

**4.4 Absorbed-Dose Enhancement Effects**— If a higher atomic number material lies adjacent to a lower atomic number material, the energy deposition in the region adjacent to the interface is a complex function of the incident photon energy spectrum, the material composition, and the spatial arrangement of the source and absorbers. The absorbed dose near such an interface cannot be adequately determined using the procedure outlined in 4.3. Errors incurred by failure to account for these effects may, in unusual cases, exceed a factor of five. Because microelectronic devices characteristically contain layers of dissimilar materials with thicknesses of tens of nanometres, absorbed-dose enhancement effects are a characteristic problem for irradiation of such devices (see 6.1 and Appendix X2).

**4.5 Minimizing Absorbed-Dose Enhancement Effects**— Under some circumstances, absorbed-dose enhancement effects can be minimized by hardening the spectrum. Hardening is accomplished by the use of high atomic number absorbers to remove low energy components of the spectrum, and by minimizing the amount and proximity of low atomic number material to reduce softening of the spectrum by Compton scattering (see Sections 6 and 7).

**4.6 Limits of the Dosimetry Errors**— To correct for absorbed-dose enhancement by calculational methods would require a knowledge of the incident photon energy spectrum and the detailed structure of the device under test. To measure absorbed-dose enhancement would require methods for simulating the irradiation conditions and device geometry. Such corrections are impractical for routine hardness testing. However, if the methods specified in Section 7 are used to minimize absorbed-dose enhancement effects, errors due to the absence of a correction for these effects can be kept within bounds that may be acceptable for many users. An estimate of these error bounds for representative cases is given in Section 7 and Appendix X5.

**4.7 Application to Non-Silicon Devices**— The material of this practice is primarily directed toward silicon based solid state electronic devices. The application of the material and recommendations presented here should be applied to gallium arsenide and other types of devices only with caution.

## 5. Description of Co-60 Sources

5.1 Cobalt-60 principally decays by emitting gamma rays of 1.17 and 1.33 MeV. In most sources, Co-60 is doubly encapsulated in stainless steel; the sources are supported on structures, usually of aluminum alloys or stainless steel. For some sources, the output is collimated using iron, lead, or other high-density metals or combinations of these absorbers.

Finally, shielding materials of tungsten, lead, concrete, or water are often present. Therefore, a significant fraction of the photons incident on the device under test are the result of Compton scattering that produces low energy components in the source output photon energy spectrum (see ICRU Report 18 for additional discussion of gamma-ray sources).

NOTE 6—As an example, the energy spectrum from even a relatively clean Co-60 source has about 35 % of its total number of photons with energies of less than 1 MeV (see Ref (2) and Appendix X1).

5.2 Even for a given source, a considerable variability exists in the output energy spectrum depending on the geometry and position of irradiation. The spectrum at any position is affected by scattering from walls, floor, and ceiling and by scattering from material located nearby.

NOTE 7—A qualitative estimate of the spectrum hardness for a given source can be obtained using Method E1250.

5.3 The following Co-60 source types are described briefly and listed in the order of decreasing relative spectrum hardness under the most favorable conditions of irradiation.

NOTE 8—Diagrams of typical sources, a nominal photon energy spectrum for each, and references are given in Appendix X1.

5.3.1 A *teletherapy source* is a completely shielded source from which the photon output is confined to a beam that is usually collimated. The source output is typically directed into a shielded room, but a shielded container, or box, is used in some cases.

5.3.2 A *room source* is a source contained in a shielded well from which it is moved into a shielded room by remote control. Its position in the room relative to walls, floor, and ceiling and other scattering material determines the relative hardness of its effective photon energy spectrum. As a result, the photon energy spectrum obtained in a room source can be relatively hard or relatively soft as compared with other Co-60 sources.

5.3.3 A *water well source* is a completely shielded source at a certain depth in a pool of water to which access for irradiations is by means of a water-tight container, or can. A cylindrical array of sealed stainless-steel pencils containing Co-60 pellets is the normal source geometry. The photon energy spectrum depends on whether irradiations are made inside or outside the array, with the former arrangement having the hardest spectrum.

5.3.4 A *shielded-cavity irradiator* is a self-contained shielded source that is usually contained in steel and lead surrounding a cavity in which irradiations can be carried out. Self-absorption and scattering affect the photon energy spectrum.

## 6. Factors Affecting Absorbed Dose Measurement

6.1 *Absorbed-dose Enhancement Near Material Interfaces:*

6.1.1 For illustration, most semiconductor devices can be represented as one-dimensional planar layers of active and structural materials. The energy deposition by secondary electrons produced by photons near the interface between layers depends, in a complex way, on (a) the effective atomic number of the layers, (b) the photon energy, (c) the photon direction, and (d) the layer thickness.

6.1.2 An illustration of the effect of photon energy and direction is shown in Fig. 1 (3). It shows the absorbed dose as a function of distance from an interface between high- and low-atomic-number materials.

6.1.2.1 The effect at the interface at low-photon energies (about 10–200 keV) is strongly dependent on energy and material atomic number and not very dependent on the direction of incident photons. The effect extends over a region of the order of hundreds of nanometers from the interface.

6.1.2.2 The effect at higher photon energies (about 1 MeV) is not strongly dependent on photon energy or the atomic numbers of the materials; however, it is strongly dependent on the direction of the incident photons. At such energies, the effect extends over a region of hundreds of micrometers from the interface.

6.1.3 Absorbed-dose enhancement effects are caused mainly by nonequilibrium electron transport (see Appendix X2).

6.2 Co-60 Photon Energy Spectrum Hardening and Softening:

6.2.1 The Co-60 photons will pass through, or be scattered from, other materials on their path from the source location to the region of interest within the device under test.

6.2.2 Such intervening materials will add low energy photons to the Co-60 spectrum through Compton scattering and will remove low energy photons from the spectrum through photoelectric absorption.

6.2.3 High atomic number materials (such as Pb) tend to harden the spectrum. Low atomic number materials (such as Al or H<sub>2</sub>O) tend to soften the spectrum.

6.2.4 For more details of the interaction of the test setup with the Co-60 photon beam, see Appendix X3.

6.3 Conversion of Dosimeter Absorbed Dose to Device Absorbed Dose:

6.3.1 Conversion from the measured absorbed dose in the dosimeter (such as a TLD) to the equilibrium absorbed dose in the device material of interest can be performed using the following equation:

$$D_a = D_b \frac{(\mu_{en}/\rho)_a}{(\mu_{en}/\rho)_b} \quad (1)$$

where:

- $D_a$  = equilibrium absorbed dose in the device material,
- $D_b$  = equilibrium absorbed dose in the dosimeter,
- $(\mu_{en}/\rho)_a$  = mass energy absorption coefficient for the device material, and
- $(\mu_{en}/\rho)_b$  = mass energy absorption coefficient for the dosimeter.

6.3.2 Since the mass energy absorption coefficients appear in the equation as a ratio, the values of those coefficients shall be, therefore, in the same units. Values of mass energy absorption coefficients for typical materials encountered are given in Appendix X4. The unit of the absorbed dose in the device material will be consistent with the unit of absorbed dose measured by the dosimeter. (For a discussion of units, see Terminology E170).

6.3.3 An example of a dosimeter would be a CaF<sub>2</sub> TLD. An example of a device material of interest would be the SiO<sub>2</sub> of the gate oxide of a device. For further discussion and other examples of the application of this calculation, see Practices E666 and E668.

6.3.4 The use of Eq 1 is strictly applicable only if the following assumptions and restrictions are met:

6.3.4.1 Both the dosimeter and device are sufficiently thin that the incident photons are not significantly attenuated.

6.3.4.2 Charged particle equilibrium is established in the sensitive volume of the device and in the dosimeter.

6.3.4.3 The ratio of mass energy absorption coefficients is constant over the photon energy range.

6.3.4.4 The incident photon energy spectrum is the same for the dosimeter and the device material of interest.

6.3.4.5 Absorbed-dose enhancement effects are negligible.

6.3.5 The use of Eq 1, without a correction for absorbed-dose enhancement effects, gives good accuracy when the volume of interest is sufficiently far from interfaces, or where interface regions form a negligible fraction of the volume of interest. The thickness of the region where absorbed-dose enhancement effects are important is dependent on the range of Compton electrons and photoelectrons produced in the energy deposition processes. Additional detail on the processes can be found in 6.1 and Appendix X2. The thickness of the absorbed-dose enhancement region for Co-60 irradiation is of the order of hundreds of micrometres. Therefore, for example, in MOS

INTERFACE EFFECTS AT LOW ENERGIES (10–200 KeV)

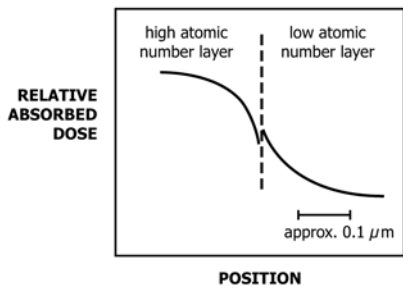

INTERFACE EFFECTS AT HIGH ENERGIES (APPROX. 1 MeV)

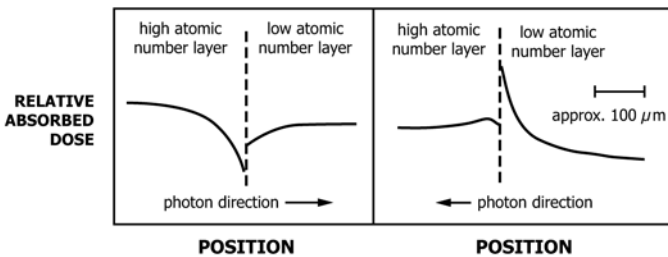

NOTE 1—(a) Schematic illustration of absorbed-dose enhancement effects at low photon energies. The actual magnitude of these effects depends on the energies and materials used. (b) Schematic illustration of absorbed-dose enhancement effects at high photon energies (3). Note that the vertical scales of Figs. 1(a) and 1(b) are not necessarily the same.

FIG. 1 Absorbed-Dose Enhancement Effects



devices where the critical gate oxide is 10–200 nm thick, the volume of interest will generally lie within the enhancement region.

6.3.6 Since mass energy absorption coefficients are a function of photon energy, the use of Eq 1 requires knowledge of the incident photon spectrum. However, for photon energies greater than 250 keV, ratios of mass energy absorption coefficients are slowly varying functions of photon energy (see Fig. X4.1). As a result it is often adequate to use the values of  $(\mu_{en}/\rho)_{\text{dosimeter}}$  and  $(\mu_{en}/\rho)_{\text{device}}$  tabulated for 1 MeV (see Appendix X4). For photon energies greater than 250 keV the errors introduced by this approximation are usually less than about 5%. The advantage of this approximation is that it requires no knowledge of the Co-60 source photon energy spectrum. Such spectrum information frequently is unavailable.

NOTE 9—Another consideration in absorbed-dose conversion is that the photons will generally have passed through somewhat different layers of material in going from the source to the dosimeter as compared to going from the source to the device under test. Therefore, the photon energy spectrum incident on the dosimeter will be different from that incident on the device. For Co-60 irradiations of electronic devices, these differences can be neglected if care is taken to make the irradiation geometry of the dosimeters and devices essentially the same. The resulting dosimetry errors are generally less than 10%.

#### 6.4 Examples of Conditions That May Lead to Large Absorbed-Dose Enhancement Effects:

6.4.1 A *soft spectrum* is typically caused by Compton scattering from low atomic number materials. It is particularly important in water well sources, if long water paths are used, and in room sources, if there is significant photon backscattering from walls and floors.

6.4.2 *High Atomic Number Materials* in devices or device packaging can lead to large effects. A common example of such a structure is the device packaged with a gold layer on the inside of a Kovar lid.

### 7. Procedures for Minimizing Dosimetry Errors Due to Absorbed-Dose Enhancement

7.1 The principal errors in dosimetry in Co-60 irradiation hardness testing of electronic devices are caused by absorbed-dose enhancement effects resulting from non-equilibrium electron transport. Such errors can be reduced by using appropriate procedures assuming that the dosimetry measurements are made correctly (See Practice E668 for the use of TLDs). The dosimeter shall be irradiated under the same conditions as the device under test (see 4.1.1).

#### 7.2 Minimizing Errors Due to Low Energy Photons:

7.2.1 Low energy absorbed-dose enhancement effects are due to low energy components of the Co-60 photon spectrum (see Section 5 and 6.1). This form of absorbed-dose enhancement can be reduced by spectrum hardening.

7.2.2 A filter box shall be used for spectrum hardening of all types of Co-60 sources described in Section 5. Such a box can be constructed with an outer layer of between 1.5 and 2.0 mm (approximately 0.063 in.) of Pb and an inner layer of between 0.7 and 1.0 mm (approximately 0.030 in.) of Al.

NOTE 10—The purpose of the indicated thickness of aluminum is to eliminate dose enhancement effects that could be caused by the lead layer.

This aluminum layer should be thick enough to produce an approximate charged particle equilibrium with the largely low atomic number materials usually present in devices. It can be seen from Fig. X5.1 that the absorbed-dose enhancement effects of a high atomic number material are largely eliminated after about 0.8 mm (about 0.03 in.) of aluminum.

7.2.3 For the teletherapy and room type sources, other procedures should be used in addition to the use of a filter box. Potential scatterers within the vicinity of the irradiation position or near the direct path of the radiation beam should be removed. Those potential scatterers that cannot be removed, including the walls, floor, and ceiling, should be covered with Pb, when practical (see X3.2.2).

7.2.4 In the case of room type sources, when the Co-60 is contained within an individual capsule, the effect of scattering from the walls, floor and ceiling can be estimated by exposing an appropriate dosimeter at different radial distances,  $r$ , from the source. If the dosimeter response shows no significant deviation from an inverse square law ( $1/r^2$ ), corrected if necessary for the calculated effects of infinite source and detector size, it may be concluded that, at the positions tested, no effects are present from scatterers, other than those associated with the support structures of the source and detector. An appropriate dosimeter in this context must be one capable of responding to low energy photons.

7.2.5 For a teletherapy source, proper collimators should be used and a beam trap can often be used effectively to reduce backscattering.

#### 7.3 Minimizing Errors Due to High Energy Photons:

7.3.1 A form of absorbed-dose enhancement is present even for relatively high energy Co-60 photons. This form of absorbed-dose enhancement cannot be reduced by the use of spectrum hardening, but can be minimized by proper device orientation (see X2.3).

7.3.2 The orientation of the plane of the semiconductor chip in the device under test shall be perpendicular to the incident radiation to the extent possible. The device shall be oriented with higher atomic number layers toward the incident radiation in order to minimize absorbed-dose enhancement effects. These requirements do not apply for irradiations in source geometries in which the photons are incident nearly isotropically on the device under test; for example, in a self-shielded cavity source or in the center of a cylindrical array of a water well or room source.

NOTE 11—An orientation to be avoided is that of a unidirectional beam directed so that it passes from a low-atomic-number material to a high-atomic-number material. For example, for a 1.25 MeV beam passing through aluminum to gold, an absorbed-dose enhancement factor as large as 1.5 has been reported (see X2.3).

7.4 If the procedures of 7.2 and 7.3 are used, the absorbed-dose enhancement factor is expected to be between 0.9 and 1.2 and, therefore, contributes no more than 20% to the dosimetry error (see Appendix X5).

NOTE 12—Dosimetry errors of less than 20% may be acceptable in many cases of radiation hardness testing of electronics. Appendix X5 indicates that without using these procedures, the absorbed-dose enhancement factor can be as large as five.

**8. Minimum Information for Test Reports**

8.1 *Source*—Type, source strength, and any information on a measured or calculated energy spectrum.

8.2 *Dosimeter System*—Type, calibration data, and relevant environmental conditions during the irradiation.

8.3 *Device*—Type, manufacturer, lot or batch number, and any available information on its specific construction.

8.4 *Irradiation Geometry*—Position and orientation of source and device under test as well as position and description

of materials or objects in the vicinity that could lead to either spectrum softening or spectrum hardening.

8.5 *Filter Box (or Can)*—Materials used, thicknesses, and dimensions.

**9. Keywords**

9.1 absorbed dose; Co-60 irradiation; dose enhancement; radiation hardness testing

**APPENDIXES**

(Nonmandatory Information)

**X1. TYPICAL <sup>60</sup>CO FACILITIES**

X1.1 This appendix provides simplified schematic diagrams of various types of available <sup>60</sup>Co irradiation facilities, along with tabular and graphical information on typical energy spectra for each source. Caution should be employed in using the spectral information for calculation or interpretation of absorbed dose or absorbed dose enhancement for any specific application. A given source spectrum may be altered significantly by the presence of scattering material, by a change in location relative to the source, and by other effects.

X1.2 Source and energy spectral information are provided in the following figures:

X1.2.1 Teletherapy source in Fig. X1.1 and Fig. X1.2,

X1.2.2 Room source in Fig. X1.3 and Fig. X1.4,

X1.2.3 Water well sources in Fig. X1.5 and Fig. X1.6, and

X1.2.4 Shielded-cavity irradiator in Fig. X1.7 and Fig. X1.8.

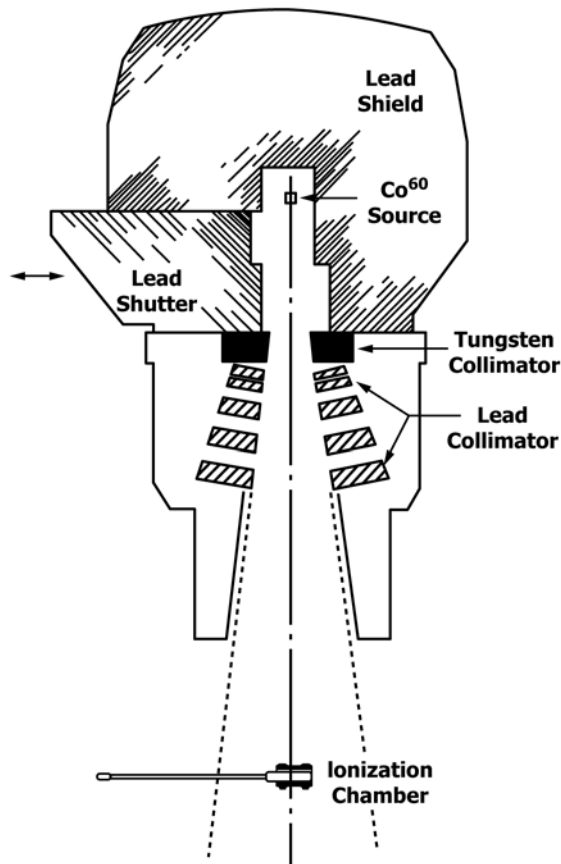
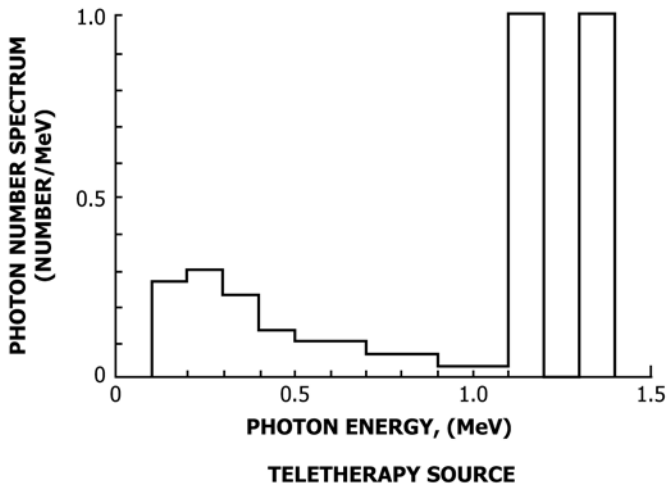
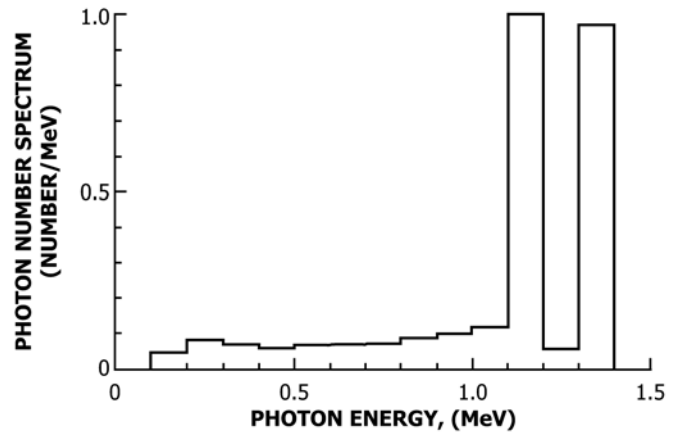

FIG. X1.1 Diagram of a Teletherapy Source (4)



(a)



(b)

FIG. X1.2 Typical Spectra for Two Types of Teletherapy Sources a(2) and b(4)

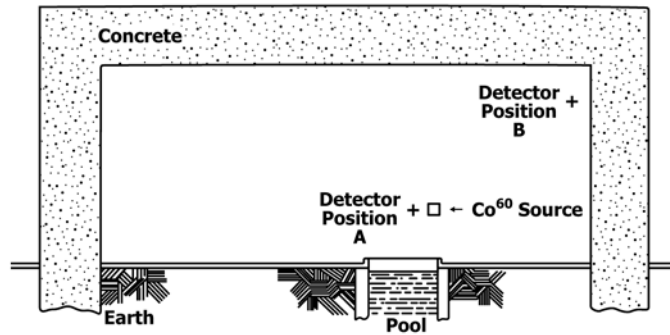

Facility at Harry Diamond Laboratories; Elevation

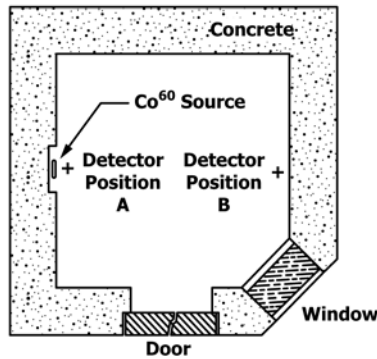

Facility at NASA - Goddard; Plan

FIG. X1.3 Diagrams of Two Typical Concrete Room Sources (5)

X1.3 Normalized photon energy spectra for various <sup>60</sup>Co sources are provided in Table X1.1 and Table X1.2.

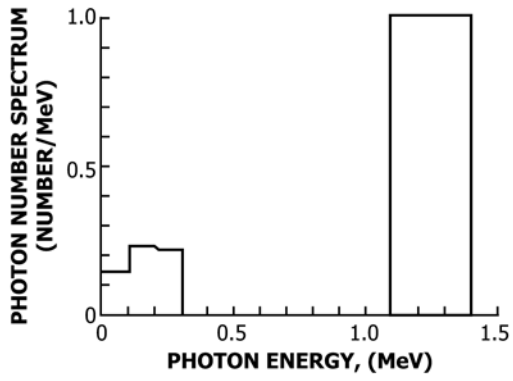

HDL CONCRETE ROOM, POS. A, NO FILTER

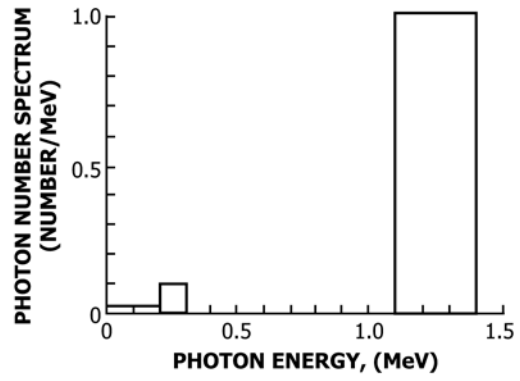

HDL CONCRETE ROOM, POS. A, .063" Pb

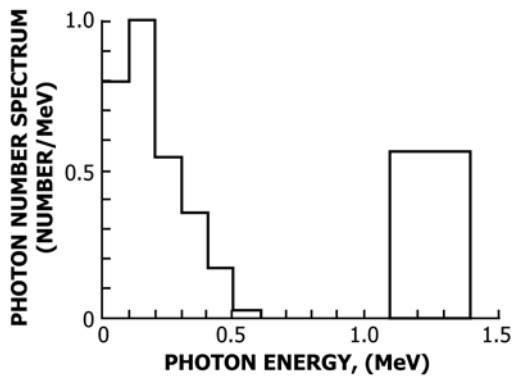

HDL CONCRETE ROOM, POS. B, NO FILTER

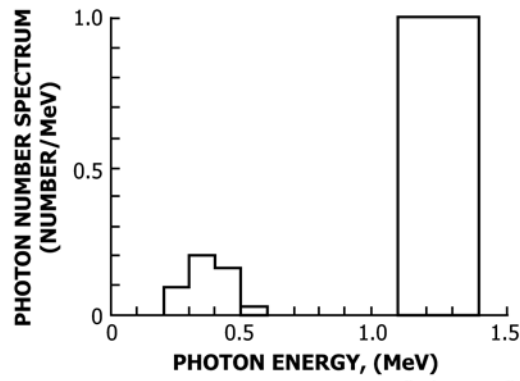

HDL CONCRETE ROOM, POS. B, .125" Pb - .030" Al

FIG. X1.4 Typical Spectra for Room Source Under Various Conditions (4)



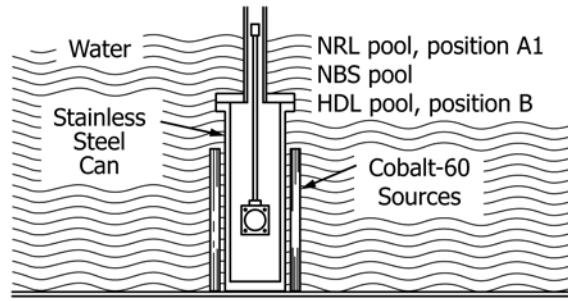

a.

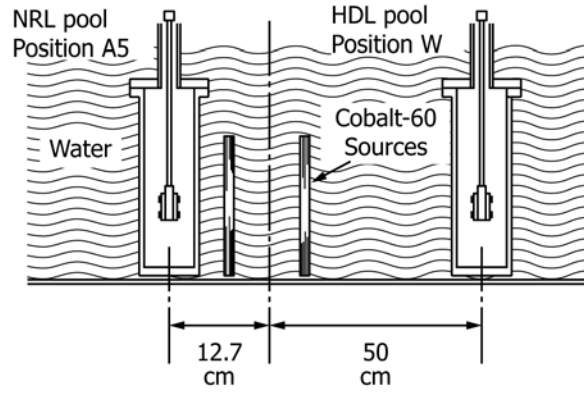

b.

FIG. X1.5 Diagrams of Two Types of Water Well Sources (5)

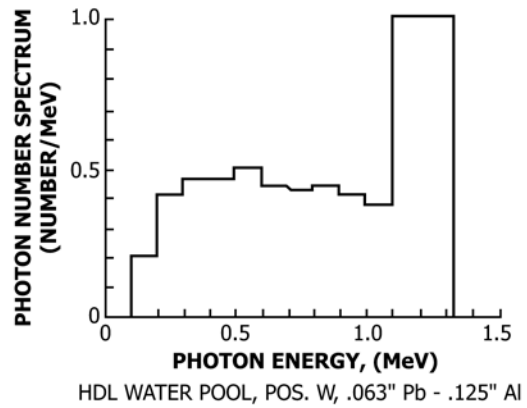
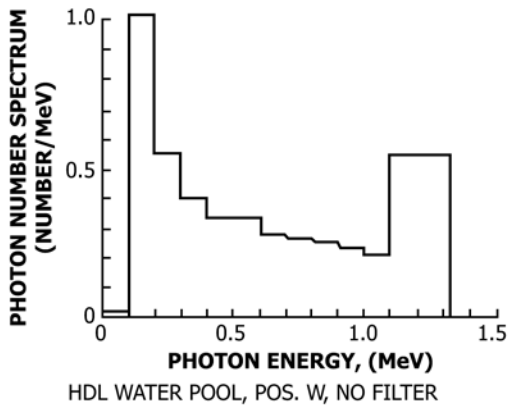
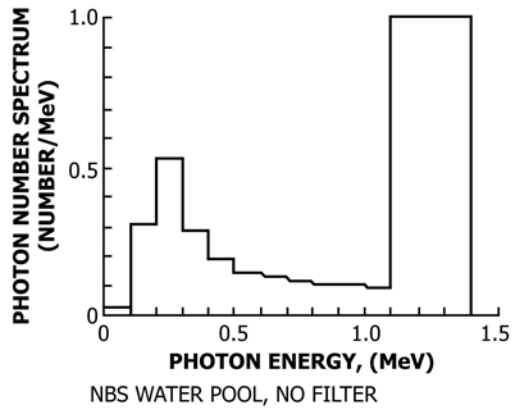

FIG. X1.6 Typical Spectra for Water Well Sources Under Various Conditions (4, 6)

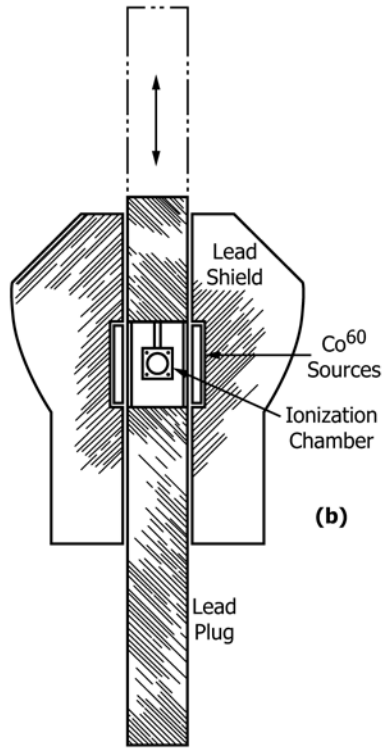

FIG. X1.7 Diagram of a Typical Shielded-Cavity Irradiator (5)

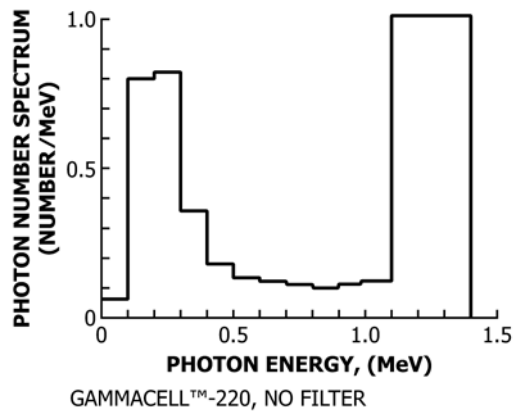

FIG. X1.8 Typical Spectrum for Shielded-Cavity Irradiator (4)

**TABLE X1.1 Normalized Photon Spectra for Various <sup>60</sup>Co Sources**

Energy Interval (MeV)	(See Table X1.2 for source descriptions.)									
	Source 1a (2)	Source 1b (4)	Source 2a (4)	Source 2b (4)	Source 2c (4)	Source 2d (4)	Source 3 (4)	Source 4a (6)	Source 4b (6)	Source 5 (4)
0–0.1	0	0.001	0.150	0.792	0.031	0	0.019	0.010	0	0.071
0.1–0.2	0.267	0.047	0.229	1.000	0.033	0.005	0.293	1.000	0.226	0.792
0.2–0.3	0.300	0.084	0.224	0.545	0.101	0.096	0.510	0.539	0.430	0.823
0.3–0.4	0.233	0.073	0.227	0.361	0.001	0.211	0.320	0.386	0.478	0.354
0.4–0.5	0.133	0.064	0	0.170	0	0.161	0.184	0.329	0.479	0.179
0.5–0.6	0.100	0.071	0	0.026	0	0.038	0.151	0.326	0.518	0.132
0.6–0.7	0.100	0.072	0	0.005	0	0.009	0.130	0.272	0.463	0.121
0.7–0.8	0.067	0.075	0	0	0	0	0.120	0.262	0.452	0.105
0.8–0.9	0.067	0.092	0	0	0	0	0.104	0.251	0.467	0.098
0.9–1.0	0.033	0.105	0	0	0	0	0.096	0.230	0.428	0.109
1.0–1.1	0.033	0.124	0	0	0	0	0.097	0.204	0.402	0.115
1.1–1.4			1.000	0.563	1.000	1.000	1.000	0.508	1.000	1.000
1.1–1.2	1.000	1.000								
1.2–1.3	0	0.064								
1.3–1.4	1.000	0.977								

**TABLE X1.2 Identification of Sources in Table X1.1**

Source Code	Source Description
1a	Collimated array of source rods in air.
1b	Teletherapy, 20 cm <sup>2</sup> area at 100 cm from source.
2a	HDL room source, position A, no filter.
2b	HDL room source, position B, no filter.
2c	HDL room source, position A, 1.6 mm Pb filter.
2d	HDL room source, position B, 3.2 mm Pb + 0.76 mm Al filter.
3	NBS water pool source, in center of array.
4a	HDL water pool source, position W, no filter.
4b	HDL water pool source, position W, 1.6 mm Pb + 3.2 mm Al filter.
5	Shielded-cavity irradiator, at center of chamber, no filter.

## X2. ABSORBED-DOSE ENHANCEMENT EFFECTS

### X2.1 General

X2.1.1 When photons deposit energy in objects that consist of regions having different atomic numbers, the deposition in a region of a specific material may be affected significantly by photon interactions in an adjacent different material. These effects depend strongly on the energy of the incident photons and, therefore, show significant differences at high and low photon energies (see 6.1 and Fig. 1).

### X2.2 Low-Energy Photon Effects (Compton Scattering, Photoelectric Absorption and Electron Transport)

X2.2.1 The origin of the low-energy photon spectrum component from a Co-60 source is the result of Compton scattering within the encapsulated source itself and material surrounding the source. Compton scattering in the walls, collimators and filters causes spectrum softening and can contribute especially to the low-energy spectrum of the source if the scattering material is primarily of low atomic number such as aluminum or concrete.

X2.2.2 For a thin layer of gold, more than 99 % of the energy transferred to the material is by photoelectric absorption for 100 keV photons, while about 30 % is transferred by photoelectric absorption for 1-MeV photons. For a thin layer of aluminum the corresponding values are about 65 % for 100-keV photons and less than 1 % for 1-MeV photons.

X2.2.3 Photoelectric absorption in a material is approximately proportional to the fourth power of the material's atomic number. Therefore, for this case of a gold layer adjacent to an aluminum layer, more photon energy will be transferred to the gold than to the aluminum. The photon energy is primarily transferred into kinetic energy of photoelectrons. The resulting electron transport produces a net flow of electrons from the gold into the aluminum. This corresponding energy transport results in an enhancement of absorbed dose in aluminum near the interface with a complimentary reduction of absorbed dose in gold at the interface (1, 7, 8).

### X2.3 High-Energy Photon Effects (Compton Scattering and Electron Transport)

X2.3.1 Photons with energies above 200 keV incident on aluminum transfer energy primarily through Compton scattering. For gold, the corresponding lower energy limit is about 1 MeV.

X2.3.2 The energy transfer to material through Compton scattering is not very dependent on photon energy or material atomic number. For example, the equilibrium absorbed doses in gold and aluminum for 1 MeV incident photons are much more similar than would have been the case if absorption had been dominated by the photoelectric process.

X2.3.3 The absorbed dose enhancement effects for photons of 1 MeV are significantly different from those that are

characteristic of photon energies below about 200 keV. These effects show a strong dependence on the direction of the incident photon beam relative to the material interface. For example, in the case of a collimated beam of 1.25-MeV photons normally incident on gold of a gold-aluminum interface, the absorbed dose in the gold near the interface is about 60 % of the absorbed dose far from the interface (3), while the absorbed dose in the aluminum near the interface is about 85 % of the value far from the interface. Correspondingly, if the photons are incident from the opposite direction, that is, first on the aluminum for the same material combination, then the absorbed dose levels near the interface as compared to large distances from it are 150 % in aluminum and 105 % in gold, respectively (see Fig. 1). An important part of the reason for this behavior can be deduced from two facts. First, the Compton electrons produced are scattered mainly in

the direction of the incident photon beam. Second, if electrons are normally incident upon a slab of material, the fraction of these electrons back-scattered is higher for a higher atomic number material. Therefore, if electrons are traveling from aluminum into gold, there will be substantial electron back-scattering from the gold, enhancing the absorbed dose in the aluminum. It also follows from this reasoning that photons incident parallel to the interface (and also isotropically incident photons) will give rise to relatively smaller absorbed-dose enhancement effects as compared to normally incident photons.

**NOTE X2.1**—The absorbed dose enhancement effects given for the gold-aluminum combination would be approximately the same as that expected for similar material combinations, such as gold-silicon and tantalum-silicon. However, the magnitude of the absorbed dose enhancement effects will be small when the difference in atomic numbers of the combined materials is small.

### **X3. FACTORS INFLUENCING THE INCIDENT PHOTON ENERGY SPECTRUM**

#### **X3.1 Filters and Scatterers**

**X3.1.1** Materials serve as filters and scatterers if located between the photon beam and a device under test, surrounding the device under test (for example, walls and the testing container), or behind the device under test. Photoelectric absorption provides a filtering action by preferentially removing low energy photons from the beam while Compton scattering can add significant numbers of low energy photons to the beam.

**X3.1.2** The balance of the effect between photoelectric absorption and Compton scattering depends on the atomic number of the material involved. In high atomic number materials (for example, lead, gold, and tantalum), filtration predominates and, hence, such materials can be used for spectrum hardening. In low atomic number material (for example, concrete, plastics, ceramics, and water), scattering predominates and, hence, such materials, which especially cause spectrum softening, are to be avoided. Intermediate atomic number materials (for example, iron) give rise to approximately equal effects from filtering and scattering.

**NOTE X3.1**—Some filters and scatterers add low energy photons to the

beam through fluorescence (characteristic x-rays). However, measurements and calculations indicate that fluorescence contributes negligibly to the absorbed dose in the critical regions of electronic devices (6).

#### **X3.2 Walls**

**X3.2.1** Walls around a device under test can contribute significantly to spectrum softening.

**X3.2.2** For a room source, measurements at the device location show that covering concrete walls with lead significantly reduces spectrum softening (9).

#### **X3.3 Collimators**

**X3.3.1** A collimator should be designed to minimize its own contribution to scattered photons.

**X3.3.2** Collimators, by defining the direction of the photon beam, can reduce scattering from the walls and materials surrounding the device under test (9, 10).

**X3.3.3** Collimators generally reduce absorbed dose enhancement effects by reducing undesired Compton scattering (see X3.3.2); however, they also may cause larger absorbed dose enhancement effects when compared to uncollimated sources because of directional effects (see 7.3 and X2.3.3).



X4. MASS ENERGY ABSORPTION COEFFICIENTS

X4.1 Mass energy absorption coefficients for several materials of interest in radiation hardness testing of electronics are given in Table X4.1 (II) (see 6.3.1).

X4.2 A plot of the ratios of mass energy absorption coefficients for various materials relative to silicon is given in Fig. X4.1. (See 6.3.1 and 6.3.2).

TABLE X4.1 Mass Energy Absorption Coefficients:  $\mu_{en}/\rho$  ( $\text{cm}^2/\text{g}$ ) and Mass Collision Stopping Powers:  $S/\rho$  ( $\text{MeV} \cdot \text{cm}^2/\text{g}$ )

Energy, MeV	Air		LiF		CaF <sub>2</sub>		Al		Si	
	$\mu_{en}/\rho$	$S/\rho$	$\mu_{en}/\rho$	$S/\rho$	$\mu_{en}/\rho$	$S/\rho$	$\mu_{en}/\rho$	$S/\rho$	$\mu_{en}/\rho$	$S/\rho$
0.01	4.7	19.8	5.73	18.0	48.7	16.7	25.4	16.5	32.9	16.9
0.02	0.539	11.6	0.649	10.6	6.69	9.95	3.09	9.84	4.08	10.1
0.04	0.0683	6.85	0.0789	6.25	0.841	5.97	0.360	5.91	0.478	6.07
0.06	0.030	5.11	0.0322	4.67	0.251	4.49	0.110	4.44	0.143	4.56
0.08	0.0241	4.20	0.0239	3.84	0.114	3.70	0.0551	3.66	0.0690	3.76
0.1	0.0233	3.63	0.0223	3.32	0.0674	3.21	0.0377	3.18	0.0451	3.27
0.2	0.0267	2.47	0.024	2.26	0.0311	2.20	0.0275	2.17	0.0291	2.24
0.4	0.0295	1.90	0.02743	1.74	0.0293	1.71	0.0286	1.68	0.0297	1.73
0.6	0.0295	1.74	0.0274	1.58	0.0289	1.56	0.0285	1.54	0.0295	1.59
0.8	0.0288	1.68	0.0267	1.52	0.0281	1.51	0.0278	1.49	0.0288	1.53
1.0	0.0279	1.66	0.0259	1.49	0.0272	1.48	0.0269	1.47	0.0278	1.51
2.0	0.0235	1.68	0.0217	1.47	0.0229	1.48	0.0227	1.48	0.0235	1.52
4.0	0.0187	1.79	0.0173	1.51	0.0193	1.53	0.0188	1.54	0.0196	1.59
6.0	0.0165	1.87	0.0153	1.55	0.0180	1.58	0.0174	1.58	0.0183	1.64
8.0	0.0153	1.93	0.0141	1.57	0.0176	1.61	0.0168	1.61	0.0177	1.67
10	0.0145	1.98	0.0135	1.59	0.0174	1.64	0.0165	1.64	0.0175	1.70
20	0.0131	2.13	0.0121	1.65	0.0176	1.71	0.0163	1.70	0.0176	1.77
40		2.28		1.71		1.77		1.77		1.84
60		2.35		1.74		1.81		1.81		1.87

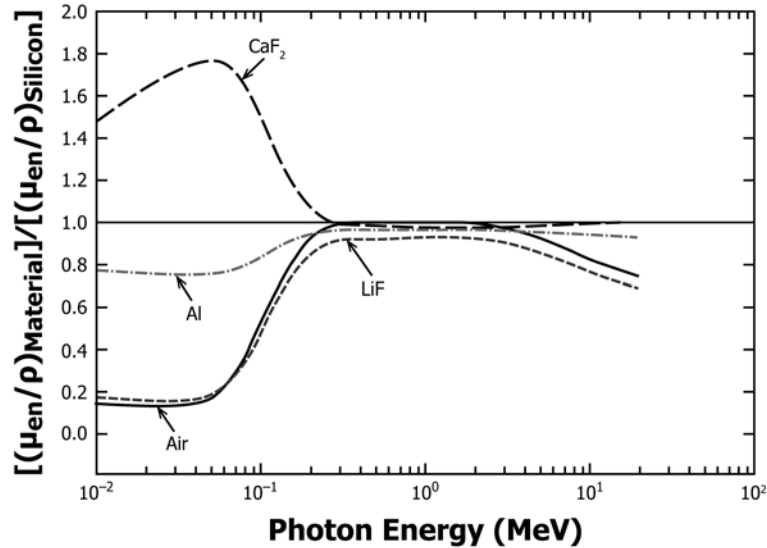

FIG. X4.1 Ratios of Mass Energy Absorption Coefficients of Various Materials Relative to That of Silicon

**X5. SUMMARY OF SOME CALCULATIONS AND MEASUREMENTS OF DOSIMETRY ERRORS IN Co-60 IRRADIATION OF ELECTRONIC DEVICES**

**X5.1 Measurement of Absorbed Dose Enhancement**

X5.1.1 Wall and Burke (12) measured absorbed dose enhancement at high-atomic-number/low-atomic-number interfaces irradiated by a “clean” Co-60 source. Measurements were made with a multiple, parallel-plate ionization chamber. An example of their results for aluminum adjacent to a thick layer of gold is shown in Fig. X5.1. The figure also indicates the dependence of absorbed dose on the direction of the incident photons. Similar, more recent measurements have been reported by Garth, Burke, and Woolf (2).

X5.1.2 Lowe, Cappelli, and Burke (9) have reported the effect of spectrum softening on absorbed dose enhancement effects. The measurements show the effects of placing various intermediate materials between the Co-60 source and a device under test. These materials serve to produce spectrum hardening by photoelectric absorption, spectrum softening by Compton scattering, and attenuation of the beam. The absorbed dose enhancement effects in aluminum of a gold-aluminum combination (with the photons incident on aluminum) were studied as a function of the thickness of the gold layer and as a function of the thickness and atomic number of the intermediate material. For intermediate materials of low atomic number (for example, aluminum or paraffin), the absorbed dose enhancement increased significantly, and the measured absorbed dose

enhancement factors were as large as seven. For intermediate materials of high atomic number, the absorbed dose enhancement was significantly lower because of spectrum hardening. For example, using a 6 mm thickness of lead as an intermediate material and a 1 μm thick gold layer on aluminum, the absorbed dose enhancement in aluminum was less than 20 %.

**X5.2 Measurement and Calculation of Absorbed Dose Enhancement Factors With and Without Spectrum Filtration**

X5.2.1 Brown and Dozier (13) calculated the absorbed dose enhancement effects for a MOS device in a hypothetical worst case geometrical arrangement using a calculated spectrum (2). The calculation was for the absorbed dose enhancement in the sensitive silicon-dioxide layer of a MOS device having a 500 nm layer of gold and a Kovar lid. Absorbed dose enhancement effects were divided into two parts: (a) those caused by photoelectric absorption and (b) those caused by Compton scattering. The results are summarized in Table X5.1. For the unfiltered case, the absorbed dose enhancement factor due to photoelectric absorption was 1.25 (that is a 25 % enhancement). An addition to the enhancement due to Compton scattering is estimated from reported measurements of Wall and Burke (12) and on calculations of Garth (3). In the worst case, in which a collimated photon beam passes through the SiO<sub>2</sub> layer toward the gold layer in the device, Compton scattering adds about 35 %; therefore, the absorbed dose enhancement factor in this case would be 1.25 + .35 = 1.60. In the best case in which a collimated photon beam passes from the gold layer into the SiO<sub>2</sub> layer, Compton scattering reduces the enhancement by 10 %, therefore, the absorbed dose enhancement factor in this case would be 1.25–0.1 = 1.15. Data do not exist for isotropic incidence, but in that case the enhancement due to Compton scattering is expected to be less than 10 %. The use of a lead filter of 1.6-mm (0.0625-in.) thick reduces the enhancement due to photoelectric absorption from 25 to 5 %; however, the lead filter would not significantly change the enhancement due to Compton scattering.

X5.2.2 Kelly, et al. (14) reported measurements of absorbed dose enhancement effects in CMOS dosimeters irradiated in a water-well and shielded-cavity Co-60 irradiator. The results are summarized in Table X5.2 for the water-well source irradiations and Table X5.3 for the irradiations in the shielded-cavity irradiator. Note that the results in both cases indicate a reduction in the absorbed dose enhancement factor when

**RELATIVE DOSE IN ALUMINUM NEXT TO GOLD FROM Co<sup>60</sup> γ-RAYS**

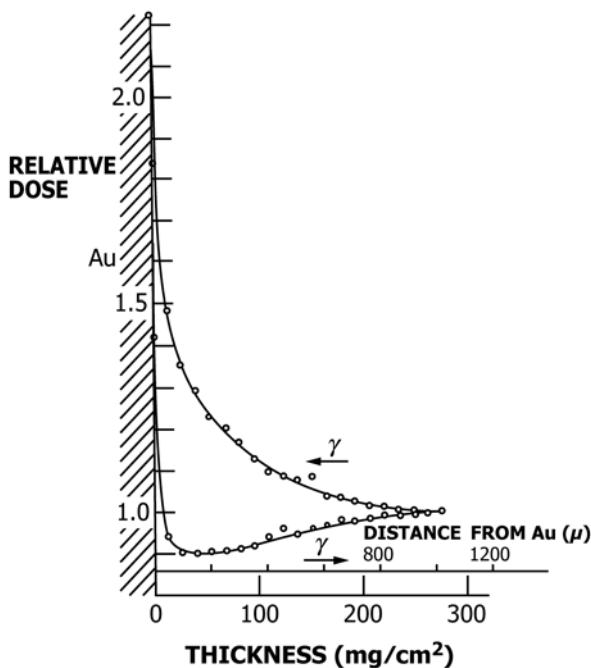

NOTE 1—Figure is from Reference 4.

**FIG. X5.1 Absorbed Dose Enhancement In Al Adjacent to Au With Co-60 Irradiation**

**TABLE X5.1 Ratio of Absorbed Dose in the SiO<sub>2</sub> Layer of an MOS Device After/Before Electron Transport**

Source	Filter	Dose SiO <sub>2</sub> (After Electron Transport)/Dose SiO <sub>2</sub> (Before Electron Transport)
Co-60 (teletherapy)	none	1.25 (+ 35 %, - 10 %)
Co-60 (teletherapy)	1.6 mm Pb	1.05 (+ 35 %, - 10 %)

**TABLE X5.2 Absorbed Dose Enhancement Factor for CMOS Dosimeters Irradiated in a Water-Well Source**

Measurement Setup	Absorbed Dose Enhancement Factor
Without filter; lid away from source	1.59
Without filter; lid toward source	1.12
With filter; lid away from source	1.15

**TABLE X5.3 Absorbed Dose Enhancement Factor for CMOS Dosimeters Irradiated in Shielded-Cavity Irradiator**

Measurement Setup	Absorbed Dose Enhancement Factor
Without Pb/Al filter	1.53
With Pb/Al filter	1.17

filtration is used. [Table X5.2](#) also shows the effects of orientation; that is, results when the devices under test were rotated 180° from their original irradiation position. In the water-well source, the devices under test were irradiated in a location where the photons were incident anisotropically.

X5.2.3 Long, Millward, and Wallace ([1](#)) reviewed results for both measured and calculated absorbed dose enhancement factors for a variety of irradiation sources and device configurations. Their data are summarized in [Table X5.4](#). A more extensive review of these data has been reported by Long, Millward, Fitzwilson, and Chadsey ([15](#)).

X5.2.4 Woolf and Fredrickson ([6](#)) calculated absorbed dose enhancement effects in aluminum adjacent to gold when irradiated in a water-well source. They reported a large dose enhancement factor of 5.4 for the case of 81 cm of water being between the source and the device under test; however, when

**TABLE X5.4 Absorbed Dose Enhancement Factors for Various Device Metallization Types and Packages**

Type of Chip Metallization	Type of Package	Dose Enhancement Factors for Co-60 Incidence Angle = 0° and 180°
aluminum or silicon	ceramic	1.0–1.0
	kovar	1.2–1.6
	gold	1.4–2.2
Shotky metallization	ceramic	1.3–1.9
	kovar	1.3–1.9
	gold	1.4–2.2
gold metallization	all	1.4–2.2

the device under test was irradiated in a lead-lined, stainless-steel container at the same distance from the source, the absorbed dose enhancement factor was reduced to 2.0. The calculation was for a container having thicknesses of 1.25 mm of stainless steel and 2.3 mm of lead.

X5.2.5 Kerris and Gorbics ([5](#)) have reported using ionization chambers with aluminum and gold electrodes to measure the relative importance of the low-energy photon spectral component in various Co-60 sources (see Method [E1250](#)). Their results are summarized in [Table X5.5](#). The ratio of ionization chamber currents obtained when using gold electrodes to that using aluminum electrodes ( $I_{Au}/I_{Al}$ ) provides a figure of merit at a particular location within a source. The figure of merit, which is proportional to the low-energy photon spectral component, can be related to the absorbed dose enhancement factor for a gold-aluminum interface.

**TABLE X5.5 Measured Ionization Chamber Response Ratios,  $I_{Au}/I_{Al}$** 

Cobalt-60 Source Configuration <sup>A</sup>	Position	$I_{Au}/I_{Al}$ No filter	Filter Pb + Al, mm	$I_{Au}/I_{Al}$ W/Filter
NBS teletherapy source		2.18	1.9 + 0.43	2.07
HDL concrete room	A	2.70	1.6 + 0.76	2.14
NRL water well	Al	2.71	1.6 + 0.76	2.02
NASA concrete room	A	2.93	1.6 + 0.76	2.21
NBS water well		2.98	1.6 + 0.76	2.04
HDL water well	B	3.23	1.6 + 0.76	2.11
NASA gammacell-220		3.53	1.6 + 0.76	2.17
NRL water well	A5	3.86	1.9 + 0.43	2.28
NASA concrete room	B	6.17	1.6 + 0.76	3.27
HDL water well	W	7.40	1.6 + 3.2	3.53
HDL concrete room	B	7.56	3.2 + 0.76	2.52

<sup>A</sup>NBS—National Institute of Standards and Technology (formerly the National Bureau of Standards); HDL—Army Research Laboratory (formerly the Harry Diamond Laboratories); NRL—Naval Research Laboratory; and NASA—National Aeronautics and Space Administration (Goddard Space Flight Center). The measurement positions indicated are those shown in the source diagrams in [Appendix X1](#).

## REFERENCES

- (1) Long, D.M., Millward, D.J., and Wallace, J., "Dose Enhancement Effects in Semiconductor Devices," *IEEE Transactions on Nuclear Science*, NS-29, 1982, p. 1980.
- (2) Garth, J.C., Burke, E.A., and Woolf, S., "The Role of Scattered Radiation in the Dosimetry of Small Device Structures," *IEEE Transactions on Nuclear Science*, NS-27, 1980, p. 1459.
- (3) Garth, J., "High Energy Extension of the Semi-Empirical Model for Energy Deposition at Interfaces," *IEEE Transactions on Nuclear Science*, NS-28, 1981, p. 4145.
- (4) Woolf, S., and Burke, E.A., "Monte Carlo Calculations of Irradiation Test Photon Spectra," *IEEE Transactions on Nuclear Science*, NS-31, 1984, p. 1089.
- (5) Kerris, K.G., and Gorbics, S.G., "Experimental Determination of the Low-Energy Spectral Component of Cobalt-60 Sources," *IEEE Transactions on Nuclear Science*, NS-32, 1985, p. 4356.
- (6) Woolf, S., and Fredrickson, A.R., "Photon Spectra in <sup>Co</sup>60- $\gamma$  Test Cells," *IEEE Transactions on Nuclear Science*, NS-30, 1983, p. 4371.
- (7) Garth, J.C., Chadsey, W.L., and Sheppard, R.L., Jr., "Monte Carlo Analysis of Dose Profiles Near Photon Irradiated Material Interfaces," *IEEE Transactions on Nuclear Science*, NS-22, 1975, p. 2562.
- (8) Brown, D.B., "Photoelectron Effects on the Dose Deposited in MOS Devices by Low Energy X-Ray Sources," *IEEE Transactions on Nuclear Science*, NS-27, 1980, p. 1465.
- (9) Lowe, L.F., Cappelli, J.R., and Burke, E.A., "Dosimetry Errors in Co-60 Gamma Cells Due to Transition Zone Phenomena," *IEEE Transactions on Nuclear Science*, NS-29, 1982, p. 1992.
- (10) Fredrickson, A.R., "Gamma Energy Spectra for the RADC/ES Cobalt 60 Sources," *Rome Air Development Center Report*, RADC-TR-79-68 April 1979.
- (11) Hubbell, J. H., and Seltzer, S. M., *Tables of X-Ray Mass Attenuation Coefficients and Mass Energy-Absorption Coefficients* (version 1.4), [Online], Available: <http://physics.nist.gov/xaamdi>, National Institute of Standards and Technology, Gaithersburg, MD, 2004.
- (12) Wall, J., and Burke, E.A., "Gamma Dose Distributions at and Near the Interface of Different Materials," *IEEE Transactions on Nuclear Science*, NS-17, 1970, p. 305.
- (13) Brown, D.B., and Dozier, C.M., "Reducing Errors in Dosimetry Caused by Low Energy Components of Co-60 and Flash X-Ray Sources," *IEEE Transactions on Nuclear Science*, NS-29, 1982, p. 1996.
- (14) Kelly, J.G., Luera, T.F., Posey, L.D., Vehar, D.W., Brown, D.B., and Dozier, C.M., "Dose Enhancement Effects in MOSFET IC's Exposed in Typical <sup>60</sup>Co Facilities," *IEEE Transactions on Nuclear Science*, NS-30, 1983, p. 4388.
- (15) Long, D.M., Millward, D.G., Fitzwilson, R.L., and Chadsey, W.L., "Handbook for Dose Enhancement Effects in Electronic Devices," *Rome Air Development Center Report*, RADC-TR-83-84 March 1983.

ASTM International takes no position respecting the validity of any patent rights asserted in connection with any item mentioned in this standard. Users of this standard are expressly advised that determination of the validity of any such patent rights, and the risk of infringement of such rights, are entirely their own responsibility.

This standard is subject to revision at any time by the responsible technical committee and must be reviewed every five years and if not revised, either reapproved or withdrawn. Your comments are invited either for revision of this standard or for additional standards and should be addressed to ASTM International Headquarters. Your comments will receive careful consideration at a meeting of the responsible technical committee, which you may attend. If you feel that your comments have not received a fair hearing you should make your views known to the ASTM Committee on Standards, at the address shown below.

This standard is copyrighted by ASTM International, 100 Barr Harbor Drive, PO Box C700, West Conshohocken, PA 19428-2959, United States. Individual reprints (single or multiple copies) of this standard may be obtained by contacting ASTM at the above address or at 610-832-9585 (phone), 610-832-9555 (fax), or [service@astm.org](mailto:service@astm.org) (e-mail); or through the ASTM website ([www.astm.org](http://www.astm.org)). Permission rights to photocopy the standard may also be secured from the Copyright Clearance Center, 222 Rosewood Drive, Danvers, MA 01923, Tel: (978) 646-2600; <http://www.copyright.com/>