



# Standard Specification for Weighing and Drying Apparatus for Microchemical Analysis<sup>1</sup>

This standard is issued under the fixed designation E124; the number immediately following the designation indicates the year of original adoption or, in the case of revision, the year of last revision. A number in parentheses indicates the year of last reapproval. A superscript epsilon ( $\epsilon$ ) indicates an editorial change since the last revision or reapproval.

## 1. Scope

1.1 This specification covers apparatus used for weighing and drying operations in microchemical laboratory practice.

1.2 The values stated in inch-pound units are to be regarded as the standard. The metric equivalents may be approximate.

NOTE 1—This specification was originally developed by the Committee on Microchemical Apparatus, Division of Analytical Chemistry, American Chemical Society.<sup>2</sup>

## 2. Referenced Documents

2.1 *ASTM Standards*:<sup>3</sup>

E671 Specification for Maximum Permissible Thermal Residual Stress in Annealed Glass Laboratory Apparatus

E920 Specification for Commercially Packaged Laboratory Apparatus

E921 Specification for Export Packaged Laboratory Apparatus

E1133 Practice for Performance Testing of Packaged Laboratory Apparatus for United States Government Procurements

E1157 Specification for Sampling and Testing of Reusable Laboratory Glassware

## 3. Combustion Boats

3.1 Combustion boats of three sizes shall conform to the requirements in Table 1 and Fig. 1, Fig. 2, and Fig. 3. These boats shall be made of platinum-rhodium alloy containing 3.5 % rhodium.

<sup>1</sup> This specification is under the jurisdiction of ASTM Committee E41 on Laboratory Apparatus and is the direct responsibility of Subcommittee E41.01 on Laboratory Ware and Supplies.

Current edition approved Sept. 1, 2016. Published September 2016. Originally approved in 1956. Last previous edition approved in 2010 as E124 – 94 (2010). DOI: 10.1520/E0124-94R16.

<sup>2</sup> See the “1949 Report on Recommended Specifications for Microchemical Apparatus, Carbon-Hydrogen, Dumas Nitrogen, Sulfur and Halogen,” *Analytical Chemistry*, Vol 21, December 1949, p. 1555; and the “1953 Report on Recommended Specifications for Microchemical Apparatus, Weighing and Drying,” *Analytical Chemistry*, Vol 26, July 1954, p. 1186.

<sup>3</sup> For referenced ASTM standards, visit the ASTM website, [www.astm.org](http://www.astm.org), or contact ASTM Customer Service at [service@astm.org](mailto:service@astm.org). For *Annual Book of ASTM Standards* volume information, refer to the standard’s Document Summary page on the ASTM website.

## 4. Weighing Bottles

4.1 Weighing bottles of seven capacities shall conform to the requirements in Table 2 and Figs. 4-9, inclusive.

## 5. Weighing Cup

5.1 The weighing cup shall conform to the requirements shown in Fig. 11, and shall be made of platinum-rhodium alloy containing 3.5 % rhodium. The cup is designed to be used as a sample container to fit into the weighing bottle shown in Fig. 5, and is useful for weighing hygroscopic materials.

## 6. Weighing Tubes

6.1 Weighing tubes of three types shall conform to the requirements shown in Fig. 12, Fig. 13, and Fig. 14. These tubes should preferably be made of soda-lime glass.

## 7. Spatulas

7.1 Spatulas of four types, and preferably made of stainless steel, shall conform to the following requirements:

7.1.1 *Type A* (Fig. 15)—This spatula is generally useful. The top can be used for crushing crystals and the bent blade for scraping containers.

7.1.2 *Type B* (Fig. 16)—This spatula has a flat bent portion at one end and a V-shaped scoop at the other end. It is particularly useful for weighing samples.

7.1.3 *Type C* (Fig. 17)—This spatula is suitable for the larger samples commonly encountered in semimicro and preparative work. It has a U-shaped scoop at one end and a V-shaped scoop at the other end. The spatula can be used to add shot or beads to tare flasks and for measuring and introducing solid reagent into combustion tubes.

7.1.4 *Type D* (Fig. 18)—This spatula is useful in many microchemical applications.

## 8. Forceps

8.1 Forceps of two types, made of nickel-plated steel, shall conform to the following requirements:

8.1.1 *Forceps with Platinum—5 % Ruthenium Tips* (Fig. 19) The pin serves as a stop to prevent the forceps from being depressed to such an extent that the tips can open, allowing the held object to drop. When pressed together, the tips make contact for a distance of ¼ to ½ in. (6.4 to 12.7 mm).

NOTE 2—Depending upon the intended use, other materials may be

substituted for the platinum alloy. The construction and over-all dimensions should be identical with those shown in Fig. 19.

8.1.2 *Forceps with Conical Tapered Holders* (Fig. 20)—These forceps shall be made of spring steel. They are useful for handling weighing tubes, absorption tubes, filter tubes, etc.

## 9. Tare Flasks

9.1 Tare flasks of three types, made of soda-lime glass, shall conform to the requirements shown in Fig. 21, Fig. 22, and Fig. 23. The serial numbers shall be etched on the flasks.

## 10. Metal Cooling Block

10.1 The metal cooling block shall conform to the requirements shown in Fig. 24, and shall be made of a metal or alloy with a high heat conductivity. The surface should be highly resistant to abrasion and corrosion.

## 11. Metal Crucible Container with Glass Cover

11.1 This assembly shall conform to the requirements shown in Fig. 25, and shall consist of an aluminum body and a borosilicate-glass cover. It may be used in combination with the metal cooling block, Fig. 24. The combination, commonly termed a “microdesiccator,” serves primarily as a container for cooling, storage, and safe transportation of microweighing equipment.

## 12. Micro Glass Desiccator with Metal Insert

12.1 The micro glass desiccator shall conform to the requirements shown in Fig. 26. It shall consist of a glass

desiccator with cover and an aluminum insert which shall hold securely the metal cooling block, Fig. 24. This combination serves the same purpose as that described in Section 11, but permits the additional use of drying agents of other chemicals in the bottom container.

## 13. Drying Apparatus

13.1 The drying apparatus shall be of the Abderhalden type and shall conform to the requirements shown in Fig. 27.

NOTE 3—The shape of the tube attached to the ball joint, in the desiccator bulb, is intended to prevent desiccant from being carried over into the sample when the vacuum is broken. A cap for the ball joint and stopper for the standard taper 40/50 joint may be used to protect the desiccant when the bulb is disconnected and stands alone. The upward indentation in the vapor tube prevents cooling of the drying chamber by cold condensate.

## 14. Maximum Permissible Thermal Residual Stress

14.1 The stress in all glass items described herein shall conform to Specification E671.

## 15. Sampling and Testing

15.1 For glass items, refer to Specification E1157.

## 16. Packaging

16.1 For packaging, select from Specification E920 or E921, or Practice E1133.

## 17. Keywords

17.1 apparatus; microchemical; weighing and drying

TABLE 1 Combustion Boats

Size	Figure	Use	Approximate Weight, g
A	1	for samples of 1 to 5 mg <sup>A</sup>	0.45
B	2	for samples of 5 to 25 mg <sup>A</sup>	0.7
C	3	for samples over 25 mg <sup>A,B</sup>	1.5

<sup>A</sup> For drying procedures, the Size A boat is used with the weighing bottle, Fig. 8. Sizes B and C can be used either with the metal weighing bottles, Figs. 9 and 10, respectively, or with the glass weighing bottles, pig-type, Figs. 6 and 7.

<sup>B</sup> The Size C boat is especially suitable for bulky materials and explosive substances, and for holding glass capillaries containing liquid samples.

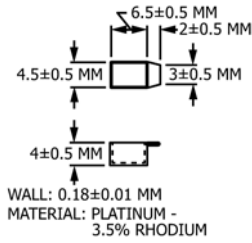

FIG. 1 Combustion Boat, Size A

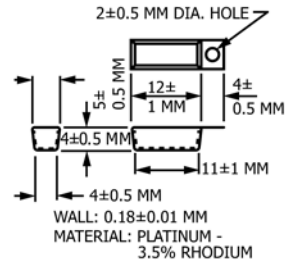

FIG. 2 Combustion Boat, Size B

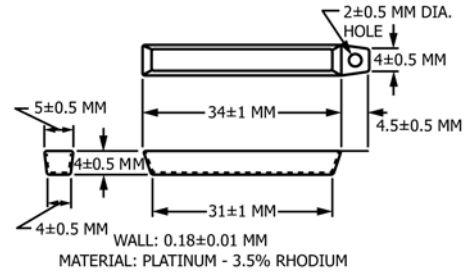

FIG. 3 Combustion Boat, Size C

**TABLE 2 Weighing Bottles**

Figure	Approximate Capacity, mL	Approximate Weight, g	Material
4 <sup>A</sup>	0.05	0.6	borosilicate glass
5	0.75	2.5	soda-lime glass
6 <sup>B</sup>	3	5.0	soda-lime glass
7 <sup>B,C</sup>	3	5.7	soda-lime glass
8 <sup>D</sup>	0.5	1.5	aluminum alloy
9 <sup>D</sup>	1	4.5	aluminum alloy
0 <sup>D</sup>	2	6	aluminum alloy

<sup>A</sup> This bottle is intended for introducing samples into containers of small diameters.

<sup>B</sup> The cap of the bottle shown in Fig. 5 may be used instead of the caps with rod handle shown in Figs. 6 and 7.

<sup>C</sup> This bottle, Fig. 7, is used for extremely hygroscopic materials; only the small cap is removed for vacuum drying, and it is replaced as soon as the vacuum is released. The bottle containing the combustion boat with sample may be attached to a combustion tube by means of a rubber adapter, and the boat pushed into position in the tube by passing a wire through the small joint.

<sup>D</sup> These bottles are designed for use in conjunction with the combustion boats, Figs. 1-3, as follows:

Bottle	Use with Boat
Fig. 8	Fig. 1
Fig. 9	Fig. 2
Fig. 10	Fig. 3

The combination is useful for weighing and drying extremely hygroscopic material. Sample, boat, and bottle are weighed, and the combination, without removing the cap, is placed in the drying apparatus (Fig. 27). During drying, vapors escape through the capillary. After drying, the combination is reweighed.

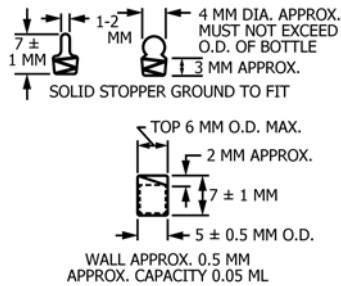

**FIG. 4 Weighing Bottle**

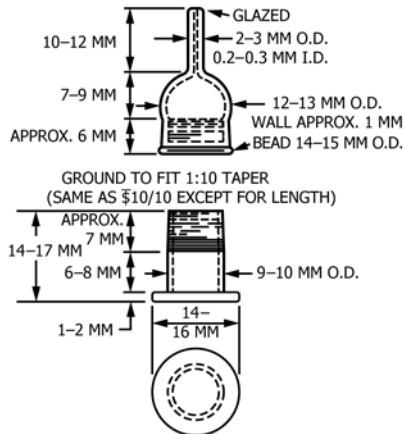

**FIG. 5 Weighing Bottle, Outside Cap**

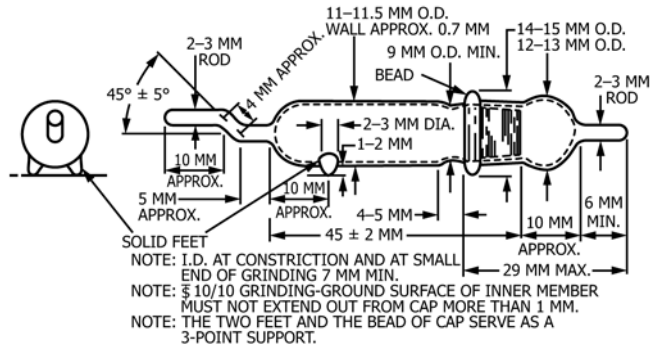
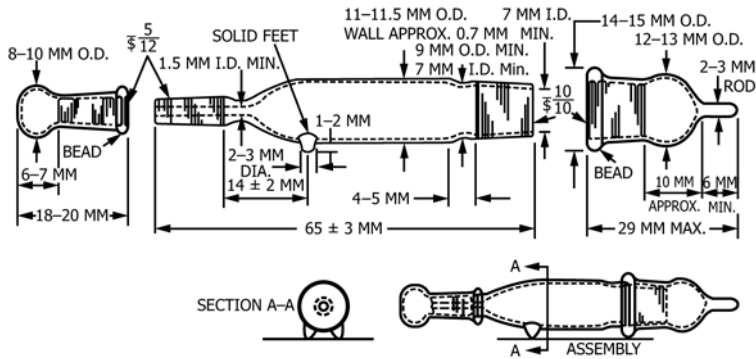
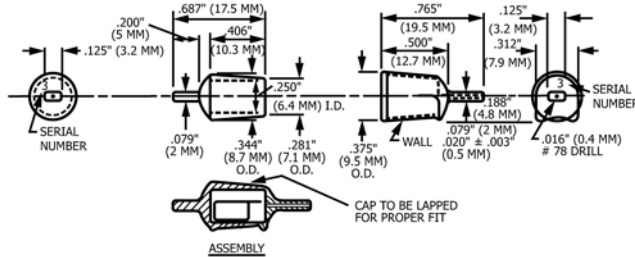

FIG. 6 Weighing Bottle, Pig-Type, with Outside Caps



NOTE: THE TWO FEET AND THE BEAD OF THE LARGER CAP SERVE AS A 3-POINT SUPPORT.  
 NOTE: § GRINDINGS - GROUND SURFACES OF INNER MEMBERS MUST NOT EXTEND OUT FROM CAPS MORE THAN 1 MM

FIG. 7 Weighing Bottle, Pig-Type, with Two Caps



NOTE: DIMENSIONS TO HAVE TOLERANCE OF ±.010" UNLESS OTHERWISE SPECIFIED.  
 DIMENSIONS IN MILLIMETERS ARE APPROXIMATE.

FIG. 8 Weighing Bottle, Pig-Type, Metal, Size A

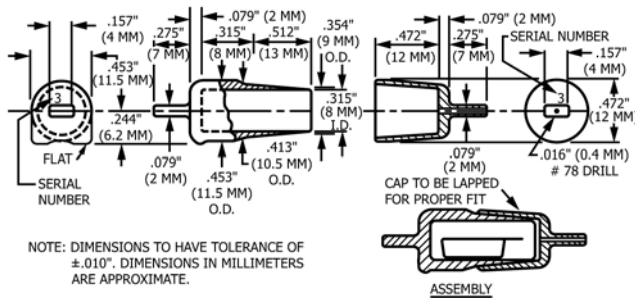

NOTE: DIMENSIONS TO HAVE TOLERANCE OF ±.010". DIMENSIONS IN MILLIMETERS ARE APPROXIMATE.

FIG. 9 Weighing Bottle, Pig-Type, Metal, Size B

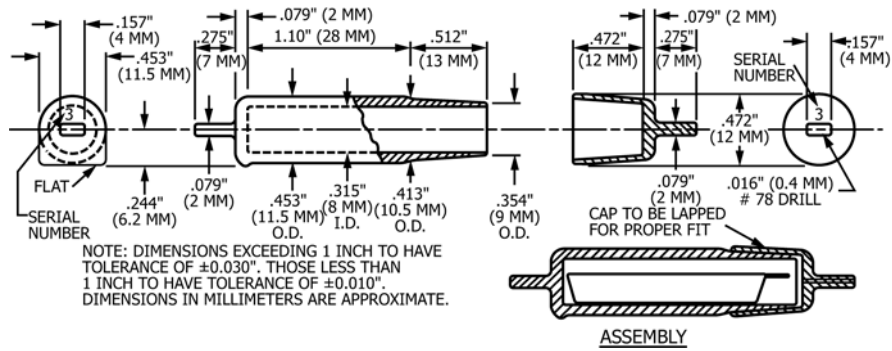

FIG. 10 Weighing Bottle, Pig-Type, Metal, Size C

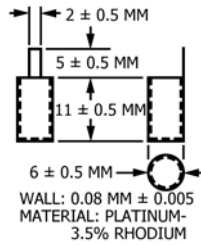

FIG. 11 Weighing Cup

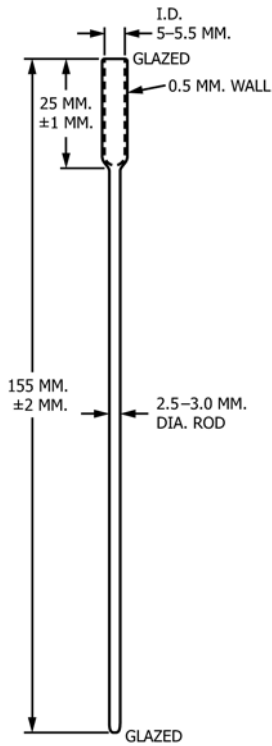

FIG. 12 Weighing Tube

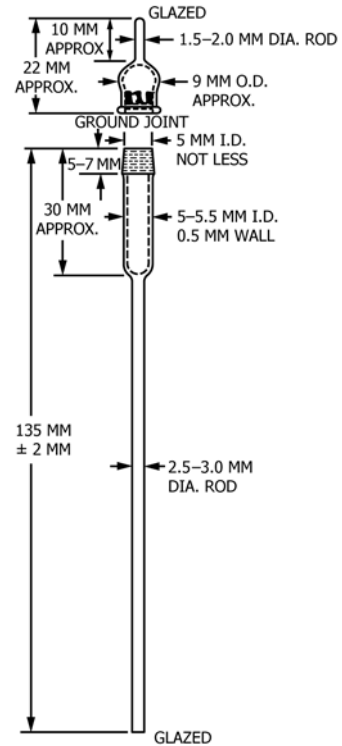

FIG. 13 Weighing Tube with Cap

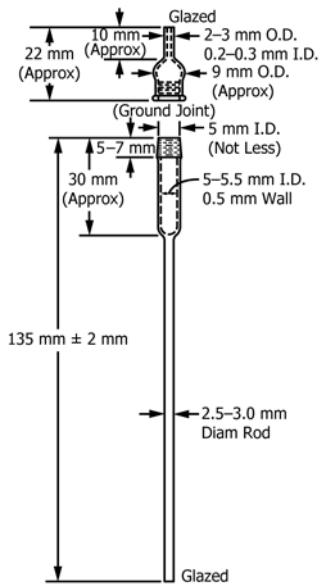

FIG. 14 Weighing Tube with Vented Cap

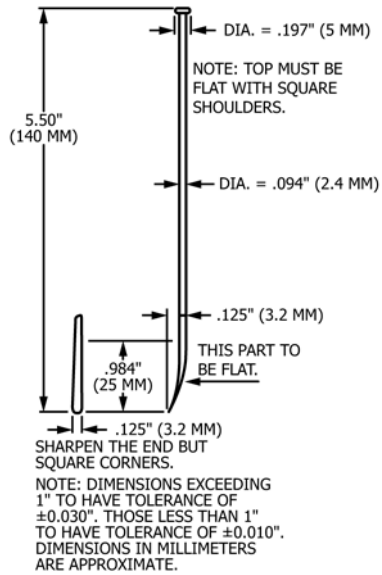

FIG. 15 Spatula, Metal, Type A

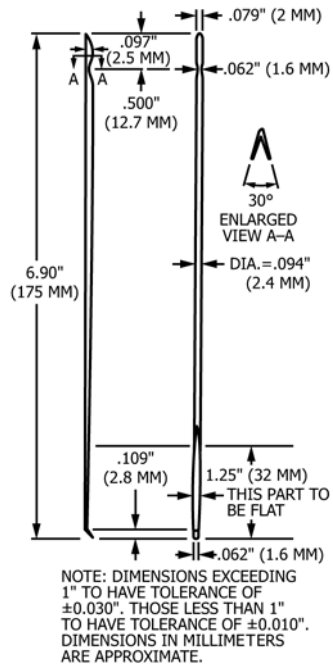

FIG. 16 Spatula, Metal, Type B

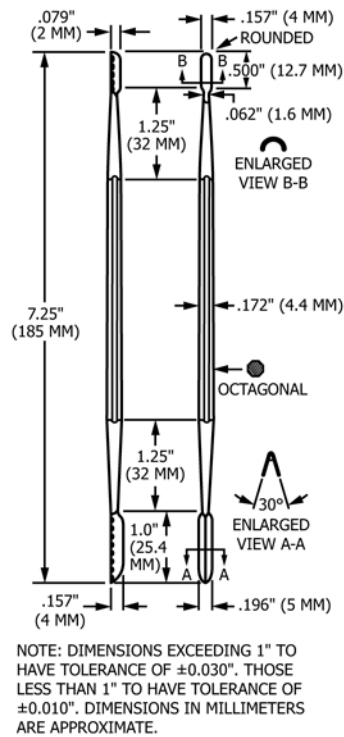
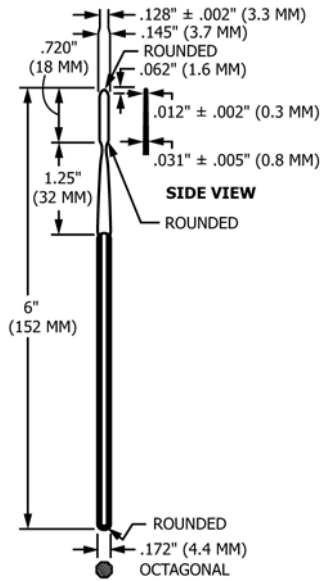

FIG. 17 Spatula, Metal, Type C





NOTE: DIMENSIONS EXCEEDING 1" TO HAVE TOLERANCE OF  $\pm 0.030"$ . THOSE LESS THAN 1" TO HAVE TOLERANCE OF  $\pm 0.010"$  UNLESS OTHERWISE SPECIFIED. DIMENSIONS IN MILLIMETERS ARE APPROXIMATE.

FIG. 18 Spatula, Metal, Type D

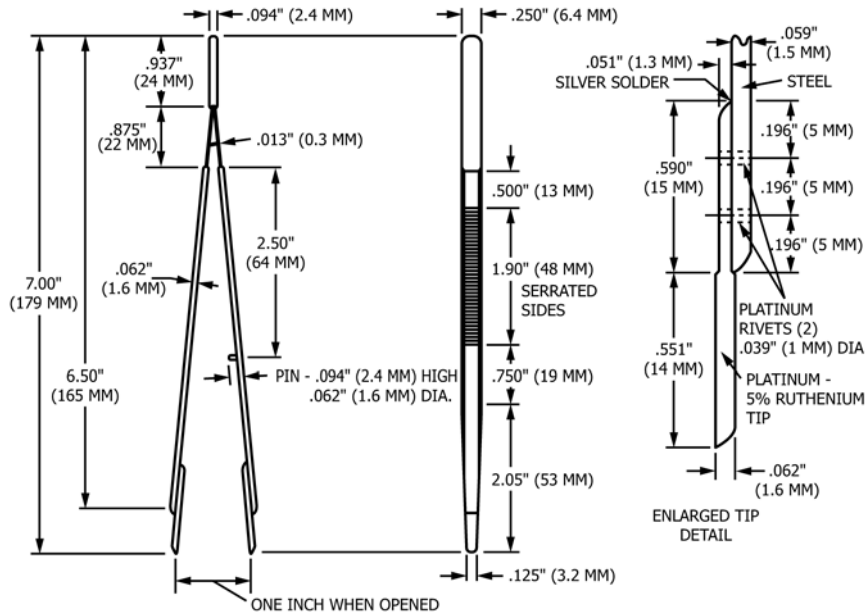

NOTE: DIMENSIONS EXCEEDING 1 INCH TO HAVE TOLERANCE OF  $\pm 0.030"$  THOSE LESS THAN 1 INCH. TO HAVE TOLERANCE OF  $\pm 0.010"$ . DIMENSIONS IN MILLIMETERS ARE APPROXIMATE.  
 PLATINUM TIPS: WHEN PRESSED TOGETHER SHOULD BE FLUSH FOR A DISTANCE OF .25" TO .5".

FIG. 19 Steel Forceps (Nickel Plated) with Platinum - 5 % Ruthenium Tips

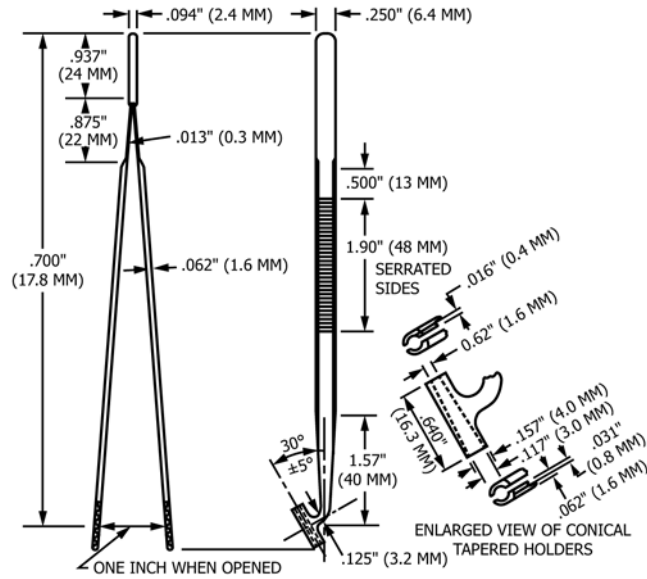

NOTE: DIMENSIONS EXCEEDING 1 INCH TO HAVE TOLERANCE OF  $\pm 0.030$ ". THOSE LESS THAN 1 INCH TO HAVE TOLERANCE OF  $\pm 0.010$ ". DIMENSIONS IN MILLIMETERS ARE APPROXIMATE.

FIG. 20 Steel Forceps (Nickel Plated) with Conical Tapered Holders

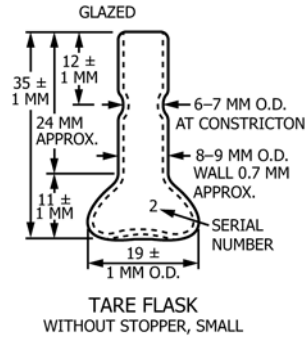

FIG. 21 Tar Flask, Without Stopper, Small

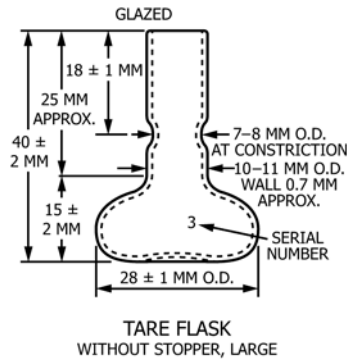

FIG. 22 Tare Flask, Without Stopper, Large

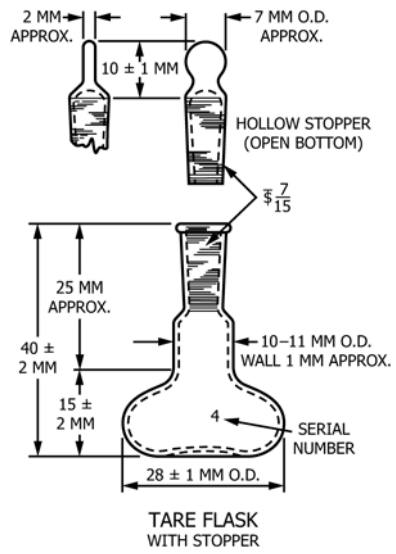

FIG. 23 Tare Flask with Stopper

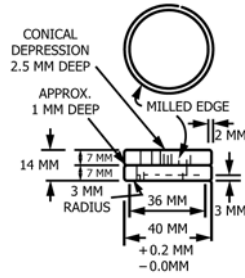

FIG. 24 Metal Cooling Block

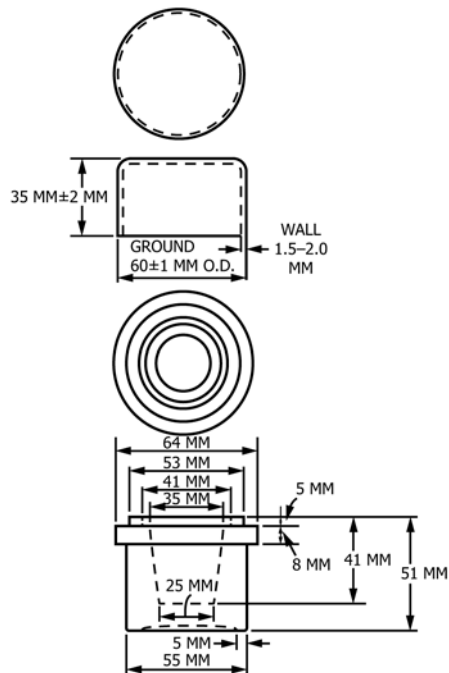
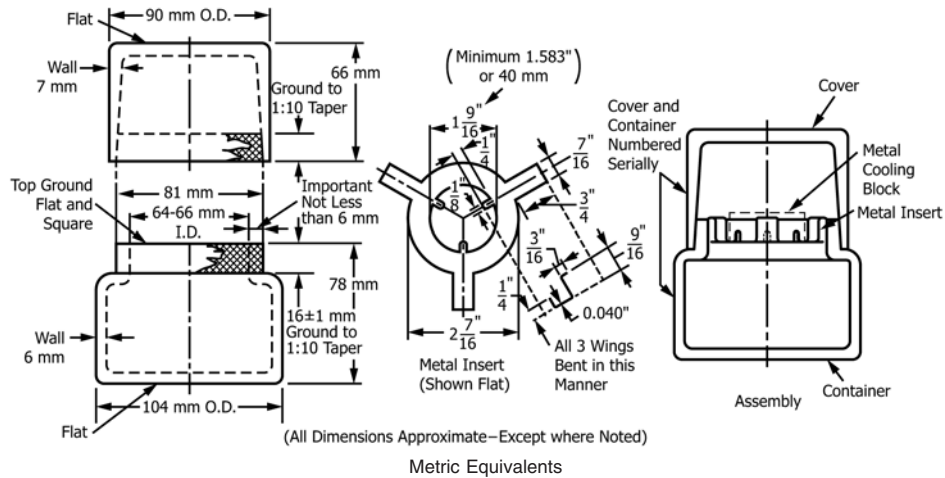

FIG. 25 Metal Crucible Container with Glass Cover



in.	0.040	1/8	3/16	1/4	7/16	9/16	3/4	27/16
mm.	11.0	3.2	4.8	6.4	11.1	14.3	19.1	61.9

FIG. 26 Glass Desiccator with Metal Insert

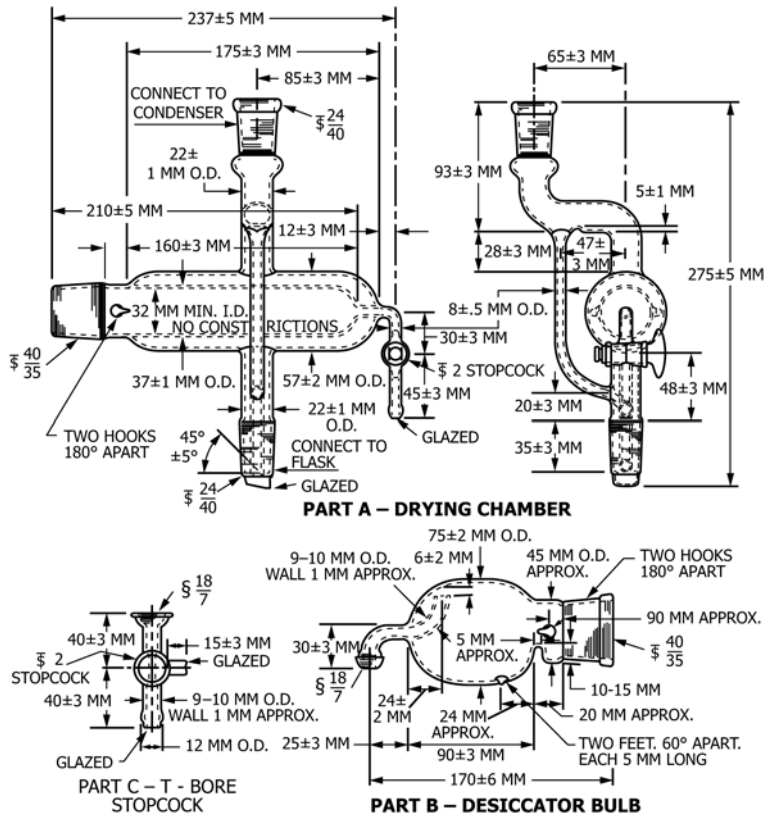



FIG. 27 Modified Aberdalden Drying Apparatus

 **E124 – 94 (2016)**

*ASTM International takes no position respecting the validity of any patent rights asserted in connection with any item mentioned in this standard. Users of this standard are expressly advised that determination of the validity of any such patent rights, and the risk of infringement of such rights, are entirely their own responsibility.*

*This standard is subject to revision at any time by the responsible technical committee and must be reviewed every five years and if not revised, either reapproved or withdrawn. Your comments are invited either for revision of this standard or for additional standards and should be addressed to ASTM International Headquarters. Your comments will receive careful consideration at a meeting of the responsible technical committee, which you may attend. If you feel that your comments have not received a fair hearing you should make your views known to the ASTM Committee on Standards, at the address shown below.*

*This standard is copyrighted by ASTM International, 100 Barr Harbor Drive, PO Box C700, West Conshohocken, PA 19428-2959, United States. Individual reprints (single or multiple copies) of this standard may be obtained by contacting ASTM at the above address or at 610-832-9585 (phone), 610-832-9555 (fax), or [service@astm.org](mailto:service@astm.org) (e-mail); or through the ASTM website ([www.astm.org](http://www.astm.org)). Permission rights to photocopy the standard may also be secured from the Copyright Clearance Center, 222 Rosewood Drive, Danvers, MA 01923, Tel: (978) 646-2600; <http://www.copyright.com/>*