



Standard Specification for Micro-Burets (Koch Style)¹

This standard is issued under the fixed designation E1189; the number immediately following the designation indicates the year of original adoption or, in the case of revision, the year of last revision. A number in parentheses indicates the year of last reapproval. A superscript epsilon (ϵ) indicates an editorial change since the last revision or reapproval.

1. Scope

1.1 This specification covers two styles of glass micro-burets of the “Koch” type for general laboratory use.

1.2 The values stated in SI units are to be regarded as standard. No other units of measurement are included in this standard.

2. Referenced Documents

2.1 ASTM Standards:²

- E438 Specification for Glasses in Laboratory Apparatus
- E675 Specification for Interchangeable Taper-Ground Stopcocks And Stoppers
- E676 Specification for Interchangeable Taper-Ground Joints
- E677 Specification for Interchangeable Spherical Ground Joints
- E694 Specification for Laboratory Glass Volumetric Apparatus
- E911 Specification for Glass Stopcocks with Polytetrafluoroethylene (PTFE) Plugs
- E920 Specification for Commercially Packaged Laboratory Apparatus
- E921 Specification for Export Packaged Laboratory Apparatus
- E1133 Practice for Performance Testing of Packaged Laboratory Apparatus for United States Government Procurements
- E1157 Specification for Sampling and Testing of Reusable Laboratory Glassware

¹ This specification is under the jurisdiction of Committee E41 on Laboratory Laboratory Apparatus and is the direct responsibility of Subcommittee E41.01 on Laboratory Ware and Supplies.

Current edition approved Sept. 1, 2016. Published September 2016. Originally approved in 1987. Last previous edition approved in 2010 as E1189 – 00 (2010). DOI: 10.1520/E1189-00R16.

² For referenced ASTM standards, visit the ASTM website, www.astm.org, or contact ASTM Customer Service at service@astm.org. For *Annual Book of ASTM Standards* volume information, refer to the standard’s Document Summary page on the ASTM website.

3. General Requirements

3.1 *Material*—Burets shall be made from Type I, Class A or B glass as specified in Specification E438.

3.2 *Stopcocks*—Both burets shall have permanently attached stopcocks with either glass plugs conforming to Specification E675 or PTFE plugs conforming to Specification E911.

3.3 *Joints and Stoppers*—All joints and stoppers shall comply with the requirements of Specifications E675, E676, or E677.

3.4 *Graduation*—The graduated section shall be in compliance with Pattern I of Specification E694.

4. Design

4.1 Style I:

4.1.1 Style I shall be in compliance with Table 1 and Fig. 1.

4.1.2 This style shall be equipped with a detachable tip with either a 7/25 joint or a SJ 12/5 joint.

4.1.3 Reservoir and graduated section shall be secured to each other to cushion against breakage during transit and in use. Typical arrangements are a cork spacer and tape or a glass bridge.

4.2 Style II:

4.2.1 Style II shall be in compliance with Table 2 and Fig. 2.

4.2.2 This style shall be equipped with a detachable tip of noble metals (platinum or platinum alloys) sealed to glass in a form commonly designated as Shohl-Type.

4.2.3 Reservoir section shall be separate from graduated section with connection made by a SJ 12/5 spherical ground joint complying with Specification E677.

5. Sampling and Testing

5.1 See Specification E1157.

6. Packaging

6.1 Select one from ASTM Standards: Specifications E920, E921, and Practice E1133.

7. Keywords

7.1 buret; glass; Koch; laboratory; micro

TABLE 1 Requirements For Style I

Capacity, mL	Scale Length, mm	Inside Diameter, mm	Outside Diameter, mm	Outflow Time, ^A seconds	Tolerance ±, mL
1.0 in 0.01	250 to 300	2.1 to 2.3	7.0 to 8.0	35 to 50	0.01
2.0 in 0.01	250 to 300	2.9 to 3.2	7.5 to 8.5	35 to 50	0.01
5.0 in 0.02	450 to 550	3.4 to 3.6	7.5 to 8.5	75 to 100	0.02
5.0 in 0.01	450 to 550	3.4 to 3.6	7.5 to 8.5	75 to 100	0.01
10.0 in 0.02	500 to 600	4.6 to 5.0	8.0 to 9.0	95 to 115	0.02

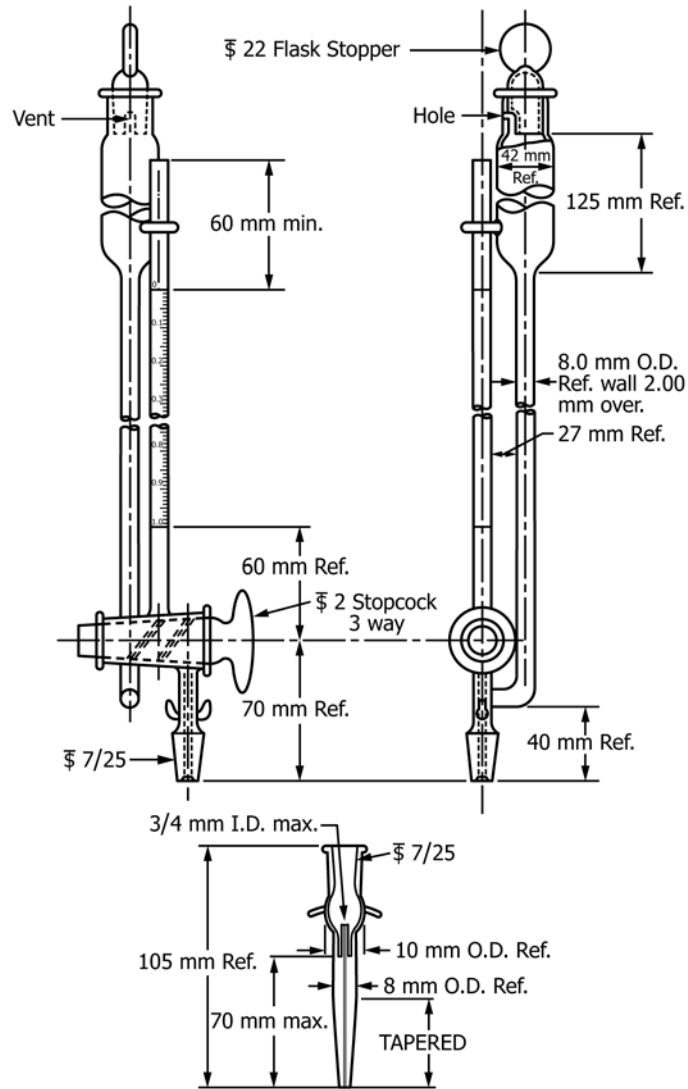

FIG. 1 Koch Burets, Style 1

TABLE 2 Requirements For Style II

Capacity, mL	Scale Length, mm	Inside Diameter, mm	Outside Diameter, mm	Outflow Time, ^A seconds	Tolerance ±, mL
1.0 in 0.01	135 to 150	2.9 to 3.2	7.0 to 8.0	25 to 35	0.01
2.0 in 0.01	250 to 300	2.9 to 3.2	7.0 to 8.0	45 to 75	0.01
5.0 in 0.01	450 to 550	3.4 to 3.6	7.5 to 8.5	105 to 140	0.01

^A The calibration tip shall deliver 100 to 110 drops per mL.

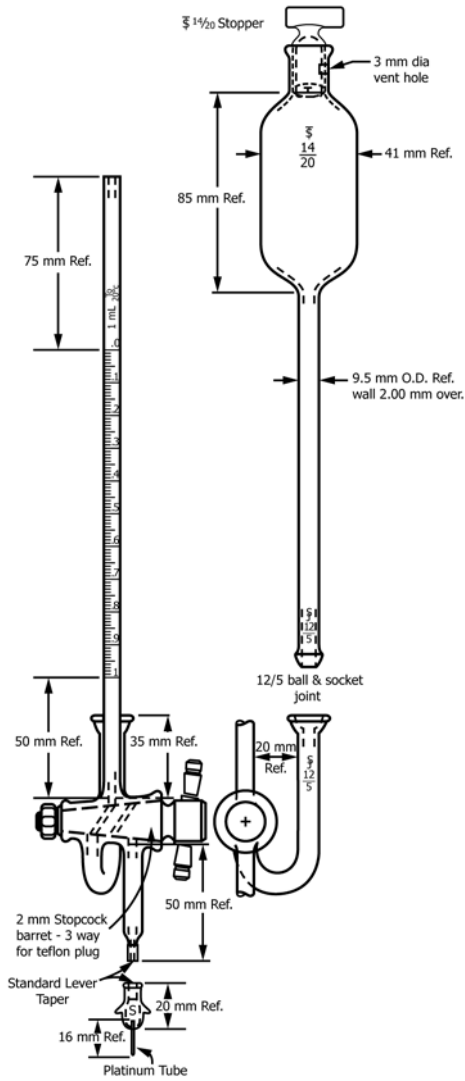

FIG. 2 Koch Burets, Style 2

ASTM International takes no position respecting the validity of any patent rights asserted in connection with any item mentioned in this standard. Users of this standard are expressly advised that determination of the validity of any such patent rights, and the risk of infringement of such rights, are entirely their own responsibility.

This standard is subject to revision at any time by the responsible technical committee and must be reviewed every five years and if not revised, either reapproved or withdrawn. Your comments are invited either for revision of this standard or for additional standards and should be addressed to ASTM International Headquarters. Your comments will receive careful consideration at a meeting of the responsible technical committee, which you may attend. If you feel that your comments have not received a fair hearing you should make your views known to the ASTM Committee on Standards, at the address shown below.

This standard is copyrighted by ASTM International, 100 Barr Harbor Drive, PO Box C700, West Conshohocken, PA 19428-2959, United States. Individual reprints (single or multiple copies) of this standard may be obtained by contacting ASTM at the above address or at 610-832-9585 (phone), 610-832-9555 (fax), or service@astm.org (e-mail); or through the ASTM website (www.astm.org). Permission rights to photocopy the standard may also be secured from the Copyright Clearance Center, 222 Rosewood Drive, Danvers, MA 01923, Tel: (978) 646-2600; http://www.copyright.com/