



Designation: E1106 – 12 (Reapproved 2017)

Standard Test Method for Primary Calibration of Acoustic Emission Sensors¹

This standard is issued under the fixed designation E1106; the number immediately following the designation indicates the year of original adoption or, in the case of revision, the year of last revision. A number in parentheses indicates the year of last reapproval. A superscript epsilon (ϵ) indicates an editorial change since the last revision or reapproval.

1. Scope

1.1 This test method covers the requirements for the absolute calibration of acoustic emission (AE) sensors. The calibration yields the frequency response of a transducer to waves, at a surface, of the type normally encountered in acoustic emission work. The transducer voltage response is determined at discrete frequency intervals of approximately 10 kHz up to 1 MHz. The input is a given well-established dynamic displacement normal to the mounting surface. The units of the calibration are output voltage per unit mechanical input (displacement, velocity, or acceleration).

1.2 *Units*—The values stated in SI units are to be regarded as standard. No other units of measurement are included in this standard.

1.3 *This standard does not purport to address all of the safety concerns, if any, associated with its use. It is the responsibility of the user of this standard to establish appropriate safety and health practices and determine the applicability of regulatory limitations prior to use.*

1.4 *This international standard was developed in accordance with internationally recognized principles on standardization established in the Decision on Principles for the Development of International Standards, Guides and Recommendations issued by the World Trade Organization Technical Barriers to Trade (TBT) Committee.*

2. Referenced Documents

2.1 *ASTM Standards:*²

[E114 Practice for Ultrasonic Pulse-Echo Straight-Beam Contact Testing](#)

[E494 Practice for Measuring Ultrasonic Velocity in Materials](#)

[E650 Guide for Mounting Piezoelectric Acoustic Emission Sensors](#)

¹ This test method is under the jurisdiction of ASTM Committee E07 on Nondestructive Testing and is the direct responsibility of Subcommittee E07.04 on Acoustic Emission Method.

Current edition approved June 1, 2017. Published July 2017. Originally approved in 1986. Last previous edition approved in 2012 as E1106 - 12. DOI: 10.1520/E1106-12R17.

² For referenced ASTM standards, visit the ASTM website, www.astm.org, or contact ASTM Customer Service at service@astm.org. For *Annual Book of ASTM Standards* volume information, refer to the standard's Document Summary page on the ASTM website.

E1316 Terminology for Nondestructive Examinations

3. Terminology

3.1 Refer to Terminology E1316 for terminology used in this test method.

4. Significance and Use

4.1 *Transfer Standards*—One purpose of this test method is for the direct calibration of displacement transducers for use as secondary standards for the calibration of AE sensors for use in nondestructive evaluation. For this purpose, the transfer standard should be high fidelity and very well behaved and understood. If this can be established, the stated accuracy should apply over the full frequency range up to 1 MHz.

NOTE 1—The stated accuracy applies only if the transfer standard returns to quiescence, following the transient input, before any wave reflected from the boundary of the calibration block returns to the transfer standard ($\sim 100 \mu\text{s}$). For low frequencies with periods on the order of the time window, this condition is problematical to prove.

4.2 *Applications Sensors*—This test method may also be used for the calibration of AE sensors for use in nondestructive evaluation. Some of these sensors are less well behaved than devices suitable for a transfer standard. The stated accuracy for such devices applies in the range of 100 kHz to 1 MHz and with less accuracy below 100 kHz.

5. General Requirements

5.1 A primary difficulty in any calibration of a mechanical/electrical transduction device is the determination of the mechanical-motion input to the device. To address this difficulty, this calibration procedure uses (i) a standard transducer whose absolute sensitivity is known from its design and physical characteristics; and also (ii) a source that produces motion that approximates a waveform calculable from theory. The use of two independent sources of information confers a degree of redundancy that is employed to confirm the validity of the measurements and quantify the experimental errors. Briefly stated, the sensitivity of the transfer standard (or other sensor under test) is determined by comparison with the standard transducer, while knowledge of a part of the theoretical waveform is used as a check.

5.2 *Test Block and Mechanical Input*—The mechanical input to the sensors is obtained by pressing a glass capillary

down onto the surface of a large test block until it breaks. The reasons for selecting this approach are: (a) capillary breaks are localized and short in duration, like natural acoustic emission events; and (b) use of a large block simplifies wave propagation and makes sensor output less dependent on arbitrary features of block geometry.

5.2.1 Prior to the fracture of the glass capillary, the force it exerts on the surface is distributed over an area on the order of 2 mm × 0.3 mm.³ When the glass capillary breaks, the force it was applying to the surface is abruptly relieved, within a time on the order of 0.2 to 0.3 μs. Within the limitations arising from these finite dimensions, the breaking of the capillary approximates a step force function at a point on the surface of the block. Theoretical solutions for the idealized response of a half-space to a normal point-force step function in time applied to the surface are available.^{4,5} The outputs of flat-response transducers have been found to be a good match (except for the infinite amplitude part) to the theoretical waveforms, supporting the use of this theory as a check on the primary calibration of sensors. An example with a flat response transducer is shown in Figure 9. The vertical component of the theoretical waveform comprises three parts: (a) a low-amplitude response beginning at time d/c_L , where d is the distance from the source and c_L is the longitudinal wave velocity; (b) a short impulsive response between times d/c_S and d/c_R , where c_S is the shear wave velocity and c_R the Rayleigh wave velocity; (c) a step function beginning at d/c_R . It is the last of these that is salient for checking the sensor calibration. The theoretical height⁶ (shelf value [see Figure 9 for determination of the shelf value], relative to zero displacement) of this displacement step u_3 is:

$$u_3 = F_0 A / 4\pi\mu d (A - 1)$$

where F_0 is the applied force (which is measured), μ is the shear modulus (calculated by use of the shear wave velocity) of the test block, $A = (c_L/c_S)^2$ and d is the distance from the source to the transducer.

5.3 *Absolute Displacement Measurement*—An absolute measurement of the dynamic normal surface displacement of the block is required for this calibration test method. The transducer used for this measurement is a standard transducer against which the device under test is compared. The standard transducer should meet or exceed the performance of the capacitive transducer described by Breckenridge and Greenspan.⁷ The important characteristics of the standard transducer include high fidelity, high sensitivity, and operating character-

istics amenable to theoretical calculation. It should also present no appreciable dynamic loading to the surface it is measuring.

5.3.1 For a calibration, the standard transducer and the device to be calibrated are both placed on the same surface of the block as the mechanical input and equidistant in opposite directions from it. This guarantees that both experience the same displacement-time history. Comparison of the output of the transfer standard or AE sensor with the output of the standard transducer yields a calibration of the device under test.

5.3.2 Other relative geometries for the input and transducers are possible, but results from other geometries should only be used to supplement results from the “same surface” geometry. AE waves in structures are most frequently dominated by surface wave phenomena, and the calibration should be based on the transducer’s response to such waves.

5.4 *Units for the Calibration*—An AE sensor may be considered to respond to either stress or strain at its front face. The actual stress and strain at the front face of a mounted sensor depend on the interaction between the mechanical impedance of the sensor (load) and that of the mounting block (driver). Neither the stress nor the strain is amenable to direct measurement at this location. However, the free displacement that would occur at the surface of the block in the absence of the sensor can be inferred from measurements made elsewhere on the surface. Also, the ideal displacement (except at the point where the displacement becomes infinite) for an ideal source is known from theory. Since AE sensors are used to monitor motion at a free surface of a structure and interactive effects between sensor and structure are generally of no interest, the free surface motion is the appropriate input variable. It is, therefore, recommended that the units of calibration should be voltage per unit of free motion; for example, volts per metre.

5.5 *Block Material:*

5.5.1 Since the calibration depends on the interaction of the mechanical impedance of the block and that of the AE sensor, a calibration procedure must specify the material of the block. Calibrations performed on blocks of different materials will yield transducer sensitivity versus frequency curves that are different in shape and in average magnitude. The amount by which such averages differ may be very large. A transducer calibrated on a glass or aluminum block will have an average sensitivity that may be from 50 to 100 % of the value obtained on steel, and will have an average sensitivity that may be as little as 3 % of the value obtained on steel if calibrated on a polymethyl methacrylate block. In general, the sensitivity will be less if the block is made of a less rigid or less dense material.

5.5.2 The Rayleigh speed in the material of the block affects surface wave calibrations. For a sensor having a circular aperture (mounting face) with uniform sensitivity over the face, the aperture effect predicts nulls at the zeroes of $J_1(ka)$, where $k = 2\pi f/c_R$, and f = frequency, c_R = Rayleigh speed, and a = radius of the sensor face (active element). Hence, the frequencies at which the nulls occur are dependent upon the Rayleigh speed.

³ Burks, Brian, “Re-Examination of NIST Acoustic Emission Sensor Calibration: Part I – Modeling the Loading from Glass Capillary Fracture,” *Journal of Acoustic Emission*, Vol. 29, pp. 167–174.

⁴ Breckenridge, F. R., “Acoustic Emission Transducer Calibration by Means of the Seismic Surface Pulse,” *Journal of Acoustic Emission* Vol 1, pp. 87–94.

⁵ Hsu, N. N., and Breckenridge, F. R., “Characterization and Calibration of Acoustic Emission Sensors,” *Materials Evaluation*, Vol 39, 1981, pp. 60–68.

⁶ Paul G. Richards, “Elementary Solutions to Lamb’s Problem for a Point Source and their Relevance to Three- Dimensional Studies of Spontaneous Crack Propagation,” *Bull. of the Seismological Society of America*, Vol 69, No. 4, 1979, pp. 947–956.

⁷ Breckenridge, F. R., and Greenspan, M., “Surface-Wave Displacement: Absolute Measurements Using a Capacitive Transducer,” *Journal, Acoustic Society of America*, Vol 69, pp 1177–1185.

6. Apparatus

6.1 A typical basic scheme for the calibration is shown in Fig. 1. A glass capillary, *B*, of diameter about 0.2 mm, is squeezed between the tip of the loading screw, *C*, and the upper face of the large steel transfer block, *A*. When the capillary breaks, the sudden release of force is nearly a step function whose risetime is of the order of 0.2 μs to 0.3 μs. The magnitude of the force step is measured by the combination of the PZT disc, *D*, in the loading screw and a charge amplifier, *E*, connected to a waveform recorder, *F*. Alternatively, the force step can be measured by a strain-gage load cell within the loading screw with standard electronic conditioning for the strain gages. The standard capacitive transducer, *G*, and the device under test, *H*, are placed equally distant (usually 100 mm) from the source and in opposite directions from it. It is obvious from the symmetry that the surface displacements would be the same at the two transducer locations if it were not for the loading effects of the transducers. The loading effect of the standard capacitive transducer is negligible and the loading effect of the unknown sensor is part of its calibration.

6.1.1 Voltage transients from the two transducers are recorded simultaneously by digital recorders, *I*, and the information is stored for processing by the computer, *J*.

6.1.2 With such a system, it is possible to do the necessary comparison between the signal from the unknown sensor and that from the standard transducer.

6.1.3 As a check, the shelf value (see section 5.2.1) determined from the standard transducer output is compared with the value determined from the measured capillary break force using the equation in 5.2.1. This comparison should provide supporting evidence that the precision stated in 8.5 has been attained. This check should be made at least one time for each calibration performed.

6.2 *The Transfer Block*—The transfer block must be made from specially chosen material. It should be as defect-free as possible and should undergo an ultrasonic longitudinal examination at 2.25 MHz. The method described in Practice E114 should be used. The block should contain no flaws which give a reflection larger than 10 % of the first back wall reflection. The material should also be highly uniform as determined by pulse-echo time of flight measurements through the block at a minimum of 15 locations regularly spaced over the surface (see Practice E494). The individual values of the longitudinal and shear wave speed should differ from the average by no more than ±1 part and ±3 parts in 10⁴, respectively. A transfer block and calibration apparatus is shown in Fig. 2.

6.3 *The Source*—The source events, which are a useful approximation to force step functions, are to be made by breaking glass capillary tubing (Fig. 3). The capillaries are drawn down from ordinary laboratory glass tubing made of borosilicate glass. Sizes of the capillary may range from about

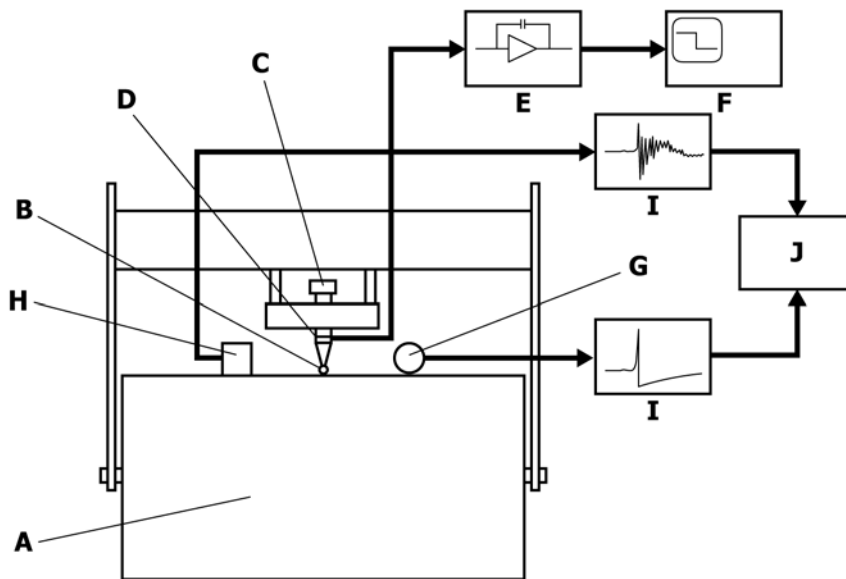

- A—steel transfer block
- B—capillary source
- C—loading screw
- D—PZT disc or strain-gage load cell
- E—charge amplifier or strain gage conditioning electronics
- F—transient recorder
- G—standard transducer
- H—transducer under test
- I—transient recorders
- J—computer

FIG. 1 Schematic Diagram of the Apparatus

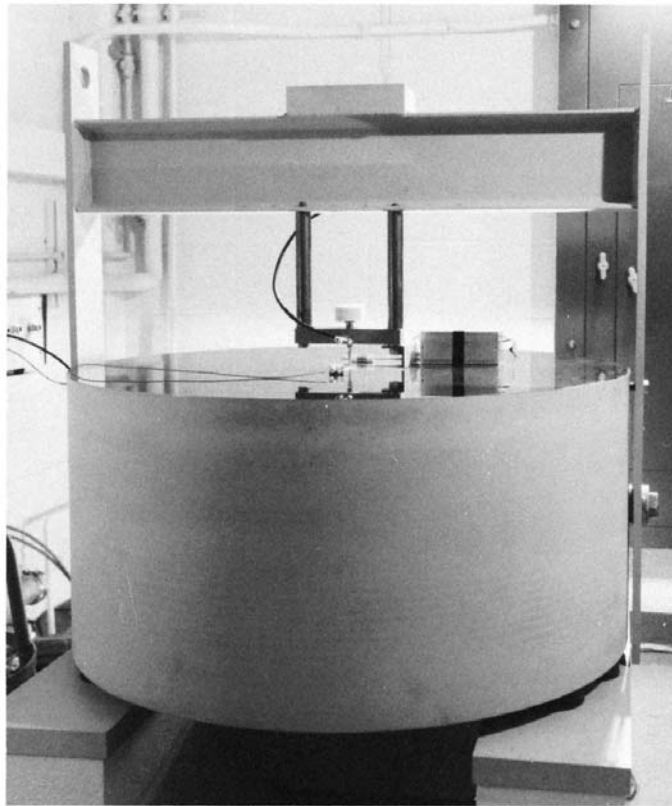

FIG. 2 Photograph of the Steel Block with the Calibration Apparatus in Place

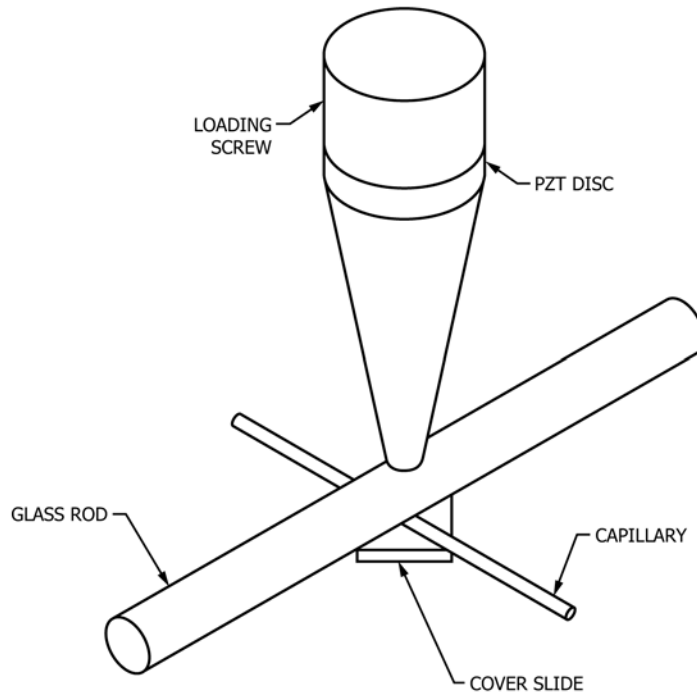

FIG. 3 Glass Capillary Source

0.1 mm to 0.3 mm outside diameter, with 0.2 mm being typical. A bore size equal to the wall thickness gives the best results. The force obtained is usually between 10 N and 20 N.

6.3.1 The capillary is to be laid horizontally (perpendicular to the propagation direction to the transducers) on a piece of microscope cover glass (0.08 mm by 1.5 mm by 1.5 mm)

which has been cemented to the top face of the steel block with salol (phenyl salicylate) or cyanoacrylate cement. The force is applied to the capillary by a solid glass rod (2 mm in diameter) which has been laid horizontally on top of the capillary and at right angles to it. The rod is forced downward by the loading screw until the capillary breaks. The loading screw is to be threaded through a yoke above the calibration surface. The loading screw should contain a ceramic force transducer or a strain-gage based load cell, which has been calibrated by dead weights. Thus, although the size of a source event cannot be predicted in advance, its magnitude may be measured and used for the elasticity theory calculation of the surface displacement as given in section 5.2.1.

6.3.2 Ideally, the capillary should rest directly on the steel with no cover glass interposed. It may be found necessary to use the cover slide to prevent damage to the block surface. The presence of the cover glass does alter the waveform very slightly; a slight ringing occurs due to reflections at its boundaries. The ringing contains only frequencies above 2 MHz. Furthermore, the effects on both standard transducer and unknown sensor are the same; therefore, the calibration is not affected.

6.4 *The Standard Transducer*—The standard transducer to be used for the absolute measurement of displacement in the calibration is to have characteristics at least as good as the capacitive transducer described by Breckenridge and Greenspan.⁷ This device, shown in Figs. 4 and 5, essentially consists of an inertial mass (about 40 g) mounted on compliant supports and separated from the top surface of the steel block by an air gap of about 4 μm. This gap is determined by measuring the capacitance between the transducer and the transfer block using a three-terminal ratio arm bridge as described by

Breckenridge and Greenspan⁷ or an alternate technique with similar accuracy. The inertial mass is a brass cylinder with its axis horizontal. When the block surface moves at frequencies above the natural resonance of the mass on its compliant supports (approximately 1 kHz), the brass cylinder remains approximately stationary. The brass cylinder is polarized to 100.00 Vdc through a large valued resistor. The large resistance causes the capacitor to operate essentially in a fixed charge condition so that the voltage varies inversely with capacitance for the frequencies of interest.

6.4.1 For use as a primary standard, it is essential that the sensitivity of the transducer be calculable. To make the calculations tractable, the cylinder is treated as a section of an infinite cylinder. Electrical guards are attached to each end to eliminate end effects that would otherwise be severe.

6.4.2 The sensing area of the transducer is 12.4 mm long and effectively less than 1 mm wide. The long axis of this area is tangent to an advancing wavefront from the capillary source.

6.4.3 The sensitivity of the transducer is approximately 12×10^6 V/m and the minimum detectable rms displacement is 4×10^{-12} m. The calculated frequency response of the transducer based on its effective aperture width and its deviation from the curvature of the wavefronts is shown in Fig. 6. At 1 MHz the amplitude is down by less than 10 % and the phase lag is about 8°. Expressions in Breckenridge and Greenspan⁷ can be used to calculate the response at frequencies of interest. The total estimated uncertainty in the displacement measurements is approximately ±5 %. Displacement measurements made by the transducer are in agreement with displacements calculated by elasticity theory within 5 %. See Breckenridge and Greenspan.⁷

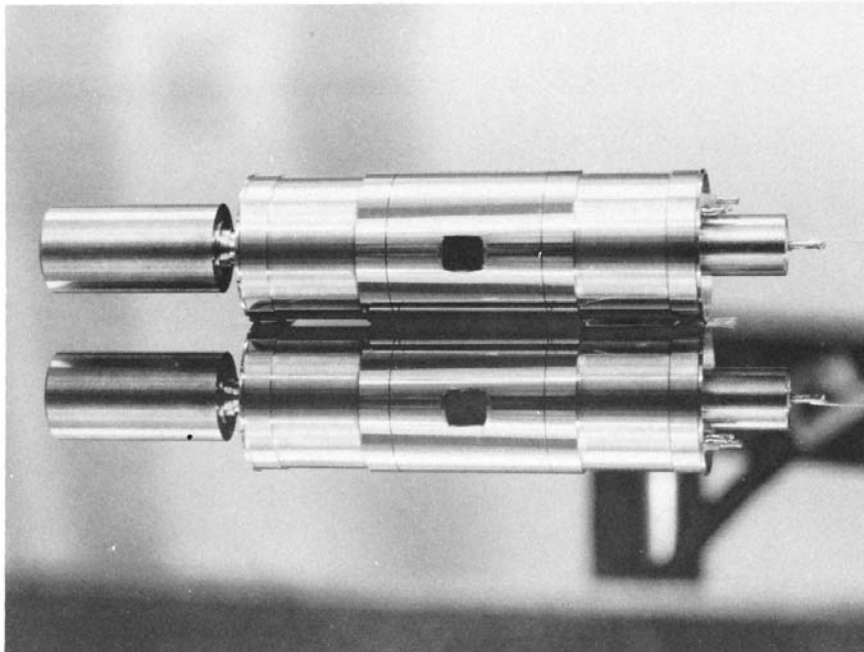
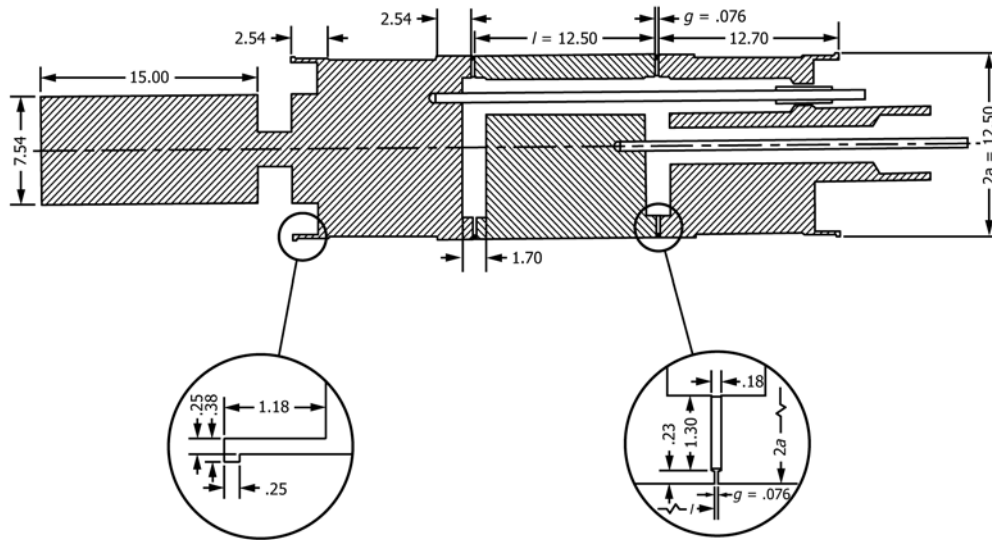

FIG. 4 Photograph of the Capacitive Transducer and its Reflection in the Steel Block



NOTE 1—All dimensions are given in millimetres. Here l is the length of the active electrode, $2a$ is its diameter, and g is the width of the guard gap.
FIG. 5 Longitudinal Section Through the Transducer

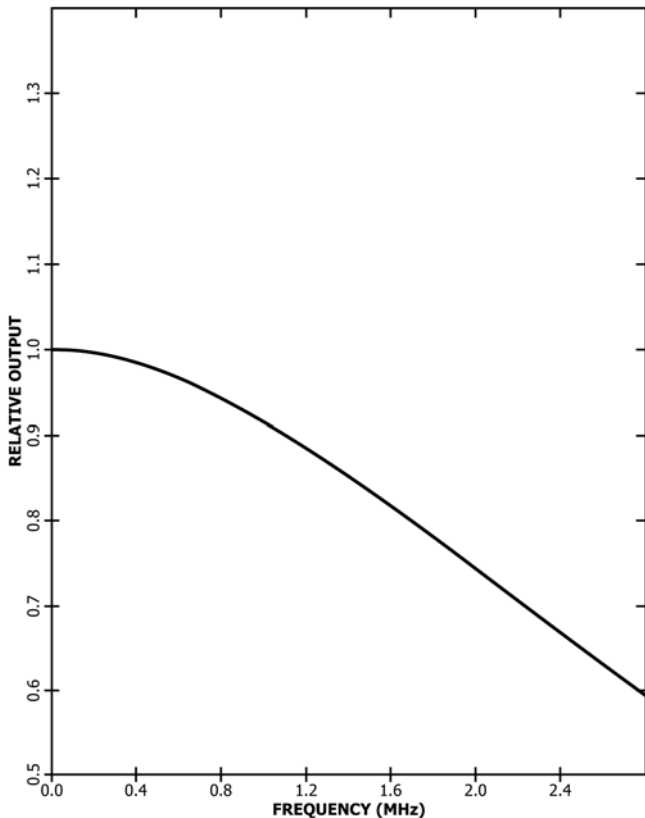

FIG. 6 The Calculated Frequency Response of the Capacitive Transducer Based on its Effective Aperture Width and the Deviation of the Straight Aperture Slot from the Circular Wavefront at 0.1 m from the Source

essary for capturing the waveforms from the standard transducer and the transducer under test. They should be capable of at least 12 bit accuracy and a sampling rate of at least 20 MHz and should be capable of recording for at least 102.4 μ s. The data so recorded should be transferred to a computer for data processing and should also be stored on a permanent device such as a compact disc for a permanent record.

7. Procedure

7.1 The following notation is used to describe the treatment of data to obtain calibration results.

- n = total number of samples in one channel,
- Δt = sampling time interval in μ s,
- T = $n\Delta t$ = total record time in μ s,
- s_j = the j th sample value in the standard channel,
- u_j = the j th sample value in the unknown channel,
- j = 0, 1, 2, ..., $n - 1$.

The units of s_j and u_j are volts multiplied by an arbitrary constant which depends on the specific electronic equipment configuration.

7.2 The complex valued spectra $S(f_m)$ and $U(f_m)$ of the standard and unknown are defined by:

$$S(f_m) = \Delta t \sum_{j=0}^{n-1} s_j \exp(i2\pi mj/n) \quad (1)$$

$$U(f_m) = \Delta t \sum_{j=0}^{n-1} u_j \exp(i2\pi mj/n) \quad (2)$$

where:
 $f_m = m/T$, $m = 0, 1, 2, \dots, n/2 - 1$, is the m th frequency in MHz. Treat the data by using a fast Fourier transform to determine the values of the spectra $S(f_m)$ and $U(f_m)$. The response of the transducer under test, $D(f_m)$, with respect to that of the standard transducer, is as follows:

$$D(f_m) = \frac{U(f_m)}{S(f_m)}$$

6.4.4 The standard transducer and the device under test are to be placed 100 ± 1 mm from the source unless otherwise stated in each report of calibration results.

6.5 **Data Recording and Processing Equipment**—Two synchronized channels of transient recording equipment are nec-

7.3 Calculate the magnitude and phase from $U(f_m)$, $S(f_m)$, and $D(f_m)$ in the usual way; for example,

$$r_m = \text{magnitude of } D(f_m) = |D(f_m)|$$

$$\theta_m = \text{phase of } D(f_m) = -\text{actan} \frac{I[D(f_m)]}{R[D(f_m)]}$$

7.4 Graphical representation of the foregoing steps in a typical calibration is given in Section 9. In absolute units, the sensitivity of the unknown transducer is $A r_m$, where A is the absolute sensitivity of the standard transducer.

7.5 Several aspects of the calculations require special attention.

7.5.1 The spectrum from the standard transducer should be corrected for the previously mentioned aperture and wavefront curvature effects (Fig. 6).

7.5.2 A problem arises in doing a discrete Fourier transform on a function of finite length if the initial and final values of the function are unequal. The transform treats the function as though it were periodic with period equal to the length of the time recorded. If initial and final values are unequal, then artificial steps are introduced at the time when each successive period joins the next. The result is the introduction of spurious frequencies in the transform. A simple solution to this problem is to add a linear function to the data as follows:

$$s'_j = s_j + (j/n)(s_0 - s_{n-1})$$

$$u'_j = u_j + (j/n)(u_0 - u_{n-1})$$

The modified functions s'_j and u'_j introduce no artificial steps. It has been shown analytically that this procedure and two other commonly used techniques for dealing with step-like functions are all equivalent at frequencies other than zero.⁸

7.5.3 In the calculation of phase, a four-quadrant routine is used which finds that value of $-\arg(D(f_m))$ which lies between $-\pi$ and π .

7.5.4 Since phase is defined as the argument of a complex number, it is uniquely determined only to within multiples of 2π . The phase is that value of $-\arg(D(f_m))$, say, which lies between $-\pi$ and π . This means that if, as frequency increases, $D(f_m)$ should cross the negative real axis, then the phase would jump by 2π . To eliminate these jumps, a routine should be adopted which calculates phases in sequence of increasing frequency such that each phase value is the nearest one to the preceding one. For transducers with well-behaved phase characteristics, this routine works well. Sometimes, however, in the case of a transducer with a wildly oscillating phase characteristic or a response which goes very near zero at some frequency, a phase ambiguity of $\pm 2n\pi$ exists.

7.5.5 Various alternatives exist for the expression of the calibration data. In the above-described form, the unit of magnitude is volts of output per metre of surface displacement. This is true because the standard transducer is a displacement sensor. One alternative is to convert the response to volts per unit velocity (Vs/m). This is done by multiplying the values of $S(f_m)$ from the standard transducer by $2\pi f_m$, which is equivalent to differentiation of the original time function.

7.5.6 Conversion of the unknown transducer's frequency response to a time domain waveform, or impulse response, can also be done by means of an inverse discrete Fourier transform. The impulse response of the unknown device can also be calculated directly by deconvolution of the unknown device's time waveform by that of the standard transducer. Such impulse response information may be provided in addition to the frequency response information.

7.5.7 Each and every primary calibration will include a comparison between the theoretical result (using the measured force in the equation in section 5.2.1) and capacitive sensor output (converted to a displacement result), as regards the shelf displacement. If they differ by 6 % or less, that primary calibration operation was successful, and the result based on the capacitive sensor will be reported. If they differ by more than 6 %, the two systems will be recalibrated/re-measured to resolve the difference (to bring them into agreement by less than 6 %).

8. Precision and Bias

8.1 There are several sources of error that affect the accuracy and repeatability of this test method of calibration. These include the capture process, and variability in the mounting of the sensor under test.

8.2 The absolute sensitivity of the capacitive transducer described in 5.3 is known within ± 5 %, and so the calibration scale factor is uncertain by this amount. The shape of the calibration curve is not affected.

8.3 There are expected errors in the calibration arising from sources including amplifier noise and quantization noise in the signal capture, some randomness in the source, and the discrete approximation to the continuous Fourier transform. These errors are difficult to assess, but should be evaluated experimentally by repeated calibration of a transducer without remounting in between.

8.3.1 There are also expected errors arising from the fact that data are captured during a finite interval of time (102.4 μ s), and any signals from the transducer after this interval are ignored. For transducers which have short ring-down times, this error is expected to be negligible; but to the extent to which there is any ringing in progress at the end of the interval, then there will be significant errors.

8.3.2 The Fourier transform yields discrete frequency components separated by $1/T$, or approximately 10 kHz, which is an approximation to the true, continuous frequency spectrum. At frequencies below 100 kHz, this scale becomes rather coarse. For transducers that are high fidelity and well behaved, there is meaningful information at the frequencies between 10 kHz and 100 kHz. For resonant transducers, it is difficult to establish an expected accuracy in this range. At frequencies above 1 MHz, the amplifier noise and quantization noise become so severe that the expected accuracy statements do not apply. At frequencies between 0.1 and 1.0 MHz, the expected errors attributable to amplifier noise, quantization noise, finiteness of the Fourier transform, and the finiteness of the time window should be ± 5 % with a confidence of 90 %. For near ideal transducers, this error estimate can be extended to 0.01 to 1.0 MHz.

⁸ Waldmeyer, J., "Fast Fourier Transform for Step-Like Functions: The Synthesis of Three Apparently Different Methods," *IEEE Transactions on Instrumentation and Measurement*, Vol. im-29, no. 1, 1980, pp. 36–39.

8.4 The repeatability between calibrations of a transducer after remounting is poorer than without remounting. Making a repeatable mechanical coupling of a transducer to a surface is known to be a problem (see also Guide E650). In this calibration, special attention must be used to minimize variability due to the following: lack of flatness of the mounting face of the sensor, the presence of small burrs on the surface of the transfer block, dirt in the couplant layer, excessive viscosity of the couplant, and variability in the amount or point of application of the holddown force on the transducer being calibrated (9.8 N, centered, is recommended). Control of these conditions should be verified by repeatedly recalibrating a transducer after remounting. The agreement between different calibrations of the same device should be within $\pm 10\%$ of the maximum value of A_{r_m} over the range of 0.1 to 1.0 MHz with a confidence of 90 %.

8.5 Data from repeated calibrations should be collected and the overall system verified to produce a calibration precision of $\pm 15\%$.

9. Typical Calibration Results

9.1 Figs. 7 and 8 show typical results from two calibrations of an AE transducer that has been remounted in between.

9.2 Figs. 9-16 illustrate the steps in the processing of the calibration data from an AE transducer.

9.3 At the least, figures similar to Fig. 9, Fig. 10, Fig. 15, and Fig. 16 should be included in a report of calibration along with reference to the basic method and any differences from expected procedure.

10. Keywords

10.1 absolute calibration; acoustic emission sensor; breaking capillary; capacitive transducer; nondestructive testing; surface wave; transfer standard

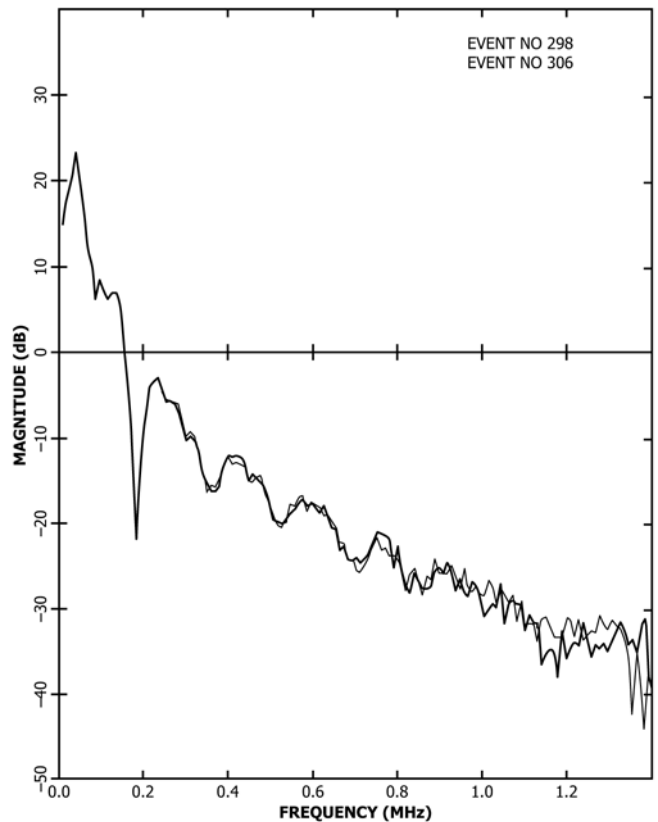

FIG. 7 Magnitude Responses of an AE Transducer as Determined by Two Calibrations with Remounting of the Transducer In Between

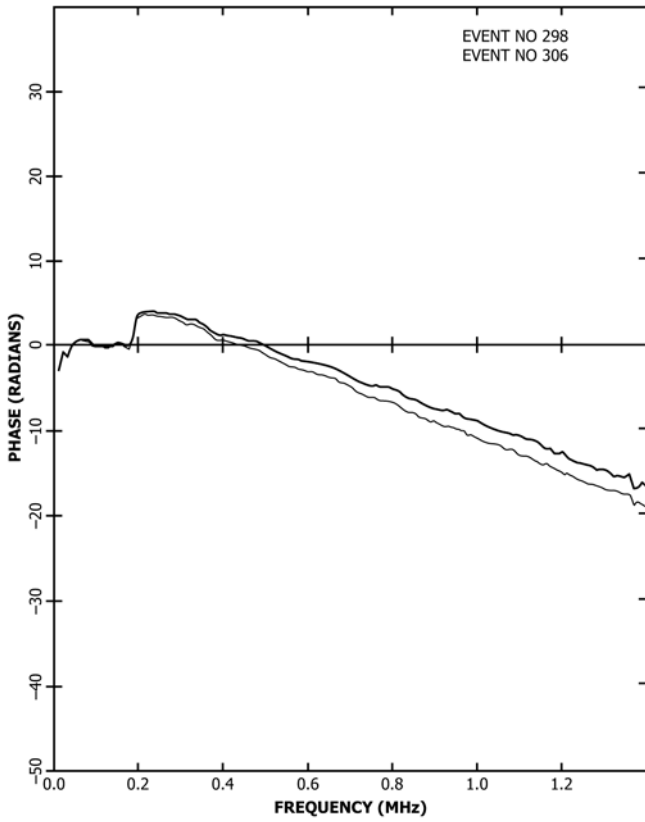

FIG. 8 Phase Responses Corresponding to the Magnitude Responses of Fig. 7

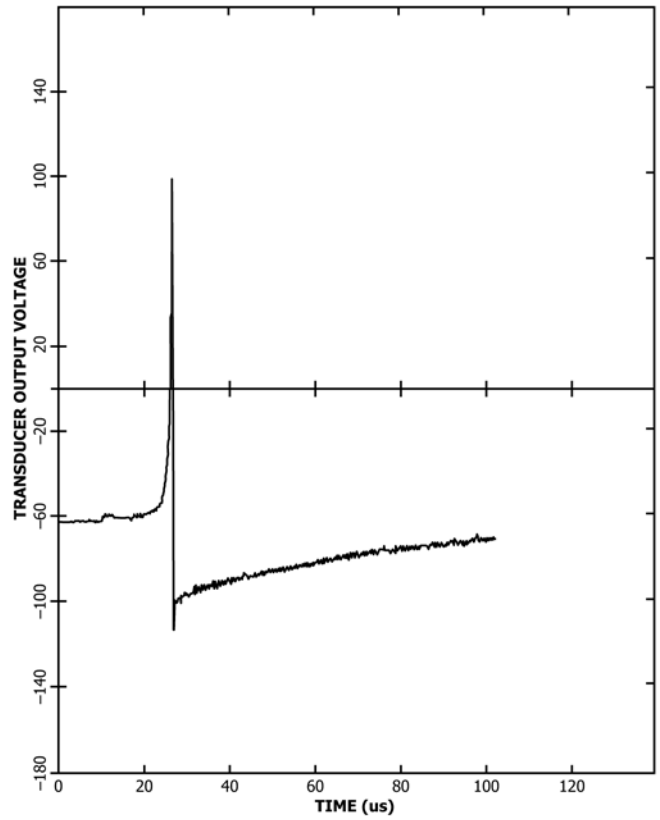

FIG. 9 A Typical Calibration—Voltage Versus Time Waveform from the Standard Transducer as Captured by the Transient Recorder (Note that the “shelf” value for the elasticity calculation of section 5.2.1 is located just after the negative going “overshoot”)

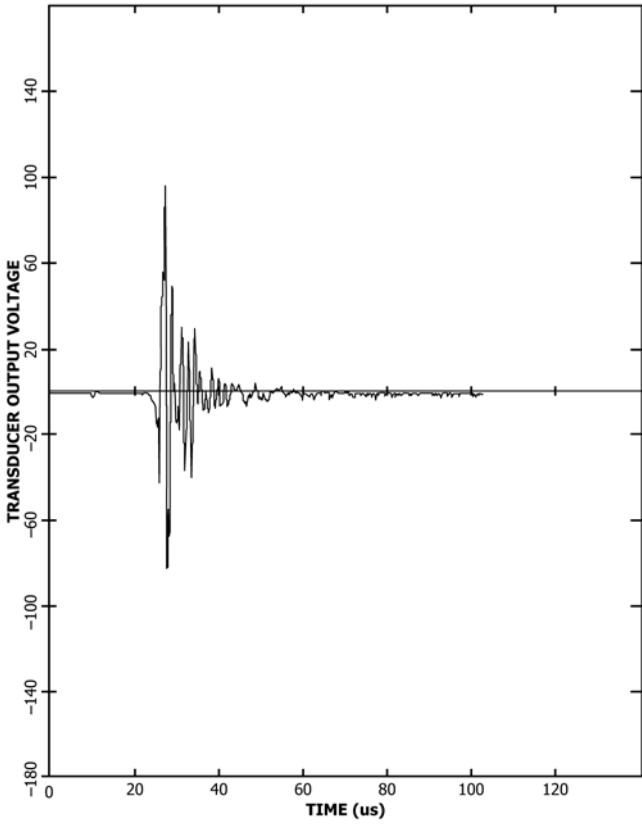

FIG. 10 The Same Calibration—Voltage Versus Time Waveform from the Unknown Transducer as Captured by the Transient Recorder

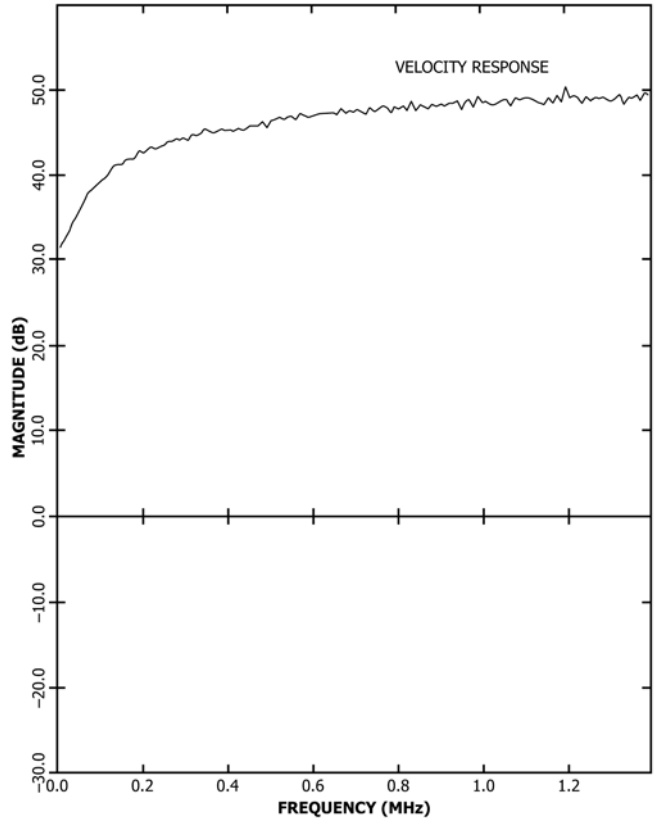

FIG. 11 Spectrum Magnitude as Obtained by Performing a Fast Fourier Transform on the Data of Fig. 9

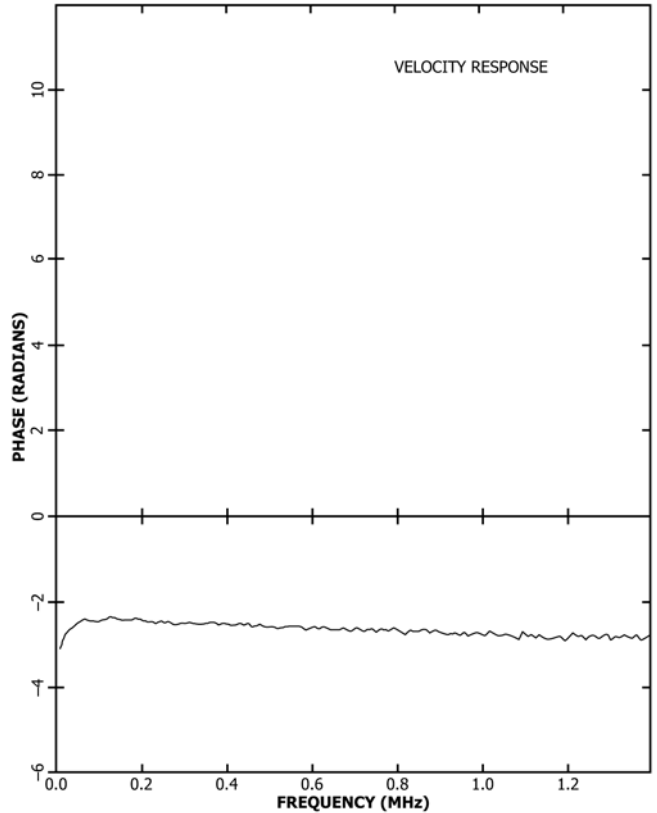

FIG. 12 Spectrum Phase Corresponding to the Spectrum Magnitude of Fig. 11

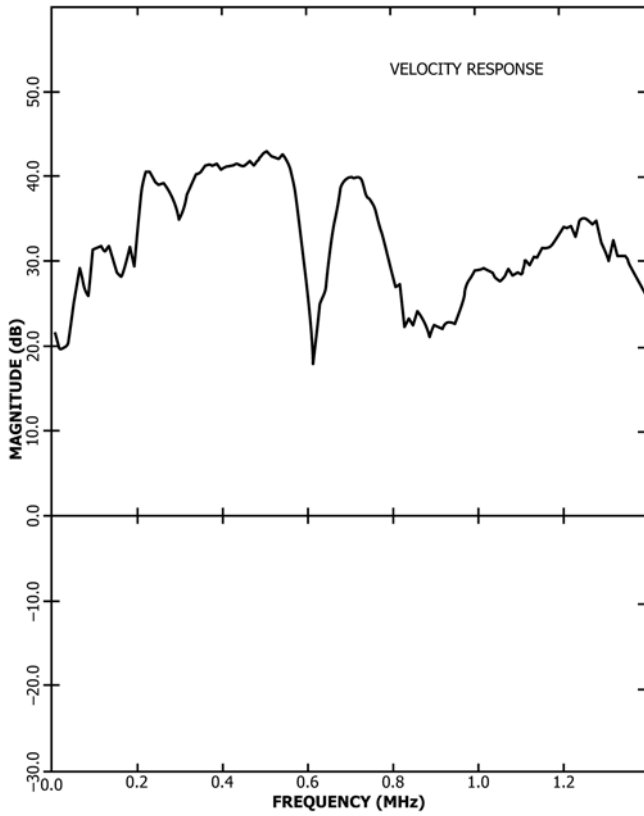

FIG. 13 Spectrum Magnitude as Obtained by Performing a Fast Fourier Transform on the Data of Fig. 10

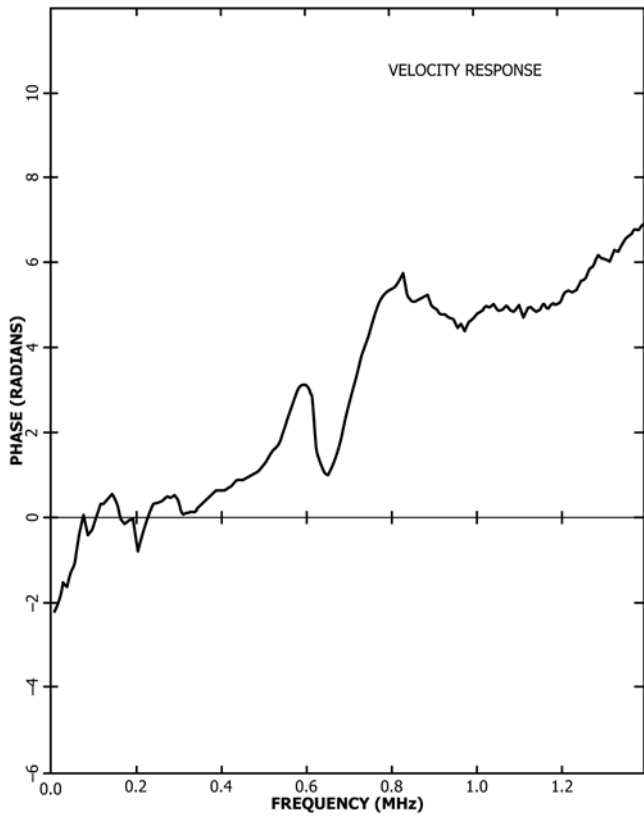

FIG. 14 Spectrum Phase-Corresponding to the Spectrum Magnitude of Fig. 13

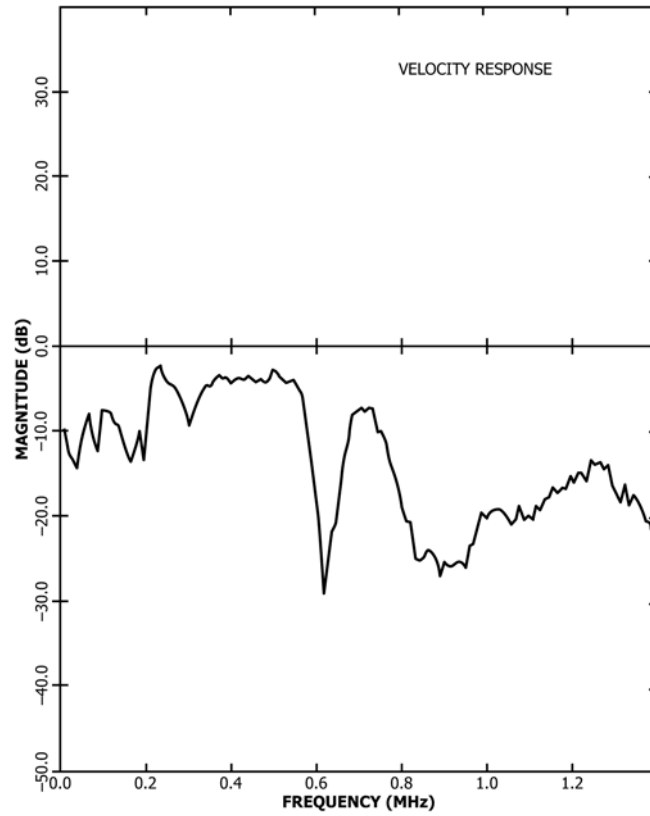

FIG. 15 Magnitude Response of the Unknown Transducer as Obtained by Division of the Ordinates of Fig. 13 by Those of Fig. 11

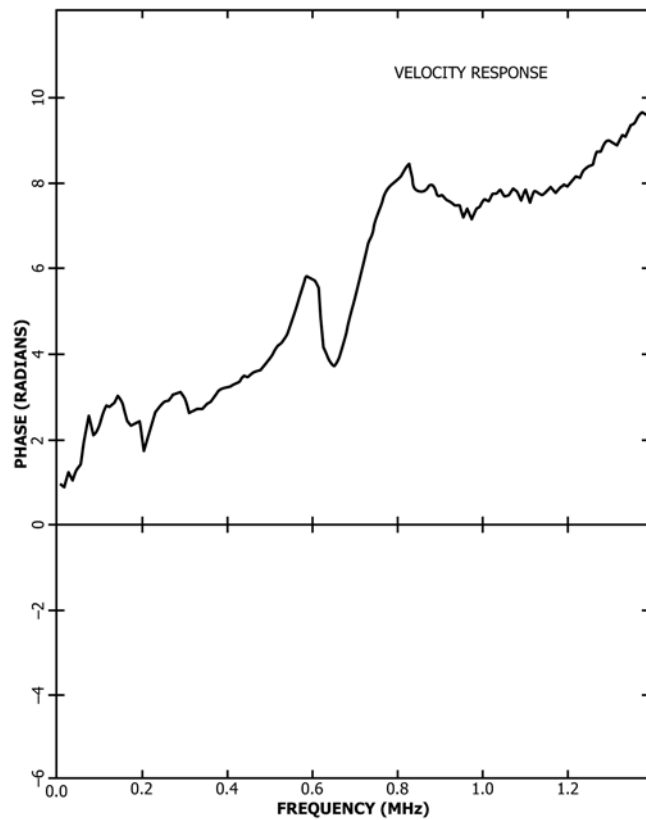



FIG. 16 Phase Response of the Unknown Transducer as Obtained by Subtracting the Ordinates of Fig. 12 from Those of Fig. 14

 **E1106 – 12 (2017)**

ASTM International takes no position respecting the validity of any patent rights asserted in connection with any item mentioned in this standard. Users of this standard are expressly advised that determination of the validity of any such patent rights, and the risk of infringement of such rights, are entirely their own responsibility.

This standard is subject to revision at any time by the responsible technical committee and must be reviewed every five years and if not revised, either reapproved or withdrawn. Your comments are invited either for revision of this standard or for additional standards and should be addressed to ASTM International Headquarters. Your comments will receive careful consideration at a meeting of the responsible technical committee, which you may attend. If you feel that your comments have not received a fair hearing you should make your views known to the ASTM Committee on Standards, at the address shown below.

This standard is copyrighted by ASTM International, 100 Barr Harbor Drive, PO Box C700, West Conshohocken, PA 19428-2959, United States. Individual reprints (single or multiple copies) of this standard may be obtained by contacting ASTM at the above address or at 610-832-9585 (phone), 610-832-9555 (fax), or service@astm.org (e-mail); or through the ASTM website (www.astm.org). Permission rights to photocopy the standard may also be secured from the Copyright Clearance Center, 222 Rosewood Drive, Danvers, MA 01923, Tel: (978) 646-2600; <http://www.copyright.com/>