



Standard Test Method for Testing Polymeric Seal Materials for Geothermal or High Temperature Service, or both, Under Sealing Stress¹

This standard is issued under the fixed designation E1069; the number immediately following the designation indicates the year of original adoption or, in the case of revision, the year of last revision. A number in parentheses indicates the year of last reapproval. A superscript epsilon (ϵ) indicates an editorial change since the last revision or reapproval.

1. Scope

1.1 This test method covers the initial evaluation of (screening) polymeric materials for seals under static sealing stress and at elevated temperatures.

1.2 This test method applies to geothermal service only if used in conjunction with Test Method E1068.

1.3 The test fluid is distilled water.

1.4 The values stated in SI units are to be regarded as the standard. The values in parentheses are for information only.

1.5 *This standard does not purport to address all of the safety concerns, if any, associated with its use. It is the responsibility of the user of this standard to establish appropriate safety and health practices and determine the applicability of regulatory limitations prior to use.*

2. Referenced Documents

2.1 *ASTM Standards:*²

D1414 Test Methods for Rubber O-Rings

E1068 Test Method for Testing Nonmetallic Seal Materials by Immersion in a Simulated Geothermal Test Fluid

2.2 *SAE Standard:*

ANSI/SAE AS568A Aerospace Size Standard for O-Rings³

3. Summary of Test Method

3.1 Standard O-ring specimens are tested in a test fixture that has a closely controlled extrusion gap.

3.2 Temperature is applied to the test fixture, with test specimens, and then pressure is applied.

3.3 The test fluid is distilled water.

¹ This test method is under the jurisdiction of ASTM Committee E44 on Solar, Geothermal and Other Alternative Energy Sources and is the direct responsibility of Subcommittee E44.15 on Geothermal Field Development, Utilization and Materials.

Current edition approved April 1, 2009. Published June 2009. Originally approved in 1985. Last previous edition approved in 2003 as E1175–85(2003). DOI: 10.1520/E1069-85R09.

² For referenced ASTM standards, visit the ASTM website, www.astm.org, or contact ASTM Customer Service at service@astm.org. For *Annual Book of ASTM Standards* volume information, refer to the standard's Document Summary page on the ASTM website.

³ Available from Society of Automotive Engineers (SAE), 400 Commonwealth Dr., Warrendale, PA 15096-0001, http://www.sae.org.

3.4 Test pressure and temperature are maintained until specimen seal leaks or until the end of prescribed duration.

3.5 More than one specimen may be tested at one time in the fixture.

4. Significance and Use

4.1 Static seal failures are predominately due to incompatibility with media, degradation by temperature extremes, and extrusion stress. This test method may be used for relative performance evaluation screening, and is normally the second stage of the screening process after immersion testing in accordance with Test Method E1068.

4.2 This test method shows relative performance of materials under the combined effects of temperature, pressure, and extrusion stress. It does not necessarily correlate with actual service conditions. This test method is not intended to include the effect of test media.

4.3 A variety of test parameter combinations are provided so that evaluations can be made for a specific application.

4.4 This test method uses standard O-rings as test specimens.

5. Apparatus

5.1 *Test Fixture*, is shown in Fig. 1.

5.2 The apparatus shall include an oven for heating the test fixture to a controlled temperature as selected.

5.2.1 The oven should be protected from damage by test fluid leakage due to seal failure.

5.3 *Safety Controls*, shall be provided to protect the test fixture from overpressure and overheating.

5.4 *Fixture Rings*, should all provide the same clearance gap for any specific test.

5.5 Standard clearance gaps are given in Table 1.

6. Test Fluid

6.1 The test fluid is distilled water.

7. Test Temperature

7.1 The test temperature shall be one selected from Table 2.

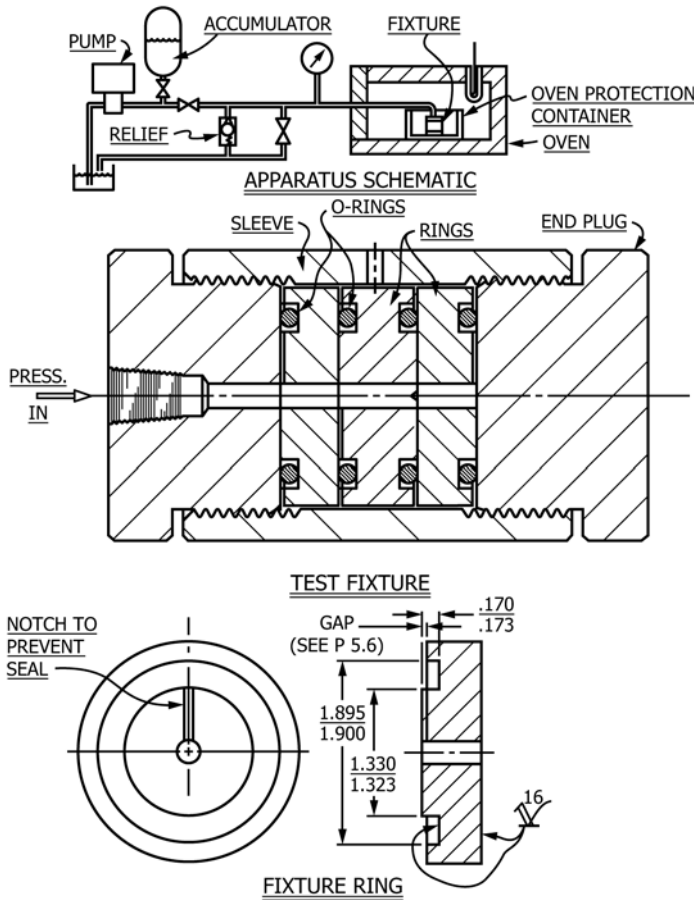

FIG. 1 Test Apparatus

TABLE 1 Standard Clearance Gaps

millimetres	inches
0.051 ± 0.0025	0.002 ± 0.0001
0.127 ± 0.0051	0.005 ± 0.0002
0.254 ± 0.0101	0.010 ± 0.0004
0.381 ± 0.0127	0.015 ± 0.0005
0.762 ± 0.0127	0.030 ± 0.0005

TABLE 2 Standard Test Temperature

°C	°F
85 ± 2	185 ± 4
100 ± 2	212 ± 4
150 ± 2	302 ± 4
200 ± 2	392 ± 4
250 ± 2	482 ± 4
300 ± 5	572 ± 9
350 ± 5	662 ± 9

8. Test Pressure

8.1 The test pressure, ±5 %, shall be one selected from Table 3.

9. Test Specimen

9.1 Standard specimens are o-rings with a 37.47 mm (1.475 in.) inside diameter and 5.33 mm (0.210 in.) diameter cross section, as specified in ANSI/SAE AS568A(size dash number – 325).

TABLE 3 Standard Test Pressure

MPa	psia
0.69	100
1.72	250
3.45	500
6.89	1000
13.79	2000
20.68	3000
34.47	5000
68.95	10000
103.42	15000

9.2 Elastomeric test specimens shall be made to dimensions and tolerances specified in ANSI/SAE AS568A.

9.3 Specimens of materials which have elastic properties that prevent proper sealing performance in the standard test fixture, may be modified in dimension or shape, or both.

9.4 O-Ring seal specimen shall be measured in accordance with Test Methods D1414 and ANSI/SAE AS568A.

10. Test Duration

10.1 Test duration shall be as specified in 11.2 or until failure, whichever occurs first.

10.2 Standard test durations are as follows (–0 %, + 2 %): 6, 70, and 120 h.

10.3 Test duration begins when both the selected temperature and pressure are reached.

11. Procedure

11.1 Assemble the test apparatus with test specimens.

11.2 Completely fill test fixture and apparatus piping with test fluid. This displaces air in the system.

11.3 Heat test fixture to the selected temperature. While heating, vent excessive pressure build up, but maintain a positive system pressure not to exceed test pressure.

11.4 Apply test pressure to the test fixture.

11.5 Test duration begins when both the selected temperature and pressure are reached.

11.6 At the end of the test, cool the test fixture to less than boiling temperature at atmospheric pressure and bleed pressure before opening the fixture.

12. Report

12.1 The report shall include specimen description including material type and actual dimensions and weight of specimens before and after test.

12.2 The report shall include the following:

12.2.1 Identification of specimen.

12.2.2 Test temperature.

12.2.3 Test pressure.

12.2.4 Test duration, and if failure occurred.

12.2.5 Gap dimension that seal bridged.

12.2.6 Dates test was run.

12.3 The report shall describe the condition of the specimen at the end of the test according to manual and visual inspection,

such features as deformation, weight percent of o-ring extruded into gap, discoloration, brittleness, hardness, etc.

12.4 The report shall identify the testing organization, and date of report.

13. Precision and Bias

13.1 This test method is intended for screening materials for adequacy of strength for an intended application. Pressure, temperature, and gap limits may be thus selected for the application.

13.2 Results are normally pass fail, so they are biased to failure times less than maximum test duration.

13.3 Specimen condition descriptions (see 13.3) are necessarily subjective. Precision and bias of the reported information should be judged as such.

14. Keywords

14.1 extrusion stress; geothermal fluids; geothermal liquids; polymeric seal; polymeric seal material; pressure stress; static sealing stress; temperature stress

ASTM International takes no position respecting the validity of any patent rights asserted in connection with any item mentioned in this standard. Users of this standard are expressly advised that determination of the validity of any such patent rights, and the risk of infringement of such rights, are entirely their own responsibility.

This standard is subject to revision at any time by the responsible technical committee and must be reviewed every five years and if not revised, either reapproved or withdrawn. Your comments are invited either for revision of this standard or for additional standards and should be addressed to ASTM International Headquarters. Your comments will receive careful consideration at a meeting of the responsible technical committee, which you may attend. If you feel that your comments have not received a fair hearing you should make your views known to the ASTM Committee on Standards, at the address shown below.

This standard is copyrighted by ASTM International, 100 Barr Harbor Drive, PO Box C700, West Conshohocken, PA 19428-2959, United States. Individual reprints (single or multiple copies) of this standard may be obtained by contacting ASTM at the above address or at 610-832-9585 (phone), 610-832-9555 (fax), or service@astm.org (e-mail); or through the ASTM website (www.astm.org). Permission rights to photocopy the standard may also be secured from the Copyright Clearance Center, 222 Rosewood Drive, Danvers, MA 01923, Tel: (978) 646-2600; <http://www.copyright.com/>