



Standard Test Method for Interfacial Tension of Oil Against Water by the Ring Method¹

This standard is issued under the fixed designation D971; the number immediately following the designation indicates the year of original adoption or, in the case of revision, the year of last revision. A number in parentheses indicates the year of last reapproval. A superscript epsilon (ϵ) indicates an editorial change since the last revision or reapproval.

This standard has been approved for use by agencies of the U.S. Department of Defense.

1. Scope

1.1 This test method covers the measurement of the interfacial tension between mineral oil and water, under non-equilibrium conditions.

1.2 *This standard does not purport to address all of the safety concerns, if any, associated with its use. It is the responsibility of the user of this standard to establish appropriate safety and health practices and determine the applicability of regulatory limitations prior to use.*

2. Referenced Documents

2.1 ASTM Standards:²

D117 [Guide for Sampling, Test Methods, and Specifications for Electrical Insulating Oils of Petroleum Origin](#)

D923 [Practices for Sampling Electrical Insulating Liquids](#)

D2285 [Test Method for Interfacial Tension of Electrical Insulating Oils of Petroleum Origin Against Water by the Drop-Weight Method](#) (Withdrawn 2008)³

3. Summary of Test Method

3.1 *Interfacial Tension* is determined by measuring the force necessary to detach a planar ring of platinum wire from the surface of the liquid of higher surface tension, that is, upward from the water-oil interface. To calculate the interfacial tension, the force so measured is corrected by an empirically determined factor which depends upon the force applied, the densities of both oil and water, and the dimensions of the ring. Measurements are made under rigidly standardized nonequilibrium conditions in which the measurement is completed within 60 s after formation of the interface.

¹ This test method is under the jurisdiction of ASTM Committee D27 on Electrical Insulating Liquids and Gases and is the direct responsibility of Subcommittee D27.07 on Physical Test.

Current edition approved May 1, 2012. Published May 2012. Originally approved in 1948 as D971 – 48 T. Last previous edition approved in 2004 as D971 – 99a(2004). DOI: 10.1520/D0971-12.

² For referenced ASTM standards, visit the ASTM website, www.astm.org, or contact ASTM Customer Service at service@astm.org. For *Annual Book of ASTM Standards* volume information, refer to the standard's Document Summary page on the ASTM website.

³ The last approved version of this historical standard is referenced on www.astm.org.

4. Significance and Use

4.1 Interfacial tension measurements on electrical insulating oils provide a sensitive means of detecting small amounts of soluble polar contaminants and products of oxidation. A high value for new mineral insulating oil indicates the absence of most undesirable polar contaminants. The test is frequently applied to service-aged oils as an indication of the degree of deterioration.

5. Apparatus (Figs. 1 and 2)

5.1 *Tensiometer*⁴—Force measurement on the tensiometer may be made using a torsion wire, load cell, or any other means of linearly determining tension in the range of 0 to 100 mN/m.

5.1.1 Horizontal platform to hold the sample container should be capable of movement upward or downward using a mechanical screw, lever mechanism, electronic drive, or any other means of precisely changing vertical position of the sample.

5.2 Rings made of platinum or platinum-iridium alloy may be used. The ring should be welded into a continuous circle and attached to at least two parallel stirrups. Circumference of the ring should be minimum 40 mm and diameter of the ring wire should be about 0.3 mm. Ratio of the ring major radius (R) and the wire radius (r) should be known (R/r) to at least three significant figures. Stirrups should be at least 25 mm long.

5.2.1 The ring may be suspended from or rigidly fixed into the tensiometer force measuring system.

5.3 *Sample Container*—Glass beaker or clear cylindrical container having a minimum diameter of 45 mm.

6. Reagents

6.1 *Purity of Reagents*—Reagent grade chemicals shall be used in the test.

6.2 *Purity of Water*—Unless otherwise indicated, references to water shall be understood to mean distilled water or water of equal purity.

⁴ Tensiometers that use the Du Nouy principle for measuring interfacial and surface tension should be used.

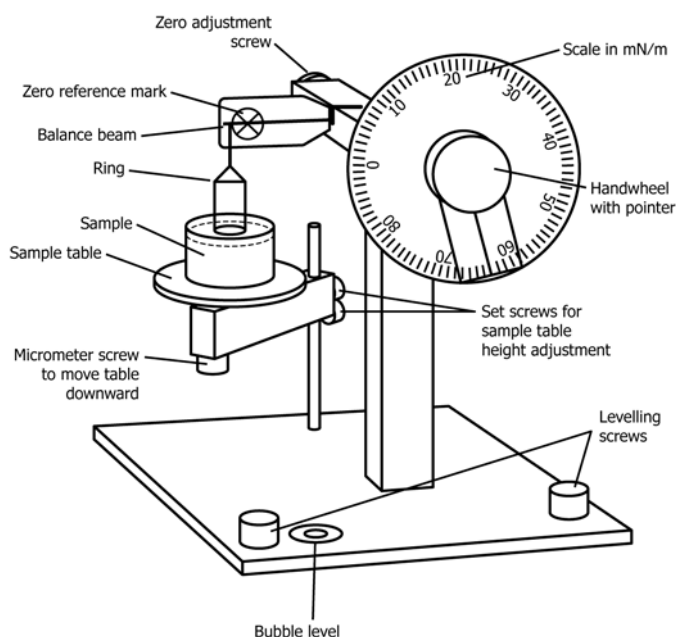

FIG. 1 Interfacial Tensiometer

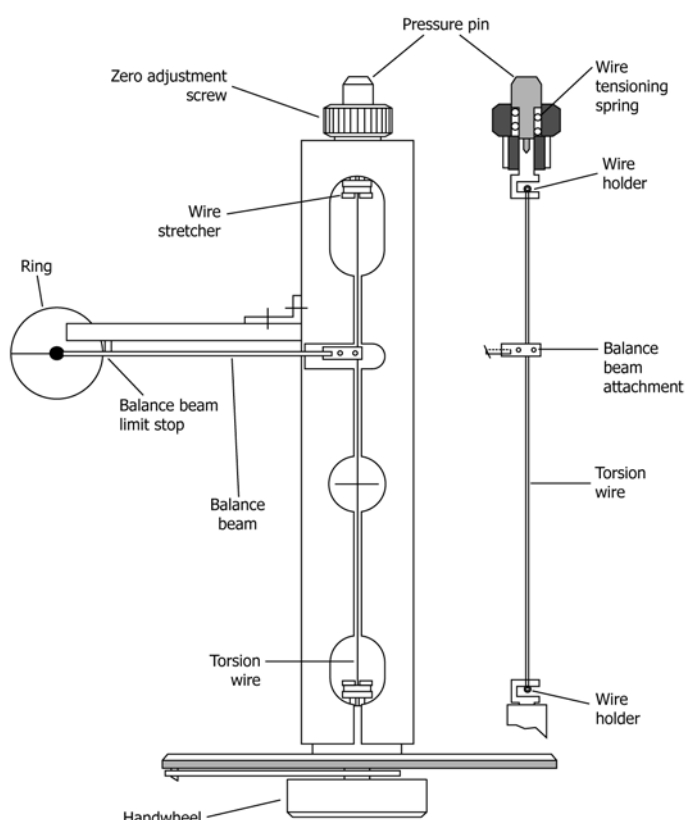

FIG. 2 Top View of Interfacial Tensiometer

7. Preparation of Apparatus

7.1 Glass containers can be cleaned by rinsing in xylene, hexane or another suitable hydrocarbon solvent, followed by a rinse in acetone or methyl ethyl ketone. Following these rinses they can be cleaned using detergent in hot water and rinsed

thoroughly with tap and then distilled water. Dry the glass vessel if not for immediate use.

7.2 The ring should be cleaned by immersing it in a small container of xylene, hexane or another suitable hydrocarbon solvent for at least 5 s while spinning the ring back and forth. Next, repeat this rinse using a container filled with acetone or methyl ethyl ketone. Flame the ring in a gas flame, again spinning it to obtain rapid, uniform heating. The ring should barely glow orange and should be heated for no more than 5 s. Clean the ring immediately before each measurement.

7.3 The tensiometer should be leveled by placing a bubble level device on the sample platform, if not equipped with one, and adjusting the tensiometer base until the platform is level.

8. Calibration of Apparatus

8.1 Calibrate the tensiometer against known weights and adjust its zero point according to the procedure of its manufacturer. Make certain that all portions of the ring are in the same horizontal plane.

9. Procedure

9.1 Preparation of Test Specimens:

9.1.1 Obtain a representative test specimen of liquid, at least 25 mL, to be studied in accordance with Test Method D923.

9.1.2 Obtain a fresh aliquot of distilled water (50 to 75 mL) at room temperature for interfacial tension measurements.

9.1.3 Test specimens should be covered, capped, or sealed immediately after they are obtained. Atmospheric dust and vapor can easily contaminate water, as can the growth of bacteria. Store test specimen in the dark at room temperature.

9.1.4 Temperature of test specimen and temperature of distilled water should agree within $\pm 1^\circ\text{C}$.

9.2 Determination of Test Specimen Density:

9.2.1 Determine test specimen density at room temperature using a liquid pycnometer or other density measuring device to $\pm 0.001 \text{ g/cm}^3$.

9.3 Interfacial Tension Measurement:

9.3.1 Introduce distilled water at room temperature into a clean sample container to a depth of 10 to 15 mm. Place it on the tensiometer platform so that the ring comes down in the center of the container and is not close to any wall. Make sure no foam is present at the water surface. If foam is visible, discard the water. Foam indicates that the water is contaminated or that the vessel is not clean.

9.3.2 Clean the ring and mount it in the tensiometer. Follow the manufacturer's instructions on zeroing the ring in air.

9.3.3 Raise the platform until the ring is immersed to a depth not to exceed 6 mm into the water.

9.3.4 Slowly lower the platform and follow the manufacturer's instructions on how to adjust the tensiometer reading. Increase torque on the reading dial while maintaining the torsion arm in the zero position. As the film of liquid adhering to the ring approaches the breaking point, proceed slowly with adjustments. This will ensure that the torsion beam will be in the zero position when rupture occurs. Rupture the surface by continuing to increase the force and lowering the vessel. Record the reading when rupture occurs.

9.3.5 Surface tension is calculated as described in 10.2, using the value 0.997 g/cm^3 for $(D-d)$, the difference in density between water and air. A value of 71–73 mN/m must be obtained. If low values are found, clean and rinse the sample container thoroughly and obtain a fresh sample of water from a different source of supply. If low surface tension values are still obtained, check calibration of the tensiometer and examine the ring to ensure the plane of the ring is parallel to the water surface.

9.3.6 Carefully layer the oil on the surface of the water (with the ring submerged) until a depth of at least 10 mm is reached. One such procedure is to pipette the oil onto the surface slowly so that minimum mixing occurs and so that oil does not touch the surface of the submerged ring. Make sure that the oil is not so deep as to cover the ring cross bar.

9.3.7 Allow the oil-water interface to age for $30 \pm 1 \text{ s}$ after the last of the oil has been layered onto the water.

9.3.8 Lower the platform as in 9.3.4 and record the value at rupture. Time this part of the measurement so that, as nearly as possible, 30 s are required to draw the ring through the interface. Proceed very slowly as the breaking point is approached, since the break is usually sluggish (due to viscosity of the oil). Complete the entire operation, from the time of pouring the oil onto the water until the interface ruptures, in about $60 \pm 10 \text{ s}$.

10. Calculation

10.1 Calculate the interfacial tension of the sample by means of the following equation;

$$\text{Interfacial tension, mN/m} = P \times F$$

where:

P = scale reading when film ruptures, mN/m (Note 1), and
 F = factor converting scale reading in mN/m to interfacial tension obtained as described in 10.2.

NOTE 1—If the scale is not graduated in millinewtons per metre, or if either the ring or the platinum wire are of different diameters than those for which the scale is graduated, correct the scale readings to millinewtons per metre for the particular ring used.

10.2 Using the value of diameter ratio, R/r , specified by the manufacturer for the rings used, determine the correction factor F to three digits by means of the following equation. Alternatively, prepare a graph⁵ of correction factors, F . The

⁵ For a description of procedure, see Zuidema and Waters, *Industrial and Engineering Chemistry*, Analytical Edition, IENAA, Vol 13, 1941, p. 312.

ASTM International takes no position respecting the validity of any patent rights asserted in connection with any item mentioned in this standard. Users of this standard are expressly advised that determination of the validity of any such patent rights, and the risk of infringement of such rights, are entirely their own responsibility.

This standard is subject to revision at any time by the responsible technical committee and must be reviewed every five years and if not revised, either reapproved or withdrawn. Your comments are invited either for revision of this standard or for additional standards and should be addressed to ASTM International Headquarters. Your comments will receive careful consideration at a meeting of the responsible technical committee, which you may attend. If you feel that your comments have not received a fair hearing you should make your views known to the ASTM Committee on Standards, at the address shown below.

This standard is copyrighted by ASTM International, 100 Barr Harbor Drive, PO Box C700, West Conshohocken, PA 19428-2959, United States. Individual reprints (single or multiple copies) of this standard may be obtained by contacting ASTM at the above address or at 610-832-9585 (phone), 610-832-9555 (fax), or service@astm.org (e-mail); or through the ASTM website (www.astm.org). Permission rights to photocopy the standard may also be secured from the Copyright Clearance Center, 222 Rosewood Drive, Danvers, MA 01923, Tel: (978) 646-2600; http://www.copyright.com/

graph should cover even increments of $P/(D-d)$ from 0 to 800 and should give correction factors to three digits:

$$F = 0.7250 + \sqrt{\frac{1.452P}{C^2(D-d)} + 0.04534} - \frac{1.679}{R/r}$$

where:

P = scale reading, mN/m,
 C = circumference of ring, mm,
 D = density of water at test temperature, g/mL,
 d = density of test specimen at test temperature, g/mL,
 R = radius of ring, mm, and
 r = radius of wire of ring, mm.

11. Report

11.1 Report the following information:

11.1.1 Identification of test specimen,

11.1.2 Density used for calculations (water and test specimen), and

11.1.3 Test method used and interfacial tension in mN/m.

12. Precision and Bias

12.1 The following criteria should be used for judging the acceptability of results (95 % confidence).

12.2 *Repeatability*—The difference between successive test results obtained by the same operator with the same apparatus under constant operating conditions on identical test material would, in the long run, in the normal and correct operation of the test method, exceed the following values only in one case in twenty: $0.04 \bar{X}$, where \bar{X} denotes mean value.

12.2.1 *Reproducibility*—The difference between two single and independent results, obtained by different operators working identical test material would, in the long run, in the normal and correct operation of the test method, exceed the following values only in one case in twenty: $0.10 \bar{X}$, where \bar{X} denotes mean value.

12.3 *Bias*—There being no criteria for measuring bias in these test-product combinations, no statement of bias can be made.

13. Keywords

13.1 interfacial tension; surface tension; tensiometer; transformer oil