



Designation: D968 – 17

Standard Test Methods for Abrasion Resistance of Organic Coatings by Falling Abrasive¹

This standard is issued under the fixed designation D968; the number immediately following the designation indicates the year of original adoption or, in the case of revision, the year of last revision. A number in parentheses indicates the year of last reapproval. A superscript epsilon (ϵ) indicates an editorial change since the last revision or reapproval.

This standard has been approved for use by agencies of the U.S. Department of Defense.

1. Scope*

1.1 These test methods cover the determination of the resistance of organic coatings to abrasion produced by abrasive falling onto coatings applied to a plane rigid surface, such as a metal or glass panel.

1.2 Two test methods based on different abrasives are covered as follows:

	Sections
Method A—Falling Sand Abrasion Test	6 – 13
Method B—Falling Silicon Carbide Abrasion Test	14 – 21

1.3 These methods should be restricted to testing in only one laboratory when numerical values are used because of the poor reproducibility of the methods (see 13.1.2 and 21.1.2). Interlaboratory agreement is improved significantly when ranking is used in place of numerical values.

1.4 The values stated in SI units are to be regarded as the standard with the exception of mils when determining coating thickness. The values given in parentheses are for information only.

1.5 *This standard does not purport to address the safety concerns, if any, associated with its use. It is the responsibility of the user of this standard to establish appropriate safety and health practices and determine the applicability of regulatory limitations prior to use.*

1.6 *This international standard was developed in accordance with internationally recognized principles on standardization established in the Decision on Principles for the Development of International Standards, Guides and Recommendations issued by the World Trade Organization Technical Barriers to Trade (TBT) Committee.*

¹ These test methods are under the jurisdiction of ASTM Committee D01 on Paint and Related Coatings, Materials, and Applications and are the direct responsibility of Subcommittee D01.23 on Physical Properties of Applied Paint Films.

Current edition approved June 1, 2017. Published June 2017. Originally approved in 1948. Last previous edition approved in 2015 as D968 – 15. DOI: 10.1520/D0968-17.

2. Referenced Documents

2.1 ASTM Standards:²

D823 Practices for Producing Films of Uniform Thickness of Paint, Varnish, and Related Products on Test Panels

D1005 Test Method for Measurement of Dry-Film Thickness of Organic Coatings Using Micrometers

D7091 Practice for Nondestructive Measurement of Dry Film Thickness of Nonmagnetic Coatings Applied to Ferrous Metals and Nonmagnetic, Nonconductive Coatings Applied to Non-Ferrous Metals

E11 Specification for Woven Wire Test Sieve Cloth and Test Sieves

2.2 Other Standards:

ANSI B74.12 Specifications for the Size of Abrasive Grain — Grinding Wheels, Polishing and General Industrial Uses³

FEPA Standard 42-2:2006 Grains of Fused Aluminum Oxide, Silicon Carbide and other Abrasive Materials for Bonded Abrasives and for General Applications — Micrometers F230 to F2000⁴

3. Terminology

3.1 Definitions of Terms Specific to This Standard:

3.1.1 *abrasion resistance, n*—the amount of abrasive required to wear through a unit film thickness of the coating.

4. Summary of Test Method

4.1 Abrasive is allowed to fall from a specified height through a guide tube onto a coated panel until the substrate becomes visible. The amount of abrasive per unit film thickness is reported as the abrasion resistance of the coating on the panel. Silica sand or silicon carbide may be used, as specified.

² For referenced ASTM standards, visit the ASTM website, www.astm.org, or contact ASTM Customer Service at service@astm.org. For *Annual Book of ASTM Standards* volume information, refer to the standard's Document Summary page on the ASTM website.

³ Available from American National Standards Institute (ANSI), 25 W. 43rd St., 4th Floor, New York, NY 10036, http://www.ansi.org.

⁴ Available from Federation of European Producers of Abrasives (FEPA), 20 av., Reille, Paris, F-75014, www.fepa-abrasives.com.

*A Summary of Changes section appears at the end of this standard



FIG. 1 Apparatus for Falling Sand Abrasion Test

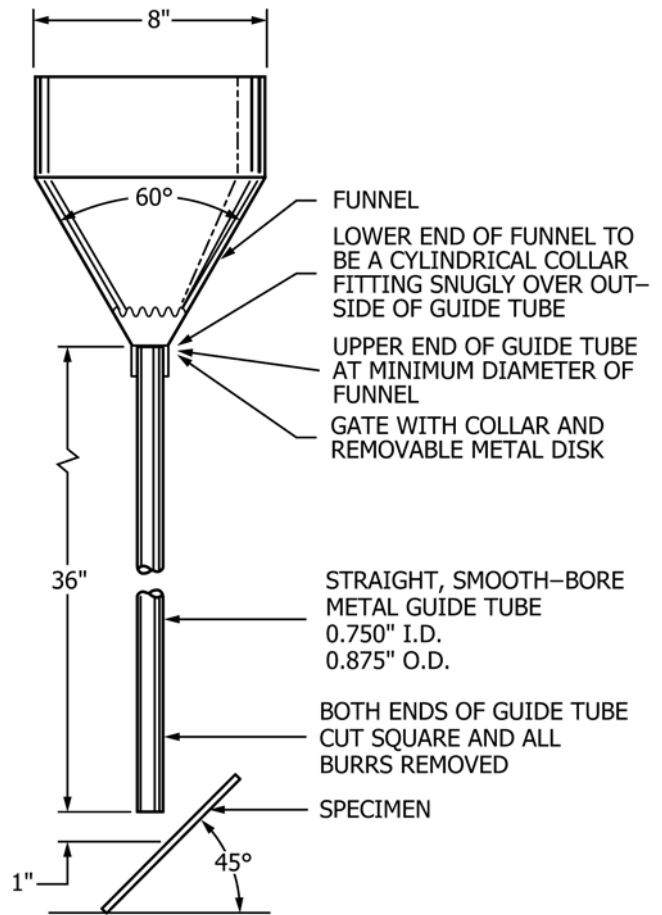

NOTE 1—All dimensions are given in inches. 1 in. = 25.4 mm.

FIG. 2 Design Details of Abrasion Test Apparatus

5. Significance and Use

5.1 Silica sand produces a slower rate of abrasion for organic coatings than that provided by silicon carbide. For some types of coatings, it may also provide greater differentiation.

5.2 The abrasion resistance scales produced by the two methods differ, but the methods provide approximately the same rankings of coatings for abrasion resistance.

5.3 Each of the methods has been found useful for rating the abrasion resistance of specific types of coatings. For example Method A (falling sand) has been used for rating floor coatings while Method B (falling silicon carbide) has been used for rating coatings for ship decks.

METHOD A—FALLING SAND ABRASION TEST⁵

6. Apparatus and Materials

6.1 *Abrasion Tester*, as illustrated in Fig. 1 and Fig. 2. A gate for starting the flow of abrasive is located near the top of the guide tube. It consists of a metal disk inserted into a slit in the side of the guide tube with a collar covering the slit. The guide tube shall be firmly supported in a vertical position over a suitable receptacle, which shall contain a support for holding the coated panel at an angle of 45° to the vertical. The opening of the tube is directly above the area to be abraded and the

distance from the tube to the coated surface face at the nearest point is 25 mm (1 in.) when measured in the vertical direction. The base of the apparatus shall be fitted with adjusting screws for properly aligning the equipment.

6.2 *Standard Abrasive*—Natural silica sand from the St. Peters or Jordan sandstone deposits (located in the central United States) shall be considered standard when graded as follows after 5 min of continuous sieving. Use the sieves described in Specification E11.

- 0 % retained on a No. 16 (1.18 mm) sieve
- Maximum 15 % retained on a No. 20 (850 μm) sieve
- Minimum 80 % retained on a No. 30 (600 μm) sieve
- Maximum 5 % passing a No. 30 (600 μm) sieve

The sand is characterized by its grain shape and has a silicon dioxide content greater than 99 %.

NOTE 1—The abrading qualities of sand obtained from different sources may differ slightly even though the sand meets the sieve requirements. Therefore, for maximum precision of test results, purchaser and seller should use sand from the same source.

7. Test Specimens

7.1 Apply uniform coatings of the material to be tested to a plane, rigid surface such as a metal or glass panel. Prepare a minimum of two coated panels for the material.

⁵ Hipkins, C. C., and Phain, R. J., "The Falling Sand Abrasion Tester," *ASTM Bulletin*, No. 143, December 1946, pp. 18–22.

7.2 Cure the coated panels under the conditions of humidity and temperature agreed upon between the purchaser and seller.

NOTE 2—The coatings should be applied in accordance with Practices D823, or as agreed upon between the purchaser and the seller.

NOTE 3—The thickness of the dry coatings should be measured in accordance with Test Methods D1005 or D7091.

NOTE 4—While the minimum of two coated panels is acceptable, evaluating three or more panels per material will provide greater confidence in your test results.

8. Standardization

8.1 Pour a quantity of standard sand into the funnel and examine the sand stream falling from the lower end of the guide tube. Align the apparatus by means of the adjusting screws in the base until the inner concentrated core of the sand stream falls in the center of the flow when viewed at two positions at 90° to each other. Introduce a measured volume of sand (2000 ± 10 mL is a convenient amount) and determine the time of efflux. The rate of flow shall be 2 L of sand in 21 to 23.5 s.

8.2 Secure a trial panel in the testing position, as described in 6.1, and introduce the sand in increments until a spot 4 mm ($\frac{5}{32}$ in.) in diameter is worn through to the base material. The overall abraded area shall be elliptical in shape, about 25 mm (1 in.) in width and 30 mm ($1\frac{1}{4}$ in.) in length. The center of the area of maximum abrasion shall be on the centerline through the longer axis of the abraded pattern and within 14 to 17 mm ($\frac{9}{16}$ to $1\frac{1}{16}$ in.) of the top edge. Slight final adjustment of the instrument may be required to center the abrasion spot in the pattern.

8.3 A final check on alignment is made by determining the amount of sand that passes through a 4-mm ($\frac{5}{32}$ -in.) hole in a metal panel placed directly under the tube. Place a container under the hole in the panel and allow a weighed amount of sand to pass through the tube onto the panel. Weigh the amount of sand that passed through the hole into the container. The apparatus can be considered to be in calibration if the amount of sand that passed through the hole is 90 to 93 % of the amount of sand that impinged on the panel.

9. Conditioning

9.1 Unless otherwise agreed upon between purchaser and seller, condition the coated test panels for at least 24 h at 23 ± 2°C and 50 ± 5 % relative humidity. Conduct the test in the same environment or immediately on removal therefrom.

10. Procedure

10.1 On each coated panel mark three circular areas, each approximately 25 mm (1 in.) in diameter, and so arranged that each can be properly positioned in the panel support of the abrasion tester. Measure the thickness of the coating by Test Methods D1005 or D7091 in at least three locations in each area. Record the mean of each set of measurements as the thickness of the coating over the respective area.

10.2 After conditioning, secure the coated panel in the tester as described in 6.1. Adjust the panel so that one of the marked areas will be centered under the guide tube.

10.3 Pour standard sand, measured volumetrically, into the funnel. Withdraw the gate and allow the sand to flow through the guide tube and impinge on the coated panel. Collect the sand in a container located at the bottom of the tester. Repeat this operation until a 4-mm ($\frac{5}{32}$ -in.) diameter area of the coating has worn through to the substrate. A convenient increment of sand to employ during the test is 2000 ± 10 mL. As the end-point is approached, increments of 200 ± 2 mL may be introduced into the funnel.

NOTE 5—When the gate is withdrawn from the guide tube, make certain that a collar covers the slit opening in the tube.

10.4 Abrade each of the remaining marked-off areas of the coated panel as outlined in 10.2.

NOTE 6—Check the alignment of the guide tube at frequent intervals to ensure that the concentrated inner core of the sand stream is falling in the center of the flow.

NOTE 7—After 25 passes through the apparatus, resieve the sand with a No. 30 sieve to remove fines. Replace the sand after 50 passes.

NOTE 8—Sand should be stored in a humidity controlled environment. Excessive moisture level of the sand may influence the results and can be corrected by drying the sand for 1 h in an oven at approximately 82°C (180°F).

10.5 Repeat 10.1 – 10.4 on at least one additional panel coated with the material under test.

11. Calculation

11.1 For each area of the coated panel tested, calculate the abrasion resistance, A , in litres per mil from the following equation:

$$A_{\text{volume}} = V/T \quad (1)$$

where:

V = volume of abrasive used, L (to one decimal place) and
 T = thickness of coating, mils (to one decimal place).

11.2 Calculate the mean of the abrasion resistance values obtained for different areas of the coated panel and the mean value of the replicate panels.

12. Report

12.1 Report the following information for each coated panel tested:

12.1.1 Temperature and humidity during curing and at the time of testing,

12.1.2 Type and source of abrasive,

12.1.3 Litres of abrasive used for each area tested,

12.1.4 Wear pattern measurements, if different than 8.2,

12.1.5 Coating thickness in mils for each area tested,

12.1.6 Abrasion resistance values for each area tested,

12.1.7 Mean abrasion resistance for each coated panel tested, and

12.1.8 Mean abrasion resistance and range of the replicate coated panels.

13. Precision ⁶

13.1 On the basis of an interlaboratory test of this test method in which three laboratories tested four types of coatings

⁶ Supporting data have been filed at ASTM International Headquarters and may be obtained by requesting Research Report RR:D01-1037. Contact ASTM Customer Service at service@astm.org.

differing in their abrasion resistance, the within-laboratory coefficient of variation was found to be 9 % with 22 df and the between-laboratories coefficient of variation 35 % with 7 df. Based on these coefficients, the following criteria should be used for judging the acceptability of results at the 95 % confidence level.

13.1.1 *Repeatability*—Two results, each the mean of three runs, obtained by the same operator should be considered suspect if they differ by more than 25 % of their mean value.

13.1.2 *Reproducibility*—Two results, each the mean of three runs, obtained by operators in different laboratories should be considered suspect if they differ by more than 118 % of their mean value.

NOTE 9—The reproducibility of this test is improved substantially when rankings of the coatings by magnitude of abrasion resistance are used. In the interlaboratory test for evaluating precision, all laboratories ranked the coatings in the same order.

13.2 *Bias*—At the time of the study, there was no accepted reference material suitable for determining bias for this test method, therefore no statement on bias is being made.

METHOD B—FALLING SILICON CARBIDE TEST

14. Apparatus and Materials

14.1 *Abrasion Tester*, as described in 6.1, with two exceptions:

14.1.1 A metal washer with an opening of 8.5 ± 0.1 mm is centered in the bottom opening of the funnel to restrict the flow of the abrasive.

14.1.2 The disk gate installed in a slit at the top of the guide tube may be replaced by a gate in the bottom of the funnel. This gate consists of a solid metal disk attached to a long vertical screw and mounted above the washer.

14.2 *Standard Abrasive*—Silicon carbide grain shall be considered standard when graded as follows after 5 min of continuous sieving:

- 0 % retained on a No. 10 (2.00 mm) sieve
- Maximum of 20 % retained on a No. 14 (1.40 mm) sieve
- Minimum of 45 % retained on a No. 16 (1.18 mm) sieve
- Minimum of 70 % retained on a No. 16 (1.18 mm) and No. 18 (1.00 mm) sieve
- 3 % Maximum passes a No. 20 (850 μ m) sieve

These grading requirements correspond to No. 16 grit in accordance with ANSI B74.12. These grading requirements also correspond to F16 grit in accordance with FEPA Standard 42-2:2006.

14.2.1 Use the sieves described in Specification E11.

15. Test Specimens

15.1 Prepare the coated panels as outlined in 7.1 and 7.2.

16. Standardization

16.1 Standardize the abrasion tester by the procedures given in 8.1 – 8.3, with the following exceptions:

16.1.1 Use silicon carbide grain where sand is specified.

16.1.2 Weigh the volume of silicon carbide grain to be introduced into the tester. Determine the efflux time for this volume. The rate of flow shall be 10 ± 1 g/s.

17. Conditioning

17.1 Unless otherwise agreed upon between purchaser and seller, condition the coated panels for at least 24 h at $23 \pm 2^\circ\text{C}$ and 50 ± 5 % relative humidity. Conduct the test in the same environment or immediately on removal therefrom.

18. Procedure

18.1 Measure the thickness of the coating by the procedures given in 10.1.

18.2 Abrade the coated panel by the procedures given in 10.1 – 10.4 using silicon carbide as the abrasive. Determine the volume or weight, or both, of abrasive used to reach the end point.

18.3 Repeat 18.1 and 18.2 on at least one additional coated panel of the material under test.

19. Calculation

19.1 For each area of the coated panel tested, calculate the abrasion resistance in litres per mil from the equation given in 11.1 or, calculate the abrasion resistance, A , in kilograms per mil from the equation:

$$A_{weight} = W/T \quad (2)$$

where:

W = weight of abrasive used, kg (to one decimal place) and
 T = thickness of coating, mils (to one decimal place).

19.2 Calculate the mean of the abrasion resistance values obtained at different areas of the coated panel and the mean values of the replicate panels.

20. Report

20.1 Report the information specified in Section 12 for each coated panel tested. Abrasion resistance may be reported as litres per mil or as kilograms per mil.

21. Precision⁶

21.1 An interlaboratory test was conducted in which operators in three laboratories tested four coatings having a broad range of abrasion resistance. The within-laboratory coefficient of variation was 19 % with 16 df. The between-laboratories coefficient of variation was 45 % with 8 df. Based upon these coefficients, the following criteria should be used for judging the acceptability of results at the 95 % confidence level:

21.1.1 *Repeatability*—Two results, each the mean of three runs, obtained by the same operator should be considered suspect if they differ by more than 56 % of their mean value.

21.1.2 *Reproducibility*—Two results, each the mean of three runs, obtained by operators in different laboratories should be considered suspect if they differ by more than 147 % of their mean value. See Note 7.

21.2 *Bias*—At the time of the study, there was no accepted reference material suitable for determining bias for this test method, therefore no statement on bias is being made.

22. Keywords

22.1 abrasion; abrasion (of paints/related coatings); falling abrasive tester; falling sand abrasion test; falling silicon carbide abrasion test; resistance

SUMMARY OF CHANGES

Committee D01 has identified the location of selected changes to this standard since the last issue (D968–16) that may impact the use of this standard. (Approved June 1, 2017.)

(1) Added Note 8, suggesting sand be stored in a humidity controlled environment.

Committee D01 has identified the location of selected changes to this standard since the last issue (D968-15) that may impact the use of this standard. (Approved December 1, 2016.)

(1) Replaced image in Fig. 2.

(2) Added requirement to report wear pattern measurement in section 12.1.4.

ASTM International takes no position respecting the validity of any patent rights asserted in connection with any item mentioned in this standard. Users of this standard are expressly advised that determination of the validity of any such patent rights, and the risk of infringement of such rights, are entirely their own responsibility.

This standard is subject to revision at any time by the responsible technical committee and must be reviewed every five years and if not revised, either reapproved or withdrawn. Your comments are invited either for revision of this standard or for additional standards and should be addressed to ASTM International Headquarters. Your comments will receive careful consideration at a meeting of the responsible technical committee, which you may attend. If you feel that your comments have not received a fair hearing you should make your views known to the ASTM Committee on Standards, at the address shown below.

This standard is copyrighted by ASTM International, 100 Barr Harbor Drive, PO Box C700, West Conshohocken, PA 19428-2959, United States. Individual reprints (single or multiple copies) of this standard may be obtained by contacting ASTM at the above address or at 610-832-9585 (phone), 610-832-9555 (fax), or service@astm.org (e-mail); or through the ASTM website (www.astm.org). Permission rights to photocopy the standard may also be secured from the Copyright Clearance Center, 222 Rosewood Drive, Danvers, MA 01923, Tel: (978) 646-2600; <http://www.copyright.com/>