



# Standard Test Method for Impact Strength of Adhesive Bonds<sup>1</sup>

This standard is issued under the fixed designation D950; the number immediately following the designation indicates the year of original adoption or, in the case of revision, the year of last revision. A number in parentheses indicates the year of last reapproval. A superscript epsilon ( $\epsilon$ ) indicates an editorial change since the last revision or reapproval.

*This standard has been approved for use by agencies of the U.S. Department of Defense.*

## INTRODUCTION

The accuracy of the results of strength tests of adhesive bonds will depend on the conditions under which the bonding process is carried out. Unless otherwise agreed upon between the manufacturer and the purchaser, the bonding conditions shall be prescribed by the manufacturer of the adhesive. In order to ensure that complete information is available to the individual conducting the tests, the manufacturer of the adhesive shall furnish numerical values and other specific information for each of the following variables:

(1) Procedure for preparation of surfaces prior to application of the adhesive the cleaning and drying of metal surfaces, and special surface treatments such as sanding which are not specifically limited by the pertinent test method.

(2) Complete mixing directions for the adhesive.

(3) Conditions for application of the adhesive including the rate of spread or thickness of film, number of coats to be applied, whether to be applied to one or both surfaces, and the conditions of drying where more than one coat is required.

(4) Assembly conditions before application of pressure, including the room temperature, length of time, and whether open or closed assembly is to be used.

(5) Curing conditions, including the amount of pressure to be applied, the length of time under pressure and the temperature of the assembly when under pressure. It should be stated whether this temperature is that of the bond line, or of the atmosphere at which the assembly is to be maintained.

(6) Conditioning procedure before testing, unless a standard procedure is specified, including the length of time, temperature, and relative humidity.

A range may be prescribed for any variable by the manufacturer of the adhesive if it can be assumed by the test operator that any arbitrarily chosen value within such a range or any combination of such values for several variables will be acceptable to both the manufacturer and the purchaser of the adhesive.

## 1. Scope

1.1 This test method covers the determination of the comparative impact strength of adhesive bonds in shear, when tested on standard specimens under specified conditions of preparation, conditioning, and testing.

1.2 The values stated in SI units are to be regarded as the standard. The values in parentheses are for information only.

1.3 *This standard does not purport to address all of the safety concerns, if any, associated with its use. It is the*

*responsibility of the user of this standard to establish appropriate safety and health practices and determine the applicability of regulatory limitations prior to use.*

## 2. Referenced Documents

2.1 *ASTM Standards:*<sup>2</sup>

A108 [Specification for Steel Bar, Carbon and Alloy, Cold-Finished](#)

B16/B16M [Specification for Free-Cutting Brass Rod, Bar and Shapes for Use in Screw Machines](#)

<sup>1</sup> This test method is under the jurisdiction of ASTM Committee D14 on Adhesives and is the direct responsibility of Subcommittee D14.80 on Metal Bonding Adhesives.

Current edition approved April 1, 2011. Published April 2011. Originally approved in 1952. Last previous edition approved in 2003 as D950–03. DOI: 10.1520/D0950-03R11.

<sup>2</sup> For referenced ASTM standards, visit the ASTM website, [www.astm.org](http://www.astm.org), or contact ASTM Customer Service at [service@astm.org](mailto:service@astm.org). For *Annual Book of ASTM Standards* volume information, refer to the standard's Document Summary page on the ASTM website.

- [B107/B107M](#) Specification for Magnesium-Alloy Extruded Bars, Rods, Profiles, Tubes, and Wire
- [B133](#) Specification for Copper Rod, Bar, And Shapes (Withdrawn 1994)<sup>3</sup>
- [B139/B139M](#) Specification for Phosphor Bronze Rod, Bar, and Shapes
- [B151/B151M](#) Specification for Copper-Nickel-Zinc Alloy (Nickel Silver) and Copper-Nickel Rod and Bar
- [B211](#) Specification for Aluminum and Aluminum-Alloy Rolled or Cold Finished Bar, Rod, and Wire
- [D905](#) Test Method for Strength Properties of Adhesive Bonds in Shear by Compression Loading
- [D907](#) Terminology of Adhesives
- [E23](#) Test Methods for Notched Bar Impact Testing of Metallic Materials

### 3. Terminology

3.1 *Definitions*—Many terms in this test method are defined in Terminology [D907](#).

3.2 *Definitions of Terms Specific to This Standard:*

3.2.1 *impact strength, n*—the energy absorbed expressed in joules per square metre or foot-pounds-force (ft-lbf) per square inch, by a specimen of standard design when impacted to failure by a single blow of a testing-machine hammer. (Synonym *impact value*.)

3.2.2 *impact value, n*—synonym for *impact strength*.

### 4. Significance and Use

4.1 Adhesives can fail under a sudden impact load and not under a slowly applied load of the same or greater force.

4.2 This test method can be used to compare the sensitivity of various adhesives to suddenly applied loads.

### 5. Apparatus

5.1 *Testing Machine:*

5.1.1 A pendulum-type impact machine with a hand velocity of 3.4 m/s (11 ft/s), comprising essentially the following:

5.1.1.1 *Impact Head* equipped with a flat striking face slightly wider than the test specimen, aligned to strike the specimen full-face.

5.1.1.2 *Jig* to hold the test specimen, as shown in [Fig. 1](#). The jig illustrated is not suitable for use with all impact machines and vises. Vary the dimensions and design of the jig as required for adaptation to machines and vises available, provided the following general requirements are met: Machine the jig from a solid piece of steel and bolt it solidly to the base of the testing machine. Drill the corners to ensure that the test specimen sets flush against the retaining end of the jig. Minimize the dirt collection at the drilled corners which could hold the end of the specimen away from the face of the jig. Provide the jig with a screw to tighten the specimen in the jig, in order to minimize the tendency of the specimen to overturn when struck. Locate the jig so that the specimen will be struck at the point of maximum head velocity.

<sup>3</sup> The last approved version of this historical standard is referenced on [www.astm.org](http://www.astm.org).

5.1.1.3 *Vise or Bolts* to hold the jig rigid and immobile under the stress of the testing machine hammer with the total height of the vise, jig, and test specimen such that the lower edge of the striking face of the impact head strikes the specimen as near the adhesive line as possible, preferably within 0.79 mm ( $1/32$  in.). Ordinarily the distance between the top of the jaws of the vise of the machine and the bottom of the striking face of the head is 22 mm (0.866 in.), and proper height of the specimen may be obtained by adjusting its height in the jig.

5.1.2 See Test Methods [E23](#) for additional information on impact testing machines and their calibration.

5.2 *Conditioning Room or Desiccators*—A conditioning room capable of maintaining a relative humidity of  $50 \pm 2\%$  at  $23 \pm 1.1^\circ\text{C}$  ( $73.4 \pm 2^\circ\text{F}$ ), or desiccators filled with a saturated salt solution ([Note 1](#)) to give a relative humidity of  $50 \pm 2\%$  at  $23 \pm 1.1^\circ\text{C}$ .

**NOTE 1**—A saturated salt solution of calcium nitrate will give approximately 51 % relative humidity at the test temperature.

### 6. Test Specimens

6.1 *Metal-to-Metal Specimens:*

6.1.1 *Material*—Metals conforming to the following specifications are recommended:

Metal	Designation
Brass	ASTM <a href="#">B16/B16M</a> , C36000; half-hard temper
Copper	ASTM <a href="#">B133</a> , C11000; hard temper
Aluminum	ASTM <a href="#">B211</a> , A92024; G-3
Steel	AISI 1020, G10200; cold-finished bar
Phosphor bronze	ASTM <a href="#">B139/B139M</a> , C54400
Magnesium	ASTM <a href="#">B107/B107M</a> , AZ61A or M1A-F
Nickel silver	ASTM <a href="#">B151/B151M</a> , C77000; quarter-hard

6.1.1.1 Run tests on adhesives with high-impact strength preferably on steel to minimize deformation. The reuse of specimens is allowed, provided that the face receiving the impact is not deformed.

6.1.2 *Specimen Size, Shape, and Assembly*—Use the test specimen dimensions for metal-to-metal adhesives given in [Fig. 2\(a\)](#), whenever possible. In cases where this specimen cannot be fractured in the testing machine available, the square dimensions of the 25.4 by 25.4-mm (1 by 1-in.) block may be reduced to a smaller square, keeping the dimensions of the 25.4 by 44.5-mm (1 by  $1\frac{3}{4}$ -in.) block constant. Clearly state the dimensions of the specimen and bonded area in the report (Section 9). In any case, it is desirable that the specimen size be such as to give impact strengths that fall somewhere near the middle range of the testing machine, since readings in the highest and lowest ranges are often unreliable. Assemble the specimen so the face receiving the impact load is at the point of maximum velocity of the impact head. The impact face of the specimen is to be square and flat, perpendicular to the plane of the bond line, and parallel to the striking face of the pendulum.

6.1.3 *Bonding*—Apply adhesive and pressure in accordance with the procedure outlined by the manufacturer of the adhesive.

6.1.3.1 Prepare areas that are to be bonded in accordance with the recommendations of the manufacturer of the adhesive.

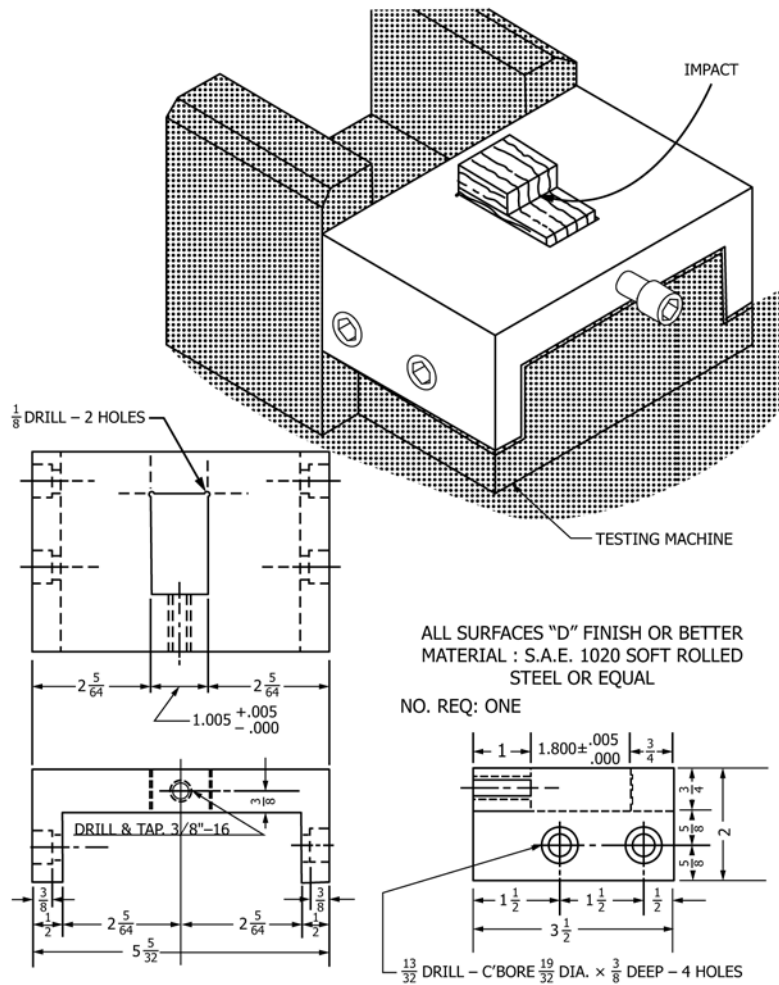

Inch-Pound Equivalents

mm	(in.)	mm	(in.)
3.2	( $\frac{1}{8}$ )	25.527 + 0.127	(1.005 + 0.005)
9.5	( $\frac{3}{8}$ )	-0.000	(-0.000)
12.7	( $\frac{1}{2}$ )	38.1	( $1\frac{1}{2}$ )
14.9	( $\frac{19}{32}$ )	45.720 + 0.127	(1.800 + 0.005)
16	( $\frac{5}{8}$ )	-0.000	(-0.000)
19	( $\frac{3}{4}$ )	50.8	(2)
25.4	(1)	52.8	( $2\frac{1}{4}$ )
		88.9	( $3\frac{1}{2}$ )
		131	( $5\frac{1}{2}$ )

FIG. 1 Adapter Jig for Impact Machines

6.1.4 *Conditioning*—Preconditioning is not required for metal-to-metal bonds. The adhesive is ready for test purposes when it has been applied in accordance with 6.1.3 unless otherwise specified by the manufacturer or the purchaser.

6.1.5 *Number of Test Specimens, Metal-to-Metal:*

6.1.5.1 Test ten test specimens for each adhesive in the case of metal-to-metal specimens.

6.1.5.2 Discard specimens that break at a flaw remote from the bond line. Retest unless such flaws constitute a variable the effect of which it is desired to study.

7. Testing Procedure

7.1 Place the specimen in the jig in the vise of the impact machine so that the specimen butts squarely against the

retaining end of the jig. Rest the impact head of the machine gently against the specimen and adjust the jig so that the head fits squarely against the impact face of the specimen.

7.2 Raise the impact head to a predetermined height and release the safety catch. The impact energy absorbed by the specimen may then be read directly.

7.3 Record the following information:

7.3.1 Record joules or foot pound-force of energy absorbed in producing failure of the specimen.

7.3.2 Record bonded area of specimen.

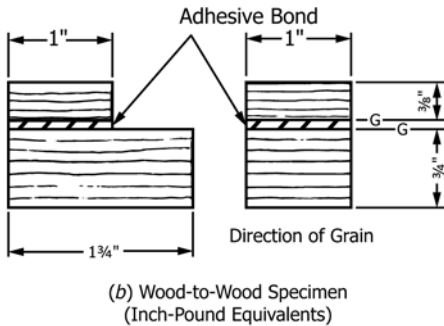
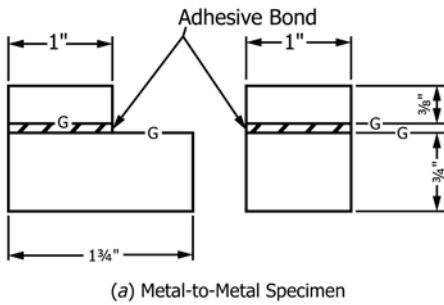

	9.5	19	25.4	44.4
mm	9.5	19	25.4	44.4
(in.)	(3/8)	(3/4)	(1)	(1 3/4)

FIG. 2 Block Shear Impact Test Specimens

## 8. Calculation

8.1 Calculate the impact strength of the specimen as the energy absorbed in producing failure of the specimen divided by the bonded area of the specimen, and express in joules per square metre or foot pound-force per square inch. Report the values to the nearest 100 J/m<sup>2</sup> (0.1 ft-lbf/in.<sup>2</sup>). Unit results cannot be extended to different areas than those tested.

## 9. Report

9.1 Report the following information:

9.1.1 Complete identification of the adhesive tested, including type, source, manufacturer's code numbers, form, etc.,

9.1.2 Method of preparing test specimens, dimensions of specimens, and materials bonded,

9.1.3 Average thickness of adhesive layer after formation of the joint, within 0.03 mm (0.001 in.). Describe the method of obtaining the thickness of the adhesive layer including procedure, location of measurements, and range of measurements.

9.1.4 Conditioning procedure used,

9.1.5 Atmosphere conditions in test room,

9.1.6 Number of specimens tested,

9.1.7 Actual bonded area, and

9.1.8 Maximum, minimum, and average value of impact strength, or the cohesion, adhesion, and contact failures for the metal specimens.

## 10. Precision and Bias

10.1 Precision and bias for this test is being determined and will be available by September 2007.

## 11. Keywords

11.1 adhesive bonding; impact head; impact machine; impact strength; impact value

7.3.3 Record the percentages of cohesion, adhesion, and contact failures (Note 2). This will be based on visual inspection.

NOTE 2—Cohesion failure may be obtained by observing how much of the failure has occurred in the adhesive itself. That is, if the adhesive has adhered to the metal test pieces and no voids are visible, it represents a 100 % cohesion failure. Adhesion failure refers to the lack of adhering to metals being fastened. Contact failure refers to lack of bond lines being in contact due to uneven surfaces, poor pressure distribution, etc.

*ASTM International takes no position respecting the validity of any patent rights asserted in connection with any item mentioned in this standard. Users of this standard are expressly advised that determination of the validity of any such patent rights, and the risk of infringement of such rights, are entirely their own responsibility.*

*This standard is subject to revision at any time by the responsible technical committee and must be reviewed every five years and if not revised, either reapproved or withdrawn. Your comments are invited either for revision of this standard or for additional standards and should be addressed to ASTM International Headquarters. Your comments will receive careful consideration at a meeting of the responsible technical committee, which you may attend. If you feel that your comments have not received a fair hearing you should make your views known to the ASTM Committee on Standards, at the address shown below.*

*This standard is copyrighted by ASTM International, 100 Barr Harbor Drive, PO Box C700, West Conshohocken, PA 19428-2959, United States. Individual reprints (single or multiple copies) of this standard may be obtained by contacting ASTM at the above address or at 610-832-9585 (phone), 610-832-9555 (fax), or service@astm.org (e-mail); or through the ASTM website (www.astm.org). Permission rights to photocopy the standard may also be secured from the Copyright Clearance Center, 222 Rosewood Drive, Danvers, MA 01923, Tel: (978) 646-2600; http://www.copyright.com/*