



Standard Test Methods for Rubber Properties in Compression or Shear (Mechanical Oscillograph)¹

This standard is issued under the fixed designation D945; the number immediately following the designation indicates the year of original adoption or, in the case of revision, the year of last revision. A number in parentheses indicates the year of last reapproval. A superscript epsilon (ϵ) indicates an editorial change since the last revision or reapproval.

This standard has been approved for use by agencies of the U.S. Department of Defense.

1. Scope

1.1 These test methods cover the use of the Yerzley mechanical oscillograph for measuring mechanical properties of rubber vulcanizates in the generally small range of deformation that characterizes many technical applications. These properties include resilience, dynamic modulus, static modulus, kinetic energy, creep, and set under a given force. Measurements in compression and shear are described.^{2,3}

1.2 The test is applicable primarily, but not exclusively, to materials having static moduli at the test temperature such that forces below 2 MPa (280 psi) in compression or 1 MPa (140 psi) in shear will produce 20 % deformation, and having resilience such that at least three complete cycles are produced when obtaining the damped oscillatory curve. The range may be extended, however, by use of supplementary masses and refined methods of analysis. Materials may be compared either under comparable mean stress or mean strain conditions.

1.3 Computerized data acquisition systems and data evaluation methods for Yerzley Mechanical Oscillograph are included. The mechanical portion of the oscillograph remains the same. In the computerized type (digital data acquisition and recording), the mechanical recording mechanism has been replaced with a displacement transducer and digital data acquisition system, by which the required calculations are such that the results are available immediately and recorded in real time.

1.4 The values stated in SI units are to be regarded as the standard. The values given in parentheses are for information only.

¹ These test methods are under the jurisdiction of ASTM Committee D11 on Rubber and are the direct responsibility of Subcommittee D11.10 on Physical Testing.

Current edition approved July 1, 2016. Published July 2016. Originally approved in 1948. Last previous edition approved in 2012 as D945–06 (2012). DOI: 10.1520/D0945-16.

² A survey of some aspects of hysteresis and modulus in dynamic performance of polymers is available in a paper by Payne, A. R., "The Role of Hysteresis in Polymers," *Rubber Journal*, January 1964, p. 36.

³ One method of correlating fundamental data from the Yerzley oscillograph with dynamic tests at constant amplitude is described by Baldwin, F. P., in his paper, "Determination of the Dynamic Properties of Rubberlike Materials by Means of a Modified Yerzley Oscillograph," *The Rubber Age*, April 1950.

1.5 *This standard does not purport to address all of the safety concerns, if any, associated with its use. It is the responsibility of the user of this standard to establish appropriate safety and health practices and determine the applicability of regulatory limitations prior to use. For a specific warning see 12.14.*

2. Referenced Documents

2.1 ASTM Standards:⁴

D832 Practice for Rubber Conditioning For Low Temperature Testing

D1207 Recommended Practice for Classifying Elastomeric Compounds for Resilient Automotive Mountings (Withdrawn 1971)⁵

D4483 Practice for Evaluating Precision for Test Method Standards in the Rubber and Carbon Black Manufacturing Industries

2.2 SAE Standard:

SAE J16 Classification of Elastomer Compounds for Automotive Resilient Mountings^{6,7}

3. Terminology

3.1 Descriptions of Terms Specific to This Standard:

3.2 *effective dynamic modulus*—calculated from the formula for simple harmonic motion in a damped free oscillation. It is a composite index which includes the effect of such diverse factors as nonlinearity of stress-strain, changing molecular energies, and heat losses.

3.3 *point modulus*—ratio of total stress (force/area) to total strain (change in dimension/unstressed dimension) at one point

⁴ For referenced ASTM standards, visit the ASTM website, www.astm.org, or contact ASTM Customer Service at service@astm.org. For *Annual Book of ASTM Standards* volume information, refer to the standard's Document Summary page on the ASTM website.

⁵ The last approved version of this historical standard is referenced on www.astm.org.

⁶ Available from Society of Automotive Engineers, 400 Commonwealth Drive, Warrendale, PA 15096.

⁷ The Yerzley oscillograph was originally described in detail in the paper by Yerzley, F. L., "A Mechanical Oscillograph for Routine Tests of Rubber and Rubber-Like Materials," *Proceedings, ASTM*, Vol 39, 1939, p. 1180; also *Rubber Chemistry and Technology*, Vol XIII, No. 1, January 1940, p. 149.

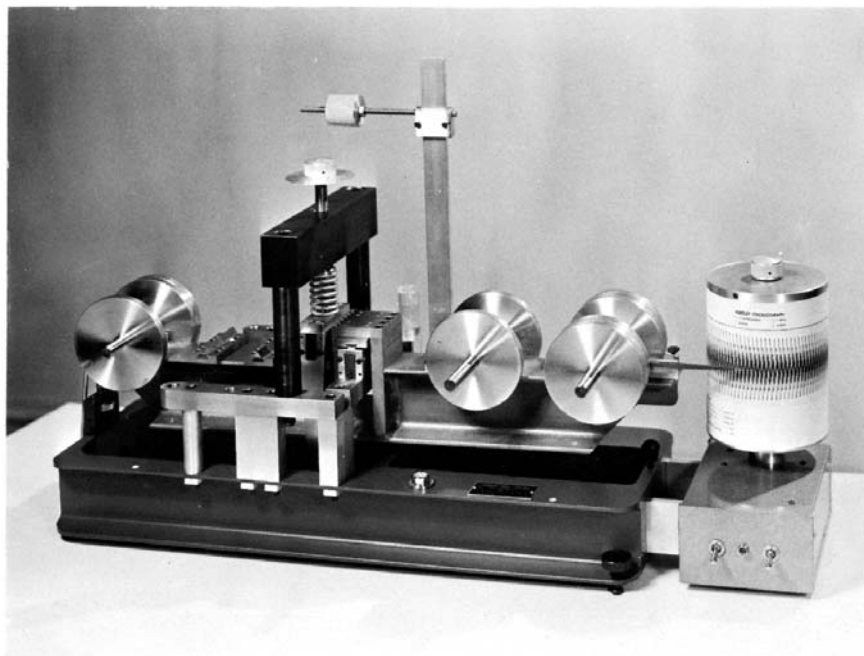

FIG. 1 Advanced Yerzley Oscillograph

of the stress-strain curve. Sometimes called the “secant modulus,” it is equal to the slope of a line from the origin to the chosen point.

3.4 *static modulus*—synonymous with “tangent modulus” and is the slope of the tangent to the stress-strain curve at a chosen point. It can provide a reference for comparison with the effective dynamic modulus at that point.

4. Summary of Test Methods

4.1 Specimens are loaded by an unbalanced lever and the resultant deflections are recorded on a chronograph. This permits calculations to be made of static modulus at any stage of a stepwise loading or unloading schedule. Creep and recovery rates, including set under prescribed conditions, can be obtained. Since the lever is supported on a knife edge, the system can be impact-loaded to produce a damped free oscillation trace. This trace yields a dynamic modulus, a resilience index, an oscillation frequency, and a measurement of stored energy.

4.2 Two test methods are described:

4.2.1 Method A employs the the original Yerzley oscillograph with the mechanical data recording equipment consisting of a chronograph and a pen attached to the end of the beam.

4.2.2 Method B introduces the displacement transducer and a data acquisition system, replacing the pen and chronograph.

5. Significance and Use

5.1 The rubber properties that are measurable by these test methods are important for the isolation and absorption of shock and vibration. These properties may be used for quality control, development and research.

5.2 Measurements in compression are influenced by specimen shape. This shape factor may be described as the ratio of the loaded surface area to the unloaded surface area. In applying data from a compression specimen, shape factor must be incorporated into the mathematical transferal to the application.

6. Apparatus

6.1 The essential features of the apparatus^{7,8} (Method A illustrated in illustrated in Fig. 1 and Fig. 2; Method B illustrated in Fig. 3) are as follows:

6.1.1 The beam shall be supported at its center by a knife-edge, *A*, and shall be so designed that a test specimen placed beneath the micrometer can be loaded by placing standard masses alternatively on front and back portions of the cross-rod, *F*, at the pen end of the beam. A second knife-edge, *B*, and a stabilizing arm, *B'*, (as shown in Fig. 2), shall be used to apply load to the test specimen and to maintain parallelism of the loading platens. Optional knife-edges, *C* and *D*, may be used to extend the range of the oscillograph.

6.1.2 *Method A*—A pen shall extend lengthwise from the beam to record deflections on the oscillogram automatically. From Fig. 2, it is apparent that the deflection of the specimen under test will be magnified by the travel of the pen in proportion to the lever ratio which will be 10:1 when the sample is on the inner test position, *B*. Therefore, a deformation

⁸ The sole source of supply of the Yerzley oscillograph known to the committee at this time is Tavdi Co., Inc., P.O. Box 298, Barrington, RI 02806, www.tavdico.com. If you are aware of alternative suppliers, please provide this information to ASTM International Headquarters. Your comments will receive careful consideration at a meeting of the responsible technical committee,¹ which you may attend.

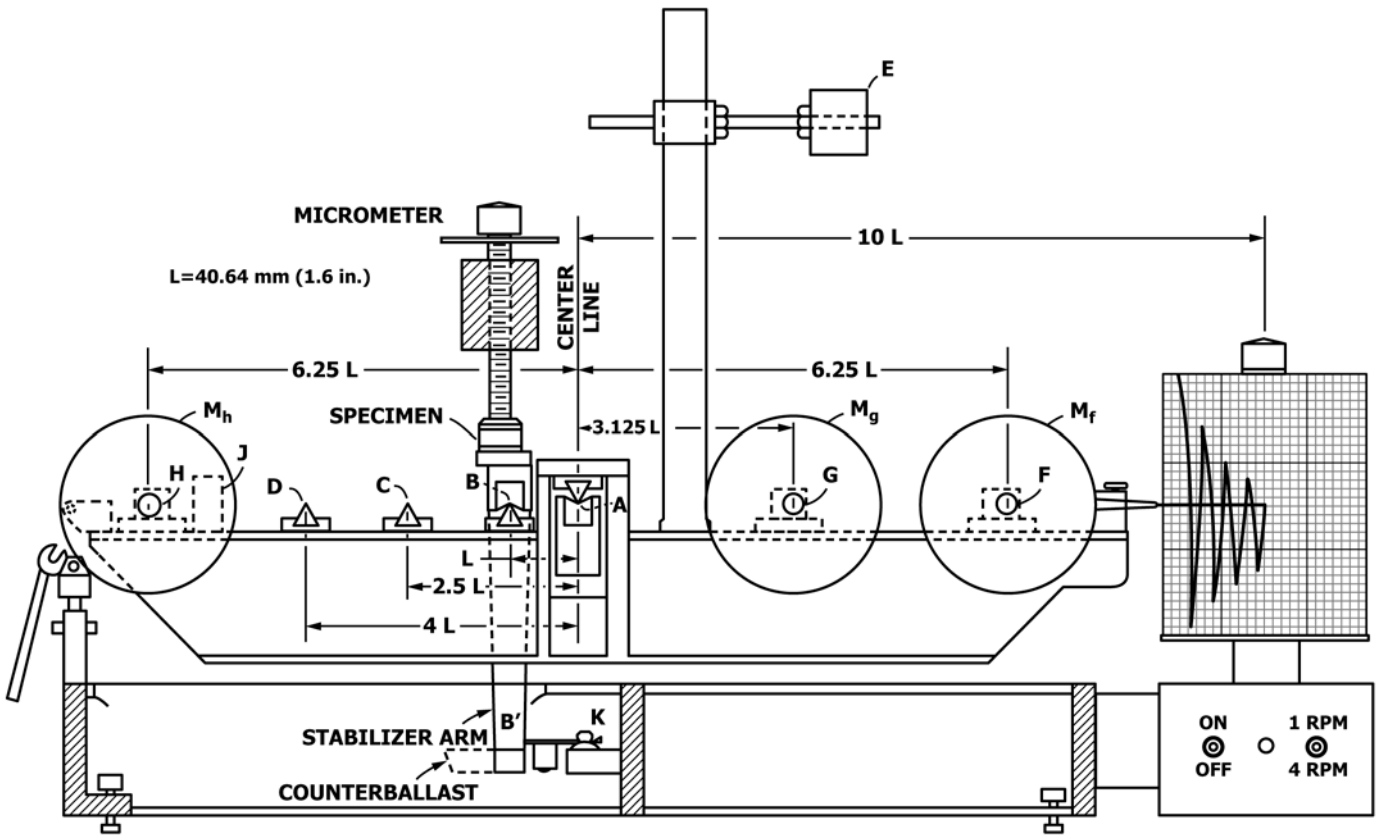

FIG. 2 Diagrammatic Sketch of Advanced Yerzley Oscillograph

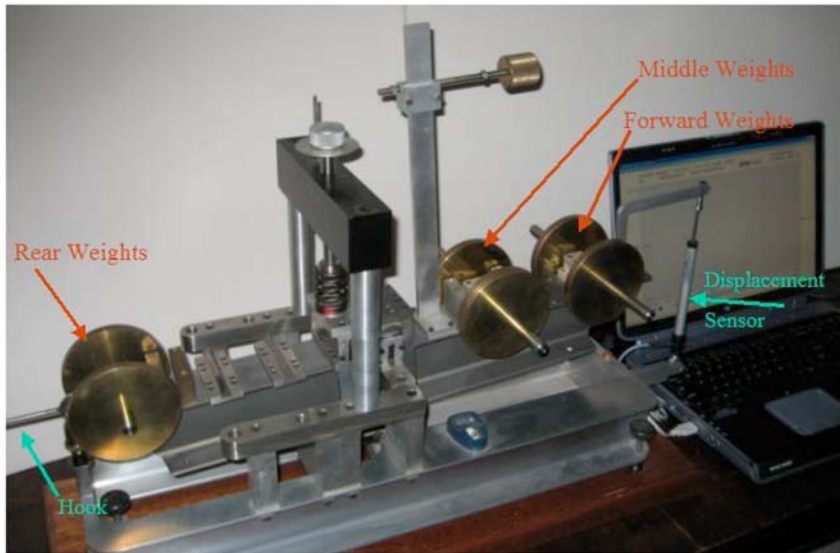

FIG. 3 Method B Yerzley Oscillograph AYO-IV With Displacement Sensor and Computer System

of 2.5 mm, for example, will be registered on the oscillogram as a vertical displacement of 25 mm.

6.1.3 *Method B*—The pen and chronograph have been replaced with a displacement transducer and a data acquisition subsystem.

6.1.4 The masses, M_F , M_G , and M_H , derive from the mass of accurately machined disks, 99.06 mm in diameter with a central hole 12.7 mm in diameter. Standard masses shall be an

integral or fractional multiple either of 641.252 g (1.41372 lb) for convenience of testing in inch-pound units or of 489.464 g for greater convenience of testing in SI units. The lever ratio for the masses is 6.25:1 for the outer mass position in reference to the inner specimen position. Using the 6.25:1 ratio, each unbalanced mass on the pen end of the beam therefore will produce the following forces on the specimen on the inner position at W_{sr} :

		Force Resulting
	Mass Value	From 6.25:1 Ratio
SI units	489.46 g	30,000 N
Inch-pound units	1.4137 lb	8.8357 lbf

6.1.5 It follows that positioning the masses on the inner mass position, M_G , will reduce the load values to half of the foregoing values.

PART I—MEASUREMENTS IN COMPRESSION

7. Test Specimens for Methods A & B

7.1 Solid Rubber Specimens:

7.1.1 At least two specimens shall be tested, except that at least three shall be required if measurement of creep is to be included. The test specimens for measurements in compression shall be right circular cylinders chosen from the following alternatives:

Shape Factor	Primary Practice	Diameter
0.390	SI units	19.5 ± 0.13 mm
0.375	Inch-pound units	0.75 ± 0.005 in.
Shape Factor	Height	Reference Area of Nominal Circle
0.390	12.5 ± 0.25 mm	300 mm ²
0.375	0.5 ± 0.010 in.	0.442 in. ²

7.1.2 The specimens may be molded, or cut from finished products and buffed to the specified dimensions. Test specimens shall be free from porosity, nicks, and cuts. (Molded specimens are preferred for dimensional accuracy and consistency.)

7.2 Cellular Test Specimens:

7.2.1 Specimens of cellular rubber shall be prepared as follows: The specimen shall be a circular cylinder cut with a circular metal die 43.70 ± 0.01 mm (1.720 ± 0.001 in.) in inside diameter for cutting the specimen in a drill press or similar device for rotating the die. The pressure applied to the die shall be sufficiently small to keep “cupping” of the cut surfaces to a minimum. In some cases, it may be necessary to freeze the cellular rubber before cutting the specimen in order to obtain parallel cut surfaces. To facilitate cutting of the specimen with smooth-cut surfaces and square edges, the die may be lubricated with water containing a wetting agent and a corrosion inhibitor such as 0.5 % sodium chromate or with silicone mold release emulsion before each specimen is cut. If a lubricant is used, the specimen shall be permitted to dry before testing. The circular bases of the specimens shall be parallel to each other and at right angles to the axis of the cylinder. The area of the circular bases is 15.00 cm² (2.323 in.²).

7.2.2 The specimen shall be not less than 6.4 mm (0.25 in.) and not more than 29 mm (1.125 in.) in thickness. If the material is too thick, it shall be sliced to the required thickness.

7.2.3 Unless otherwise specified in the detail specification, materials thinner than 6.4 mm (0.25 in.) shall be plied up to obtain the required thickness, in which case the report is to include the number of plies.

8. Conditioning for Methods A & B

8.1 Expose the test specimens and the apparatus to the temperature of the test for sufficient time to ensure temperature equilibrium. For testing at low temperatures (below room temperature), the section of the oscillograph to be enclosed shall be one of those shown by broken lines in Fig. 4. The enclosure shall be equipped with a shelf for storing test specimens and supplied with a circulating atmosphere at the temperature of test. Unless otherwise specified, the cold chamber and testing conditions shall conform to the conditions specified in Practice D832. After the test specimens have been conditioned at the test temperature, proceed in accordance with Section 9. Similar conditioning requirements apply also to tests at elevated temperatures.

9. Procedure

9.1 Procedure for Solid Rubber Specimens—Three categories of test operation are described separately under subsequent section headings to provide data for purposes as follows:

9.1.1 In 9.4 – 9.6 for initial creep and set under a given load.

9.1.2 In 9.10 – 9.12 for Yezley resilience and hysteresis, point modulus, frequency in hertz, effective dynamic modulus, and maximum impact energy absorbed at a given test load value.

9.1.3 In 9.13 – 9.17 for stepwise loading and unloading and hysteresis loop, and stresses in pascals or in pounds-force per square inch at any deformation.

9.1.4 Depending on the purpose of any test program, primary reliance may be placed on any one of the foregoing categories, on a combination of two categories, or upon all three. It is important, however, to record adequately all data required to identify the test conditions fully.

9.2 Lock the beam of the oscillograph in position by means of the release hook at the left end of the machine and remove all masses. Place the test specimen centrally on the lower platen between the grit sides of two pieces of 400 grit A sandpaper (Note 1). Adjust the micrometer until the upper platen rests snugly against the sandpaper without deforming the test specimens; then lock the micrometer by means of the set screw or lock nut. This setting can be verified as follows:

NOTE 1—Silicon carbide particles have an average size of 22 ± 2 μ m.

9.2.1 Upon disengaging the release hook the recording device (pen or transducer) end should retain its position. If the recording device (pen or transducer) drops noticeably, a change of 0.02 mm (0.001 in.) may be visibly observed, the micrometer must be readjusted downward.

9.2.2 When this adjustment is completed and verified, reengage the hook. Now apply a small downward force by hand on the recording device (pen or transducer) end of the beam. If the added force depresses the beam, the micrometer platen is too low. Readjust the micrometer until the micrometer setting is correct. Opening and closing the release hook should then have no effect on the position of the recording device (pen or transducer).

9.3 Method A—Place the graph paper on the chronograph drum and adjust its position so that the zero position of the pen point is on one of the horizontal lines of the paper. An

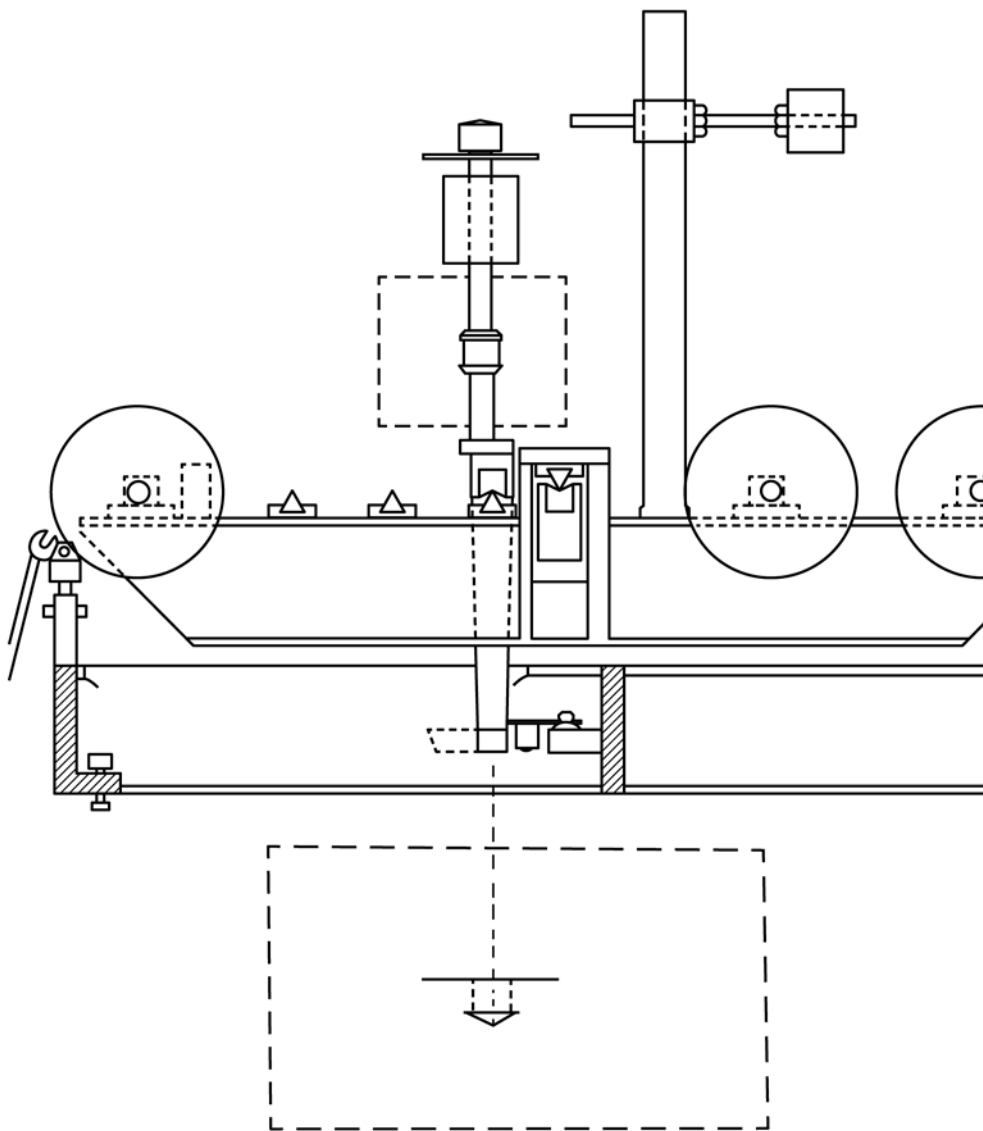

FIG. 4 Section of Oscillograph to be Enclosed for Tests at Other than Room Temperature

engineering grade of graph paper ruled in 1 in. squares and subdivided into ten equal squares per inch shall be used for measurements in inch-pound units. A quality grade of graph paper ruled in 1 cm squares subdivided in millimeter squares is preferable for measurements in SI units, although it should be noted that for 4 rpm and 1 rpm speeds of the chronograph 25.4 mm on the horizontal scale equals 1 and 4 s, respectively.

9.4 *Measurement of Initial Creep and Set*—With the beam elevated and with the hook engaged prepare to add masses to the recording device end of the beam prior to recording both the initial impact on the sample and the subsequent creep. Normally the test will be directed toward a final total deformation of 20 % plus the value of the creep. If creep of 2 % should develop, the total deformation thus would be 20 + 2 %, or 22 %. A tolerance of ± 2 % has been found convenient. Trial

and error with one sample may be used to establish the necessary number of masses. When the load value is established, proceed.

9.5 With the hook engaged, a fresh test specimen, sandpaper in position, the correct micrometer setting, and the established number of masses installed, switch on the power to the drum, to rotate at 4 rpm in order to draw the horizontal reference line at the top of the chart. This will also take up slack in the gear train driving the drum. As the drum approaches the beginning of the second revolution, change the drum speed to 1 rpm. About three small squares into the second revolution release the hook, allowing the beam to fall in an impact on the specimen, as indicated in Fig. 5. Allow the drum to rotate one or more complete revolutions beyond the end of any oscillations. Stop the motor. The creep of the sample after the end of



FIG. 5 Typical Compression Oscillogram

the oscillations will be recorded on the chart for 1 min or more. If desired, the creep for a longer time may be recorded by timing a longer period and observing the further slow downward motion of the pen as a vertical downward trace. The amount of further drift after the longer time interval can be marked by a rotation of the drum one or two small squares to the left and right by hand to form a cross on the trace line.

9.6 Set may be measured at any time by reengaging the hook to remove the load from the specimen, and then carefully turning the micrometer platen downward a measured distance into contact with the sample to close the gap caused by the short term set.

9.7 *Measurement of Initial Creep and Set with Method B*—With the beam elevated and with the hook engaged prepare to add masses to the transducer end of the beam prior to recording both the initial impact on the sample and the subsequent creep. Normally the test will be directed toward a final total deformation of 20 % plus the value of the creep. If creep of 2 % should develop, the total deformation thus would be 20 + 2 %, or 22 %. A tolerance of ± 2 % has been found convenient. Trial and error with one sample may be used to establish the necessary number of masses. When the load value is established, proceed.

9.8 With the hook engaged, a fresh test specimen, the correct micrometer setting, and the established number of masses installed, specify the “creep time” in seconds and select a data file name; then push the START button and trigger the hook.

9.9 Set may be measured at any time by reengaging the hook to remove the load from the specimen, and then carefully turning the micrometer platen downward a measured distance into contact with the sample to close the gap caused by the short term set.

9.10 *Measurement of Yezzley resilience and hysteresis, point modulus, frequency in hertz, effective dynamic modulus, and impact energy absorbed by the sample at the test load value*—Taken alone the procedure described in this section is a rapid and informative test for comparison of several properties of elastomers.

9.11 This test is the natural sequel to the previous process for creep, 9.4, or may be performed without a preceding creep and set evaluation after establishing the horizontal reference line at the top of the chart as described in 9.3. With the hook engaged, verify the position of the test specimen with 400 grit

A paper and the micrometer adjustment in firm but non-deforming contact with the specimen. With the estimated number of masses required to produce a final deformation of 20 % and with the drum stationary, disengage the hook. Allow the ensuing oscillations to die out. Note the ultimate static deformation. If the deformation is not close to 25 mm (or to 1 in.) as observed directly on the oscillogram, add or remove masses as needed to attain the required 20 % compression. Rotate the drum by hand to the left approximately one small square of the oscillogram and disengage the hook. Repeat this conditioning operation a sufficient number of times to obtain three successive lines of the same length. After the last oscillation, the pen point should indicate 20 ± 2 % deformation of the test specimen.

9.12 After obtaining three successive lines of the same length, start the chronograph with the drum rotating at a speed of 4 rpm, disengage the hook, and record a set of oscillations. If the vertical length of the first oscillation is shorter than the length of the last conditioning line, there has been excessive time between successive trials, and further conditioning as necessary shall be performed until a satisfactory test is obtained. The motor may be stopped when an adequate number of oscillations, at least three, have been recorded for a resilient composition. When the pen is at rest, rotate the drum counter-clockwise by hand and then clockwise through the horizontal time span of the oscillations to record the final static equilibrium position of the beam. Reengage the hook.

9.13 *Plotting of the load-compression characteristics of a specimen in a complete loading and unloading cycle for interpretation of its static load-bearing characteristics*—This procedure may be performed before or after the procedure of 9.10, but cannot be performed prior to the procedure of 9.4, since it would eliminate the possibility of measurement of initial creep.

9.14 Verify that all masses have been removed from the beam and that the sample is properly centered on the lower platen.

9.15 Disengage the hook and apply sufficient pressure by hand on the pen end of the beam to compress the test specimen to 30 % deformation (1.5 in. on the graph for test specimens 0.50 in. in height; 0.150 in. on the data acquisition window for test specimens 0.50 in. in height) and release. Repeat this operation at least 3 times to condition the specimen for test.

9.16 With the hook still disengaged, rotate the chronograph drum to the left clockwise, displacing the graph 4 or 5 small divisions to the left of the pen point position. Thus marking zero deflection.

9.17 Chart the loading test by placing the masses, M_F or M_G , one at a time, alternately on front and back ends of the cross rod and rotating the oscillogram exactly two 1 mm divisions (or one 0.1 in. division as appropriate to the chart used) to the left after each mass, except the last mass, has been added. After 50 % deformation has been reached, or all masses have been added, whichever comes first, chart the unloading test by rotating the oscillogram to the right exactly in a reverse number of small divisions and then removing the masses, one at a time, from alternate sides of the balance beam and rotating the oscillogram continuing exactly the same number of small divisions to the right after each mass is removed. Add and remove the masses at a uniform rate, using smooth motions. In general, the time required for making the complete loading and unloading curve, using 14 masses, ranges from 3 to 3.5 min. Masses added at the G position have half the force value compared with the F position. For most compositions, the unloading curve will terminate below the horizontal line from which the loading curve started.

9.18 *Method B*—Click on the “Stepwise Test” menu button. Enter an output file name to receive the test results. Specify a time between weight additions. Then click on the START button and follow the instructions on the screen and start adding weights. After addition of 14 weights, you will be instructed to start removing weights at the end of each time period.

9.19 When the oscillograph is not in use, leave a test specimen between the platens to prevent damage to the knife edges or to avoid personal danger in the event of accidental release of the hook.

9.20 Procedure for Cellular Material:

9.20.1 Unless otherwise specified in the detail specification, determine the compression resistance of the specimen at a compression of 25 % of its original thickness. It may be necessary to change the configuration of the machine to use knife edges C or D.

9.20.2 Allow the specimen to rest undeflected and undistorted for at least 12 h before testing for compression resistance.

9.20.3 The specimen shall be free from mechanical damage. Determine the thickness of the specimen in such a manner as to indicate the perpendicular distance between the center portion of the top and bottom faces and the value recorded to the nearest 0.05 mm (0.002 in.), as T .

9.20.4 A perforated plate 64 mm (2.5 in.) square and a circular depressor plate 45 mm (1.75 in.) in diameter fits into the micrometer for compressing the specimen.

9.20.5 Lock the balance beam of the oscillograph in position by means of the hook at the left end of the machine and remove all masses. Adjust the hook so that the static equilibrium position of the balance beam will be approximately horizontal when the specimen is under the test deflection desired.

9.20.6 Place the specimen between the perforated plate and the depressor plate, adjust the micrometer until it rests on the depressor plate without distorting the specimen, and lock the micrometer in this position by means of the available set screw or lock nut.

9.20.7 Place the graph paper on the chronograph drum and adjust the position so that the zero position of the penpoint is on one of the horizontal lines of the paper.

9.20.8 Disengage the hook and apply sufficient pressure by hand on the pen end of the beam to compress the specimen about 30 % of the required deformation in accordance with 9.20 and release. Repeat this operation 3 times to remove any trapped air from the specimen.

9.20.9 *Method A*—With the hook still disengaged, rotate the drum chart by turning the chronograph drum to the left displacing the chart 4 to 5 small divisions to the left of the pen point, thus marking zero deflection.

9.20.10 *Method A*—Obtain at least 4 deflection readings by applying approximately equal masses to the beam at intervals of 1 min and record the corresponding deflections. Select the masses applied to give deflection readings to include values on both sides of the required deflection in accordance with 9.20.1. One minute after the mass is applied, rotate the oscillogram to the left by 2 small divisions and record the deflection in divisions as D . Record the total number of mass of 641.3 g (1.4137 lb) on Rod F , Fig. 2, that produced the deflection D as n_f in accordance with 14.10.

9.20.11 *Method B*—Perform any one of the three tests, Creep & Set, Dynamic Properties and Stepwise Test.

PART B—MEASUREMENTS IN SHEAR METHOD A & B

10. Test Specimens

10.1 At least two specimens shall be tested and three shall be required if measurement of creep is to be included. The test specimens for measurements in shear shall be rectangular sandwiches consisting of two blocks of the composition to be tested adhered between parallel metal plates having dimensions as given in Fig. 6 and as follows:

Dimensions of Shear Specimens

Primary Practice	Nominal Shear Thickness, A	Nominal Shear Area, 2 by B by C
SI units	12.5 mm	600 mm ²
Inch-pound units	0.50 in.	0.884 in. ²

10.2 The sandwiches are generally molded using brass or steel plates (Fig. 6). Test specimens shall be free from porosity, nicks, and cuts.

11. Conditioning

11.1 The conditioning requirements for shear specimens are the same as that for compression (see Section 8).

12. Procedure Method A

12.1 Three categories of testing shear specimens are described separately under subsequent section headings to provide data for purposes as follows:

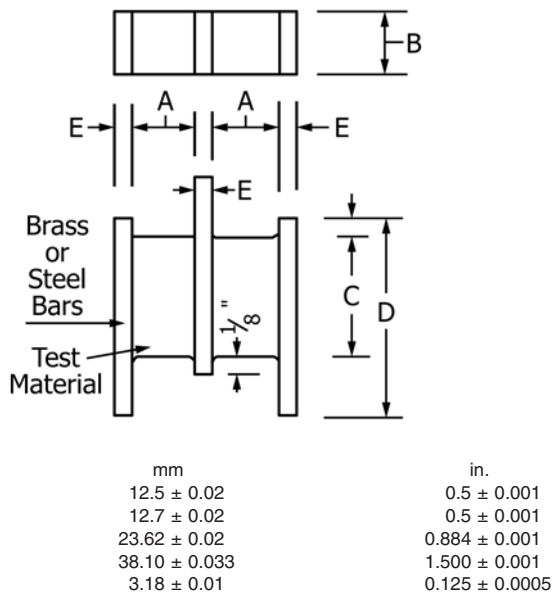

FIG. 6 Shear Test Specimen

12.2.2 When this adjustment is completed and verified, reengage the hook. Now apply a small downward force by hand on the pen end of the beam. If the added force depresses the pen, the micrometer platen is too low. Readjust the micrometer. When the micrometer setting is correct, opening and closing the release hook should have no effect on the pen position.

12.3 Place graph paper on the chronograph in accordance with 9.3.

12.4 *Measurement of Initial Creep and Set in Shear*—Proceed in accordance with 9.4, except refer to Fig. 7 instead of Fig. 5 and omit the use of sandpaper with the test specimen.

12.5 Proceed in accordance with 9.5.

12.6 Proceed in accordance with 9.6.

12.7 *Measurement of Yezzley resilience and hysteresis, point modulus, frequency in hertz, effective dynamic modulus, and impact energy absorbed by the shear sample at the test load value*—Taken alone the procedure described in this section is a rapid and informative test in shear for comparison of several properties of elastomers.

12.8 Proceed in accordance with 9.11.

12.9 Proceed in accordance with 9.12.

12.10 *Plotting of the load-compression characteristics of a shear specimen in a complete loading and unloading cycle for interpretation of its static load-bearing characteristics*—This procedure may be performed before or after the procedure of 12.7, but cannot be performed prior to the procedure of 12.4, since it would eliminate the possibility of measurement of initial creep.

12.11 Proceed in accordance with 9.14, referring to Fig. 7.

12.12 Proceed in accordance with 9.15, referring to Fig. 7.

12.13 Proceed in accordance with 9.16, referring to Fig. 7.

12.14 Chart the loading test by placing the masses, M_F , one at a time on opposite sides of the pen end of the beam and rotating the oscillogram exactly two small divisions to the left after each mass, except the last mass, has been added. After 50 % deformation is reached, or 14 masses have been added, whichever comes first, chart the unloading test by rotating the oscillogram to the right exactly two small divisions and then removing the masses, one at a time, from alternate sides of the balance beam and rotating the oscillogram exactly two small divisions to the right after each mass is removed. An equivalent alternative procedure suitable for the shear test is to add masses M_G on the cross rod, G , and to correspondingly rotate the oscillogram 1 division for each step. (**Warning**—When the oscillogram is not in use, leave a test specimen between the platens to prevent damage to the knife edges or to avoid personal danger in the event of accidental release of the hook.)

12.1.1 In 12.4 – 12.6 for initial creep and set under a given dead load.

12.1.2 In 12.7 – 12.9 for Yezzley resilience and hysteresis, point modulus, frequency in hertz, effective dynamic modulus, and maximum impact energy absorbed at a given test load value.

12.1.3 In 12.10 – 12.14 for stepwise loading and unloading, and hysteresis loop and stresses in pascals or in pounds-force per square inch at any deformation.

12.1.4 Depending on the purpose of any test program, primary reliance may be placed on any one of the foregoing categories, on a combination of two categories, or upon all three. It is important, however, to record adequately all data required to identify the test conditions fully.

12.2 Lock the beam of the oscillograph in position by means of the release hook at the left end of the machine, and remove all masses. Remove the locating disk from the lower platen. Support the metal plates of the test specimen with the end plates provided to prevent spreading of the specimen under load. Place the test specimen on the lower platen in such a manner that the ring on the end plate drops into the counterbore of the platen. Early models of the oscillograph require installation of vertical extension rods to accommodate shear specimens. Adjust the micrometer until the upper platen touches the top surface of the test specimen without deforming it; then lock the micrometer by means of the set screw or lock nut. This setting can be verified as follows.

12.2.1 Upon disengaging the release hook the pen end should retain its position. If it falls noticeably, (even 0.02 mm or 0.001 in. change can be seen), the micrometer must be readjusted downward.

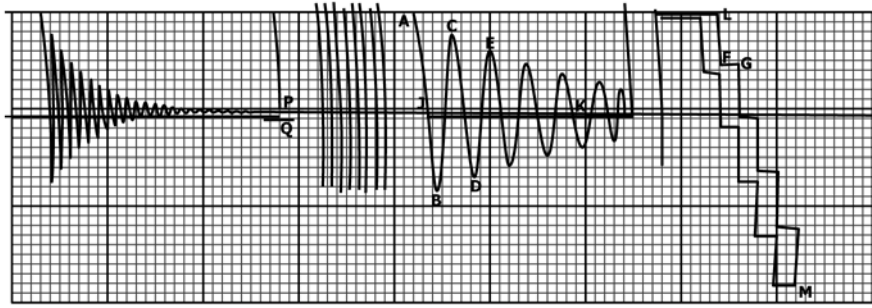

FIG. 7 Typical Shear Oscillogram

13. Procedure Method B

13.1 The test procedure for shear specimens is substantially the same as for compression specimens. Select “shear” test mode in the setup menu.

PART C—ANALYSIS OF THE OSCILLOGRAM

14. Calculation Method A

14.1 The following mechanical properties in compression or shear may be obtained directly from their respective oscillograms (Fig. 5 and Fig. 7) and shall be calculated as required in accordance with 14.2 – 14.12, using the average of the values from the two tests:

- 14.1.1 Initial creep, expressed in millimetres, inches, or percent,
- 14.1.2 Initial set, expressed in millimetres, inches, or percent,
- 14.1.3 Yerzley resilience in percent,
- 14.1.4 Yerzley hysteresis in percent,
- 14.1.5 Point modulus in megapascals or pounds-force per square inch,
- 14.1.6 Frequency in hertz,
- 14.1.7 Effective dynamic modulus in megapascals or pounds-force per square inch,
- 14.1.8 Impact energy in the rubber spring (maximum) in J/m³ or in inch-pounds per cubic inch of stock,
- 14.1.9 Plot of load versus deformation and recovery on unloading,
- 14.1.10 Stress in megapascals or in pounds-force per square inch to produce a specified deformation,
- 14.1.11 Deformation in millimetres, inches, or percent resulting from a specified load, and
- 14.1.12 Static (tangent) modulus in megapascals or pounds-force per square inch at a specified load or specified deformation.

14.2 *Creep*, expressed in millimetres, inches, or percent, under a given load after any specified time interval shall be derived from the vertical distance, PQ, on the oscillogram at that load and elapsed time.

14.3 *Set*, expressed in millimetres, inches, or percent, may be obtained on the conclusion of any test by measuring the distance between the test specimen and the upper platen after removing the load from the specimen by engaging the hook in the end of the balance beam. Make this measurement by

turning the micrometer head until the platen again rests snugly against the specimen and note the change. This distance is a measure of the set in millimetres, or in inches. It may be converted to a percentage of the original unstressed dimension of the specimen. It can be considered a qualitative measurement for comparison with related samples under approximately similar conditioning and time factors.

14.4 *Yerzley Resilience*, in percent, shall be computed from the first cycle as follows:

$$\text{Yerzley resilience, \%} = (BC/AB) \times 100 \quad (1)$$

(Note 2)

where:

- BC = vertical distance in millimetres or inches of the upstroke of the first cycle of the damped oscillatory curve, and
- AB = vertical distance in millimetres or inches of the downstroke of the first cycle of the damped oscillatory curve.

NOTE 2—A variant of the resilience calculation is required in SAE J16 and Recommended Practice D1207 as follows:

Yerzley Resilience, in percent, shall be determined as the average computed from the second and third half cycles:

$$\text{Yerzley resilience, \%} = [(CD/BC) + (DE/CD)] \times 50 \quad (2)$$

where:

- BC = vertical distance in millimetres or inches of the upstroke of the first cycle of the damped sinusoidal curve,
- CD = vertical distance in millimetres or inches of the downstroke of the second cycle of the damped sinusoidal curve, and
- DE = vertical distance in millimetres or inches of the upstroke of the second cycle of the damped sinusoidal curve.

14.5 *Yerzley Hysteresis* is the percent of impact energy lost by the sample due to internal friction. Numerically:

$$\text{Yerzley hysteresis} = (100 - \text{Yerzley resilience}), \% \quad (3)$$

14.6 *Point Modulus* is calculated by dividing the applied stress in megapascals or in pounds-force per square inch by the deformation, derived from the vertical distance AJ, expressed as a decimal fraction of the unstressed height (in compression tests) or of the unstressed thickness (in shear tests). The numerical value of point modulus is dependent among other things upon creep and set in the specimen. Determination of point modulus based upon deformation from initial sample dimension before stressing is analogous to service performance of a new finished part.

14.7 *Frequency*—Determination of the frequency in hertz shall be based on counting a convenient number of complete cycles, then measuring the horizontal distance, JK , traversed by this number of cycles, X , along the axis of the damped sinusoidal curve. When the chronograph drum rotates at N rpm and has a circumference C , calculate the frequency in hertz, f , as follows:

$$f = (NCX/60 JK) \quad (4)$$

where:

N = number of revolutions per minute of chronograph, and

C = circumference of oscillogram on drum.

X = number of complete cycles under consideration,

JK = distance along the axis of the damped sinusoidal curve for X cycles,

14.8 *Effective Dynamic Modulus*⁹ in compression for the specimen positioned at B , K_c , in megapascals based on the cylindrical specimen 19.5 mm in diameter and 12.5 mm high, shall be calculated as follows:

$$K_c = 0.996 If^2 \quad (5)$$

For the comparable shear specimen positioned at B , K_s , as follows:

$$K_s = 0.498 If^2 \quad (6)$$

where:

I = moment of inertia of the beam and masses used, $\text{kg}\cdot\text{m}^2$, (see 14.10), and

f = frequency, Hz.

Similarly, calculate K_c , in pounds-force per square inch, based on the cylindrical specimen 0.75 in. in diameter and 0.50 in. high, as follows:

$$K_c = 209.4 If^2 \quad (7)$$

For K_s :

$$K_s = 104.7 If^2 \quad (8)$$

where:

I = moment of inertia of the beam and masses used, $\text{slug}\cdot\text{ft}^2$ (see 14.10).

14.9 Tests for K_c and K_s may also be made with the test specimen at the C and D positions with suitable mathematical corrections. For example:

$$K_c = 0.996 If^2 \text{ MPa at position } B, \text{ and } K_s = 0.498 If^2 \text{ MPa} \quad (9)$$

$$K_c = 0.1594 If^2 \text{ MPa at position } C, \text{ and } K_s = 0.0797 If^2 \text{ MPa} \quad (10)$$

$$K_c = 0.0623 If^2 \text{ MPa at position } D, \text{ and } K_s = 0.0311 If^2 \text{ MPa} \quad (11)$$

14.10 *Total Moment of Inertia*, I , of the beam in $\text{kg}\cdot\text{m}^2$ or $\text{slug}\cdot\text{ft}^2$ is the sum of the moment of inertia of the beam and the moments of inertia of all added masses. This is represented as follows:

$$I = (I_B + I_F(n_F + n_H) + I_G n_G) \quad (12)$$

where:

I_B = moment of inertia of beam,

I_F = moment of inertia of a single standard mass at position F and H,

I_G = moment of inertia of a single standard mass at position G,

n_F = counted number of whole and fractional masses at position F,

n_H = counted number of whole and fractional masses at position H, and

n_G = counted number of whole and fractional masses at position G.

For convenience:

For the I -beam of the Advanced Yerzley Oscillograph:

$I = (0.1356 \text{ approx.} + 0.00850n_5 + 0.03129 n_{10}) \text{ kg}\cdot\text{m}^2$ using mass of 489.46 g

$I = (0.1000 \text{ approx.} + 0.00822n_5 + 0.03220 n_{10}) \text{ slug}\cdot\text{ft}^2$ using mass of 641.5 g

The values 0.1356 $\text{kg}\cdot\text{m}^2$ and 0.1000 $\text{slug}\cdot\text{ft}^2$ are representative values which are normally subject to replacement by exact measured values for individual beams.

For the beam having a cross section of 1 by 1 in.:

$$I = (0.0813 + 0.0307n) \text{ slug}\cdot\text{ft}^2, \text{ using mass of } 641.25 \text{ g} \quad (13)$$

For the beam having a cross section of 1 by 1.5 in.:

$$I = (0.1160 + 0.0307n) \text{ slug}\cdot\text{ft}^2, \text{ using mass of } 641.25 \text{ g} \quad (14)$$

The values 0.0813 $\text{slug}\cdot\text{ft}^2$ and 0.1160 $\text{slug}\cdot\text{ft}^2$ are accepted historically calculated values having approximate validity. The value 0.0307 $\text{slug}\cdot\text{ft}^2$ for standard masses 3.25 in. in diameter likewise has historic acceptance. When metricized, the foregoing value qualifications persist.

14.11 *Impact Energy* absorbed by the rubber spring (maximum), E_c , in joules per cubic metre of material at the end of the first one-half cycle of the damped sinusoidal curve, applied to tests of the 19.5 mm diameter cylinder, 12.5 mm high shall be calculated as follows:

$$E_c = 0.8 (n_F + 0.5n_G - n_H) (AB) \quad (15)$$

$$\times 10^3 \text{ J/m}^3, \text{ using masses of } 489.46 \text{ g}$$

For the comparable shear sample E_s :

$$E_s = 0.4 (n_F + 0.5n_G - n_H) (AB) \times 10^3 \text{ using masses of } 489.46 \text{ g} \quad (16)$$

where:

n_F , n_G , and n_H = number of masses at positions F, G, and H, respectively, and

AB = vertical distance in millimetres of the downstroke of the first cycle of the damped sinusoidal curve.

Similarly, calculate E_c , in inch-pounds per cubic inch, based on tests of the 0.75 in. diameter cylinder 0.50 in. high as follows:

$$E_c = 4(n_F + 0.5n_G - n_H)(AB), \text{ using masses of } 1.4137 \text{ lb}$$

For E_s :

$$E_s = 2(n + 0.5n_G - n_H)(AB), \text{ using masses of } 1.4137 \text{ lb}$$

⁹ For derivation of K , refer to the paper by Yerzley, F. L.

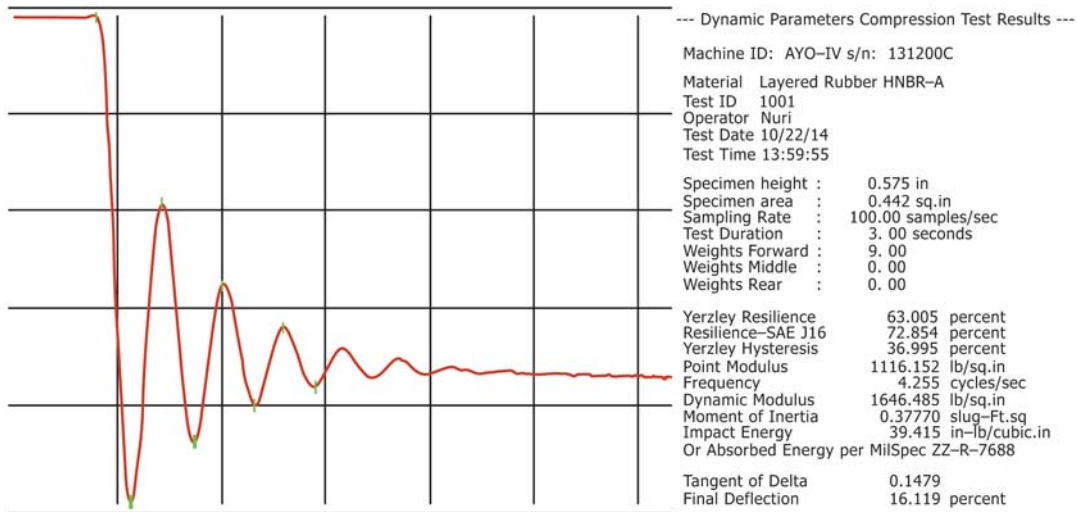

FIG. 8 Dynamic Test Results From Computer Automated Yerzley Oscillograph AYO-IV

where:

AB = vertical distance in inches of the downstroke of the first cycle of the damped-sinusoidal curve.

14.12 *Static Modulus* shall be determined from the slope of the loading curve (LM in Fig. 5 and Fig. 7) unless otherwise specified. The loading and unloading deformation curves may be obtained by projecting the horizontal lines scribed by the pen to intersect the corresponding vertical line from which the arc originated and then connecting these points of intersection, thus forming the hysteresis loop. A convenient method of determining the slope of a tangent line to curve LM and converting it into inch-pound engineering units is as follows: Place a straightedge in position to form a tangent line to curve LM at a point representing the desired static deformation, select a point where the extended tangent line crosses an intersection on the paper, and count vertically 10 squares ($dx = 20\%$ deformation) from there; then count the number of squares horizontally, dy , until the tangent line is intercepted. This number of squares on a compression oscillogram multiplied by 100 equals the static modulus in pounds-force per square inch at the selected deformation. This number of horizontal squares, dy , on a shear oscillogram multiplied by 25 equals the static modulus in pounds-force per square inch at the selected deformation.

14.13 *Interpretation of Results:*

14.13.1 Calculate the percent deflection of the specimen for each mass as follows:

$$\text{Deflection, \%} = D/T \tag{17}$$

where:

D = deflection recorded on the oscillogram for each mass, W , divisions, and

T = thickness of the original specimen, mm (in.).

14.13.2 Calculate the compressive stress of the specimen for each mass as follows:

SI Equivalents:

$$\text{Compressive stress, Pa} = n_F \times 100\,000 \tag{18}$$

Inch-Pound Equivalents:

$$\text{Compressive stress, psi} = n_F \times 20 \tag{19}$$

where:

n_F = total number of masses of 641.3 g (1.4137 lb) for each deflection, D .

14.13.3 Unless otherwise specified in the detail specifications, test three specimens from each test unit.

14.13.4 Plot the average deflection in percent of the specimens tested for each mass against the average compressive stress in pascals (or pounds-force per square inch) of the specimens tested for each mass and draw a curve through the points.

14.13.5 The compression resistance of the test unit shall be the compressive stress required to produce a 25 % deflection as read from the curve.

14.13.6 Record the compression resistance of the test unit to the nearest 0.7 kPa (0.1 psi).

14.13.7 Record the percent the specimen was compressed.

14.13.8 If a plied-up specimen is tested, record the number of plies.

15. Calculation Method B

15.1 All calculations are performed automatically upon test completion. These evaluations adhere to the methods and equations in Section 14. The results are presented as “text” files (*.txt). Raw data are also included in these files in case additional evaluations are desired. In addition to the calculations and parameters in Section 14, and additional parameter, “Tangent of Delta” is calculated. Tangent of Delta calculations are based on the analysis in the paper by Guistino et al.¹⁰ Referring to Fig. 8:

¹⁰ Guistino, J.M., Wong, C.P., and Emerson, R.J., “Rolling Resistance Prediction of Tread Compounds with a Yerzley Oscillograph,” Presented during the 136th meeting of the Rubber Division, American Chemical Society, Oct. 17-20, 1989.

TABLE 1 Type 1 Precision

NOTE 1— S_r = within laboratory standard deviation.

r = repeatability (in measurement units).

(r) = repeatability (in percent).

S_R = between laboratory standard deviation.

R = reproducibility (in measurement units).

(R) = reproducibility (in percent).

Parameter or Property	Range	Mean	Within Laboratory			Between Laboratory		
			S_r	r	(r) ^A	S_R	R	(R) ^A
Yerzley Resilience, (%)	25 to 90	57.5 ^A	0.30	0.85	1.47	1.78	5.0	8.7
Yerzley Hysteresis, (%)	10.0 to 73.5	41.8	0.25	0.71	1.70	0.94	2.66	6.4
Dynamic Modulus, (MPa)	1.9 to 3.8	2.9	0.11	0.32	11.0	0.64	1.83	63
Static Modulus, (MPa)	1.1 to 9.3	5.2	0.38	1.07	20.6	4.57	13.0	250
Impact Energy, (J/m ³)	85 to 383 (10 ³)	234 (10 ³)	0.82 (10 ³)	2.31 (10 ³)	1.0	18.7 (10 ³)	53.0 (10 ³)	22.6
Frequency, (Hz)	2.5 to 3.5	3.0	0.01	0.028	0.93	0.01	0.028	0.93
Frequency, (Hz)	3.5 to 8	5.8	0.026	0.074	1.3	0.12	0.32	5.5

^AAn estimated value using the mid-point (average) of the range.

Let p_1 = Point C - Point B

Let p_2 = Point C - Point D

$S = \log(p_1/p_2)$

Tan Delta = $2^S/\pi$

16. Report

16.1 Report the following information:

16.1.1 Identification of test specimens,

16.1.2 Date of test,

16.1.3 Temperature of test,

16.1.4 Results from calculations (Section 14), and

16.1.5 Appropriate added notes or observations.

17. Precision and Bias

17.1 This precision and bias section has been prepared in accordance with Practice D4483. Refer to Practice D4483 for terminology and other statistical calculation details.

17.2 Although prepared in format in accordance with Practice D4483, the data generated for this test method precision were obtained prior to the adoption of Practice D4483. No records exist for the original (raw) interlaboratory data. The values of within- and between-laboratory standard deviation have been used to construct Table 1.

17.3 A Type 1 (interlaboratory) precision was evaluated. Both repeatability and reproducibility are short term, a period of a few days separates replicate test results. A test result is the value as specified by this test method.

17.4 Three different materials (rubbers) were used in the interlaboratory program, these were tested in 12 laboratories on 3 different days. The results of the precision calculations for repeatability and reproducibility are given in Table 1.

17.5 The precision of this test method may be expressed in the format of the following statements which use what is called an “appropriate value” or r , R , (r), or (R), that is, that value to be used in decisions about test results (obtained with the test method) for any particular test parameter.

17.6 *Repeatability*—The repeatability, r , of this test method has been established as the appropriate value for any parameter tabulated in Table 1. Two single test results, obtained under normal test method procedures, that differ by more than this tabulated r (for any given level) must be considered as derived from different or nonidentical sample populations.

17.7 *Reproducibility*—The reproducibility, R , of this test method has been established as the appropriate value for any parameter tabulated in Table 1. Two single test results obtained in two different laboratories, under normal test method procedures, that differ by more than the tabulated R (for any given level) must be considered to have come from different or nonidentical sample populations.

17.8 Repeatability and reproducibility expressed as a percentage of the mean level, (r) and (R), have equivalent application statements as 17.6 and 17.7 for r and R . For the (r) and (R) statements, the difference in the two single test results is expressed as a percentage of the arithmetic mean of the two test results.

17.9 *Bias*—In test method terminology, bias is the difference between an average test value and the reference (or true) test property value. Reference values do not exist for this test method since the value (of the test property) is exclusively defined by the test method. Bias, therefore, cannot be determined.

18. Keywords

18.1 chronograph; compression; creep; deflection; deformation; dynamic modulus; elevated temperature; hysteresis; initial creep; kinetic energy; low temperature; mechanical oscillograph; point modulus; resilience; set; shear; static modulus; strain; stress; subnormal temperature; tangent modulus; Yerzley

ASTM International takes no position respecting the validity of any patent rights asserted in connection with any item mentioned in this standard. Users of this standard are expressly advised that determination of the validity of any such patent rights, and the risk of infringement of such rights, are entirely their own responsibility.

This standard is subject to revision at any time by the responsible technical committee and must be reviewed every five years and if not revised, either reapproved or withdrawn. Your comments are invited either for revision of this standard or for additional standards and should be addressed to ASTM International Headquarters. Your comments will receive careful consideration at a meeting of the responsible technical committee, which you may attend. If you feel that your comments have not received a fair hearing you should make your views known to the ASTM Committee on Standards, at the address shown below.

This standard is copyrighted by ASTM International, 100 Barr Harbor Drive, PO Box C700, West Conshohocken, PA 19428-2959, United States. Individual reprints (single or multiple copies) of this standard may be obtained by contacting ASTM at the above address or at 610-832-9585 (phone), 610-832-9555 (fax), or service@astm.org (e-mail); or through the ASTM website (www.astm.org). Permission rights to photocopy the standard may also be secured from the Copyright Clearance Center, 222 Rosewood Drive, Danvers, MA 01923, Tel: (978) 646-2600; <http://www.copyright.com/>