



Standard Practices for Sampling Electrical Insulating Liquids¹

This standard is issued under the fixed designation D923; the number immediately following the designation indicates the year of original adoption or, in the case of revision, the year of last revision. A number in parentheses indicates the year of last reapproval. A superscript epsilon (ε) indicates an editorial change since the last revision or reapproval.

This standard has been approved for use by agencies of the U.S. Department of Defense.

1. Scope

1.1 These practices cover sampling of new electrical insulating liquids including oils, askarels, silicones, synthetic liquids, and natural ester insulating liquids as well as those insulating liquids in service or subsequent to service in cables, transformers, circuit breakers, and other electrical apparatus. These practices apply to liquids having a viscosity of less than $6.476 \times 10^{-4} \text{ m}^2/\text{s}$ (540 cSt) at 40°C (104°F).

1.2 Representative samples of electrical insulating liquids are taken for test specimens so that the quality pertinent to their use may be determined. The quality in different portions of a given container, or the average quality of the whole bulk may be ascertained if desired.

1.3 The values stated in SI units are regarded as the standard where applicable. Inch pound units are used where there is no SI equivalent.

1.4 These practices also include special techniques and devices for sampling for dissolved gases-in-oil (DGA) (D3612), water (D1533) and particles (D6786).

1.5 For ease of use, this document has been indexed as follows:

Section Title	Section/ Paragraph
Mandatory Conditions and General Information	Section 5
Description of Sampling Devices and Containers	Section 6, Annex A1, Appendix X2
Most Frequently Used Sampling Techniques for Electrical Apparatus	
Collecting Samples from Electrical Equipment Using Bottles and Cans	Section 7, Appendix X1, Appendix X2
Collecting Samples from Electrical Equipment Using Glass Syringes (DGA and Water Analysis)	Section 8

¹ These practices are under the jurisdiction of ASTM Committee D27 on Electrical Insulating Liquids and Gases and are the direct responsibility of Subcommittee D27.07 on Physical Test.

Current edition approved Oct. 1, 2015. Published October 2015. Originally approved in 1947. Last previous edition approved in 2007 as D923 – 07. DOI: 10.1520/D0923-15.

Section Title	Section/ Paragraph
Collecting Samples from Electrical Equipment Using Stainless Steel Cylinders (DGA and Water Analysis)	Section 9
Sampling of Cans, Drums, Tank Cars, Tank Trucks and Small Electrical Equipment	
Sampling Using the Dip-Type Device (drum thief)	Section 10
Sampling Using the Pressure-Type Device	Section 11, Annex A1.1
Sampling Using the Tank Car-Type Device	Section 12, Annex A1.2
Sampling Cable Feeders	
Mandatory Conditions	Section 13
General Considerations	Section 14
Sampling Using the Manifold-Type Device	Section 15, Annex A1.3
Cleaning, Preparation, Storage, and Handling of Sampling Containers	
Storage, Packaging and Shipping of Samples	Section 17
Cleaning and Storage of Sampling Devices	Section 18
Sample Information	Section 19
Mandatory Information—Construction of Sampling Devices	Annex A1
Determination of Electrical Apparatus Temperature	Appendix X1
Sample Container Types	Appendix X2

1.6 Handle askarels containing polychlorinated biphenyls (PCBs) according to federal and local regulations existing for that country. For example, the federal regulations concerning PCBs in the United States can be found in 40 CFR Part 761.

1.7 Properly contain, package and dispose of any liquid or material resulting from the use of these practices in a manner that is in accordance with local and state regulations specific to the country in which the samples are taken.

1.8 *This standard does not purport to address all of the safety concerns, if any, associated with its use. It is the responsibility of the user of this standard to establish appropriate safety and health practices and determine the applicability of regulatory limitations prior to use.* Specific warning statements are given in 1.6, 1.7, Section 5, 10.1, 13.2, 15.2.3, Section 16, and 18.2. These practices involve close contact with the electrical insulating liquids being sampled as well as liquids and other materials used to clean the sampling tools and devices. When required, or as a matter of diligence to personal safety, use personal protective equipment (PPE).

2. Referenced Documents

2.1 *ASTM Standards:*²

D1533 Test Method for Water in Insulating Liquids by Coulometric Karl Fischer Titration

D1933 Specification for Nitrogen Gas as an Electrical Insulating Material

D3612 Test Method for Analysis of Gases Dissolved in Electrical Insulating Oil by Gas Chromatography

D4057 Practice for Manual Sampling of Petroleum and Petroleum Products

D6786 Test Method for Particle Count in Mineral Insulating Oil Using Automatic Optical Particle Counters

3. Terminology

3.1 *Definitions:*

3.1.1 *sampling*—the obtaining of that amount of a material which is adequate for making the required tests and which is representative of that portion of the material from which it is taken.

3.1.1.1 *Discussion*—In most cases the detection of contaminants that are not ordinarily dispersed uniformly through the liquid being sampled, such as water or solid particles, necessitates taking samples at specific locations where the contaminants are likely to be found. For a liquid having a relative density (specific gravity) less than one, water and some other impurities are most likely to be found on or near the bottom. In the case of a liquid having a specific gravity greater than one, some of these impurities are most likely to be found on or near the surface.

4. Significance and Use

4.1 Accurate sampling, whether of the complete contents or only parts thereof, is extremely important from the standpoint of evaluating the quality of the liquid insulant sampled. Obviously, examination of a test specimen that, because of careless sampling procedure or contamination in sampling equipment, is not directly representative, leads to erroneous conclusions concerning quality and in addition results in a loss of time, effort, and expense in securing, transporting, and testing the sample.

4.2 A study of gases and moisture contained in insulating oils from transformers and other electrical power apparatus can frequently give an early indication of abnormal behavior of the apparatus, and may indicate appropriate action be taken on the equipment before it suffers greater damage. Specific gas and moisture content can be determined from oil sampled for this purpose.

5. Mandatory Conditions and General Information

5.1 *Mandatory Conditions when Sampling Electrical Apparatus:*

5.1.1 Energized electrical apparatus being sampled must have a positive pressure at the sampling outlet, so as not to introduce an air bubble into the apparatus during the sampling process. Refer to 7.2.

5.1.2 Do not draw samples from any energized electrical equipment with a small volume of oil, especially those that require the addition of oil to maintain the electric strength of the insulation system. If the proper level or existing level can not be accurately determined do not proceed.

5.1.3 Maintain the insulating fluid within the electrical apparatus being sampled at a level that will not reduce the electric strength of the insulation system.

5.1.4 Do not sample electrical apparatus if only a drain plug is provided, as it would be difficult to control the flow.

5.1.5 Do not draw samples from energized instrument transformers such as CTs and PTs.

5.1.6 Do not draw samples from an energized switch or the cable termination compartment of network transformers.

5.2 *General Information:*

5.2.1 Take and handle samples or test specimens in such a manner as to avoid the loss or gain of properties for which they are being tested. Some tests are greatly affected by minute traces of impurities, and it is imperative that utmost precautions be taken to prevent contamination when obtaining samples. Due to the hygroscopic tendency of insulating liquids, it is important to minimize exposure to the atmosphere of the sample being taken.

5.2.2 Take a sufficient quantity of liquid as a sample to cover the requirements of the respective tests to be made. Make reference to the procedures governing these tests to ascertain the quantity of liquid for each test specimen and the number of test specimens required.

5.2.3 When samples are to be taken the temperature of the liquid should be equal to or greater than the temperature of the surrounding air in order to minimize the possibility of condensed moisture from the air being absorbed by the liquid during the sampling process, particularly in a humid atmosphere.

5.2.4 When taking samples of liquid from large storage tanks, transformers, oil-circuit breakers, gravity-fed reservoirs on oil-filled cable feeders, and other electrical equipment, the electrical equipment drain valve is usually adequate. However, when high relative humidity conditions exist and it is desired to obtain samples through a closed system, the manifold in Fig. 10 is recommended.

5.3 *General Information when Sampling Electrical Apparatus:*

5.3.1 All non-hermetically sealed equipment, filled with insulating liquid having a relative density (specific gravity) less than 1, should be provided with the sampling outlet located at the bottom of the tank so that bottom samples of the oil may be obtained.

5.3.2 All non-hermetically sealed equipment, filled with insulating liquid having a relative density (specific gravity) greater than 1, should be provided with the sampling outlet located at the top of the tank at the 25°C (77°F) liquid level so that a top sample of the liquid may be obtained.

² For referenced ASTM standards, visit the ASTM website, www.astm.org, or contact ASTM Customer Service at service@astm.org. For *Annual Book of ASTM Standards* volume information, refer to the standard's Document Summary page on the ASTM website.

5.3.3 When make-up liquid is added to any piece of electrical equipment or the liquid is filtered, allow sufficient time to lapse to allow for complete mixing before sampling in order that a representative sample is obtained.

5.3.4 If samples or test specimens must be taken when the liquid temperature is below 0°C (32°F), high water content may not be detected because of the formation of ice. Ice is a concern in both energized and de-energized electrical apparatus where insulating oil-filled compartments operate at temperatures below freezing, such as some tap changer compartments and circuit breaker tanks.

5.3.5 When retrieving samples from electrical apparatus, record the apparatus temperature (°C) along with the identification information as required by Section 19. Knowledge of the apparatus temperature (°C) at the time of sampling aids in the interpretation of results from certain tests (Refer to [Appendix X1](#)).

5.4 General Information when Sampling Liquid-Filled Tanks, Drums, Tank Trucks, Tank Cars and other Similar Containers :

5.4.1 When sampling large outdoor tanks, tank trucks, tank cars, and de-energized electrical equipment the temperature of the liquid to be sampled may be colder than the surrounding air. On such an occasion, determine and report the temperature of the liquid and air as well as the relative humidity with the results of tests. It is undesirable to collect samples that are exposed to the atmosphere when the relative humidity exceeds 50 % or under conditions of rain or snow.

5.4.2 Allow containers of new liquid to remain undisturbed for at least 8 h before samples or test specimens are taken. In some instances, such as in the case of tank cars, it is not practical to wait this prescribed length of time, and samples for routine tests may be taken after the liquid has remained undisturbed for as long a period as practicable. For referee tests, allow the full 8-h waiting period to elapse before taking samples or test specimens. Repeat samples or test specimens from tank cars may be taken without waiting an additional 8 h.

5.4.3 Unless otherwise specified, take samples of insulating liquids having a relative density (specific gravity) of less than 1 from the bottom of the liquid container. For drums, cans, small tanks, etc., design the sampling device so that the sample is obtained a distance of 3 mm from the bottom of the container, while for large tanks, tank trucks and tank cars, the distance is within 13 mm of the bottom.

5.4.4 Unless otherwise specified, take samples of insulating liquids having a relative density (specific gravity) of greater than 1 from the surface layer of the liquid.

6. Description of Sampling Devices and Containers

6.1 Devices suitable for withdrawing samples of liquid from containers, electrical equipment, cable feeders, and cable joints are described below, shown in Figs. 1–10 and the Annex, and discussed in [Appendix X1](#).

6.2 *Electrical Equipment Sampling Drain Valve or Port*—Used for taking top or bottom samples from energized or de-energized electrical apparatus. This device is especially suitable when collecting samples in a glass jar, metal can, or other suitable containers as described in this section.

6.3 *Glass Bottle*—Used for securing and storing the sample. Amber or clear (see [Notes 1 and 2](#)) and may be either glass-stoppered or fitted with screw caps having a pulp-board liner faced with tin or aluminum foil, or with a suitable oil-resistant plastic such as polyethylene, polytetrafluoroethylene (PTFE) or fluoro-elastomers. Do not use any incompatible natural or synthetic rubber materials. Must meet the requirements of Section 16. (See [Appendix X2](#).)

NOTE 1—While amber-colored glass bottles are used for storing samples as protection against light, clear glass bottles afford better visual inspection of the samples or test specimens for impurities such as water and foreign particles. Take samples that are to be subjected to referee tests in new amber-colored containers that have been cleaned as described in Section 16.

6.4 *Other Bottle or Can Containers (Note 2)*—Used for securing and storing the sample. May be constructed from a suitable oil-resistant plastic such as high-density polyethylene (HDPE) (do not use for long term storage when water content is to be determined), or metal cans such as those made from aluminum, stainless steel, other appropriate metal, or PTFE lined. Metals cans are to be constructed as fully extruded, pressed seams or welded seams. Solder seams may leave a residue that will contaminate the sample. Screw caps and closures must meet the requirements of 6.3. (See [Appendix X2](#).)

NOTE 2—It is recommended to retrieve samples for DGA and water analysis using only syringes or stainless steel cylinders. If bottles and cans are used, gases that are to be measured in the DGA analysis can easily escape from these types of containers. Alternatively, environmental gases can become entrained into the sample. Both situations can alter the results significantly.

6.5 *Glass Syringe*—The device shown in Fig. 1 must be of a suitable size terminated with a Luer lock fitting to which is attached a three-way stopcock. It is used for taking samples usually from a valve located on an insulating liquid-filled electrical apparatus. Syringes having precision ground barrels and pistons are preferred. This sampling device is the preferred mechanism for taking samples for dissolved gases-in-oil and water content. Refer to Figs. 1–4 for step by step instruction on how the device is to be used. (See [Appendix X2](#).)

6.5.1 Stopcocks used on syringes must be compatible with the insulating liquid being sampled. Polycarbonate and polystyrene for example stopcocks are not appropriate.

6.6 *Stainless Steel Sampling Cylinders*—The device shown in Fig. 5 is equipped with valves on each end may be used for sampling from a valve located on an insulating liquid-filled electrical apparatus. This is an alternative sampling device for taking samples for dissolved gases-in-oil, water content, and areas of excessive environmental contamination.

6.6.1 The materials of construction of the valves used on stainless steel cylinders must be compatible with the liquid being sampled. Valve packing materials such as Nitrile rubber, fluoro-elastomers and PTFE have been found suitable.

6.7 *Dip Type or Drum Thief*—The device shown in Fig. 6 is used for taking bottom samples from drums, storage tanks, and small de-energized electrical equipment, that are to be subjected to routine tests. It is fabricated of metal, glass or a

compatible plastic and available from most laboratory supply houses. It is not recommended for use under the following conditions:

- 6.7.1 When the samples are to be subjected to referee tests,
- 6.7.2 When the relative humidity of the atmosphere exceeds 50 %,
- 6.7.3 When the samples are to be tested for dissipation factor, resistivity, or moisture content, and
- 6.7.4 When the viscosity of the liquid to be sampled exceeds $2.28 \times 10^{-5} \text{ m}^2/5$ (21 cSt) at 40°C.

6.8 *Pressure Type*—The device shown in Figs. 7 and 8 is intended primarily for sampling drums of high-viscosity liquids. However, it is particularly suitable for obtaining samples of all electrical insulating liquids in drums where it is desired that all contact of the sample with the atmosphere is eliminated. When possible, this device should be used for obtaining samples from drums when these samples are to be subjected to referee tests.

6.9 *Tank Car Type*—The device shown in Fig. 9 is used for taking either top, middle, or bottom samples from containers of large capacity such as tank cars, tank trucks, and large storage tanks not provided with a sampling-test nipple. This device is not recommended for use under the conditions described in 6.7.1 through 6.7.4.

6.10 *Manifold*—The device shown in Fig. 10 is used for taking samples from low-pressure oil-filled cable feeders with the use of vacuum and either dry carbon dioxide gas or dry nitrogen gas. Its use is recommended when high relative humidity conditions exist and it is desired to take the samples through a closed system.

MOST FREQUENTLY USED SAMPLING TECHNIQUES FOR ELECTRICAL APPARATUS

7. Collecting Samples from Electrical Apparatus Using Bottles and Cans

7.1 Unrepresentative samples are often obtained when sampling electrical apparatus using the sampling ports mounted on drain valves without appropriate preparation. The flow allowed by these ports is not adequate to properly flush the drain valve and drain valve extension of the electrical apparatus. Since the fluid in the drain valve and extension remain quite dormant during the normal operation of the electrical apparatus, contamination with stem packing and moisture must be thoroughly flushed prior to the collection of a sample.

7.2 Check for positive pressure at a sampling outlet by placing a slug of insulating liquid in a piece of clear oil-resistant plastic tubing and attaching it to the sampling port (also known as sampling cock) located on the side of the drain valve. With the valve closed, remove the drain valve pipe plug, making sure to catch any waste and debris, and then reinstall the pipe plug to equalize the pressure. While observing the slug of insulating liquid, open the sampling port and then slowly open the drain valve. If the slug moves towards the electrical apparatus, a negative pressure exists, and sampling is to be discontinued. If the slug moves away from the electrical apparatus, a positive pressure exists, and samples can be

obtained safely. Close the drain valve and then close the drain valve port. Take extreme care in performing this procedure.

7.3 Place a flush-oil container under the main drain valve and remove the drain valve pipe plug. Wipe the inside of the valve and threads with a clean lint-free cloth making sure to remove all debris, water and plug sealing materials. Drain at least 2 L and preferably 4 L of liquid into the flush-oil container to flush the drain valve and drain valve extension. One of two procedures may then be used to prepare the drain valve for sampling.

7.3.1 *Procedure A*—Install a sample adapter on the drain valve (suitable thread size bushing adapter NPT to $\frac{3}{8}$ or $\frac{1}{4}$ in. bayonet) with a piece of oil-resistant tubing attached (see **Note 3**). Stainless steel adapters and tubing have also been found to be practical for this purpose. Flush the valve and installed sample adapter by flushing at least 1 L of liquid into the flush-oil container before collecting sample.

7.3.2 *Procedure B*—This is an alternate procedure for purging the valve when it is not practical to flush oil through the drain valve or a flush container or catch pan cannot be placed below the valve. Install the drain valve pipe plug. Attach oil resistant tubing (see **Note 3**) to the sample port on the side of the drain valve and flush at least 2 L of liquid into the flush oil container before collecting the liquid in the sample container.

NOTE 3—A new piece of oil-resistant tubing is to be used every time a sample is taken. Be aware that plastic tubing can retain water that can be imparted to the sample during sampling. For this reason, flushing the tubing along with the sample container is necessary to remove that moisture.

7.4 Adequately protect the area from which the sample is being drawn from spillage by the use of such countermeasures as plastic, oil absorbent pads and catch pans.

7.5 When collecting the sample in a glass jar, bottle or metal can, hold the sample container so that the liquid will run down the sides and limit aeration of the liquid. Partially fill the sample container 2 to 3 times and gently swirl the liquid around to warm the container in order to prevent condensation. Discard the liquid after each rinse. The flow of liquid should be gentle but not interrupted from the start of the flushing of the valve and container to the completion of the final filling of the sample container.

7.6 Obtain the sample for evaluation by allowing the liquid to flow down the sides of the container or from the bottom up, filling the container.

7.6.1 If glass sample containers are used, adequate space should remain in the container to allow for expansion of the liquid. This applies to samples that are collected at temperatures below the temperature of the sample storage area. If metal cans, bottles or cylinders are used fill the container to overflowing. Once the container has been filled to the appropriate level install the cap immediately.

7.7 Close the drain valve, remove the sample adapter, if used, and install the drain valve pipe plug with a non-hardening thread sealant. Do not reuse the tubing. Clean the sample adapter before reusing on other oil-filled compartments or apparatus. Properly label and identify the sample(s) before

leaving the site or going to the next apparatus. Dispose of any waste materials in the proper manner.

8. Collecting Samples from Electrical Apparatus Using Glass Syringes

8.1 Perform the same steps as described in 7.1 – 7.4. Attach the oil-resistant tubing to the syringe as shown in Fig. 1

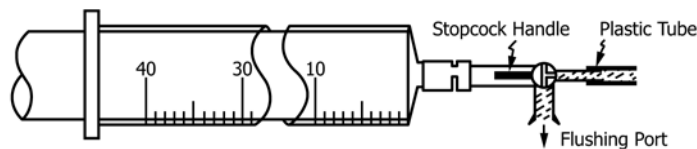

FIG. 1 Stopcock with Two Open Ports and Flushing of Stopcock

8.2 Before using a syringe make sure that the stopcock is on securely and there is no debris or obstruction in the syringe that would prevent its proper use.

8.3 The handle of the plastic stopcock always points to the closed port leaving the other two ports in open communication (Fig. 1).

8.4 Adjust the equipment drain valve or the sample port valve for a gentle flow of liquid through the tubing with the syringe stopcock open (Fig. 1) to permit flushing of the stopcock. Position the handle toward the syringe (see Note 3).

8.5 Turn the stopcock slowly to communicate with the syringe (Fig. 2, handle in line with the flushing port). Allow the

the flush container or catch pan completing the first conditioning. Perform this conditioning procedure at least one and preferably two more times.

8.5.1 If conditions warrant, the sample collection tubing may be removed from the syringe during the time the piston is depressed. In this case the flow of liquid shall continue and should be directed into the flush container. Care shall be taken

not to contaminate the syringe inlet port.

8.6 Turn the stopcock slowly to open the port to the syringe (Fig. 2 handle in line with the flushing port). Allow 10 mL of liquid to enter the syringe. Immediately close the port to the syringe (Fig. 3 handle toward the tubing).

8.7 With the syringe vertical (Fig. 3), the stopcock handle up towards the tubing, eject any air bubbles by carefully depressing the syringe piston far enough to leave 1 to 2 mL of liquid in the syringe. If all of the liquid is evacuated from the syringe, there is a greater chance of an air leak. Close the stopcock by moving the stopcock handle toward the syringe.

8.8 To eliminate any possibility that air may be entrapped in the valve, let the liquid flow through the flushing port before the valve is turned to allow the syringe to be filled.

8.9 Open the stopcock (Fig. 2), with the handle in line with flushing port. Allow the liquid pressure to push the piston back until the syringe is filled to approximately 80 % full. Do not pull the piston manually since this can result in bubble formation.

8.10 Close the stopcock (Fig. 4), with the stopcock handle



FIG. 2 Conditioning of Syringe, Stopcock Handle in Line with Flushing Port

liquid to fill the syringe to maximum full mark (shown as 40 in Fig. 2). Immediately close the port to the tubing (Fig. 3 handle

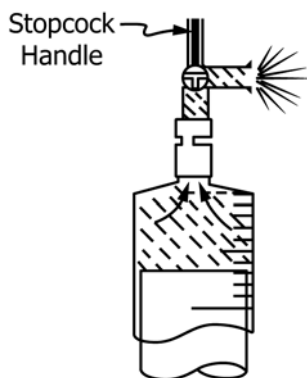

FIG. 3 Ejecting Oil from Syringe, Stopcock Handling Towards Tubing

toward tubing). Slowly depress the syringe piston (also known as plunger) until all the liquid is evacuated from the syringe to

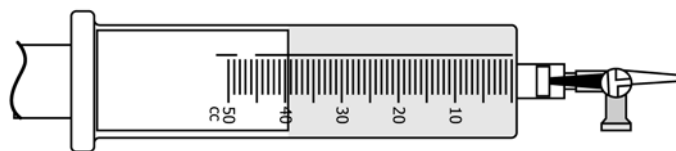

FIG. 4 Oil-Filled Syringe with Handle Towards Syringe

toward syringe. Separate the syringe from the tubing and inspect for gas bubbles. If gas is present, discharge oil with the syringe vertical (stopcock up) and obtain another sample.

8.11 Protect the syringe from sunlight after the sample is taken.

8.12 If, after a syringe has set for a period of time after the sample has been collected, and a gas bubble forms in the syringe, do not release this bubble as it contains gases from the liquid that have come out of solution but are still considered part of the sample.

8.13 Close the valve and secure the area as described in 7.7.

9. Collecting Samples from Electrical Apparatus Using Stainless Steel Cylinder

9.1 Perform the same steps as described in 7.1 – 7.4.

9.2 Hold the steel cylinder in a vertical position. Connect the oil-resistant tubing to the lower valve port on the stainless steel cylinder and connect a short piece approximately 60 cm (24 in.) of clear oil-resistant tubing to the upper valve on the steel cylinder as shown in Fig. 5 (see Note 3).

9.3 While keeping the cylinder in the vertical position, open the electrical apparatus sampling drain valve or the sample port valve. Open the lower valve on the stainless steel cylinder. Direct the short piece of plastic tubing towards the flush oil container and open the upper valve on the stainless steel cylinder. With all three valves open and the cylinder held in a vertical position (see Fig. 5), flush the cylinder. Two (2) litres of liquid should pass through the cylinder into the flush oil container.

9.4 If air bubbles are seen in the plastic tubing, the stainless steel cylinder may be tapped lightly or shaken to dislodge any bubbles inside the cylinder. Flushing with the insulating liquid should be continued until the flow out of the cylinder is free of any bubbles.

9.5 Tightly close the three valves in the following sequence: first close the upper cylinder valve; then the bottom cylinder valve; followed by the electrical apparatus drain valve or sample port valve. Remove the sample adapter if used, and reinstall the security plug with a non-hardening thread sealant.

9.6 As a final check to determine that the cylinder has been properly filled, shake the cylinder and listen for the motion of the bubbles and the splashing of liquid. If any sound is heard, the cylinder should be drained and the sampling repeated.

9.7 Close the valve and secure the area as described in 7.7.

SAMPLING OF CANS, DRUMS, TANK CARS, TANK TRUCKS, AND SMALL ELECTRICAL EQUIPMENT

10. Sampling Using the Dip-Type or Drum Thief Device (Fig. 6)

10.1 *Sampling Procedure*—Close the top hole of the device with the thumb and introduce the lower end into the liquid to be sampled to a depth of approximately 300 mm. Remove the thumb, allowing the liquid to flow into the device. Again, close the upper end with the thumb and withdraw the device, holding it in a nearly horizontal position. Shift the position of the device so that the liquid will flow back and forth in the tube, rinsing the inside surface. During this operation, take care to avoid handling any portion of the device that will be immersed in the liquid to be sampled. Discard the liquid used for rinsing. With the thumb again covering the top hole of the device, insert the lower end into the liquid at an angle so that it will come to rest on the bottom of the container at the center. Raise the device approximately 3 mm off the bottom and then release the thumb (**Warning:** see end of paragraph). When the device is filled, replace the thumb quickly, withdraw the device, and, placing the tip inside the neck close to the side of the sample container, release the thumb and allow the contents to fill the container. The free hand may be placed at a point above the liquid level to guide the tip of the device to its position on the sample container. When the container is filled, stop the flow of liquid by returning the thumb to the top hole. Do not close the bottom hole with the use of the other hand. Quickly close the sample container and attach an identifying tag. Where provided, replace the stopper in the container that was sampled. **Warning**—The standard 55 gal (208 L) oil drum is so designed

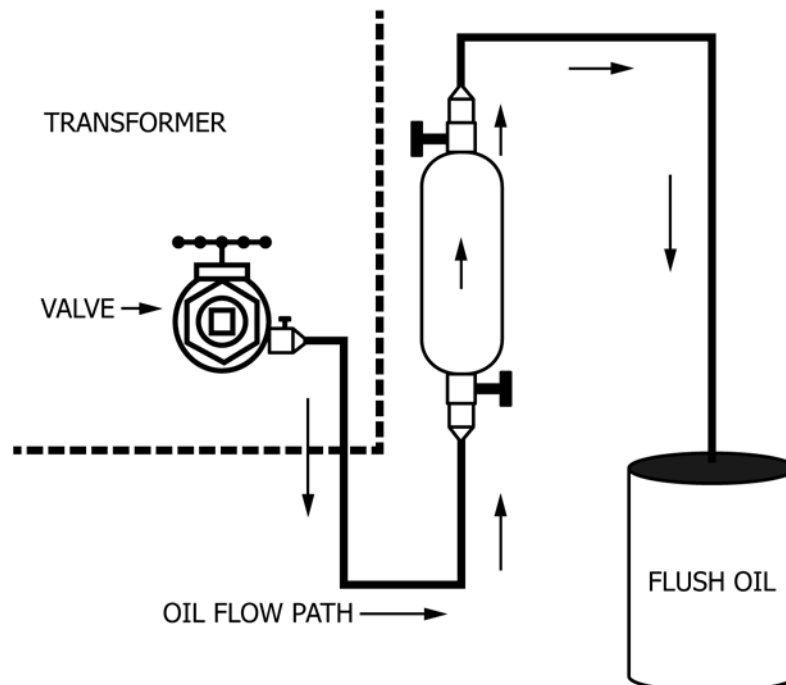

FIG. 5 Sampling with Stainless Steel Sampling Cylinder

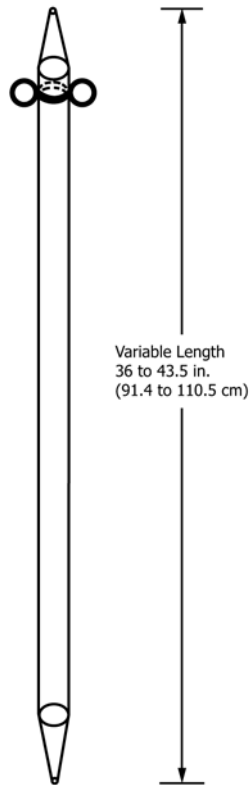

FIG. 6 Dip-Type Sampling Device

that when full and standing on end the bottom will bulge, thereby becoming concave on the inside so that at the center it is about 10 mm below that portion which is directly below the bung opening. It is essential when sampling liquid in this type of container that the dip-type device be inserted at an angle so that the bottom sample is obtained from that portion of the liquid in the center.

11. Sampling Using the Pressure-Type Device (Fig. 7 and Fig. 8)

11.1 *Apparatus*—Refer to the Annex, Section A1.1 for the construction details of this device. The following apparatus is required for the functioning of the pressure-type device:

11.1.1 *Nitrogen Gas Cylinder*—A tank of dry nitrogen gas for supplying the necessary nitrogen pressure to the liquid in the drum to be sampled. The nitrogen gas must meet the requirements prescribed in Table 1 of Specification D1933.

11.1.2 *Pressure Regulator*, to reduce the gas pressure to the desired value.

11.1.3 *Safety Valve*—A relief valve set to operate when the nitrogen pressure reaches 69 kPa (10 psi).

11.2 *Sampling Procedure*—Screw a sample bottle into the brass cap and adjust the bung on the tube so that when the bung is screwed into the drum the sampling tube will extend into the liquid to a depth of about 300 mm (see Note in Fig. 7). With the hose from the nitrogen tank clipped on the check valve, set the three-way plug cock to permit nitrogen to flow into the drum. Adjust the regulator so that the pressure is gradually increased to 34 kPa (5 psi). This will purge air from sample bottle and subsequently start the liquid to fill the bottle. When the bottle

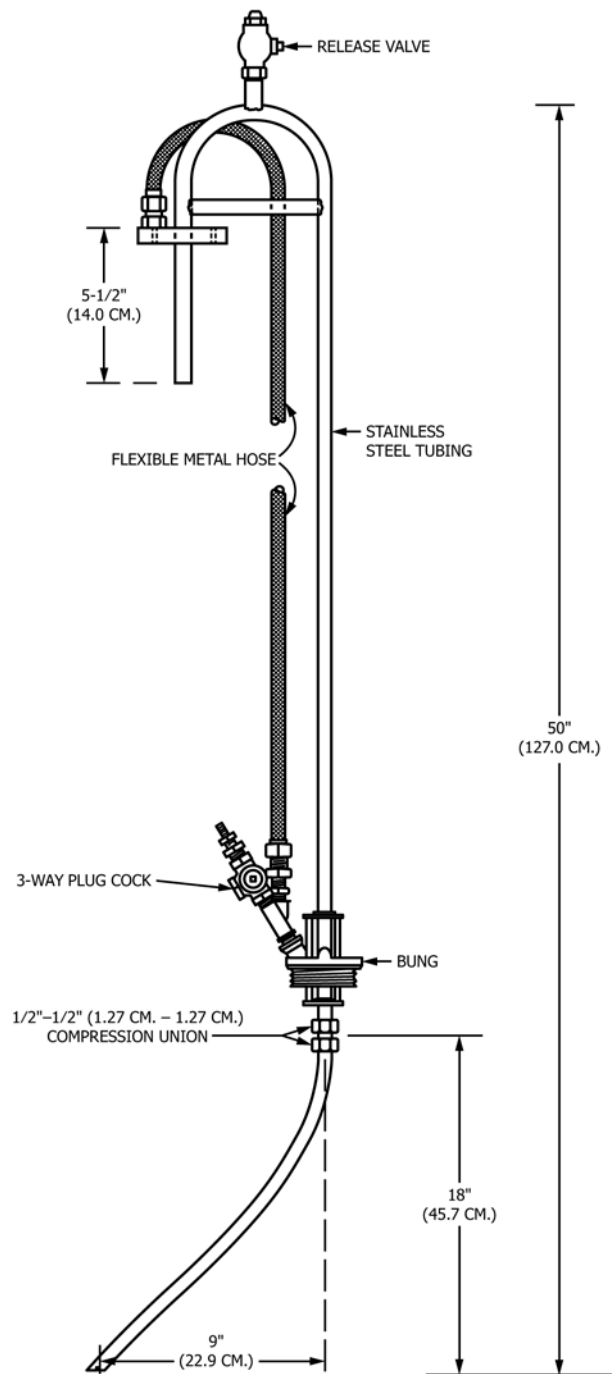

NOTE 1—The offset section of tubing at the bottom of the device shall be in the same vertical plane as the U-bend. This will permit easy alignment for obtaining a bottom sample from the center of the drum.

FIG. 7 Pressure-Type Sampling Device

is approximately 7/8 full, shut off the nitrogen supply and at the same time, vent the drum to the atmosphere by means of the three-way plug cock. Immediately vent the release valve in the top of the tube by means of the push-button valve. Unscrew the bottle and collect the drainage liquid from the tube. Discard this sample. Screw a clean sample bottle into the brass cap, push the tubing to the bottom of the drum, and set the three-way plug cock to permit nitrogen to flow into the drum.

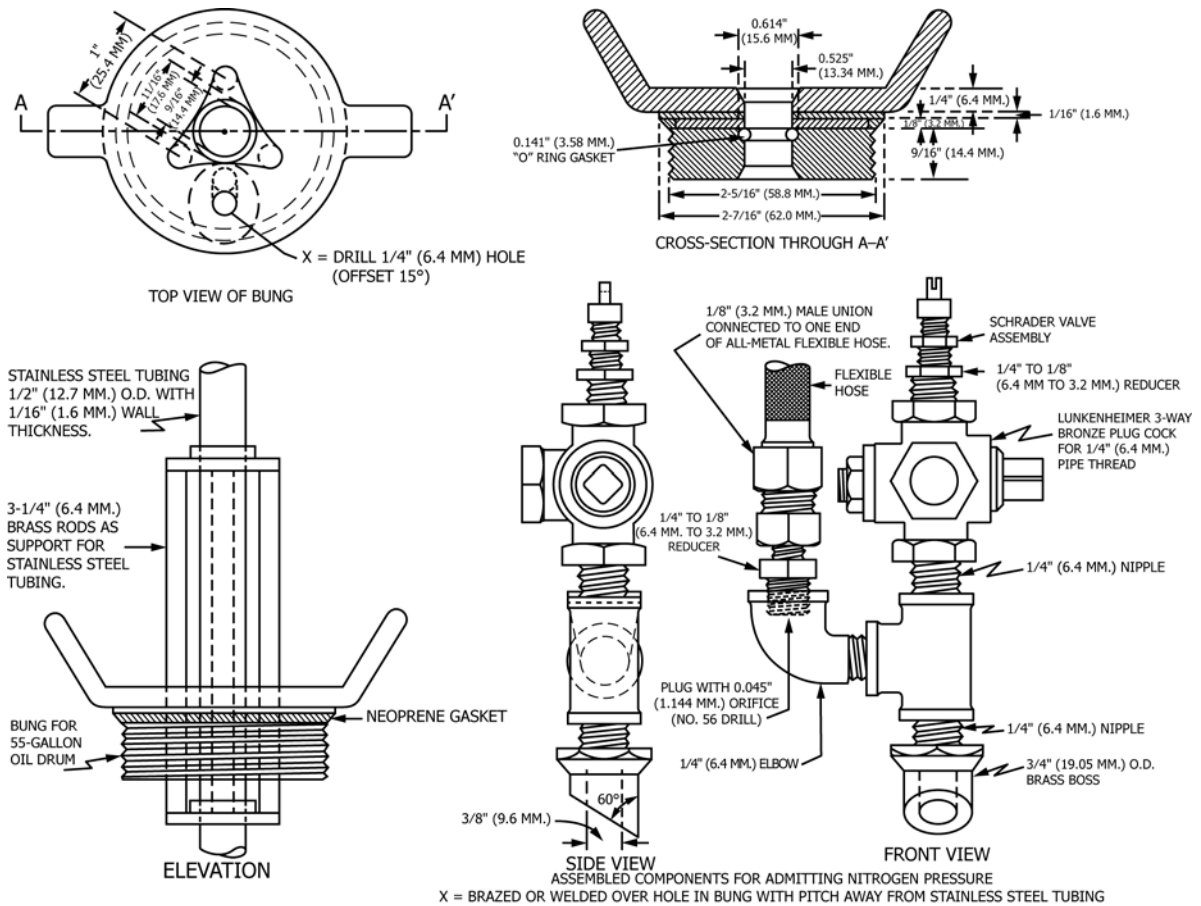

FIG. 8 Details of Bung and Fittings for Pressure-Type Sampling Devices

Restore 34 kPa (5 psi) pressure to the drum by means of the pressure regulator. This will purge the air from the sample bottle and subsequently start the liquid to fill the bottle. When the bottle is full, shut off the nitrogen supply and vent the drum to the atmosphere. Vent the release valve by means of the push-button valve, remove the sample bottle, and immediately screw the cover on tightly. Attach an identifying tag to the bottle. Withdraw the tube from the liquid and allow to drain. In sampling a shipment of new liquid in drums, the device may be inserted into the next drum and the sample taken without further cleaning or rinsing of the device, provided the previous sample showed no evidence of moisture or foreign particles.

12. Sampling Using the Tank Car-Type Device (Fig. 9)

12.1 *Apparatus*—Refer to the Annex, Section A1.2 for the construction details of this device.

12.2 *Procedure for Sampling Oil*—When sampling a tank car, tank truck, or a large storage tank of oil not provided with a sampling-test nipple, it is desirable that bottom samples as defined in Practice D4057, be taken in the area around the drain pipe. Prior to obtaining any sample, rinse the device by lowering it into the tank of oil approximately 300 mm beneath the surface, and with a cord attached to the plunger raise it so that liquid will fill the reservoir. When filled, release the plunger, withdraw the device, and discard the contents; then lower the device gently until it rests on the bottom of the tank,

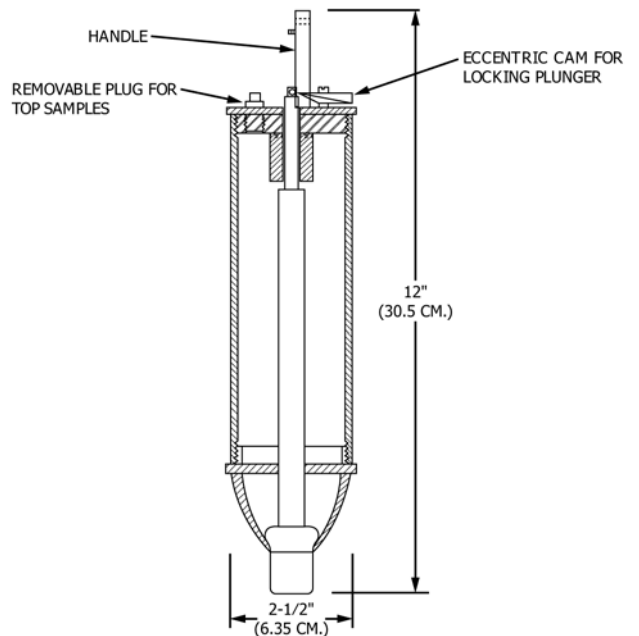

FIG. 9 Tank Car-Type Sampling Device

taking care that it is held in an upright position. The plunger will have recessed, and filling of the device will be evidenced by bubbles of air rising to the surface of the oil. When the

bubbles cease to rise, the device is filled. Withdraw the device. In emptying the device into the sample container, allow the oil to flow against the side of the container. Repeat the operation at points on an imaginary circle around the drain pipe until the desired number of samples have been obtained. When it is desired to obtain samples at some specified depth, raise the plunger by means of the attached cord and when filled, as indicated by the cessation of air bubbles rising to the surface, withdraw the device. Empty the device into the sample container, observing the precautions previously mentioned. It is suggested that twice the number of samples or test specimens to be subjected to the desired tests be taken and half the number held in abeyance pending the possibility of additional tests being necessary, in which case a revisit to the location to sample again would be avoided. Attach an identifying tag to each sample bottle as soon as it has been filled.

SAMPLING CABLE FEEDERS

13. Mandatory Conditions

13.1 Contaminated liquid may be present in any piece of sealed equipment, cable feeder, or cable joint. In order that contaminated liquid is not discarded, do not draw off any liquid prior to taking a sample nor rinse the sampling device with liquid drawn from the sample source. Exception to the conditions will apply where a connecting line exists between the sampling point and the liquid source to be sampled. In this case, withdraw and discard a quantity of liquid approximately equal to the volume in the connecting line.

13.2 **Warning**—In the sampling of oil from a high-pressure pipe-type cable feeder, exercise extreme caution when opening the valve. First connect the sampling device with the bottle in place to the sampling outlet and gradually open the valve to permit a flow of oil into the sample bottle without undue force.

14. General Considerations

14.1 Specify the location at which sampling outlets are to be installed on liquid-filled cable feeders and joints whenever sampling is contemplated and indicate on the design drawings so that samples will always be obtained at the same locations

whenever sampling is repeated. In this way the history of the insulating liquid as a function of time will be comparable, since samples will always be obtained at specific locations.

15. Sampling Using the Manifold-Type Device (Fig. 10)

15.1 *Apparatus*—Refer to the Annex, Section A1.3 for the construction details of this device.

15.2 Sampling Procedure:

15.2.1 If there is no reservoir at the cable end remote from the sampling location, connect a reservoir of adequate liquid and pressure capacity at the remote end. Close the valve on the reservoir at the sampling end to ensure minimum dilution of the sample with reservoir liquid.

15.2.2 Connect the manifold with the flexible metal hose to the sampling outlet and connect the vacuum and gas lines.

15.2.3 Open the sampling outlet valve and flush the manifold by opening valves 1, 2, and 7. After flushing the manifold, close valves 2 and 7 and continue draining liquid through valve 1 until a quantity corresponding to the volume of the tubing between valve 1 and the location of the liquid to be sampled in the joint or termination, has been drawn off. Close valve 1.

Warning—Regulate the flow of liquid so that a positive pressure will be maintained in the oil system. For this purpose install a gauge between valve 1 and the sampling outlet valve (see Fig. 5). The pressure as indicated on the gauge, with valve 3 open, shall be not less than 14 kPa (2 psi) if the gauge is installed at the same elevation as the sampling outlet valve. If the gauge is installed at a lower elevation than the valve, the minimum allowable pressure shall be increased by 2.8 kPa (0.4 psi) per foot of difference in elevation.

15.2.4 Screw clean sample containers into the metal caps. Open valves 4 and 5 and apply to the sample containers a vacuum of not less than 133 Pa (1 mm Hg) for 10 min. Close valves 4 and 5.

15.2.5 Open valve 1 and fill container No. 1 to 13 mm from the top. Close valve 1. Open valve 2 and repeat the same procedure for container No. 2. Close valve 2.

15.2.6 Break the vacuum with gas by opening valves 4 and 6. Remove the containers from the manifold, close valves 4 and 6, and seal and identify the sample containers.

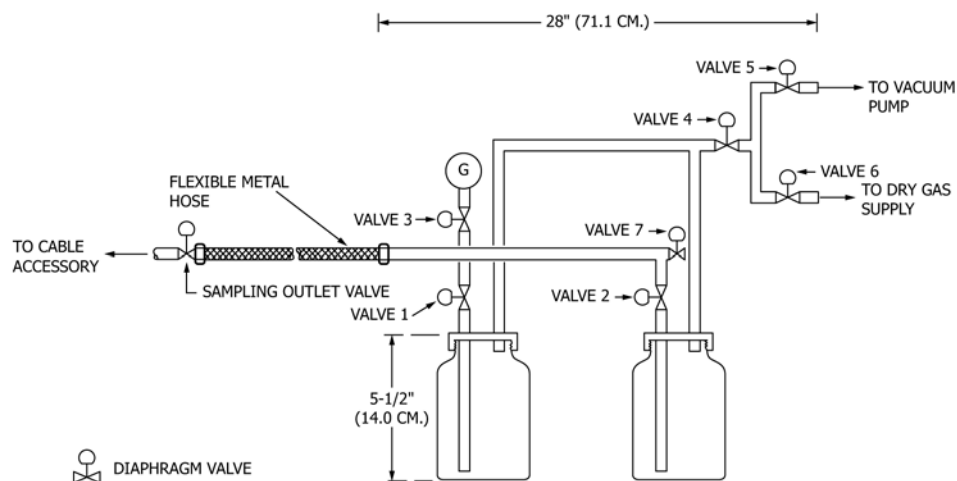

FIG. 10 Apparatus for Sampling Oil from Low-Pressure Filled Cable with Use of Vacuum and Dry Gas

15.2.7 Disconnect the manifold from the sampling outlet and restore the cable liquid system to normal.

16. Cleaning, Preparation, Storage and Handling of Sampling Containers

16.1 Because of the inherent susceptibility of most insulating liquids to contaminating influences of the most minute nature, the cleanliness of the sample container is of paramount importance for ensuring that the sample obtained is representative of the bulk from which it was taken. For these reasons, it is essential that the procedures outlined in the following paragraphs are strictly observed.

16.2 *Cleaning and Preparation of Bottles and Cans:*

16.2.1 If containers have been previously used for sampling liquids and are to be cleaned for reuse, thoroughly rinse the container with Stoddard solvent, precipitation naphtha, or other suitable cleaning agent that completely dissolves the liquid residue, and then subject to a soap and water cleaning and water rinse. If a water-soluble cleaning agent such as trisodium phosphate is used, rinse thoroughly with tap water. Invert the containers and drain for 10 min; then immerse in a 10 % solution of non-chromate acid-based cleaner for not less than 1 h. At the end of this period rinse with tap water, then with distilled water, and dry in an upright position in a forced-draft oven at 110°C for not less than 1 h. In the case of containers that have not been previously used, the initial cleaning may be omitted and the containers placed immediately in the non-chromate solution followed by the rinsing and drying outlined above.

16.2.2 Clean and dry glass stoppers in a manner similar to that of the container in which they are to be used. Do not reuse covers having vinyl liners. Dry new covers with vinyl liners in an oven at 110°C for not less than 30 min immediately prior to being placed on the bottles.

16.2.3 When the drying periods for the bottles and covers or stoppers is complete, lightly stopper each bottle immediately as it is removed from the oven, taking care not to touch the lip of the container or that portion of the stopper or cover likely to come in contact with the sample.

16.2.4 In most cases, these cleaning procedures are time consuming and no longer economical and thus rarely used. The majority of sample containers are now purchased directly from the manufacturer or supplier for their intended purpose. The user must make sure that these sample containers have been cleaned or processed in a manner which meets or exceeds the requirements in 16.2.1 – 16.2.3.

16.2.5 Particle-free bottles must be prepared in such a manner as to remove as many particles as possible. Although there are no established guidelines as to how to adequately prepare a particle free bottle, most bottle manufacturers use an ionization and vacuum process to remove the particles and then they are fitted with a suitable non-shedding threaded capped. Other particle removing processes can also be used. The bottles shall meet the cleanliness criteria of contributing less than 1 % of the total particles expected in the cleanest sample. If purchased from a manufacturer or supplier, and the bottle arrives uncapped, or if the cap falls off, then the bottle can no longer be considered particle free.

16.3 *Cleaning and Preparation of Syringes and Stainless Steel Cylinders:*

16.3.1 Various methods can be used to clean these types of devices. The most common are to rinse in a series of suitable solvents or by using a degreasing apparatus. Whatever method is used, the liquid insulating residue must be removed from the syringe, stopcock and cylinders and dried in a manner so that no residue from the cleaning process is left behind. These devices can be stored either horizontally or vertically after being cleaned and dried. The stopcock valve on the glass syringe is to be closed with a slight gas space in the syringe to allow for expansion and contraction of the syringe barrel and plunger.

16.3.2 Close both valves on the stainless steel sampling cylinder after it is cleaned and dried. It is advisable to maintain a slight positive pressure inside the cylinder with a dry inert gas such as nitrogen or argon. When this is done make sure the cylinder is appropriately labeled with this information.

16.4 *Storage and Handling of Empty Containers:*

16.4.1 Keep containers that are to be stored for future use in a warm, dry storage cabinet. Store all empty sample containers in such manner that the possibility of their being contaminated is eliminated. Keep containers sealed until immediately before sampling to prevent contamination by dirt or moisture.

17. Storage, Packaging and Shipping of Samples

17.1 *Storage of Samples:*

17.1.1 Store all sample containers with samples or test specimens in them in such manner that the possibility of their being contaminated is eliminated. Seal containers as soon as the sample or test specimen is taken to prevent contamination by dirt or moisture. As soon as samples are taken, properly identify them. To prevent breakage, handle the sample container after filling with care during transportation and storage. Store samples in the dark when clear bottles are used. Amber-colored bottles and metal cylinders, cans or bottles provide good protection against degradation of the sample by sunlight.

17.2 *Packaging and Shipping of Samples :*

17.2.1 Carefully package each container to avoid spillage and then forward to the laboratory for analysis. Do not allow the oil to be exposed to sunlight as this promotes photodegradation. Convenient cardboard and foam cartons for storing and transporting syringes can be obtained. Samples should be forwarded to the laboratory as quickly as possible as prolonged storage can result in changes in the properties of the insulating liquid sample.

18. Cleaning and Storage of Sampling Devices

18.1 *Cleaning the Dip-Type (Drum Thief) Device*—Refer to Fig. 6. Clean the device by rinsing the inside and outside surfaces with Stoddard solvent, or other suitable solvent. Place a small funnel in one end of the tube, place the forefinger of one hand over the other opening, and partially fill the device with solvent. Remove the funnel, cover the opening with the forefinger of the other hand and flush the tube by agitating the solvent back and forth. Empty the tube, flush the outside surface with solvent, and take care after rinsing not to touch any portion of the tube that will be immersed in the liquid when

the sample is being taken. It is advisable to use nitrile or polyethylene gloves when performing this procedure.

18.2 *Cleaning the Pressure-Type Device*— Refer to **Fig. 7**. Invert the device, hold it in a perpendicular position, and place the U-bend in a pail or similar container. Insert a small funnel into the top end of the tubing, and thoroughly rinse the inside surface of the tubing by flushing it several times with Stoddard solvent or other suitable solvent. Drain the solvent from the tubing and pour more solvent over the outside surface of those parts of the tubing that will be immersed in the liquid while the sample is being taken. When this operation is completed, exercise care not to touch any part of the sampling tube that will be immersed in the liquid when obtaining a sample. **Warning**—Before proceeding to use this method, inspect the area in which the drums to be sampled are located to be positive there is adequate ventilation, preventing a concentration of the nitrogen gas which is dissipated during the sampling operation. Comply with OSHA regulations concerning confined space.

18.3 *Cleaning the Tank Car-Type Device*— Refer to **Fig. 9**. Holding the device suspended by its handle, thoroughly rinse the inside surface and then the outside surface with Stoddard solvent or other suitable solvent. When the liquid to be sampled is askarel, the solvent used for rinsing the device must not be from a petroleum base.

18.4 *Cleaning the Manifold-Type Device*— Refer to **Fig. 10**. With valve 3 closed and all other valves open, rinse the inside surface of the manifold thoroughly with Stoddard solvent or other suitable solvent and also the outside surfaces of the tubing that extends into the sample bottles. Screw two sample

bottles into the caps, close valves 5 and 7, and purge the manifold with dry gas for approximately 15 s. Remove the sample bottles and do not use them for obtaining samples.

18.5 *Storage of Sampling Devices* :

18.5.1 When not in use, clean sampling devices as indicated in **18.1 – 18.4**, and keep at all times in a vertical position in a dry, dust-free cabinet or a clean sealed plastic bag. Provide the cabinet with a rack having a suitable drainage receptacle at the base.

18.5.2 Attempt to store all sampling devices in a room having low humidity.

19. Sample Information

19.1 Attach a tag, label or otherwise mark each sample container so that it can be properly identified.

19.2 At a minimum, include the following information:

19.2.1 Serial or identification number,

19.2.2 Date of sampling, and

19.2.3 Temperature of oil reading and location where it was retrieved (**Note 4**).

NOTE 4—There is debate as to the best place from which to retrieve the temperature of the apparatus. The table in **Appendix X1** provides a brief description of advantages and disadvantages of each measuring technique but is by no means meant to be exhaustive.

20. Keywords

20.1 bottles; cans; dissolved-gas-in oil; dissolved gases-in-oil; electrical insulating liquid; particle; sampling; sampling electrical apparatus; sampling procedures; syringes; water content

ANNEX

(Mandatory Information)

A1. CONSTRUCTION OF DEVICES USED FOR SAMPLING OF ELECTRICAL INSULATING LIQUIDS

A1.1 Pressure-Type

A1.1.1 Construct the device as shown in **Figs. 7 and 8** of the following components:

A1.1.1.1 *Stainless Steel Tubing*, ½ in. in outside diameter with ¼ in. wall thickness.

A1.1.1.2 *Brass Cap*, having threads machined to receive a standard 70/400 wide mouth bottle 2 ¾ in. in inside diameter of about 475 cc (16 oz) or about 950 cc (32 oz) capacity.

A1.1.1.3 *BUNA-N Ring Gasket*, ⅛ in. thick and ¾ in. wide, cut to fit snugly around the inside of the brass cap to provide a seal between the rim of the sample bottle and the inside surface of the cap. Viton may also be used.

A1.1.1.4 *Release Valve*,³ normally closed, pushbutton, mounted at the apex of the inverted U-bend in the stainless

steel tubing for venting the oil line and thereby preventing the oil from siphoning back into the drum when the nitrogen pressure is released. (The nozzle on the outlet end of valve has been shortened.)

A1.1.1.5 *Brass Bung*, machined to the dimensions and with threads to fit a 55 gal (208 L) drum used for packaging oil. Details of the construction of this bung as well as the fittings assembled on it to admit nitrogen gas into the drum and sample bottle are shown in **Fig. 8**.

A1.1.1.6 *All Metal Flexible Hose*, 1.5 m (5 ft) length, ⅜ in. size, equipped on both ends with a compression male union. Connect one end of this hose over a ⅛ in. diameter hole in the brass bottle cap and the other end into the bushing in the elbow connected in the nitrogen supply line. Insert an orifice 0.045 in. in diameter (No. 56 drill) into the bushing to reduce the flow of gas into the bottle.

A1.1.1.7 *Bronze Plug Cock*, three-way for threaded ¼ in. pipe, with cock levers.

³ A Schrader Valve, Catalog No. 7184C, has been found satisfactory for this purpose.

A1.1.1.8 Provide the end of the stainless steel tubing that is to be inserted into the drum with three notches 120° apart and each not less than 3 mm deep.

A1.2 Tank Car-Type

A1.2.1 Construct the device (also known as a Bacon Bomb) as shown in Fig. 9, in both about 475 cc (1 pt) and about 950 cc (1 qt) capacities with the following features:

A1.2.1.1 Design the plunger so that, when recessed, the distance it extends through the bottom of the reservoir is within 13 mm.

A1.2.1.2 Provide an eccentric cam for locking the plunger when desired.

A1.2.1.3 Provide a 3/8 in. threaded hole in the flat top of the device with a threaded plug which can be removed when top samples are taken.

A1.2.1.4 Sufficiently weight the device so that it will sink readily when lowered into liquid having a specific gravity of 1.6.

A1.2.1.5 The surfaces of the device must be smooth and properly machined to facilitate easy cleaning.

A1.3 Manifold

A1.3.1 Construct the device as shown in Fig. 10 of the following components:

A1.3.1.1 *Brass Piping*, NPS 1/4.

A1.3.1.2 *Brass Caps*, two, having threads machined to receive standard 70/4000 wide mouth bottles 2 3/8 in. in inside diameter, of about 475 cc (16 oz) or 950 cc (32 oz) capacity.

A1.3.1.3 *BUNA-N Ring Gaskets*, two, 1/8 in. thick, 3/8 in. wide, cut to fit snugly around the inside of the brass cap to provide a seal between the rim of the sample bottle and the inside surface of the cap.

A1.3.1.4 *Diaphragm Valve*, eight, 1/4 in. having oil compatible wetted parts.

A1.3.1.5 *All Metal Flexible Hose*, 3/8 in. provided with suitable fittings at each end for connection to the manifold and sampling outlet on the cable accessory respectively.

A1.3.1.6 *Compound Gauge*, capable of measuring pressures between 7 and 21 kPa (1 and 3 psi).

APPENDIXES

(Nonmandatory Information)

X1. DETERMINATION OF ELECTRICAL APPARATUS TEMPERATURE

X1.1 There is debate as to the best place from which to retrieve the temperature of the electrical apparatus. The table below provides some general guidelines with advantages and disadvantages list but the list is by no means meant to be exhaustive.

Location of Temperature Retrieval	Measurement Type	Advantages and Disadvantages
Apparatus Top Oil Temperature Gauge	Direct	<p><u>Advantages</u> The thermowell of the gauge is installed directly into the oil of the apparatus thus eliminating external influences.</p> <p><u>Disadvantages</u> Gauges need to be kept in calibration. Very small transformers and OCBs usually do not have temperature gauges. Convection cooled transformers can have a large temperature differential between the top and bottom of the apparatus.</p>
Temperature of sample as it exits the sampling valve (thermometers)	Indirect	<p><u>Advantages</u> Have the ability to always retrieve a temperature no matter what apparatus is being sampled.</p> <p><u>Disadvantages</u> The thermometer used may be out of calibration. The drain valve is a large thermal sink and most often will cool the exiting oil from 2 to 25°C thus not representing the bulk oil temperature. There can be a response time issue with the use of a thermometer and the oil may even cool down more before the reading stabilizes.</p>
Infrared point and shoot thermometer (small handheld units)	Indirect	<p><u>Advantages</u> Have the ability to always retrieve a temperature no matter what apparatus being sampled. Depending on the model, various features are available including a scanning type that can record the temperature from the top of the tank to the bottom.</p> <p><u>Disadvantages</u> Accuracy of the measurement is based on how close the user is to the apparatus being surveyed. The emissivity of the apparatus material of construction and color add additional error to the measurement.</p>

X2. SAMPLE CONTAINER TYPES

X2.1 The table below provides information on the appropriate sample containers that can be used for storing insulating liquids. The table also provides some common advantages and disadvantages but is by no means meant to be exhaustive. A sample container must be large enough to hold the required volume of liquid for the tests to be conducted, does not impart any contamination to the sample and prevents property changes in the insulating liquid.

Container Type	Advantages	Disadvantages
Glass Syringe	Best container for DGA and water measurements, affords visual inspection of sample, effectively keeps out environmental contaminants.	Limited volume, breakage, sample can be susceptible to photodegradation if not protected from the light.
Stainless Steel Sampling Cylinder	Extremely durable container, effectively keeps out environmental contaminants, also a good container for DGA and water measurements.	Cannot view contents and thus gas bubbles are sometimes lost during DGA analysis, heavy, valves can leak without the user knowing. Heavy container to ship.
Dark High Density Polyethylene (HDPE) Bottle	Very durable and lightweight container, sample protected from photodegradation, good container for regular oil quality tests and furanic compounds.	Cannot view contents, not good for water content measurements as the plastic walls are permeable. Ingress of water may impact other tests as well such as dielectric strength.
Opaque High Density Polyethylene (HDPE) Bottle	Very durable and lightweight container, good container for regular oil quality tests and furanic compounds.	Can somewhat view contents, not good for water content measurements as the plastic walls are permeable, sample can be susceptible to photodegradation if not protected from the light. Ingress of water may impact other tests as well such as dielectric strength.
Amber Glass Bottle	Excellent bottle for regular oil quality tests, sample protected from photodegradation, the water content of the samples is usually not impacted.	Breakage, limited viewing of contents.
Clear Glass Bottle	Excellent bottle for regular oil quality tests, affords visual inspection of sample, the water content of the samples is usually not impacted.	Breakage, sample can be susceptible to photo-degradation if not protected from the light.
Welded Seam Metal Can (Flexible-Sided)	Very durable and lightweight container, can be used for DGA and water content if filled to overflowing and the capped, sample protected from photodegradation.	Cannot view contents, must open cap to retrieve contents for DGA and some gas concentrations may be reduced as a result. Soldered seam metal cans have often been confused with welded seam cans. The flux used in soldered seam cans can severely impact the properties of the sample.
Seamless Aluminum Can	Very durable and lightweight container, excellent container for regular oil quality tests, can be used for DGA and water content if filled to overflowing and the capped, sample protected from photodegradation, bottles are usually equipped with active cap locking system.	Cannot view contents, must open cap to retrieve contents for DGA and some gas concentrations may be reduced as a result.
Particle-free Glass Bottle (amber or clear) Particle-free HDPE Bottle (amber or clear)	This is the only type of container that should be used for particle count testing as the bottle is specifically prepared to have a low background of particles. If amber then the contents are protected from photodegradation. If clear, then this affords visual inspection of sample.	Breakage, if amber then limited viewing of contents; if clear then sample can be susceptible to photodegradation if not protected from the light.
Glass Stopped Bottle	Good bottle for regular oil quality tests, affords visual inspection of sample, the water content of the samples is usually not impacted.	Breakage, sample can be susceptible to photodegradation if not protected from the light, stoppers do not always provide an adequate fit. These bottles are no longer commonly used.

ASTM International takes no position respecting the validity of any patent rights asserted in connection with any item mentioned in this standard. Users of this standard are expressly advised that determination of the validity of any such patent rights, and the risk of infringement of such rights, are entirely their own responsibility.

This standard is subject to revision at any time by the responsible technical committee and must be reviewed every five years and if not revised, either reapproved or withdrawn. Your comments are invited either for revision of this standard or for additional standards and should be addressed to ASTM International Headquarters. Your comments will receive careful consideration at a meeting of the responsible technical committee, which you may attend. If you feel that your comments have not received a fair hearing you should make your views known to the ASTM Committee on Standards, at the address shown below.

This standard is copyrighted by ASTM International, 100 Barr Harbor Drive, PO Box C700, West Conshohocken, PA 19428-2959, United States. Individual reprints (single or multiple copies) of this standard may be obtained by contacting ASTM at the above address or at 610-832-9585 (phone), 610-832-9555 (fax), or service@astm.org (e-mail); or through the ASTM website (www.astm.org). Permission rights to photocopy the standard may also be secured from the Copyright Clearance Center, 222 Rosewood Drive, Danvers, MA 01923, Tel: (978) 646-2600; <http://www.copyright.com/>