



## Standard Test Method for Saybolt Viscosity<sup>1</sup>

This standard is issued under the fixed designation D88; the number immediately following the designation indicates the year of original adoption or, in the case of revision, the year of last revision. A number in parentheses indicates the year of last reapproval. A superscript epsilon ( $\epsilon$ ) indicates an editorial change since the last revision or reapproval.

*This standard has been approved for use by agencies of the U.S. Department of Defense.*

### 1. Scope

1.1 This test method covers the empirical procedures for determining the Saybolt Universal or Saybolt Furol viscosities of petroleum products at specified temperatures between 21 and 99°C (70 and 210°F). A special procedure for waxy products is indicated.

NOTE 1—Test Methods D445 and D2170 are preferred for the determination of kinematic viscosity. They require smaller samples and less time, and provide greater accuracy. Kinematic viscosities may be converted to Saybolt viscosities by use of the tables in Practice D2161. It is recommended that viscosity indexes be calculated from kinematic rather than Saybolt viscosities.

1.2 The values stated in SI units are to be regarded as the standard. The values given in parentheses are for information only.

1.3 *This standard does not purport to address all of the safety concerns, if any, associated with its use. It is the responsibility of the user of this standard to establish appropriate safety and health practices and determine the applicability of regulatory limitations prior to use.*

### 2. Referenced Documents

#### 2.1 ASTM Standards:<sup>2</sup>

- D93 Test Methods for Flash Point by Pensky-Martens Closed Cup Tester
- D117 Guide for Sampling, Test Methods, and Specifications for Electrical Insulating Oils of Petroleum Origin
- D140 Practice for Sampling Bituminous Materials
- D244 Test Methods and Practices for Emulsified Asphalts

<sup>1</sup> This test method is under the jurisdiction of ASTM Committee D08 on Roofing and Waterproofing and is the direct responsibility of Subcommittee D08.05 on Solvent-Bearing Bituminous Compounds for Roofing and Waterproofing.

Current edition approved May 1, 2013. Published May 2013. Originally approved in 1921. In 1923, combined with former Methods D47. Last previous edition approved in 2007 as D88 – 07. DOI: 10.1520/D0088-07R13.

<sup>2</sup> For referenced ASTM standards, visit the ASTM website, www.astm.org, or contact ASTM Customer Service at service@astm.org. For *Annual Book of ASTM Standards* volume information, refer to the standard's Document Summary page on the ASTM website.

- D445 Test Method for Kinematic Viscosity of Transparent and Opaque Liquids (and Calculation of Dynamic Viscosity)
- D2161 Practice for Conversion of Kinematic Viscosity to Saybolt Universal Viscosity or to Saybolt Furol Viscosity
- D2170 Test Method for Kinematic Viscosity of Asphalts (Bitumens)
- D4057 Practice for Manual Sampling of Petroleum and Petroleum Products
- D4177 Practice for Automatic Sampling of Petroleum and Petroleum Products
- E1 Specification for ASTM Liquid-in-Glass Thermometers
- E11 Specification for Woven Wire Test Sieve Cloth and Test Sieves
- E102 Test Method for Saybolt Furol Viscosity of Bituminous Materials at High Temperatures

### 3. Terminology

#### 3.1 Definitions:

3.1.1 *Furol*—an acronym of “Fuel and road oils.”

3.1.2 *Saybolt Furol viscosity*—the corrected efflux time in seconds of 60 mL of sample flowing through a calibrated Furol orifice under specified conditions. The viscosity value is reported in Saybolt Furol seconds, abbreviated SFS, at a specified temperature.

3.1.3 *Saybolt Universal viscosity*—the corrected efflux time in seconds of 60 mL of sample flowing through a calibrated Universal orifice under specified conditions. The viscosity value is reported in Saybolt Universal seconds, abbreviated SUS, at a specified temperature.

### 4. Summary of Test Method

4.1 The efflux time in seconds of 60 mL of sample, flowing through a calibrated orifice, is measured under carefully controlled conditions. This time is corrected by an orifice factor and reported as the viscosity of the sample at that temperature.

**5. Significance and Use**

5.1 This test method is useful in characterizing certain petroleum products, as one element in establishing uniformity of shipments and sources of supply.

5.2 See Guide D117 for applicability to mineral oils used as electrical insulating oils.

5.3 The Saybolt Furol viscosity is approximately one tenth the Saybolt Universal viscosity, and is recommended for characterization of petroleum products such as fuel oils and other residual materials having Saybolt Universal viscosities greater than 1000 s.

5.4 Determination of the Saybolt Furol viscosity of bituminous materials at higher temperatures is covered by Test Method E102.

**6. Apparatus**

6.1 *Saybolt Viscometer and Bath*, as shown in Fig. 1 and described in Annex A1.

6.2 *Withdrawal Tube*, as shown in Fig. 2.

6.3 *Thermometer Support*, as shown in Fig. 3.

6.4 *Saybolt Viscosity Thermometers*, as listed in Table 1, for reading the temperature of the sample. Each thermometer shall conform to the requirements listed in Specification E1 for that ASTM Thermometer Number.

6.5 *Bath Thermometers*—Saybolt Viscosity thermometers, or any other temperature-indicating means of equivalent accuracy.

6.6 *Filter Funnel*, as shown in Fig. 4, equipped with interchangeable 150- $\mu\text{m}$  (No. 100) and 75- $\mu\text{m}$  (No. 200) wire-cloth inserts meeting the requirements of Specification E11 with respect to the wire cloth.

6.7 *Receiving Flask*, as shown in Fig. 5.

6.8 *Timer*, graduated in tenths of a second, and accurate to within 0.1 % when tested over a 60-min interval. Electric timers are acceptable if operated on a controlled frequency circuit.

**7. Sampling**

7.1 Sample the material in accordance with Practices D140, D4057, or D4177, as appropriate.

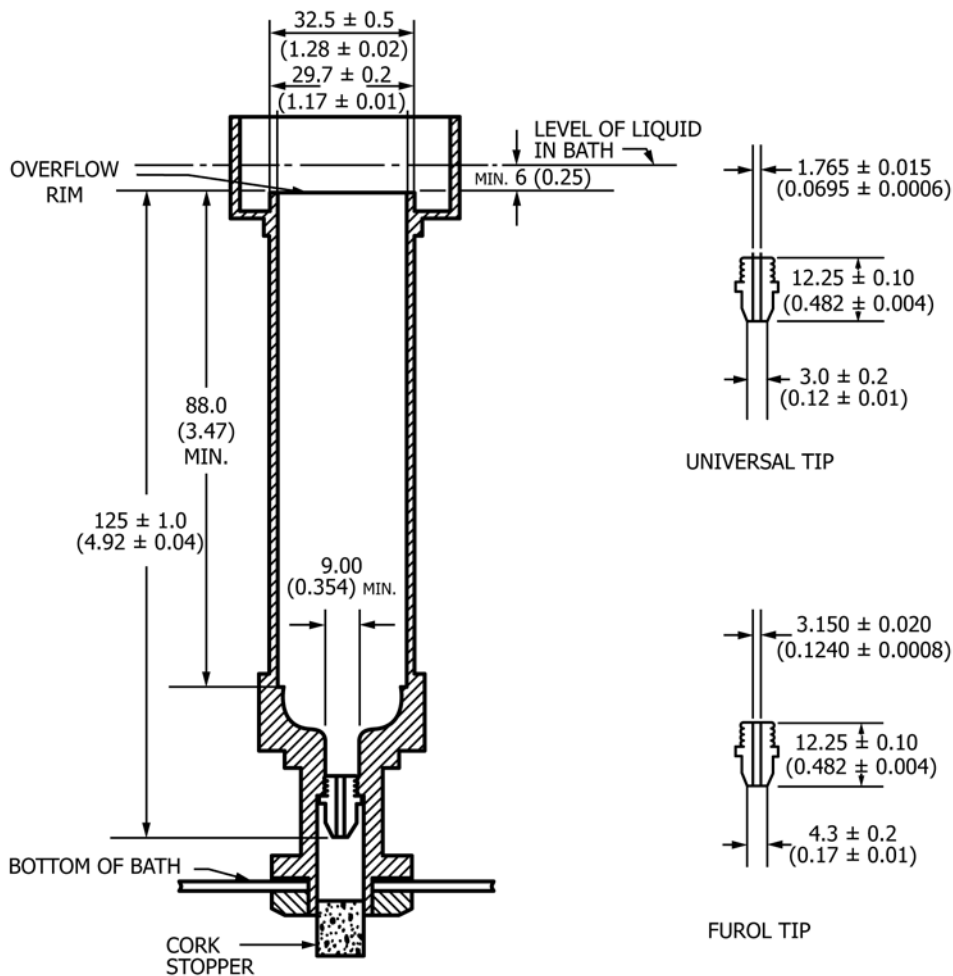

NOTE 1—All dimensions are in millimetres (inches).

**FIG. 1 Saybolt Viscometer with Universal and Furol Orifice**

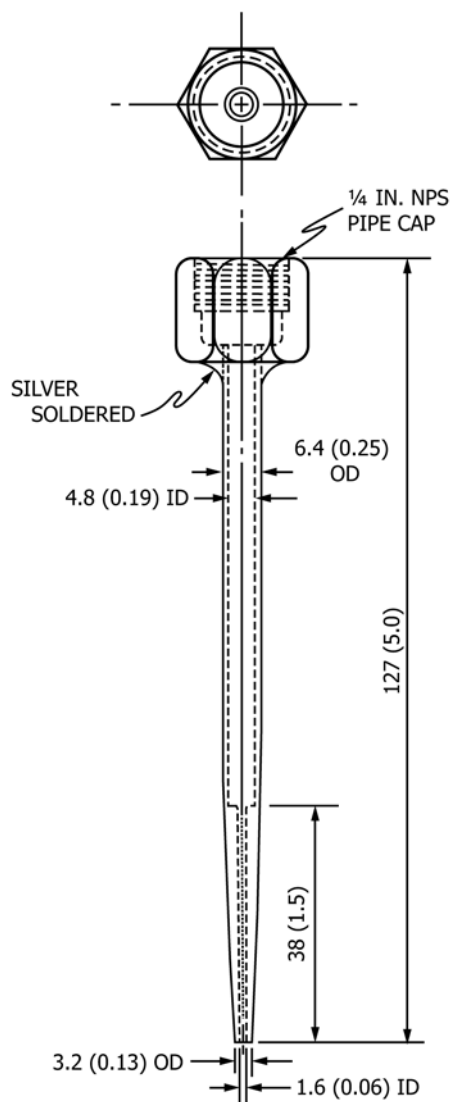

NOTE 1—All dimensions are in millimetres (inches).  
**FIG. 2 Withdrawal Tube for Use with Saybolt Viscometer**

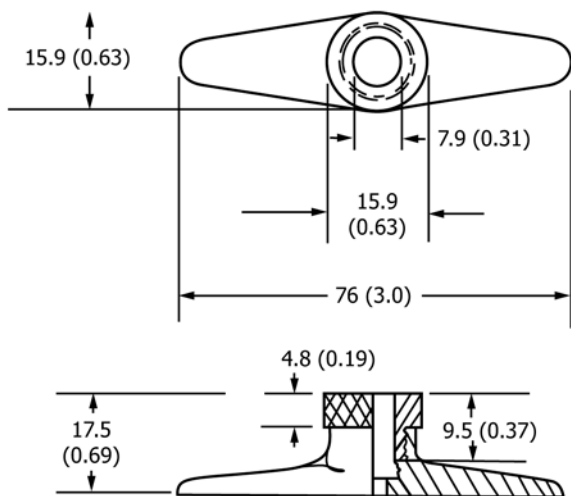

NOTE 1—All dimensions are in millimetres (inches).  
**FIG. 3 Thermometer Support**

**TABLE 1 ASTM Saybolt Viscosity Thermometers**

Standard Test Temperature °C (°F)	ASTM Thermometer No.	Thermometer	
		Range °C (°F)	Subdivisions, °C (°F)
21.1 (70)	17C (17F)	19 to 27 (66 to 80)	0.1 (0.2)
25.0 (77)	17C (17F)	19 to 27 (66 to 80)	0.1 (0.2)
37.8 (100)	18C (18F)	34 to 42 (94 to 108)	0.1 (0.2)
50.0 (122)	19C (19F)	49 to 57 (120 to 134)	0.1 (0.2)
54.4 (130)	19C (19F)	49 to 57 (120 to 134)	0.1 (0.2)
60.0 (140)	20C (20F)	57 to 65 (134 to 148)	0.1 (0.2)
82.2 (180)	21C (21F)	79 to 87 (174 to 188)	0.1 (0.2)
98.9 (210)	22C (22F)	95 to 103 (204 to 218)	0.1 (0.2)

## 8. Preparation of Apparatus

8.1 Use a Universal orifice or tip for lubricants and distillates with efflux times greater than 32 s to give the desired accuracy. Liquids with efflux times greater than 1000 s are not conveniently tested with this orifice.

8.2 Use a Furol orifice or tip for residual materials with efflux times greater than 25 s to give the desired accuracy. See also 5.3.

8.3 Clean the viscometer thoroughly with an appropriate solvent of low toxicity; then remove all solvent from the viscometer and its gallery. Clean the receiving flask in the same manner.

NOTE 2—The plunger commonly supplied with the viscometer should never be used for cleaning; its use might damage the overflow rim and walls of the viscometer.

8.4 Set up the viscometer and bath in an area where they will not be exposed to drafts or rapid changes in air temperature, and dust or vapors that might contaminate a sample.

8.5 Place the receiving flask (Fig. 5) beneath the viscometer so that the graduation mark on the flask is from 100 to 130 mm (4 to 5 in.) below the bottom of the viscometer tube, and so that the stream of oil will just strike the neck of the flask.

8.6 Fill the bath to at least 6 mm (1/4 in.) above the overflow rim of the viscometer with an appropriate bath medium selected from Table 2.

8.7 Provide adequate stirring and thermal control for the bath so that the temperature of a test sample in the viscometer will not vary more than  $\pm 0.03^\circ\text{C}$  ( $\pm 0.05^\circ\text{F}$ ) after reaching the selected test temperature.

8.8 Do not make viscosity measurements at temperatures below the dew point of the room's atmosphere.

8.9 For calibration and referee tests, keep the room temperature between 20 and 30°C (68 and 86°F), and record the actual temperature. However room temperatures up to 38°C (100°F) will not introduce errors in excess of 1 %.

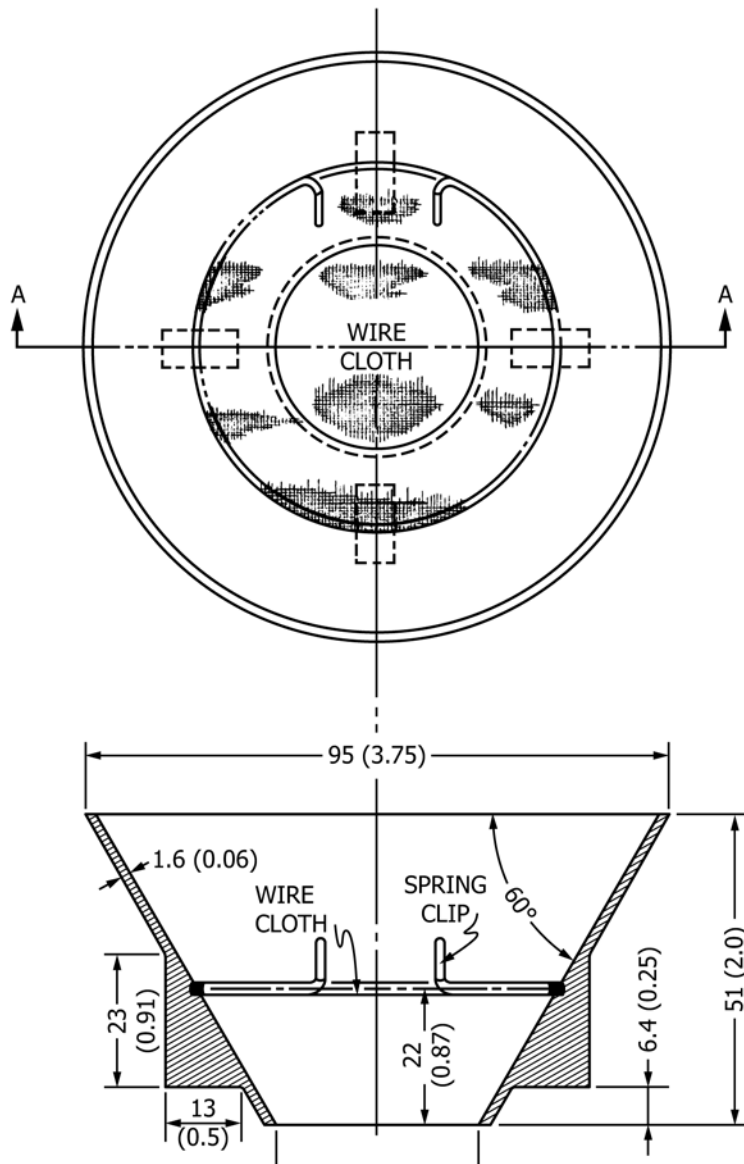

NOTE 1—All dimensions are in millimetres (inches).

FIG. 4 Filter Funnel for Use with Saybolt Viscometer

### 9. Calibration and Standardization

9.1 Calibrate the Saybolt Universal viscometer at periodic intervals by measuring the efflux time at 37.8°C (100°F) of an appropriate viscosity oil standard, following the procedure given in Section 10. See Annex A2 for viscosity oil standards available.

9.2 The efflux time of the viscosity oil standard shall equal the certified Saybolt viscosity value. If the efflux time differs from the certified value by more than 0.2 %, calculate a correction factor,  $F$ , for the viscometer as follows:

$$F = V/t \quad (1)$$

where:

$V$  = certified Saybolt viscosity of the standard, and  
 $t$  = measured efflux time at 37.8°C (100°F), s.

NOTE 3—If the calibration is based on a viscosity oil standard having an efflux time between 200 and 600 s, the correction factor applies to all

viscosity levels at all temperatures.

9.3 Calibrate the Saybolt Furol viscometer at 50.0°C (122°F) in the same manner as above, using a viscosity oil standard having a minimum efflux time of 90 s.

9.4 Viscometers or orifices requiring corrections greater than 1.0 % shall not be used in referee testing.

### 10. Procedure

10.1 Establish and control the bath temperature at the selected test temperature.

10.1.1 Standard test temperatures for measuring Saybolt Universal viscosities are 21.1, 37.8, 54.4, and 98.9°C (70, 100, 130, and 210°F).

10.1.2 Standard test temperatures for measuring Saybolt Furol viscosities are 25.0, 37.8, 50.0, and 98.9°C (77, 100, 122, and 210°F).

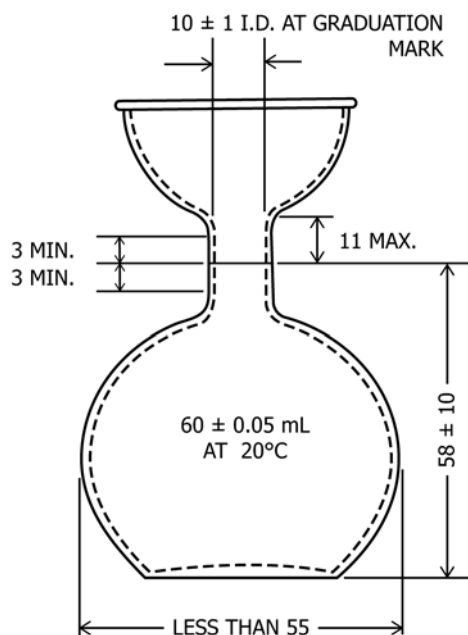

NOTE 1—All dimensions are in millimetres.

FIG. 5 Receiving Flask

10.1.3 Other standard test temperatures in use include  $60.0$  and  $82.2^\circ\text{C}$  ( $140$  and  $180^\circ\text{F}$ ).

10.2 Insert a cork stopper, having a cord attached for its easy removal, into the air chamber at the bottom of the viscometer. The cork shall fit tightly enough to prevent the escape of air, as evidenced by the absence of oil on the cork when it is withdrawn later as described.

10.3 If the selected test temperature is above room temperature, the test may be expedited by preheating the sample in its original container to not more than  $1.7^\circ\text{C}$  ( $3.0^\circ\text{F}$ ) above the test temperature. Never preheat any sample to within  $28^\circ\text{C}$  ( $50^\circ\text{F}$ ) of its flash point (see Test Methods D93), because volatility losses might alter its composition.

10.4 Stir the sample well; then strain it through the  $150\text{-}\mu\text{m}$  (No. 100) wire cloth in the filter funnel directly into the viscometer until the level is above the overflow rim.

10.5 The viscosities of steam-refined cylinder oils, black lubricating oils, residual fuel oils, and similar waxy products can be affected by their thermal histories. Use the following preheating procedure with such products to obtain uniform results at temperatures below  $93^\circ\text{C}$  ( $200^\circ\text{F}$ ):

10.5.1 Heat the sample in its original container to about  $50^\circ\text{C}$  ( $122^\circ\text{F}$ ), with stirring and shaking to dissolve and blend waxy materials. Probe the bottom of the container with a stirring rod to be certain that all waxy materials are in solution, and mix well.

10.5.2 Pour about  $100$  mL into a  $125\text{-mL}$  Erlenmeyer flask. Stopper loosely with a cork or rubber stopper.

10.5.3 Immerse the flask in a bath of boiling water for  $30$  min.

10.5.4 Mix well, remove the sample from the boiling water bath, wipe the outside of the flask dry, and strain the sample through the  $75\text{-}\mu\text{m}$  (No. 200) wire cloth in the filter funnel directly into the viscometer until the level is above the overflow rim.

10.6 Stir the sample in the viscometer with the appropriate viscosity thermometer equipped with the thermometer support (Fig. 3). Use a circular motion at  $30$  to  $50$  rpm in a horizontal plane. When the sample temperature remains constant within  $0.03^\circ\text{C}$  ( $0.05^\circ\text{F}$ ) of the test temperature during  $1$  min of continuous stirring, remove the thermometer.

NOTE 4—Never attempt to adjust the temperature by immersing hot or cold bodies in the sample. Such thermal treatment might affect the sample and the precision of the test.

10.7 Immediately place the tip of the withdrawal tube (Fig. 2) in the gallery at one point, and apply suction to remove oil until its level in the gallery is below the overflow rim. Do not touch the overflow rim with the withdrawal tube; the effective liquid head of the sample would be reduced.

10.8 Check to be sure that the receiving flask is in proper position; then snap the cork from the viscometer using the attached cord, and start the timer at the same instant.

10.9 Stop the timer the instant the bottom of the oil meniscus reaches the graduation mark on the receiving flask. Record the efflux time in seconds to the nearest  $0.1$  s.

## 11. Calculation and Report

11.1 Multiply the efflux time by the correction factor for the viscometer determined in 9.2.

11.2 Report the corrected efflux time as the Saybolt Universal or Saybolt Furol viscosity of the oil at the temperature at which the test was made.

11.2.1 Report values below  $200$  SUS or SFS to the nearest  $0.1$  s. Report values of  $200$  s or higher to the nearest whole second.

## 12. Precision and Bias

12.1 Results should not differ from the mean by more than the following (see Note 5):

- 12.1.1 Repeatability (one operator and apparatus)— $1\%$ .
- 12.1.2 Reproducibility (different operators and apparatus)— $2\%$ .

NOTE 5—For petroleum products, the precision and bias is based on data from Test Method E102. For emulsion, use precision and bias statement in Test Method D244, Section 38.

## 13. Keywords

13.1 bituminous materials; kinematic; saybolt; viscosity



**TABLE 2 Recommended Bath Media**

Standard Test Temperature, °C (°F)	Recommended Bath Medium	Max Temp Differential, <sup>A</sup> °C (°F)	Bath Temperature Control Functional Precision, °C (°F)
21.1 (70)	water	±0.05 (0.10)	±0.03 (0.05)
25.0 (77)	water	±0.05 (0.10)	±0.03 (0.05)
37.8 (100)	water, or oil of 50 to 70 SUS viscosity at 37.8°C (100°F)	±0.15 (0.25)	±0.03 (0.05)
50.0 (122)	water, or oil of 120 to 150 SUS viscosity at 37.8°C (100°F)	+ 0.20 (0.35)	±0.03 (0.05)
54.4 (130)	water, or oil of 120 to 150 SUS viscosity at 37.8°C (100°F)	+ 0.30 (0.50)	±0.03 (0.05)
60.0 (140)	water, or oil of 120 to 150 SUS viscosity at 37.8°C (100°F)	+ 0.60 (1.0)	±0.06 (0.1)
82.2 (180)	water or oil of 300 to 370 SUS viscosity at 37.8°C (100°F)	+ 0.80 (1.5)	±0.06 (0.1)
98.9 (210)	oil of 330 to 370 SUS viscosity at 37.8°C (100°F)	+ 1.10 (2.0)	±0.06 (0.1)

<sup>A</sup> Maximum permissible difference between bath and sample temperatures at the time of the test.

## ANNEXES

### (Mandatory Information)

#### A1. SAYBOLT VISCOMETER AND ACCESSORIES

A1.1 *Viscometer*—The viscometer, illustrated in Fig. 1, shall be constructed entirely of corrosion-resistant metal, conforming to dimensional requirements shown in Fig. 1. The orifice tip, Universal or Furol, may be constructed as a replaceable unit in the viscometer. Provide a nut at the lower end of the viscometer for fastening it in the bath. Mount vertically in the bath and test the alignment with a spirit level on the plane of the gallery rim. Provide a cork or other suitable means to prevent the flow of sample until the start of the test; a small chain or cord may be attached to the cork to facilitate rapid removal.

A1.2 *Bath*—The bath serves both as a support to hold the viscometer in a vertical position as well as the container for the bath medium. Equip the bath with effective insulation and with an efficient stirring device. Provide the bath with a coil for heating and cooling and with thermostatically controlled heaters capable of maintaining the bath within the functional precision given in Table 2. The heaters and coil should be located at least 30 mm from the viscometer. Provide a means for maintaining the bath medium at least 6 mm (0.25 in.) above the overflow rim. The bath media are given in Table 2.

#### A2. VISCOSITY STANDARDS

A2.1 *Saybolt Viscosity Standards*—Viscosity oil standards conforming to ASTM requirements have certified Saybolt viscosity values established by cooperative determinations of kinematic viscosity values. The kinematic values are converted to Saybolt Universal and Saybolt Furol viscosity values by means of conversion tables given in Practice D2161. The approximate Saybolt viscosities are shown in Table A2.1.

A2.2 *Standards Conforming to ASTM Saybolt Viscosity Standards*—The viscosity standards may also be used for

routine calibrations at other temperatures as shown in Table A2.1. Other reference liquids, suitable for routine calibrations, may be established by selecting stable oils covering the desired range and determining their viscosities in a viscometer calibrated with a standard conforming to ASTM requirements.

A2.3 *Routine Calibrations*—The viscosity standards may also be used for routine calibrations at other temperatures as shown in Table A2.1.

**TABLE A2.1 Saybolt Viscosity Oil Standards<sup>A</sup>**

NOTE 1—All values are nominal and will vary with lot.

Viscosity Oil Standard	At 37.8°C (100°F)		At 98.9°C (210°F)		At 50°C (122°F)	
	SUS	mm <sup>2</sup> /s	SUS	mm <sup>2</sup> /s	SUS	mm <sup>2</sup> /s
S3	36	3.0	...	...	...	...
S6	46	6.0	...	...	...	...
S20	100	20	...	...	...	...
N26	130	27	...	...	...	...
N35	170	35	...	...	...	...
N44	220	48	...	...	...	...
S60	280	60	...	...	...	...
N75	380	82	...	...	...	...
N100	500	110	...	...	...	...
N140	720	160	...	...	...	...
S200	925	200	105	20	...	...
N250	1300	280	140	29	...	...
N350	1570	340	160	32	...	...
N415	2180	470	200	41	...	...
S600	...	...	240	50	120	310
S2000	...	...	360	72	...	...

<sup>A</sup> These viscosity oil standards are available in 0.5-L containers from the Cannon Instrument Co., 2139 High Tech Rd., State College, PA 16803.

*ASTM International takes no position respecting the validity of any patent rights asserted in connection with any item mentioned in this standard. Users of this standard are expressly advised that determination of the validity of any such patent rights, and the risk of infringement of such rights, are entirely their own responsibility.*

*This standard is subject to revision at any time by the responsible technical committee and must be reviewed every five years and if not revised, either reapproved or withdrawn. Your comments are invited either for revision of this standard or for additional standards and should be addressed to ASTM International Headquarters. Your comments will receive careful consideration at a meeting of the responsible technical committee, which you may attend. If you feel that your comments have not received a fair hearing you should make your views known to the ASTM Committee on Standards, at the address shown below.*

*This standard is copyrighted by ASTM International, 100 Barr Harbor Drive, PO Box C700, West Conshohocken, PA 19428-2959, United States. Individual reprints (single or multiple copies) of this standard may be obtained by contacting ASTM at the above address or at 610-832-9585 (phone), 610-832-9555 (fax), or service@astm.org (e-mail); or through the ASTM website (www.astm.org). Permission rights to photocopy the standard may also be secured from the Copyright Clearance Center, 222 Rosewood Drive, Danvers, MA 01923, Tel: (978) 646-2600; http://www.copyright.com/*