



Designation: D8090 – 17

Standard Test Method for Particle Size Distribution and Shape Analysis of Paints and Pigments Using Dynamic Imaging Methods¹

This standard is issued under the fixed designation D8090; the number immediately following the designation indicates the year of original adoption or, in the case of revision, the year of last revision. A number in parentheses indicates the year of last reapproval. A superscript epsilon (ϵ) indicates an editorial change since the last revision or reapproval.

1. Scope

1.1 This test method covers the determination of particle size distribution and particle shape of liquid paints and pigmented liquid coatings by Dynamic Image Analysis. This method includes the reporting of particles $\geq 1 \mu\text{m}$ in size and up to $300 \mu\text{m}$ in size.

NOTE 1—Shape is used to classify particles, droplets and bubbles and is not a reporting requirement.

NOTE 2—The term paint(s) as used in this document includes liquid paint and liquid pigmented coatings.

1.1.1 Some paints may be too viscous to flow through the imaging instrument without dilution which may be used to help the paint flow as long as significant contamination is not introduced into the paint.

1.2 The values stated in SI units are to be regarded as standard. No other units of measurement are included in this standard.

1.3 *This standard does not purport to address all of the safety concerns, if any, associated with its use. It is the responsibility of the user of this standard to establish appropriate safety and health practices and determine the applicability of regulatory limitations prior to use.*

1.4 *This international standard was developed in accordance with internationally recognized principles on standardization established in the Decision on Principles for the Development of International Standards, Guides and Recommendations issued by the World Trade Organization Technical Barriers to Trade (TBT) Committee.*

2. Referenced Documents

2.1 *ASTM Standards:*²

D16 Terminology for Paint, Related Coatings, Materials, and Applications

¹ This test method is under the jurisdiction of ASTM Committee D01 on Paint and Related Coatings, Materials, and Applications and is the direct responsibility of Subcommittee D01.24 on Physical Properties of Liquid Paints and Paint Materials.

Current edition approved June 1, 2017. Published July 2017. DOI: 10.1520/D8090-17.

² For referenced ASTM standards, visit the ASTM website, www.astm.org, or contact ASTM Customer Service at service@astm.org. For *Annual Book of ASTM Standards* volume information, refer to the standard's Document Summary page on the ASTM website.

D3925 Practice for Sampling Liquid Paints and Related Pigmented Coatings

2.2 *Other Documents:*

NIST SRM 1982 Thermal Spray Powder – Particle Size Distribution³

ISO12103-1 Medium Test Dust

3. Terminology

3.1 For the definition of terms used in this standard refer to Terminology **D16**.

3.2 *Definitions:*

3.2.1 *bubble, n*—a non paint, gaseous formation within the paint, generally spherical in shape and visible as a thick walled ring with a transparent center.

3.2.2 *droplet, n*—a non paint, liquid formation within the paint, generally spherical in shape and visible as a thin walled ring with a transparent center.

3.2.3 *projected equivalent particle diameter, n*—the diameter calculated from the projected area of a particle if that area formed a circle, and in equation form is

$$\begin{aligned} \text{Projected Equivalent Particle Diameter (D)} &= \text{SQRT}(\text{Area} / (\pi / 4)) \\ &= \sqrt{(\text{Area} / 0.785)} \end{aligned}$$

3.2.4 *projected equivalent particle volume (V_D), n*—the particle volume based on the projected equivalent particle diameter, and in equation form is

$$\text{Projected Equivalent Particle Volume (} V_D) = \pi D^3 / 6 \quad (1)$$

3.2.5 *volume fraction, n*—the fraction of the total volume of particles measured which are below a given percent, and are denoted as follows:

3.2.5.1 *Dv10*—the projected equivalent diameter below which 10 % of the total volume of all particles analyzed is represented.

3.2.5.2 *Dv50*—the projected equivalent diameter below which 50 % of the total volume of all particles analyzed is represented.

³ Available from National Institute of Standards and Technology (NIST), 100 Bureau Dr., Stop 1070, Gaithersburg, MD 20899-1070, http://www.nist.gov.

3.2.5.3 *Dv90*—the projected equivalent diameter below which 90 % of the total volume of all particles analyzed is represented.

4. Summary of Test Method

4.1 Test specimen are fed through the dynamic imaging instrument which is comprised of a camera sensor and illumination source opposing each other to form a measurement zone where the fluid image is captured and then analyzed for particle size and distribution. The particle size and size distribution values are based on the projected equivalent particle diameter. Shape parameters can be used to identify air bubbles that may be present and eliminate them from the reported data. Other appropriate parameters may be used as well. Likewise for undiluted paints (for example clear paints), shape parameters can be used to eliminate air bubbles and water droplets that may be present from the reported data. Shape parameter formulations may differ from instrument to instrument.

5. Significance and Use

5.1 By following this test method, the particle size, particle size distribution and particle shape of particulates in liquid paint and pigment dispersions can be measured.

5.2 Particle size, particle size distribution and particle shape have a great effect on the color, opacity and gloss of paints. Reproducing these characteristics is critical to the quality and performance of the paint produced.

5.3 The dynamic imaging instrument is useful during manufacturing to detect oversize particles as well as the required size distribution of particles in order to provide quality and consistency from batch to batch.

6. Interferences

6.1 Contaminated environmental conditions and poor handling techniques can easily contaminate the sample. Care must be taken to ensure test results are not biased by introduced particles.

6.2 High concentrations of air bubbles, resulting from violent agitation, should be avoided. The software is designed to detect and eliminate them from the data, however high concentrations can mask other particles.

6.3 Steps should be taken to prevent the introduction of water into the paint. In undiluted paints, water droplets can be detected and counted as particles giving false positive readings. The software is designed to identify free water droplets and eliminate them from the data.

6.4 Samples may be diluted with an appropriate diluent per the instrument's manufacturer's instructions. This situation may arise due to high viscosity levels or high concentrations of particles, droplets and bubbles present in the view which may cause reporting errors. The software shall provide an alarm or error message if particle populations are too high for the instrument to accurately measure particle size, particle size distribution or particle shape.

7. Apparatus

7.1 *Dynamic Imaging Particle Analyzer*, a particle counter, shape and size measuring instrument consisting of a flow

through cell, an image capture device, means of illumination and software and readout capabilities. Fig. 1 shows a typical gravity feed system.

7.2 *Paint Shaker*—any device manufactured to agitate and mix paints in their containers.

7.3 *Instrument Stand*.

7.4 *Reservoir*—to contain and mix paint in diluted or undiluted state. Holds up to two litres (2 L) of volume.

7.5 *Agitator*—to mix contents of reservoir. Should be capable of mixing paints with viscosities up to 1 kg/m s.

7.6 *Inlet/Outlet Lines* w/full flow shut off valves.

7.7 *Drain Line*.

Alternate Configurations

7.8 *Injection Pump*—a dilution fluid supply can be plumbed in at the location of the upstream shut off valve and used as a counter flow to dilute and mix the paint in the reservoir. Controlling the flow of diluent dictates the degree of dilution of the specimen that flows through the instrument.

7.9 *Syringe Pump*—where smaller sample volumes can be effectively analyzed due to transparency of the paint a syringe can be used to sample the paint and a syringe pump can be used to propel it through the instrument.

7.10 *Luer-Lok Syringe*—a sterile syringe that can be easily and quickly connected into the feed line to the instrument.

7.11 These alternate configurations can be reviewed in Annex A1.

8. Reagents and Materials

8.1 *Reticle*, traceable to NIST or other widely recognized standards body. A 19 mm diameter reticle with 100 µm grids and 10 µm subdivisions has been found to work well for use in calibrating instruments, however various size reticles may be used as appropriate for the particular manufacturer's instrument.

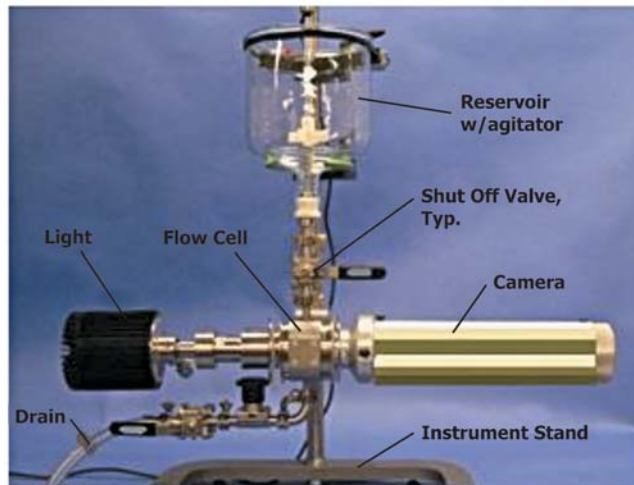

FIG. 1 Example Arrangement of a Flow Cell

8.2 *Solvent*, preferably a fast drying reagent, filtered to 0.45 micron and compatible with the particular paints being tested. For oil based paints mineral spirit has been found to work well for dilution and cleaning. For water based paints water has been found to work well for dilution and cleaning. Other common solvents may be used.

8.3 *Mono-Disperse Bead Standard*, vendor certified to be >95% spherical and a coefficient of variance <10%. Ten micron (10 µm) have been found to work well, however other sizes may also be used.

8.4 *NIST SRM 1982*, or similar particle size distribution standard traceable to NIST or similar widely known body.

9. Sample Collection and Handling

9.1 Refer to Practice **D3925** for proper sampling of paint and pigmented coatings for analysis.

9.2 Sample containers should be clearly marked identifying their contents at a minimum.

9.3 Sample volume should be per instrument manufacturer's instructions. If particle concentration is too high (see 6.4) the specimen may be diluted using an appropriate diluent filtered to 0.45 µm to remove contaminants.

10. Preparing the Instrument

10.1 Clean the instrument with a compatible solvent, filtered to 0.45 µm, by flushing the solvent through the instrument under normal operating conditions. As solvent passes through the instrument measure it for particle content. Continue to flush with fresh solvent until the particle count per mL of the solvent, as measured by the instrument, is well below normal particulate levels for the paint to be tested.

11. Calibration and Verification

11.1 Calibration

11.1.1 Instruments must be calibrated by use of a reticle traceable to NIST or other similar standard body (see 8.1). If a difference to the nominal size of particle size standard is recognized the instrument should be recalibrated. Calibration shall be performed per the instrument's manufacturer's instructions at least every 12 months.

11.2 Verification

11.2.1 Instrument calibration for size shall be verified at least every 12 months using mono-disperse beads to check (see 8.3). The standard may be diluted with water, or other appropriate diluent (see 8.2), filtered to 0.45 µm, to create a test specimen of the correct volume for the instrument. Flow the specimen through the instrument analyzing particle size for the recommended number of frames for analysis per the manufacturer's instructions. Result of mean particle size analysis must be within 3% of the particle size standard's manufacturer's certified mean value plus its standard deviation. Verification shall be performed at least every 12 months.

11.2.2 Verification of the distribution shall be done at least every 12 months. To verify wide size distributions of particles in paints (wider than 1/1.2) a poly-dispersed standard, or so called "picket fence distribution standard," must be used. It is

a mixture of different particle sizes and has several mono-dispersed particle sizes combined. NIST SRM 1982 (Sec. 8.4) or other similar standard traceable to NIST or similar widely known body is acceptable. The standard may be diluted with water, or other appropriate diluent, filtered to 0.45 µm, to create a test specimen of the correct volume and concentration for the instrument. Flow the specimen through the instrument analyzing particle size for the recommended number of frames for analysis per the manufacturer's instructions. The instrument must detect the standard manufacturer's certified percent passing particle size values within 3%, or 3 µm, plus the standard manufacturer's stated standard deviations of those size values. If not check the validity of the standard used and try again. If verification fails consult the instrument manufacturer's instruction manual. Recalibration may be required.

12. Procedure

12.1 Diluted Sample

12.1.1 Ensure the instrument is set up as indicated in the manufacturer's instructions.

12.1.2 For paints in original containers or other similar shipping containers, agitate them in those containers using a paint shaker (see 7.2). If opening the container to mechanically mix, use caution not to introduce contamination or air bubbles to the paint. Follow paint manufacturer's instructions on mixing.

12.1.3 Withdraw two test specimens from the container, one from the bottom half and the other from the top half, into two, non-reactive specimen syringes of approximately 5 mL volume. Testing has found that 1 mL of paint in 1 L of solvent is sufficient dilution for most paints, however other dilution ratios may be used. Reference the manufacturer's instructions.

12.1.3.1 Inject the first specimen into the reservoir filled with 1 L of clean solvent, agitate for 30 seconds and then flow through the instrument taking two consecutive data sets. Reference manufacturer's instruction for appropriate number of frames per data set. Calculate the mean particle size by volume, Dv_{50} , and particle size distribution for both. Rinse the reservoir and instrument with clean solvent and repeat with the second specimen. If the Dv_{50} values of the data sets for each specimen are within 10% or 5 µm, whichever is larger, then average the results of the data sets for each specimen to calculate the average Dv_{50} values.

12.1.3.2 If then the average Dv_{50} values between the top and bottom half specimen are within 10% or 5 µm, then average them together to obtain the average Dv_{50} value for the paint. Also record the Dv_{10} and Dv_{90} values for reporting at minimum. If the Dv_{50} values are not within 10% or 5 µm mix the sample again and repeat the procedure.

12.2 Undiluted Sample

12.2.1 Undiluted samples may also be analyzed if the paint is transparent enough. Follow the same procedure as in 12.1.

13. Report

13.1 The report should include the following information:

13.1.1 A reference to this test method,

13.1.2 Sample identification,

13.1.3 Particle size distribution by volume reporting at minimum Dv10, Dv50, and Dv90, and

13.1.4 Any deviations from this method.

14. Precision and Bias

14.1 An interlaboratory study has yet to be concluded. A temporary statement of repeatability is demonstrated in Annex

A1. Temporary repeatability of Dv50 values is 0.96 based on testing of one instrument in one lab.

15. Keywords

15.1 dynamic imaging; paint; particle size; pigment

ANNEX

(Mandatory Information)

A1. ALTERNATE INSTRUMENT CONFIGURATIONS

A1.1 Automated Specimen Injection and Dilution

A1.1.1 A test specimen is gathered into a syringe and metered into the mixing chamber while the diluent is injected below (Fig. A1.1). This creates a counter flow that enables the particle density to be controlled automatically by the software ensuring dispersed particle presentation to the imaging device.

Since particle distribution is measured and not concentration the dilution volume does not have to be calculated.

A1.2 Automated Specimen Injection and Dilution (Version 2) (Fig. A1.2)

A1.2.1 The principle of operation is the same as A1.1.

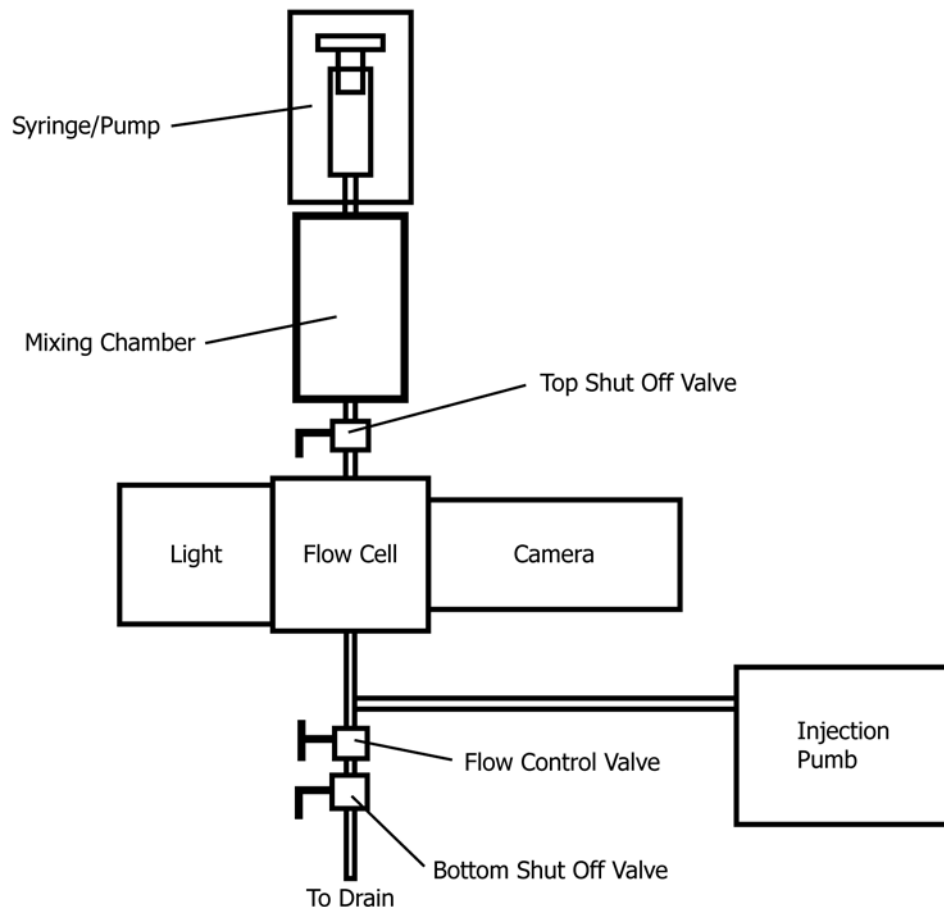

FIG. A1.1 Instrument with Injection Pump for Dilution and Syringe Pump to Meter in Specimen

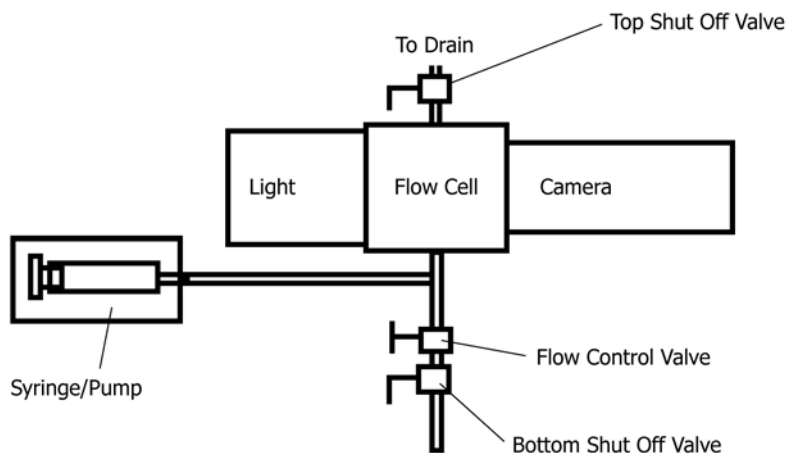

FIG. A1.2 Second Automated Configuration

APPENDIX

(Nonmandatory Information)

X1. TYPICAL PARTICLE ANALYSES DATA FOR PAINT

X1.1 Latex paint analysis is detailed in this appendix. Different commercially available paints were tested from their packaging containers. One paint was contaminated with medium AZ test dust for comparison, 0.1 mg dust added to 0.95 liters of paint.

X1.2 Analysis was done following section 12.1 for diluted paint specimen, Paint #1.

X1.2.1 Two samples were taken from the paint container, one from the top half and one from the bottom half. The paint was diluted to a 1000:1 ratio in the reservoir to create the test specimen.

X1.2.2 Two consecutive 1000 frame data sets were captured for each specimen run through the instrument and their Dv50 values were compared.

X1.2.3 The Dv50 values were required to be within 10%, or 5 µm, for the analysis to be valid. This test was repeated two more times to demonstrate repeatability. See Tables X1.1-X1.3.

X1.2.4 Each half of the paint tested consistently and they compared very closely with each other. The two specimen results were averaged to produce a single result. This test was run twice more with samples from the same paint container. Summarized results are shown in Table X1.4 for all three tests.

X1.3 Contaminated Sample

X1.3.1 An additional test was run after the paint had been contaminated by adding 0.1 mg of medium road test dust (ISO12103-1) to 0.95 l of paint. The results are shown in Table X1.5 for three tests. The Dv50 repeatability value for the contaminated sample is higher than the clean sample and is used as the temporary value for repeatability.

TABLE X1.1 Top Half Particle Analysis Specimen 1-T

	Specimen 1 – T 1st 1000 frames	Specimen 1 – T 2nd 1000 frames	Average	% Difference	r
Dv10:	3.35	3.50	3.43	4.18	0.29
Dv20:	4.74	4.99	4.87	4.91	0.48
Dv30:	6.00	6.44	6.22	6.86	0.88
Dv40:	7.50	7.92	7.71	5.35	0.84
Dv50:	9.00	9.47	9.23	4.95	0.93
Dv60:	10.93	11.50	11.22	4.94	1.12
Dv70:	13.49	13.75	13.62	1.85	0.50
Dv80:	16.30	16.27	16.28	0.23	0.07
Dv90:	19.30	18.89	19.09	2.15	0.80
Dv100:	29.36	30.87	30.11	4.88	2.98

TABLE X1.2 Bottom Half Particle Analysis Specimen 1-B

	Specimen 1 – B	Specimen 1 – B	Average	% Difference	r
	1st 1000 frames	2nd 1000 frames			
Dv10:	3.50	3.55	3.53	1.53	0.11
Dv20:	4.92	4.98	4.95	1.31	0.13
Dv30:	6.32	6.44	6.38	1.88	0.24
Dv40:	7.92	8.01	7.97	1.15	0.18
Dv50:	9.37	9.50	9.43	1.42	0.27
Dv60:	11.49	11.70	11.59	1.76	0.41
Dv70:	13.94	13.96	13.95	0.18	0.05
Dv80:	16.11	15.95	16.03	0.99	0.31
Dv90:	19.02	18.74	18.88	1.52	0.56
Dv100:	30.94	29.85	30.39	3.64	2.15

TABLE X1.3 Comparison of Top and Bottom Half Data

	Average of Specimen 1 – B	Average of Specimen 1 – B	% Difference	r	Average
Dv10:	3.43	3.53	2.83	0.20	3.48
Dv20:	4.87	4.95	1.62	0.16	4.91
Dv30:	6.22	6.38	2.51	0.32	6.30
Dv40:	7.71	7.97	3.26	0.51	7.84
Dv50:	9.23	9.43	2.12	0.40	9.33
Dv60:	11.22	11.59	3.19	0.73	11.41
Dv70:	13.62	13.95	2.37	0.65	13.79
Dv80:	16.28	16.03	1.56	0.49	16.16
Dv90:	19.09	18.88	1.11	0.42	18.99
Dv100:	30.11	30.39	0.92	0.55	30.25

TABLE X1.4 Summary of Results for Three Tests on Paint #1

	Average 1	Average 2	Average 3	Stdev	r
Dv10:	3.48	3.3	3.305	0.10	0.29
Dv20:	4.91	4.56	4.63	0.19	0.52
Dv30:	6.3	5.895	5.985	0.21	0.60
Dv40:	7.84	7.445	7.625	0.20	0.55
Dv50:	9.33	8.96	9.18	0.19	0.52
Dv60:	11.405	10.795	11.085	0.31	0.85
Dv70:	13.785	13.095	13.315	0.35	0.99
Dv80:	16.155	15.855	16.085	0.16	0.44
Dv90:	18.985	18.94	19.22	0.15	0.42
Dv100:	30.25	30.06	30.86	0.42	1.17

TABLE X1.5 Comparison of Clean versus Contaminated Particle Distribution

	Clean Paint #1					Contaminated Paint #1					
	Average 1	Average 2	Average 3	Stdev	r	Average 1	Average 2	Average 3	Average	Stdev	r
Dv10:	3.48	3.3	3.305	0.10	0.29	4.09	4.145	4.355	4.20	0.14	0.39
Dv20:	4.91	4.56	4.63	0.19	0.52	5.975	5.96	6.56	6.17	0.34	0.96
Dv30:	6.3	5.895	5.985	0.21	0.60	7.94	7.95	8.71	8.20	0.44	1.24
Dv40:	7.84	7.445	7.625	0.20	0.55	10.18	10.295	10.855	10.44	0.36	1.01
Dv50:	9.33	8.96	9.18	0.19	0.52	12.69	12.855	13.35	12.97	0.34	0.96
Dv60:	11.405	10.795	11.085	0.31	0.85	15.49	15.59	15.72	15.60	0.12	0.32
Dv70:	13.785	13.095	13.315	0.35	0.99	18.47	18.425	18.265	18.39	0.11	0.30
Dv80:	16.155	15.855	16.085	0.16	0.44	21.05	21.43	21.33	21.27	0.20	0.55
Dv90:	18.985	18.94	19.22	0.15	0.42	24.425	24.755	24.81	24.66	0.21	0.58
Dv100:	30.25	30.06	30.86	0.42	1.17	37.13	38.03	39.075	38.08	0.97	2.73

ASTM International takes no position respecting the validity of any patent rights asserted in connection with any item mentioned in this standard. Users of this standard are expressly advised that determination of the validity of any such patent rights, and the risk of infringement of such rights, are entirely their own responsibility.

This standard is subject to revision at any time by the responsible technical committee and must be reviewed every five years and if not revised, either reapproved or withdrawn. Your comments are invited either for revision of this standard or for additional standards and should be addressed to ASTM International Headquarters. Your comments will receive careful consideration at a meeting of the responsible technical committee, which you may attend. If you feel that your comments have not received a fair hearing you should make your views known to the ASTM Committee on Standards, at the address shown below.

This standard is copyrighted by ASTM International, 100 Barr Harbor Drive, PO Box C700, West Conshohocken, PA 19428-2959, United States. Individual reprints (single or multiple copies) of this standard may be obtained by contacting ASTM at the above address or at 610-832-9585 (phone), 610-832-9555 (fax), or service@astm.org (e-mail); or through the ASTM website (www.astm.org). Permission rights to photocopy the standard may also be secured from the Copyright Clearance Center, 222 Rosewood Drive, Danvers, MA 01923, Tel: (978) 646-2600; <http://www.copyright.com/>