



Standard Practice for Assessing the Tendency of Industrial Boiler Waters to Cause Embrittlement (USBM¹ Embrittlement Detector Method)²

This standard is issued under the fixed designation D807; the number immediately following the designation indicates the year of original adoption or, in the case of revision, the year of last revision. A number in parentheses indicates the year of last reapproval. A superscript epsilon (ϵ) indicates an editorial change since the last revision or reapproval.

1. Scope

1.1 This practice,³ known as the embrittlement-detector method, covers the apparatus and procedure for determining the embrittling or nonembrittling characteristics of the water in an operating boiler. The interpretation of the results shall be restricted to the limits set forth in 8.6.

NOTE 1—The embrittlement detector was designed to reproduce closely the conditions existing in an actual boiler seam. It is considered probable that the individual conditions of leakage, concentration, and stress in the boiler seam can equal those in the detector. The essential difference between the detector and the boiler is that the former is so constructed and operated that these three major factors act simultaneously, continuously, and under the most favorable circumstances to produce cracking; whereas, in the boiler the three factors are brought together only under unique circumstances. Furthermore, in the detector any cracking is produced in a small test surface that can be inspected thoroughly, while the susceptible areas in a boiler are large and can be inspected only with difficulty. In these respects the embrittlement detector provides an accelerated test of the fourth condition necessary for embrittlement, the embrittling nature of the boiler water.

NOTE 2—Cracks in a specimen after being subjected to this test indicate that the boiler water can cause embrittlement cracking, but not that the boiler in question necessarily has cracked or will crack.

1.2 The effectiveness of treatment to prevent cracking, as well as an indication of whether an unsafe condition exists, are shown by this practice. Such treatments are evaluated in terms of method specimen resistance to failure.

1.3 The practice may be applied to embrittlement resistance testing of steels other than boiler plate, provided that a

duplicate, unexposed specimen does not crack when bent 90° on a 2-in. (51-mm) radius.

1.4 The values stated in inch-pound units are to be regarded as standard. The values given in parentheses are mathematical conversions to SI units that are provided for information only and are not considered standard.

1.5 *This standard does not purport to address all of the safety concerns, if any, associated with its use. It is the responsibility of the user of this standard to establish appropriate safety and health practices and determine the applicability of regulatory limitations prior to use.*

2. Referenced Documents

2.1 ASTM Standards:⁵

A108 Specification for Steel Bar, Carbon and Alloy, Cold-Finished

A515/A515M Specification for Pressure Vessel Plates, Carbon Steel, for Intermediate- and Higher-Temperature Service

D1129 Terminology Relating to Water

D1193 Specification for Reagent Water

E3 Guide for Preparation of Metallographic Specimens

E883 Guide for Reflected-Light Photomicrography

E1351 Practice for Production and Evaluation of Field Metallographic Replicas

3. Terminology

3.1 *Definitions*—For definitions of other terms used in this practice, refer to Terminology D1129.

3.2 *Definitions of Terms Specific to This Standard:*

3.2.1 *embrittlement cracking, n*—a form of metal failure that occurs in steam boilers at riveted joints and at tube ends, the cracking being predominantly intercrystalline.

3.2.1.1 *Discussion*—This form of cracking, which has been known as “caustic embrittlement,” is believed to result from the action of certain constituents of concentrated boiler water

¹ United States Bureau of Mines.

² This test method is under the jurisdiction of ASTM Committee D19 on Water and is the direct responsibility of Subcommittee D19.03 on Sampling Water and Water-Formed Deposits, Analysis of Water for Power Generation and Process Use, On-Line Water Analysis, and Surveillance of Water.

Current edition approved Jan. 1, 2014. Published January 2014. Originally approved in 1944. Last previous edition approved in 2009 as D807 – 05 (2009). DOI: 10.1520/D0807-14.

³ This test method was developed during an investigation conducted under a cooperative agreement between the Joint Research Committee on Boiler Feedwater Studies and the United States Bureau of Mines. For information on the development of this test method reference may be made to the following: Schroeder and Berk, 1941 (1);⁴ Schroeder, Berk, and Stoddard, 1941 (2); *Transactions of the American Society of Mechanical Engineers*, 1942 (3); Whirl and Purcell, 1942 (4); and Berk and Schroeder, 1943 (5).

⁵ For referenced ASTM standards, visit the ASTM website, www.astm.org, or contact ASTM Customer Service at service@astm.org. For *Annual Book of ASTM Standards* volume information, refer to the standard's Document Summary page on the ASTM website.

upon steel under stress. For a detailed discussion as to what cracking should be considered significant for the purpose of this practice, see 8.6.

4. Summary of Practice

4.1 For embrittlement cracking of the boiler metal to be possible, the boiler water must concentrate a thousand times or more in contact with the metal under high residual or applied tensile stress. In a boiler such concentration may take place in riveted seams or in annular spaces at tube ends, and the steel at such locations may be highly stressed when the boiler is constructed or may become highly stressed when it is operated. If the chemicals in the boiler water concentrate in the seams to develop an embrittling solution, cracking may occur.

4.2 In the embrittlement detector (Fig. 1), the conditions of concentration and stress are provided by the design of the unit. Boiler water is permitted to seep slowly from the small hole through the restricted space between the contact surfaces of the test specimen and the groove in the block. As this extremely slow flow takes place toward atmospheric pressure, the heat in the metal and in the liquid causes progressive evaporation to produce an increasingly concentrated solution. When the detector is properly adjusted, concentrated boiler water is in contact with the stressed test surface of the specimen, thus providing the necessary factor to determine whether the boiler water can cause embrittlement cracking.

5. Significance and Use

5.1 Embrittlement is a form of intercrystalline cracking that is associated with the exposure of boiler steel to a combination of physical and chemical factors. For embrittlement of boiler metal to occur, the metal must be under stress, it must be at the site of a leak, and it must be exposed to the concentrated boiler water. In addition, the boiler water must be embrittling in nature. The precise chemical causes of the embrittling nature of

some waters are not well understood. Experience has shown that certain waters exhibit an embrittling characteristic while others do not.

5.2 Because embrittlement is a form of cracking, it is nearly impossible to detect in an operating boiler until a failure has occurred. In general, cracking failures tend to be sudden, and often with serious consequences. This practice offers a way to determine whether a particular water is embrittling or not. It also makes it possible to determine if specific treatment actions have rendered the water nonembrittling.

6. Apparatus

6.1 *Embrittlement Detector*—The embrittlement detector shall consist of the unit, complete with steel specimen, as shown assembled in cross section in Fig. 1 and as the installed unit in Fig. 2. The principal parts consist of a rectangular block base through which the water circulates and in which a groove has been machined to receive the test specimen, a test specimen, and a clamping plate which fits over four stud bolts in the block. When the nuts on the stud bolts are tightened, the pressure of the clamping plate molds the test specimen to the contour of the groove, thus stressing in tension the surface of the specimen. Working drawings showing the dimensions of all the machined parts are shown in Figs. 3-5. Accurate machining of the groove with respect to the small hole through which the boiler water is brought to the test surface of the specimen is especially important.

6.2 *Wrenches*—An extra-heavy box-type wrench of 1 1/16-in. (27-mm) opening is recommended for assembling and adjusting the unit. A lighter box-type wrench of 3/4-in. (19-mm) opening is recommended for the hexagonal head of the adjusting screw in the end of the specimen.

6.3 *Jig for Bending Specimen*—A jig as shown in Fig. 6, or its equivalent, is recommended for bending the specimen with a hydraulic press at the end of the test to reveal cracks that may have been formed but are too fine to be visible without additional stressing of the steel surface. Other devices may be substituted to affect the same purpose of bending the specimen

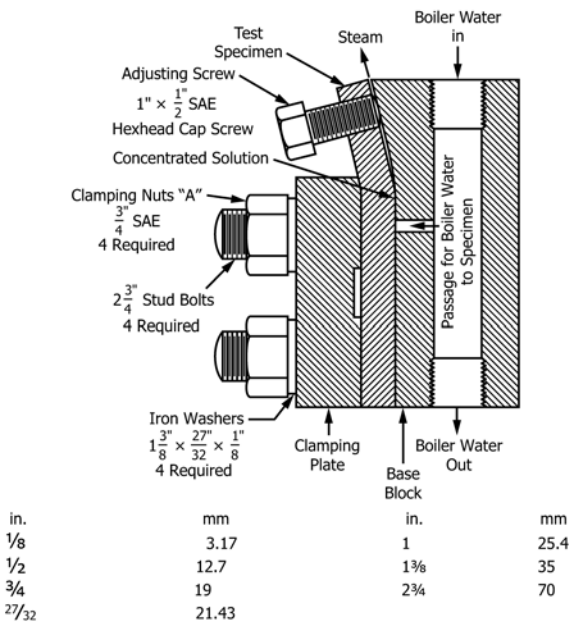

FIG. 1 Cross-Section of Embrittlement Detector

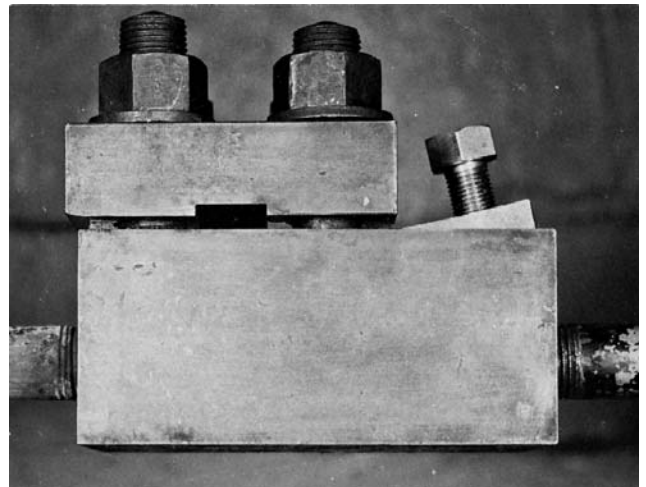
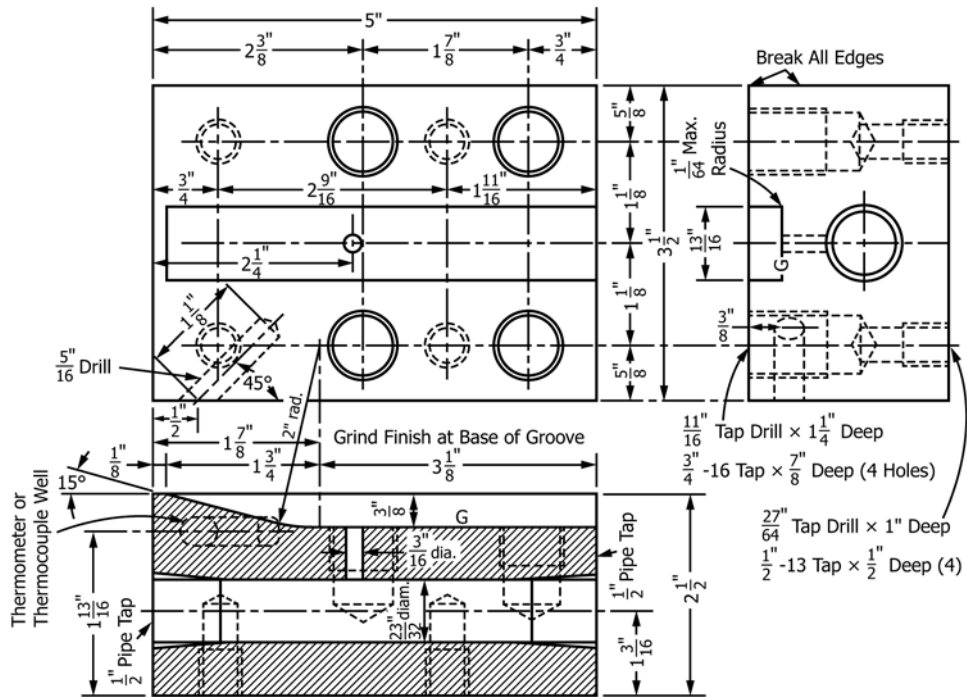
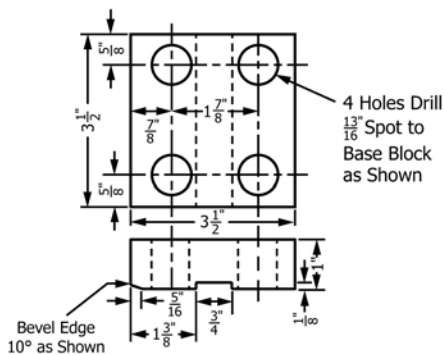

FIG. 2 Embrittlement Detector Installed



| in. | mm | in. | mm | in. | mm | in. | mm |
|-------|-------|--------|-------|---------|------|--------|------|
| 1/64 | 0.39 | 1 1/16 | 17.46 | 1 9/16 | 30 | 2 1/4 | 57 |
| 1/8 | 3.17 | 2 3/32 | 18.25 | 1 1/4 | 31.7 | 2 3/8 | 60 |
| 3/16 | 4.76 | 3/4 | 19 | 1 11/16 | 42.8 | 2 1/2 | 63.5 |
| 5/16 | 7.93 | 1 3/16 | 20.63 | 1 3/4 | 44.4 | 2 9/16 | 65 |
| 3/8 | 9.52 | 7/8 | 22.22 | 1 13/16 | 46 | 3 1/8 | 79 |
| 27/64 | 10.71 | 1 | 25.4 | 1 7/8 | 47.6 | 3 1/2 | 89 |
| 1/2 | 12.7 | 1 1/8 | 28.6 | 2 | 50.8 | 5 | 127 |
| 5/8 | 15.87 | | | | | | |

FIG. 3 Dimensional Details of Base Block of Embrittlement Detector



| in. | mm | in. | mm |
|-------|-------|-------|-------|
| 1/8 | 3.17 | 3/8 | 22.22 |
| 5/16 | 7.93 | 1 | 25.4 |
| 5/8 | 15.87 | 1 3/8 | 35 |
| 3/4 | 19 | 1 7/8 | 47.6 |
| 13/16 | 20.63 | 3 1/2 | 89 |

FIG. 4 Dimensional Details of Clamping Plate of Embrittlement Detector

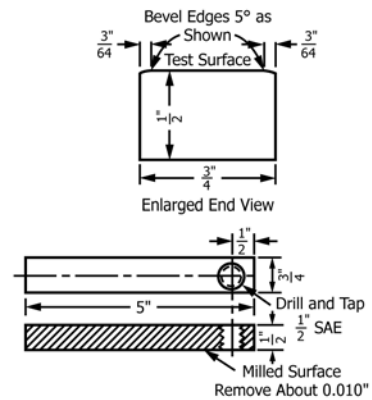

| in. | mm | in. | mm |
|-------|------|-----|-----|
| 0.010 | 0.25 | 3/4 | 19 |
| 3/64 | 1.19 | 5 | 127 |
| 1/2 | 12.7 | | |

FIG. 5 Dimensional Details of Test Specimen

uniformly in the proper place without injuring the surface to be studied (Note 3). A vise and sledge hammer shall not be used.

NOTE 3—The surface to be studied is the stressed area, which starts 1/4 in. (6 mm) above the spot corresponding to the opening in the test block and extends about 1 in. (25 mm) toward the adjusting screw.

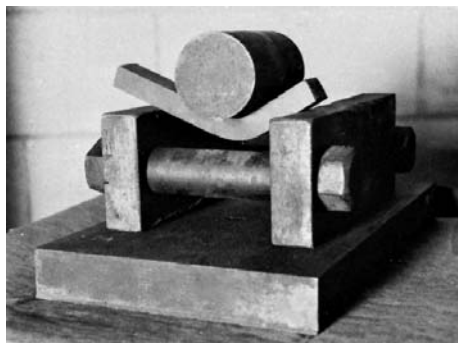

NOTE 1—Rectangular Bars of 1-in. (25-mm) Cold-Rolled Plate Held Together by 1-in. (25-mm) Bolts. Distance between Bars $\frac{3}{4}$ in. (82 mm). Pressure Transmitted by a $1\frac{1}{2}$ in. (38 mm) Round Bar.

FIG. 6 Jig for Bending Specimen after Test

7. Reagents

7.1 *Purity of Reagents*—Unless otherwise indicated, references to water shall be understood to mean reagent water conforming to Type IV of Specification **D1193**.

8. Procedure

8.1 Test Specimens:

8.1.1 Cut test specimens $\frac{1}{2}$ by $\frac{3}{4}$ by 5 in. (13 by 19 by 127 mm) from $\frac{1}{2}$ by $\frac{3}{4}$ -in. (13 by 19-mm) cold-finished bar stock (Note 4 and Note 5) conforming to Grade 1020 of Specification **A108**.

NOTE 4—Where specimens of cold-rolled steel have been cracked, similar specimens machined from boiler plate conforming to Specification **A515/A515M**, or hot-rolled steel of comparable composition may be tested to determine the severity of the embrittling condition. Hot-rolled steel has proved less susceptible to cracking than cold-rolled steel.

NOTE 5—Alloy steels are often more susceptible for cracking than the standard cold-rolled steel specified for test specimens. Where the water tested is used in alloy-steel boilers, it is desirable that the test specimen be prepared from the same material or from bars of similar composition and physical properties.

8.1.2 Finish the test surface of the specimen by either grinding with a surface grinder to a finish comparable to that produced by No. 2 metallographic polishing paper, or milling to remove surface imperfections and smoothing with No. 2 metallographic paper to remove the cutter marks. Grind and polish along the length of the specimen. If the specimen surface still shows visible flaws, such as holes, oxide, or rolling marks, after 0.01 in. (0.2 mm) has been removed, discard the specimen and prepare another one.

8.1.3 Bevel the edges of the test surface 5° , as shown in Fig. 5.

8.1.4 Center the threaded hole in the specimen for the adjusting screw and tap as specified in Fig. 5 so that the cap screw is perpendicular to the surface. The adjusting screw shall be sufficiently free so that it can be turned easily with the fingers.

NOTE 6—Specimens that have been prepared in accordance with the directions given in Section 8 may be obtained from the major water-treating companies.

8.2 Assembly of Specimen and Detector:

8.2.1 When a new specimen is to be installed in the detector (Note 7), clean the block, especially the surface of the groove, with hot water to dissolve soluble solids, and scrape lightly to remove less soluble incrustations. Polish the groove with fine emery cloth. Finally open the inlet valve for an instant to make sure that the small leakage hole is cleaned out, then wipe the groove clean. Treat the stud threads with graphite suspended in oil (Note 8).

NOTE 7—When received from the manufacturer the detector is already assembled with the specimen in position and should be steam tight. It is recommended that the specimen not be removed from the detector until after the first test is completed.

NOTE 8—A little graphite suspended in oil applied to the threads of the studs and the adjusting screw will minimize seizing. Use kerosene instead of oil if the pressure is greater than 500 psi (3.5 MPa).

8.2.2 To assemble the specimen and the detector, center the specimen with the smoothed surface facing the groove of the block so that the end with the adjusting screw hole is flush with the end of the block not grooved. Place the clamping plate over the studs, with the beveled edge inward and toward the end of the specimen containing the adjusting screw. Place the washers and nuts on the studs. Tighten alternately and evenly first the nuts on the top pairs of studs (Note 8) in the center of the detector block, thus forcing the surface of the test specimen to conform to the curvature of the groove. Then tighten the nuts on the bottom pair of studs. Finally tighten the nuts on the top pair of studs to bring the surfaces close enough together so that the small hole in the detector block groove is sealed.

NOTE 9—There shall be no leakage from the detector when the valves are opened and water at full boiler pressure flows through the block.

8.2.3 Insert the adjusting screw in the specimen and turn it down with the fingers until it just touches the block.

8.3 Installation of Detector:

8.3.1 Connect the assembled detector to the operating boiler so that boiler water will circulate through the block (Note 10). Flush clean the inlet line to the detector before the detector is attached.

NOTE 10—The detector may be installed in a bypass to a continuous blow-down line or in a recirculating line if one is available. The effluent from the detector may be returned to the boiler or discharged to waste.

8.3.2 Maintain the temperature and pressure of the water circulating through the detector block substantially the same as the temperature (Note 11) and pressure of the water in the boiler. Determine the temperature by means of a thermocouple or thermometer inserted in a small hole provided for it in the block.

NOTE 11—It will usually be found necessary to insulate the inlet line to prevent heat losses.

8.3.3 Mount the detector so that the specimen is vertical, with the adjusting screw at the top (Fig. 1 and Fig. 2). Fasten it to a rigid frame by bolts, the holes for which are provided in the back of the detector block. Considerable force is exerted on the stud bolts when a specimen is inserted and when adjustments are made, so that it is necessary for the detector to be solidly fastened. There should be a free space in front and to the sides of the detector to permit inspection and adjustments.

8.3.4 Provide the 1/2-in. (13-mm) inlet and outlet lines with valves so that the specimen may be removed and a new specimen inserted while the boiler is in operation.

8.3.5 If the boiler pressure is especially high and the plant operator objects to threaded joints, attach the detector to the inlet and outlet lines by means of a standard welding procedure such as that specified in Section IX of the ASME Boiler Construction Code, Standard Qualification for Welding Procedure and Welding Operator.⁶

8.4 *Establishing Flow to Specimen:*

8.4.1 Inspect the detector for correct assembly and installation. Back off the adjusting screw so that it does not touch the block. The clamping nuts must be drawn down tightly so that no leakage occurs when full boiler pressure is applied to the unit. If this precaution is not followed, the test may be ruined.

8.4.2 Open the valves to start circulation of the boiler water through the detector block. Where throttling is necessary, as in a wastewater line, throttle only on the outlet side.

8.4.3 When the unit is very close to boiler temperature, start the test by backing off the two upper clamping nuts equally and cautiously by tapping the end of the applied wrench lightly with a hammer.

8.4.4 Diffusion of boiler water between the contact surfaces is properly adjusted when a mist of condensed vapor, issuing from between the specimen and the block, is just barely visible on a cold piece of glass or polished metal held above the upper end of the specimen.

8.4.5 Restore the stress in the specimen by turning down the adjusting screw until it just bears on the detector block.

8.4.6 Maintain the proper rate of leakage of boiler water between the test surface and the block by adjustment not more often than once each day; and only after inspection results in a negative test on the cold, condensing surface.

NOTE 12—Do not adjust more than once each day, even when the mist of condensed vapor can be detected only for a short time after each daily adjustment.

NOTE 13—The personal factor in the operation of the embrittlement detector can result in test conditions whereby an embrittling water will not cause cracking of the test specimens. The reverse is not true. When an adjustment of the leakage rate results in even momentary excess leakage, the probability of a poor test is increased.

8.4.7 If adjustment is necessary, first turn down the adjusting screw one sixth of a turn. If this does not cause the haze to appear on the condenser surface, repeat the operations described in 8.4.3, 8.4.4, and 8.4.5.

NOTE 14—The one sixth of a turn of the adjusting screw is a maximum. Approach it cautiously and do not repeat if the haze does not appear.

NOTE 15—Exercise caution to prevent water from bubbling up under the specimen, for this indicates so high a rate of seepage that concentrated solution formed between the contact surfaces will be washed out. Caution should also be taken to prevent steam from shooting from the sides of the specimen.

8.4.8 Do not remove the test specimen or wash down the detector during the test.

8.4.9 At the completion of the test period, close the valves to and from the detector and remove the specimen for inspection.

8.4.10 Replace the specimen as described in Section 8.

8.4.11 Keep a log showing the dates when the unit was inspected, dates when adjustment was required, dates when water bubbled from the unit, and any departures from standard procedure.

NOTE 16—Boiler water analysis and log data may increase the usefulness of the records when results are compared.

8.5 *Practice Interval:*

8.5.1 Continue this practice for 30 operating days. Do not stop the practice interval over weekends or holidays because of the absence of personnel responsible for inspection or adjustment of the detector. The practice interval may be continued if the boiler is banked but up to pressure. If the boiler pressure is to be lowered, close the valves controlling the detector before the boiler is shut down and do not open until the boiler is up to pressure. It is not necessary that the 30 operating days be consecutive, but they should be as closely consecutive as possible.

8.5.2 If no cracking in the specimen is found from the first practice interval of 30 days, make a second practice interval for 60 operating days.

8.5.3 If no cracking in the test specimen is found from the second practice interval, make a third practice interval for 90 operating days.

8.5.4 Diffusion of boiler water between the contact surfaces is properly adjusted when a mist of condensed vapor, issuing from between the specimen and the block, is just barely visible on a cold piece of glass or polished metal held above the upper end of the specimen.

NOTE 17—Additional tests for periods of 90 operating days or longer may be made as a continuing check upon boiler-water conditions.

8.6 *Inspection:*

8.6.1 Inspect the specimen as removed from the detector for evidence of having been properly exposed and for color of test surface. This color will be usually dark gray or black (Note 18). Excessive solids indicate the possibility that the rate of diffusion of boiler water was too rapid and that the concentrated solution was formed in the vicinity of the adjusting screw where the specimen is not stressed rather than on the stressed area. There should be a sharply defined spot corresponding to the hole in the groove of the detector block.

NOTE 18—If the boiler water contains nitrate ions in appreciable amount, the test surface may appear red rather than dark gray or black.

8.6.2 Only the specimen inspector should remove any solid deposits from the specimen. Wash the specimen in hot water after removal of such deposits.

NOTE 19—Watch the test surface as it dries in air. Fine cracks are often revealed momentarily as the film of moisture recedes, and the depth of the crack can sometimes be determined similarly on the sides of the specimen.

8.6.3 Examine the surface of the specimen with a magnifying glass. If no cracks are visible, remove the adjusting screw and place the specimen in a jig, as shown in Fig. 6. Carefully apply pressure with a hydraulic press, or the equivalent, to

⁶For availability of this Code, contact American Society of Mechanical Engineers (ASME), ASME International Headquarters, Two Park Ave., New York, NY 10016-5990, <http://www.asme.org>.

bend the steel in the stressed area, effecting a vertical displacement of about ½ in. (13 mm). Again carefully inspect the stressed area for cracks (Note 20). Oxide coatings on specimens subjected to this test may become heavy enough to fracture when the metal is bent, and as a result the metal may become slightly fissured. Also, pits often become elongated fissures when the metal is bent. Do not confuse such fissures, check marks, and similar surface imperfections with cracks due to embrittlement.

NOTE 20—The bending may distort the steel so much that the intercrystalline path of the crack is obscured and becomes more difficult to find on metallographic examination. When this examination is to be made, the jig may still be used to reveal the existence and position of cracks, but the bar should be bent as little as possible.

8.6.4 The crack may be examined metallographically (Note 21) for evidence of intercrystalline cracking (Note 22), which constitutes positive proof of embrittlement.

NOTE 21—For recommended procedures for metallographic examination, refer to Guide E3, Guide E883, and Practice E1351.

NOTE 22—Embrittlement cracks in alloy steels often tend to be intracrystalline, following slip planes rather than grain boundaries.

9. Report

9.1 The presence of cracks in a specimen tested in accordance with this method shall be attributed to embrittlement caused by the boiler water. Failure of the specimen may be

differentiated for comparison purposes as “bad cracking,” “cracking,” or “slight cracking.”

9.2 A boiler water may be considered to have had no embrittling tendencies during the period of the practice when successive 30, 60, and 90-day practice intervals each have shown no cracking of the test specimens.

10. Precision and Bias⁷

10.1 Since the character of a boiler water may change with variation in the water supply or the chemical treatment of the water, any conclusions based upon the condition of the test specimens are strictly valid only with respect to the actual periods of exposure.

10.2 Inasmuch as a personal element is involved in the operation of the detector, there is an uncertainty factor in a test that results in no cracking. Correlation of more than 800 tests made by average plant personnel indicates that the probable chance of error is no more than 5 percent after 30, 60, and 90-day tests have been completed.

11. Keywords

11.1 boiler water; cracking; detector; embrittlement; intercrystalline

⁷ Reports of additional tests for future correlation will be welcomed and should be addressed to ASTM Headquarters, 100 Barr Harbor Drive, West Conshohocken, PA 19428.

REFERENCES

- (1) Schroeder, W. C., and Berk, A. A. “Intercrystalline Cracking of Boiler Steel and Its Prevention,” *Bulletin 443*, U.S. Bureau of Mines, 1941.
- (2) Schroeder, W. C., Berk, A. A., and Stoddard, C. K. “Embrittlement Detector Testing on Boilers,” *Power Plant Engineering*, Vol 45, August, 1941, pp. 69–76.
- (3) “Embrittlement Symposium,” *Transactions of the American Society of Mechanical Engineers*, Vol 64, 1942, pp. 393–444.
- (4) Whirl, S. F., and Purcell, T. E., “Protection Against Caustic Embrittlement by Coordinated Phosphate-pH Control,” *Proceedings, Third Annual Water Conference, Engineers’ Society of Western Pennsylvania*, 1942, pp. 45–60.
- (5) Berk, A. A., and Schroeder, W. C., “A Practical Way to Prevent Embrittlement Cracking,” *Transactions of the American Society of Mechanical Engineers*, Vol 65, 1943, pp. 701–711.

ASTM International takes no position respecting the validity of any patent rights asserted in connection with any item mentioned in this standard. Users of this standard are expressly advised that determination of the validity of any such patent rights, and the risk of infringement of such rights, are entirely their own responsibility.

This standard is subject to revision at any time by the responsible technical committee and must be reviewed every five years and if not revised, either reapproved or withdrawn. Your comments are invited either for revision of this standard or for additional standards and should be addressed to ASTM International Headquarters. Your comments will receive careful consideration at a meeting of the responsible technical committee, which you may attend. If you feel that your comments have not received a fair hearing you should make your views known to the ASTM Committee on Standards, at the address shown below.

This standard is copyrighted by ASTM International, 100 Barr Harbor Drive, PO Box C700, West Conshohocken, PA 19428-2959, United States. Individual reprints (single or multiple copies) of this standard may be obtained by contacting ASTM at the above address or at 610-832-9585 (phone), 610-832-9555 (fax), or service@astm.org (e-mail); or through the ASTM website (www.astm.org). Permission rights to photocopy the standard may also be secured from the Copyright Clearance Center, 222 Rosewood Drive, Danvers, MA 01923, Tel: (978) 646-2600; http://www.copyright.com/