



Designation: D8047 – 17

# Standard Test Method for Evaluation of Engine Oil Aeration Resistance in a Caterpillar C13 Direct-Injected Turbocharged Automotive Diesel Engine<sup>1</sup>

This standard is issued under the fixed designation D8047; the number immediately following the designation indicates the year of original adoption or, in the case of revision, the year of last revision. A number in parentheses indicates the year of last reapproval. A superscript epsilon ( $\epsilon$ ) indicates an editorial change since the last revision or reapproval.

## INTRODUCTION

Portions of this test method are written for use by laboratories that make use of ASTM Test Monitoring Center (TMC)<sup>2</sup> services (see [Annex A1](#)).

The TMC provides reference oils, and engineering and statistical services to laboratories that desire to produce test results that are statistically similar to those produced by laboratories previously calibrated by the TMC.

In general, the Test Purchaser decides if a calibrated test stand is to be used. Organizations such as the American Chemistry Council require that a laboratory utilize the TMC services as part of their test registration process. In addition, the American Petroleum Institute and the Gear Lubricant Review Committee of the Lubricant Review Institute (SAE International) require that a laboratory use the TMC services in seeking qualification of oils against their specifications.

The advantage of using the TMC services to calibrate test stands is that the test laboratory (and hence the Test Purchaser) has an assurance that the test stand was operating at the proper level of test severity. It should also be borne in mind that results obtained in a non-calibrated test stand may not be the same as those obtained in a test stand participating in the ASTM TMC services process.

## 1. Scope\*

1.1 This test method evaluates an engine oil's resistance to aeration in automotive diesel engine service. It is commonly referred to as the Caterpillar-C13 Engine-Oil Aeration Test (COAT). The test is conducted under high-engine-speed (1800 r/min), zero-load conditions using a specified Caterpillar 320 kW, direct-injection, turbocharged, after-cooled, six-cylinder diesel engine designed for heavy-duty, on-highway truck use. This test method was developed as a replacement for Test Method [D6894](#).

NOTE 1—Companion test methods used to evaluate engine oil performance for specification requirements are discussed in the latest revision of Specification [D4485](#).

<sup>1</sup> This test method is under the jurisdiction of ASTM Committee [D02](#) on Petroleum Products, Liquid Fuels, and Lubricants and is the direct responsibility of Subcommittee [D02.B0](#) on Automotive Lubricants.

Current edition approved May 1, 2017. Published May 2017. Originally approved in 2016. Last previous edition approved in 2016 as D8047 – 16. DOI: 10.1520/D8047-17.

<sup>2</sup> Until the next revision of this test method, the ASTM Test Monitoring Center will update changes in the test method by means of information letters. Information letters may be obtained from the ASTM Test Monitoring Center, 6555 Penn Avenue, Pittsburgh, PA 15206-4489, Attention Administrator. This edition incorporates revisions in all information letters through No. 16-1. <http://www.astmtmc.cmu.edu>.

1.2 The values stated in SI units are to be regarded as standard. No other units of measurement are included in this standard.

1.2.1 *Exception*—Where there is no direct SI equivalent, for example, screw threads, national pipe threads/diameters, and tubing size.

1.3 *This standard does not purport to address all of the safety concerns, if any, associated with its use. It is the responsibility of the user of this standard to establish appropriate safety and health practices and determine the applicability of regulatory limitations prior to use. See [Annex A2](#) for general safety precautions.*

1.4 This test method is arranged as follows:

	Section
Scope	1
Referenced Documents	2
Terminology	3
Summary of Test Method	4
Significance and Use	5
Apparatus	6
Engine Liquids and Cleaning Solvent	7
Preparation of Apparatus	8
Engine Stand Calibration and Non-Reference-Oil Tests	9
Procedure	10
Calculation, Test Validity and Test Results	11
Report	12
Precision and Bias	13

\*A Summary of Changes section appears at the end of this standard

Keywords	Section
ASTM Test Monitoring Center Organization	14
Safety Precautions	Annex A1
Engine and Engine Build Parts Kit	Annex A2
Oil Temperature Control System	Annex A3
Engine Modifications and Instrumentation	Annex A4
External Oil System	Annex A5
Aeration Measurement System	Annex A6
Specified Units and Formats	Annex A7
ASTM TMC: Calibration Procedures	Annex A8
ASTM TMC: Maintenance Activities	Annex A9
ASTM TMC: Related Information	Annex A10
Engine Break-in and Silicon Passivation Procedure	Annex A11
Schedule for Taking Oil Samples and Carrying out Analyses	Annex A12
Determination of Operational Validity	Annex A13
Specification for PC-10 ULSD Fuel	Annex A14
Typical System Configuration	Annex A15
	Appendix X1

1.5 *This international standard was developed in accordance with internationally recognized principles on standardization established in the Decision on Principles for the Development of International Standards, Guides and Recommendations issued by the World Trade Organization Technical Barriers to Trade (TBT) Committee.*

## 2. Referenced Documents

### 2.1 ASTM Standards:<sup>3</sup>

- [D86 Test Method for Distillation of Petroleum Products and Liquid Fuels at Atmospheric Pressure](#)
- [D93 Test Methods for Flash Point by Pensky-Martens Closed Cup Tester](#)
- [D97 Test Method for Pour Point of Petroleum Products](#)
- [D130 Test Method for Corrosiveness to Copper from Petroleum Products by Copper Strip Test](#)
- [D235 Specification for Mineral Spirits \(Petroleum Spirits\) \(Hydrocarbon Dry Cleaning Solvent\)](#)
- [D445 Test Method for Kinematic Viscosity of Transparent and Opaque Liquids \(and Calculation of Dynamic Viscosity\)](#)
- [D482 Test Method for Ash from Petroleum Products](#)
- [D524 Test Method for Ramsbottom Carbon Residue of Petroleum Products](#)
- [D613 Test Method for Cetane Number of Diesel Fuel Oil](#)
- [D664 Test Method for Acid Number of Petroleum Products by Potentiometric Titration](#)
- [D975 Specification for Diesel Fuel Oils](#)
- [D976 Test Method for Calculated Cetane Index of Distillate Fuels](#)
- [D1319 Test Method for Hydrocarbon Types in Liquid Petroleum Products by Fluorescent Indicator Adsorption](#)
- [D2274 Test Method for Oxidation Stability of Distillate Fuel Oil \(Accelerated Method\)](#)
- [D2709 Test Method for Water and Sediment in Middle Distillate Fuels by Centrifuge](#)
- [D3524 Test Method for Diesel Fuel Diluent in Used Diesel Engine Oils by Gas Chromatography](#)
- [D4052 Test Method for Density, Relative Density, and API](#)

- [Gravity of Liquids by Digital Density Meter](#)
- [D4175 Terminology Relating to Petroleum Products, Liquid Fuels, and Lubricants](#)
- [D4485 Specification for Performance of Active API Service Category Engine Oils](#)
- [D5185 Test Method for Multielement Determination of Used and Unused Lubricating Oils and Base Oils by Inductively Coupled Plasma Atomic Emission Spectrometry \(ICP-AES\)](#)
- [D5186 Test Method for Determination of the Aromatic Content and Polynuclear Aromatic Content of Diesel Fuels and Aviation Turbine Fuels By Supercritical Fluid Chromatography](#)
- [D5453 Test Method for Determination of Total Sulfur in Light Hydrocarbons, Spark Ignition Engine Fuel, Diesel Engine Fuel, and Engine Oil by Ultraviolet Fluorescence](#)
- [D6078 Test Method for Evaluating Lubricity of Diesel Fuels by the Scuffing Load Ball-on-Cylinder Lubricity Evaluator \(SLBOCLE\)](#)
- [D6894 Test Method for Evaluation of Aeration Resistance of Engine Oils in Direct-Injected Turbocharged Automotive Diesel Engine](#)
- [D7549 Test Method for Evaluation of Heavy-Duty Engine Oils under High Output Conditions—Caterpillar C13 Test Procedure](#)
- [E29 Practice for Using Significant Digits in Test Data to Determine Conformance with Specifications](#)

## 3. Terminology

### 3.1 Definitions:

3.1.1 *automotive, adj*—descriptive of equipment associated with self-propelled machinery, usually vehicles driven by internal combustion engines. **D4175**

3.1.2 *blowby, n—in internal combustion engines*, that portion of the combustion products and unburned air/fuel mixture that leaks past piston rings into the engine crankcase during operation. **D4175**

3.1.3 *break-in, v—in internal combustion engines*, the running of a new engine under prescribed conditions to help stabilize engine response and help remove initial friction characteristics associated with new engine parts. **D4175**

3.1.4 *calibrate, v—to determine the indication or output of a measuring device or a given engine with respect to a standard.* **D4175**

3.1.5 *calibrated test stand, n—a test stand on which the testing of reference material(s), conducted as specified in the standard, provided acceptable test results.*

3.1.5.1 *Discussion*—In several automotive lubricant standard test methods, the ASTM Test Monitoring Center provides testing guidance and determines acceptability. **D4175**

3.1.6 *calibration oil, n—an oil that is used to determine the indication or output of a measuring device or a given engine with respect to a standard.* **D4175**

3.1.7 *calibration test, n—an engine test conducted on a reference oil under carefully prescribed conditions, the results of which are used to determine the suitability of the engine stand/laboratory for such tests on non-reference oils.*

<sup>3</sup> For referenced ASTM standards, visit the ASTM website, [www.astm.org](http://www.astm.org), or contact ASTM Customer Service at [service@astm.org](mailto:service@astm.org). For *Annual Book of ASTM Standards* volume information, refer to the standard's Document Summary page on the ASTM website.

3.1.7.1 *Discussion*—A calibration test also includes tests conducted on parts to ensure their suitability for use in reference and non-reference tests. **D4175**

3.1.8 *candidate oil, n*—an oil that is intended to have the performance characteristics necessary to satisfy a specification and is to be tested against that specification.

3.1.8.1 *Discussion*—These oils are mainly submitted for testing as candidates to satisfy a specified performance; hence the designation of the term. **D4175**

3.1.9 *engine oil, n*—a liquid that reduces friction or wear, or both, between the moving parts within an engine; removes heat particularly from the underside of pistons; and serves as combustion gas sealant for the piston rings.

3.1.9.1 *Discussion*—It may contain additives to enhance certain properties. Inhibition of engine rusting, deposit formation, valve train wear, oil oxidation, and foaming are examples. **D4175**

3.1.10 *foam, n—in liquids*, a collection of bubbles formed in the liquid or on (at) its surface in which the air (or gas) is the major component on a volumetric basis. **D4175**

3.1.11 *heavy-duty engine, n—in internal combustion engine types*, one that is designed to allow operation continuous at or close to its peak output.

3.1.11.1 *Discussion*—This type of engine is typically installed in large trucks and buses as well as farm, industrial, and construction equipment. **D4175**

3.1.12 *lubricant, n*—any material interposed between two surfaces that reduces the friction or wear, or both, between them. **D4175**

3.1.13 *lubricant test monitoring system (LTMS), n*—an analytical system in which ASTM calibration test data are used to manage lubricant test precision and severity (bias). **D4175**

3.1.14 *mass fraction of B, w<sub>B</sub>, n*—mass of a component B in a mixture divided by the total mass of all the constituents of the mixture.

3.1.14.1 *Discussion*—Values are expressed as pure numbers or the ratio of two units of mass (for example, mass fraction of lead is  $w_B = 1.3 \times 10^{-6} = 1.3 \text{ mg/kg}$ ).

3.1.15 *non-reference oil, n*—any oil other than a reference oil; such as a research formulation, commercial oil, or candidate oil. **D4175**

3.1.16 *quality index (QI), n*—a mathematical formula that uses data from controlled properties to calculate a value indicative of control performance. **D4175**

3.1.17 *quantity, n—in the SI*, a measurable property of a body or substance where the property has a magnitude expressed as the product of a number and a unit; there are seven, well-defined base quantities (length, time, mass, temperature, amount of substance, electric current, and luminous intensity) from which all other quantities are derived (for example, volume, whose SI unit is the cubic metre).

3.1.17.1 *Discussion*—Symbols for quantities must be carefully defined; are written in italic font, can be upper or lower case, and can be qualified by adding further information in subscripts, or superscripts, or in parentheses (for example,  $T_{\text{fuel}}$

= 40 °C, where  $T$  is used as the symbol for the quantity temperature and  $T_{\text{fuel}}$  is the symbol for the specific quantity fuel temperature).

3.1.18 *reference oil, n*—an oil of known performance characteristics, used as a basis for comparison.

3.1.18.1 *Discussion*—Reference oils are used to calibrate testing facilities, to compare the performance of other oils, or to evaluate other materials (such as seals) that interact with oils. **D4175**

3.1.19 *test oil, n*—any oil subjected to evaluation in an established procedure.

3.1.19.1 *Discussion*—It can be any oil selected by the laboratory conducting the test. It could be an experimental product or a commercially available oil. Often it is an oil that is a candidate for approval against engine oil specifications (such as manufacturers' or military specifications, and so forth). **D4175**

3.1.20 *volume fraction of B, φ<sub>B</sub>, n*—volume of component B divided by the total volume of the all the constituents of the mixture prior to mixing.

3.1.20.1 *Discussion*—Values are expressed as pure numbers or the ratio of two units of volume (for example,  $\phi_B = 0.012 = 1.2 \% = 1.2 \text{ cL/L}$ ).

### 3.2 *Definitions of Terms Specific to This Standard:*

3.2.1 *aeration, n—in lubricants*, the action of impregnating with air that forms foam bubbles in or on the surface of a lubricant or is entrained as a dispersion in that lubricant.

3.2.2 *flush, n*—the action of cleaning out the engine oil system using new test oil to remove any residues as well as to minimize possible carryover effect from the previous test oil.

### 3.3 *Abbreviations and Acronyms:*

3.3.1 *ACERT*—Advanced Combustion Emission Reduction Technology

3.3.2 *ACM*—Alkyl Acrylate Copolymer

3.3.3 *BL*—Baseline (refers to density of fresh, un-aerated oil at 90 °C)

3.3.4 *BOT*—Beginning of Test

3.3.5 *CARB*—California Air Resources Board

3.3.6 *Car<sup>4</sup>*—abbreviation for Caterpillar

3.3.7 *COAT*—Caterpillar-C13 Oil-Aeration Test

3.3.8 *ELC<sup>5</sup>*—Extended-Life Coolant

3.3.9 *EOAT*—Engine-Oil Aeration Test

3.3.10 *ET*—Engine Technician

3.3.11 *EOT*—End of Test

3.3.12 *FDM*—Flow and Density Meter

3.3.13 *ICP-AES*—Inductively Coupled Plasma Atomic Emission Spectrometry

3.3.14 *ID*—Internal Diameter

3.3.15 *LTMS*—Lubricant Test Monitoring System

3.3.16 *NPT*—National Pipe Thread

3.3.17 *OA*—Oil Aeration

3.3.18 *P/N*—Part Number (applies only to parts sourced from Caterpillar)

<sup>4</sup> Registered trademark of Caterpillar Inc., 100 North East Adams St., Peoria, IL 61629.

<sup>5</sup> Trademark of Caterpillar Inc., 100 North East Adams St., Peoria, IL 61629.

3.3.19 *QI*—Quality Index

3.3.20 *SLBOCLE*—Scuffing Load Ball-on-Cylinder Lubricity Evaluator

3.3.21 *TMC*—Test Monitoring Center of ASTM

3.3.22 *ULSD fuel*—Ultra-Low-Sulfur Diesel fuel

3.4 *Quantity Symbols:*

3.4.1 *OA*—Oil Aeration, %, (see 11.1.1.3)

3.4.2  $P_{\text{SAMPLE}}$ —Pressure of the aerated oil sampled during the 50 h test determined as the average of the FDM inlet- and outlet-pressures (see 10.5.6.3)

3.4.3 *T*—Temperature (see 10.4.2.3)

3.4.4  $T_{\text{SAMPLE}}$ —Temperature of the aerated oil sampled during the 50 h test determined as the average of the FDM inlet- and outlet-temperatures (see 10.5.6.4)

3.4.5  $\rho$ —density (see 10.4.2.3)

3.4.6  $\rho_{\text{AIR}}$ —air density calculated at the temperature and pressure of the aerated oil sample during the 50 h test (see 11.1.1.2)

3.4.7  $\rho_{\text{BL}, 90}$ —baseline density of the unaerated fresh oil at 90 °C determined as the intercept of the D4052 density versus temperature regression (see 10.4.2.3)

3.4.8  $\rho_{\text{SAMPLE}}$ —the measured FDM density of the aerated oil sampled during the 50 h test at the temperature  $T_{\text{SAMPLE}}$  (see 10.5.6.4)

3.4.9  $\rho_{\text{SAMPLE}, 90}$ —the calculated FDM density of the aerated oil sampled during the 50 h test at 90 °C (see 11.1.1.1)

3.4.10  $\frac{d}{dT} \rho_{\text{BL}}$ —temperature dependence of the baseline density of fresh, un-aerated oil determined as the slope of the density vs. temperature regression of fresh, un-aerated oil (see 10.4.2.3)

## 4. Summary of Test Method

4.1 This test method uses a production Caterpillar C13 diesel engine. It is installed on a stand equipped with appropriate instrumentation to record and control various operating quantities. This test is run on an engine that is built with new components and then used for multiple oil evaluations until operational conditions or aeration performance are impacted by the engine condition.

4.2 The test operation involves two test oil flushes of 40 min duration for each test, a test warmup for 40 min and then a test length of 50 h at high-engine-speed (1800 r/min), zero-load conditions.

4.3 The percent aeration of the engine oil is determined using a flow and density meter to continuously monitor the density of a small portion of diverted gallery oil flow that has controlled pressure, temperature, and flow rate. The density of this oil is used to calculate the percentage of total sample volume that is entrained air.

## 5. Significance and Use

5.1 *Background*—Prior to this test method, the ability of an engine lubricant to resist aeration was measured by the engine-oil aeration test (EOAT) described in Test Method D6894. The continued availability of engine parts coupled with field service aeration problems led to concerns about the relevance of this test method to newer oil and engine technolo-

gies. These concerns prompted the development of this new engine-oil aeration test method, based on the Caterpillar C13 engine and termed COAT. This test method aims to provide a more reliable measurement of the ability of a lubricant to resist aeration during engine operation in field service. The engine used is of current technology and the aeration measurement is operator independent.

5.2 *Test Method*—This test method evaluates aeration performance under high-engine-speed, zero-load operation in a turbocharged, heavy-duty, four-stroke diesel engine.

5.3 *Use:*

5.3.1 The tendency of engine oils to aerate in direct-injection, turbocharged diesel engines is influenced by a variety of factors, including engine oil formulation, oil temperature, sump design and capacity, residence time of the oil in the sump, and the design of the pressurized oil systems. In some engine-oil-activated systems, the residence time of the oil in the sump is insufficient to allow dissipation of aeration from the oil. As a consequence, aerated oil can be circulated to hydraulically activated components, adversely affecting the engine timing characteristics and engine operation.

5.3.2 The results from this test method may be compared against specification requirements such as Specification D4485 to ascertain acceptance.

5.3.3 The design of the test engine used in this test method is representative of many, but not all, diesel engines. This factor, along with the unique operating conditions, needs to be considered when comparing the test results against specification requirements.

## 6. Apparatus

6.1 *Test Stand*—The test stand consists of the test engine and the aeration measurement system.

6.1.1 *Test Engine*—The test engine is a production 2004 Caterpillar 320 kW C13 engine,<sup>6,7</sup> designed for heavy-duty, on-highway truck use. It is an electronically controlled, turbocharged, after-cooled, direct-injected, six-cylinder diesel engine with an in-block camshaft and a four-valve per cylinder arrangement. The engine uses Caterpillar’s ACERT technology featuring multiple injections per cycle and inlet-valve actuation control. It features a 2004 US EPA emissions configuration with electronic control for metering of the fuel and timing the fuel injection and inlet-valve actuation. See Annex A3 for the source of the test engine and critical and non-critical parts.

6.1.2 *Aeration-Measurement System*—The aeration measurement system uses the density measurement to calculate the percent entrained air volume within the engine oil at a given pressure and temperature. The system utilizes a Micro Motion Elite, Model CMF 025,<sup>8,7</sup> coriolis-based, flow and density meter (FDM) capable of measuring density to less than

<sup>6</sup> The sole source of supply of the apparatus known to the committee at this time is Caterpillar Inc., 100 North East Adams St., Peoria, IL 61629.

<sup>7</sup> If you are aware of alternative suppliers, please provide this information to ASTM International Headquarters. Your comments will receive careful consideration at a meeting of the responsible technical committee<sup>1</sup> which you may attend.

<sup>8</sup> The sole source of supply of the apparatus known to the Committee at this time is Emerson Process Management Micro Motion Americas, 7070 Winchester Circle, Boulder, CO 80301. www.emersonprocess.com.



1 kg/m<sup>3</sup>. The calculation of the percent aeration is based on the difference in density between an un-aerated oil sample (measured by Test Method [D4052](#)) and the density of the aerated oil during the test measured by the FDM. The aeration measurement system comprises a heated line, a pressure-control valve, the FDM, a variable-speed pump, and pressure transducers and thermocouples. Assemble the system with the indicated line lengths, fittings and components as shown in [Annex A7](#). The aeration measurement system is enclosed in a cabinet capable of maintaining the internal temperature at 50 °C regardless of ambient temperatures. This temperature is typically maintained by an internal heater and insulation within the cabinet. Include the FDM, FDM-inlet and -outlet thermocouples and pressure transducers in the enclosure.

### 6.2 Test-Engine Configuration:

6.2.1 *Oil-Heat-Exchanger and Oil-Heat System*—Replace the standard Caterpillar oil-heat-exchanger core with a stainless steel core, Caterpillar P/N 1Y-4026.<sup>6,7</sup> Additionally, install a remotely mounted heat exchanger. Control the oil temperature with a dedicated cooling loop and control system which is separate from the engine coolant (see [Annex A4](#)). Ensure that the oil-cooler bypass valve is blocked closed.

NOTE 2—In subsequent text, P/N denotes the part number for parts sourced from Caterpillar. Footnotes 6 and 7 apply.

6.2.2 *Oil-Pan Modification*—Modify the oil pan as shown in [Figs. A5.1-A5.4](#). Install the oil-pan jacket as shown in [Fig. A5.5](#).

6.2.3 *Engine-Control Module (ECM)*—The ECM defines the desired engine fuel timing and quantity. It also limits maximum engine speed and power. Caterpillar electronic governors are designed to maintain a speed indicated by the throttle position signal. Speed variation drives fuel demand (rack). Rack and engine speed are input to the injection duration and timing maps to determine duration and timing commands for the fuel injectors. Obtain special oil-test, engine-control software (module P/N 250-6775-03) for correct maps. Contact the Caterpillar oil-test representative through TMC for installation of this software. Use the Caterpillar engine technician (ET) service software package, version 2004B or later, to monitor engine parameters, flash software, and to change power and injector trim values. Use the full dealer version purchased from a Caterpillar dealer with a yearly subscription.

6.2.4 *Crankshaft-Position Sensor*—Sense the crankshaft position using a primary sensor at the crankshaft gear and a secondary sensor at the camshaft gear. The secondary sensor provides position information during cranking and in the event of a primary sensor position failure. *Calibrate the engine control software before starting the timed test operation.*

6.2.5 *Air Compressor*—Do not use the engine-mounted air compressor for this test method. Remove the air compressor and in its place install block-off plates, as shown in [Fig. A5.6](#). P/N 227-2574 (cover group) and P/N 223-3873 (plug group) have been found satisfactory for this purpose.

6.2.6 *Turbocharger*—Modify the turbocharger wastegate for manual control by replacing the supplied pressure control with a manual linkage. See [Figs. A5.21-A5.23](#).

### 6.3 Test-Stand Configuration:

6.3.1 *For Full-Load Break-in*—Configure the stand with a drive-line and dynamometer capable of meeting the conditions described in the break-in and on-test subsections in Section 10, Procedure, of Test Method [D7549](#).

6.3.2 *Engine Mounting*—Install the engine so that it is upright and the crankshaft is horizontal.

6.3.2.1 Configure the engine-mounting hardware to minimize block distortion when the engine is fastened to the mounts. Excessive block distortion may influence test results.

6.3.3 *Intake-Air System*—With the exception of the air filter and intake-air tube, the intake-air system is not specified. See [Fig. X1.1](#) for a typical configuration. Use a suitable air filter. Install the intake-air tube ([Fig. A5.7](#)) at the intake of the turbocharger compressor. The intake-air tube is a minimum 305 mm of straight, nominal 102 mm diameter tubing. The system configuration upstream of the air tube is not specified.

NOTE 3—Difficulty in achieving or maintaining intake-manifold pressure or intake-manifold temperature, or both, may be indicative of insufficient or excessive restriction.

6.3.4 *Charge-Air Cooler*—In addition to the Caterpillar-supplied, charge-air cooler which is engine mounted, use another cooler to simulate the air-to-air charge air cooler used in most field applications. A Modine<sup>9,7</sup> cooler (part number 1A012865) has been found suitable for this use.<sup>10</sup> Alternatively, other charge air coolers may be used that provide sufficient cooling capacity to control inlet-manifold temperatures in the range specified elsewhere in this test method. Equip all coolers with a drain system to remove condensate continuously from the boost air cooler outlet side. Remove the coolant-diverter-valve diaphragm for the Caterpillar-supplied, charge-air cooler.

6.3.5 *Exhaust System*—Install the exhaust tube, see [Fig. A5.8](#), at the discharge flange of the turbocharger-turbine housing. Downstream exhaust piping is required but is left to the discretion of the laboratory to fabricate. Include a method to control exhaust back pressure.

6.3.6 *Fuel System*—The fuel-supply and filtration system is not specified. See [Fig. X1.2](#) for a typical configuration. Determine the fuel-consumption rate by measuring the rate of fresh fuel flowing into the day tank. Provide a method to control fuel temperature. Return the excess fuel from the engine into the day tank.

6.3.7 *Coolant System*—The system configuration is not specified. See [Fig. X1.3](#) showing a typical configuration consisting of a non-ferrous core heat exchanger, a reservoir (expansion tank), and a temperature-control valve. Pressurize the system by regulating air pressure at the top of the expansion tank. Ensure the system has a sight glass to detect air entrapment.

<sup>9</sup> The sole source of supply of this cooler known to the committee at this time is Modine Manufacturing Company. [www.modine.com](http://www.modine.com).

<sup>10</sup> Obtain the Modine cooler from a Mack Truck dealer. Order the aftercooler using part number 5424 03 928 031. This is a non-stocked part in the Mack Parts Distribution System and appears as an invalid part number. Instruct the dealer to expedite the aftercooler on a Ship Direct purchase order. The aftercooler will be shipped directly from Modine, bypassing the normal Mack Parts Distribution System.

6.3.7.1 System volume is not specified. Avoid a very large volume as it may increase the time required for the engine coolant to reach operating temperatures.

6.3.8 *Pressurized Oil-Fill System*—The oil-fill system is not specified. A typical system includes an electric pump, a 50 L reservoir, and a transfer hose. Fig. A5.24 shows the location of the pressurized oil-fill system.

6.3.9 *External Oil System for Full-Load Break-in:*

6.3.9.1 Configure the oil system as shown in Fig. A6.1 for full-load break-in of new or rebuilt engines only. Do not use this system during the oil aeration test cycle. The capacity of the oil reservoir is 10 L to 13 L. Ensure that the oil return is drawn from the bottom of the oil reservoir—see Fig. A5.10. Use Viking Pump Model No. SG053514.<sup>11,7</sup> Locate the external oil pumps at a depth that is below the pump supply fitting on the oil pan. The nominal speed for the oil-pump motor is 1725 r/min. Figs. A5.1-A5.5 show the pump supply and return port locations. This system is removed for testing after the break-in and during the aeration tests. The locations for the pump supply and return port of the oil pan are capped when this system is not in use.

6.3.9.2 *Oil-Sample Valve Location*—Locate the oil-sample valve on the oil-sump drain port.

6.3.9.3 *Unacceptable Oil-System Materials*—Do not use brass or copper fittings because they can adversely influence the analyses for oil-wear metals in the external oil system.

6.3.10 *Crankcase Aspiration*—Vent the blowby gas at the blowby filter housing located at the left-front side of the cylinder head cover (Fig. A5.11). Use crankcase breather P/N 9Y-4357. Use breather spacer P/N 221-3934 or equivalent plate 20 mm thick with a fully-open center. Use gasket P/N 9Y-1758 on each side of the spacer.

6.3.11 *Blowby Rate*—See the general configuration of this system in Fig. A5.11. The minimum internal volume of the blowby canister is 26.5 L. The inside diameter of the pipe connecting the breather outlet to the blowby canister is 32 mm. Incline the pipe downward to the canister. The hose connecting the blowby canister to the device for measuring the flow rate is not specified but it shall match closely to the inlet of the device. The device for measurement of flow rate is not specified, but shall be capable of measuring approximately 70 L/min. The J-TEC Associates, Inc. Model No. YF563A or YF563B<sup>12,7</sup> have been found to give satisfactory results under the conditions specified in this test method.

6.4 *System-Time Responses*—The maximum allowable system-time responses are shown in Table 1. Determine system-time responses in accordance with the Data Acquisition and Control Automation II (DACA II) Task Force Report.<sup>13</sup>

TABLE 1 Maximum Allowable System-Time Responses

Quantity	Time Response
Speed	2.0 s
Temperature	3.0 s
Pressure	3.0 s
Fuel Flow	40.0 s
Oil-Sample Flow	4.0 s

TABLE 2 Part Numbers for Cat<sup>A</sup> ELC<sup>B</sup> Coolant Concentrate and Premixes

Container Size	3.8 L	19 L	208 L	Tote, <sup>C</sup> 275 g
Concentrate P/N	238-8647	...	...	...
Premix <sup>D</sup> P/N	238-8648	238-8649	238-8650	361-1024

<sup>A</sup> Registered Trademark of Caterpillar Inc., 100 North East Adams St., Peoria, IL 61629.

<sup>B</sup> Trademark of Caterpillar Inc., 100 North East Adams St., Peoria, IL 61629.

<sup>C</sup> A small container.

<sup>D</sup> Equal parts by volume of mineral-free water and coolant concentrate.

6.5 *Oil-Sample Containers*—Preferably use high-density polyethylene containers for oil samples. (Warning—Avoid using glass containers which may break and cause injury or exposure to hazardous materials.)

7. Engine Liquids and Cleaning Solvent

7.1 *Test Oil*—Approximately 115 L of test oil is required to complete the test.

7.2 *Test Fuel*—Approximately 490 L of Chevron Phillips PC-10 ultra-low-sulfur diesel (ULSD) fuel,<sup>14,7</sup> is required to complete the test. Fuel property tolerances are shown in Annex A15.

7.3 *Engine Coolant:*

7.3.1 Use a mixture of equal parts by volume of mineral-free water and Caterpillar-brand, coolant concentrate P/N 238-86476.<sup>6,7</sup>

7.3.2 As an option, premixed coolant is available and may be used directly.

7.3.2.1 Table 2 shows Caterpillar part numbers for several container sizes for concentrate and premixed coolant.

7.3.3 Replace the coolant mixture after 5000 h. The mixture shall remain at equal parts by volume of water and concentrate during the course of the test. Keep the coolant mixture free from contamination.

7.3.4 Maintain a correct additive concentration.

7.4 *Cleaning Solvent*—Use a solvent meeting the requirements of Specification D235, Type II, Class C for volume fraction of aromatics 0 % to 2 %, flash point (61 °C, min), and color (not darker than +25 Saybolt or 25 Pt-Co). Obtain a certificate of analysis for each batch of solvent from the supplier. (Warning—Combustible. Health Hazard. Use adequate safety precautions.)

<sup>11</sup> The sole source of supply of the apparatus known to the committee at this time is Viking Pumps, Inc., 406 State Street, Cedar Falls, IA 50613. www.vikingpump.com.

<sup>12</sup> The sole source of supply of the apparatus known to the committee at this time is J-TEC Associates, Inc., 5005 Blairs Forest Lane NE, Suite L, Cedar Rapids, IA 52402. www.j-tecassociates.com.

<sup>13</sup> Available at: [http://ftp.astmtmc.emu.edu/docs/TechnicalGuidanceCommittee/minutes/BestPractices/DACA\\_II\\_Data%20Acquisition%20and%20Control%20Automation.pdf](http://ftp.astmtmc.emu.edu/docs/TechnicalGuidanceCommittee/minutes/BestPractices/DACA_II_Data%20Acquisition%20and%20Control%20Automation.pdf).

<sup>14</sup> The sole source of supply of the fuel known to the committee at this time is Chevron Phillips Chevron Phillips Chemical Company LP, 10001 Six Pines Drive, Suite 4036B, The Woodlands, TX 77387-4910, www.cpchem.com.

7.5 *Sealant*—Because leached silicon from engine gaskets and sealants can cause elevated aeration levels (see [A12.1](#)), use silicon-free sealants such as alkyl acrylate copolymer (ACM). Loctite<sup>15,7</sup> 5810A (item 39210 or 39211) has been found suitable for this purpose.

## 8. Preparation of Apparatus

### 8.1 *Cleaning of Parts During Rebuild:*

8.1.1 *General*—Preparation of test engine components specific to the Caterpillar C13 engine rebuild are indicated in this section. Use the Caterpillar Service Manual Form SEN R 9700<sup>16</sup> for the preparation of other components (except for the piston second ring—see [8.2.7.1](#)). Take precautions to prevent rusting of iron components. Use of an engine-parts washer followed by a solvent wash is permitted.

8.1.2 *Engine Block*—Disassemble the engine, including removal of the crankshaft, camshaft, piston-cooling tubes, oil pump, and oil-gallery plugs. Thoroughly clean the surfaces and oil passages (galleries). Use a nylon brush to clean the oil passages. Removal of camshaft bearings is optional.

8.1.3 *Cylinder Head, Intake System, and Duct*—Disassemble and clean these components during engine rebuild. Scrub with a nylon brush and solvent. Use of an engine-parts washer followed by a solvent wash is permitted.

8.1.4 *Rocker Cover and Oil Pan*—Clean the rocker cover and oil pan. Use a nylon brush, as necessary, to remove deposits.

8.1.5 *External Oil Mass System*—Flush the internal surfaces of the oil lines and the external reservoir with solvent. Repeat until the solvent drains cleanly. Flush the solvent through the oil pumps until the solvent drains cleanly, then air dry.

8.1.6 *High-Pressure Turbocharger*—Carefully remove the turbine housing from the turbocharger and clean the wastegate valve with solvent and a soft-wire brush.

8.1.7 *Cam-Follower Assembly*—Take the cam-follower assembly apart and inspect the bushings and pins. Replace the parts as necessary.

### 8.2 *Engine Assembly:*

#### 8.2.1 *General:*

8.2.1.1 Perform an engine assembly at the laboratory's discretion. Instances when an engine rebuild should be considered include not meeting operational conditions, or when reference limits cannot be met.

8.2.1.2 Except as noted in this section, use the procedures described in the Caterpillar Service Manual Form SEN R 9700.<sup>16</sup> Assemble the engine with the components shown in the Engine Build Parts List ([Annex A3](#)).

8.2.2 *Parts Reuse and Replacement*—Reuse engine components, except as noted in [8.2.7](#), provided they meet production tolerances as described in the Caterpillar Service Manual.

8.2.3 *Build-up Oils*—For the head, main caps, and rod bolts, use CAT DEO-ULS engine oil<sup>16</sup> as the build-up oil. If test oil is used, the engine build is valid only for the respective test oil.

8.2.4 *Coolant Thermostat*—Lock the engine-coolant thermostat open.

8.2.5 *Fuel Injectors*—Use P/N 239-4908 fuel injectors. If fuel injectors are reused, exercise caution to avoid mechanical damage to or contamination of the nozzles. Dedicate the injectors to a particular cylinder. Install the injectors according to the method described in Caterpillar Service Manual Form SENR9700.<sup>16</sup> Use Mobil EF-411<sup>17,7</sup> engine oil as the build-up oil for the injector o-rings.

8.2.6 *Piston-Cooling Tubes*—Aim the piston-cooling tubes at the underside of the pistons according to the specifications on the TMC website. Contact the TMC for details.

#### 8.2.7 *New Parts:*

8.2.7.1 *General*—The following new parts are included in the Engine Build Parts List. They are not reusable. Clean the parts prior to use. A full rebuild parts list is available from the TMC.<sup>2</sup> For piston second rings, follow the [D7549](#) Piston Second Ring Pre-Test Cleaning Procedure, available from the TMC. During a test, a replacement of any of the new parts listed below will invalidate the test:

##### 8.2.7.2 *List of (Non-Reusable) New Parts:*

- (1) Pistons
- (2) Piston rings (top, second, and oil)
- (3) Cylinder liners
- (4) Valves (intake, exhaust)
- (5) Valve guides
- (6) Valve seats
- (7) Connecting-rod bearings, main bearings, and thrust plate
- (8) Turbochargers
- (9) Oil pump
- (10) Oil-pressure regulator springs located inside of the oil-filter block

#### 8.3 *Operational Measurements:*

8.3.1 *Specified Units and Formats*—See [Annex A8](#).

8.3.1.1 *Measurement of Fuel-Consumption Rate*—Calibrate the system for measuring the fuel-consumption rate before each sequence of reference-oil tests and within six months after completion of the last successful calibration test. Compensate volumetric systems for temperature, and calibrate them against a standard mass-flow device. The flowmeter on the test stand shall agree within 0.2 % of the calibration standard, that standard itself being calibrated against a national standard.

8.3.1.2 *Calibration of Temperature-Measurement System*—Calibrate the temperature-measurement systems before each reference-oil test sequence and within six months after completion of the last successful calibration test. Each temperature-measurement system shall agree within  $\pm 0.5$  °C of the laboratory calibration standard, that standard itself being calibrated against a national standard.

8.3.1.3 *Calibration of Pressure-Measurement System*—Calibrate the pressure-measurement systems before each reference-oil test sequence and within six months after completion of the last successful calibration test. Confirm the calibration standard against a national standard.

<sup>15</sup> Loctite is a registered trademark of Henkel Corp., 26235 First Street, Westlake, OH 44145.

<sup>16</sup> Available from a Caterpillar parts distributor.

<sup>17</sup> The sole source of this oil known to the committee at this time is Exxon-Mobil Oil Corp., P.O. Box 66940, AMF O'Hare, IL 60666, Attention Illinois Order Board.



#### 8.3.1.4 Calibration of FDM:

(1) Calibrate the Micro Motion FDM at least once a year. Emerson's Flow Calibration and Service Centers<sup>18</sup> have been found satisfactory for this purpose.

(2) For all reference- and non-reference-oil tests to be considered valid, the FDM shall have a current calibration.

(3) Calibrate the FDM if there are concerns with the accuracy of the density or flow measurements.

(4) A procedure for checking the accuracy of the FDM-determined densities is described in 10.4.

#### 8.3.2 Locations for Temperature-Measurement Sensors:

8.3.2.1 *General*—The measurement equipment is not specified. Install the sensors such that the tip is located midstream of the flow unless otherwise indicated. The accuracy and measurement of the temperature-measurement sensors and the complete measurement system shall follow the guidelines in ASTM Research Report RR:D02-1218.<sup>13, 19</sup>

8.3.2.2 *Coolant-Out Temperature*—Install the sensor in the fitting on the thermostat housing (Fig. A5.13).

8.3.2.3 *Coolant-In Temperature*—Install the sensor on the right side of the coolant-pump intake housing at the 1 in. NPT port (Fig. A5.14).

8.3.2.4 *Fuel-In Temperature*—Install the sensor in the fuel-pump inlet fitting (Fig. A5.16).

8.3.2.5 *Oil-Gallery Temperature*—Install a 1/8 in. thermocouple at the sensor at the 3/8 in. NPT female boss on the right-rear of the engine (Fig. A5.15) extending from the cross fitting described in A7.2.1 to the center of the oil gallery flow.

8.3.2.6 *Intake-Air Temperature*—Install the sensor in the inlet air tube 127 mm upstream of the compressor connection (Fig. A5.7).

8.3.2.7 *Intake-Manifold Temperature*—Install the sensor at the 1/8 in. NPT female boss on the outside radius of the inlet-manifold elbow (Fig. A5.17).

8.3.2.8 *Exhaust Temperature*—Install the sensor in the exhaust tube (Fig. A5.8).

8.3.2.9 *Aeration-System-Enclosure Temperature*—Insert the sensor 75 mm directly above the vertical centerline of the Micro Motion FDM and extending into the enclosure to the vertical plane of the FDM face.

8.3.2.10 *Oil-Sump Temperature*—Insert a thermocouple to a depth of 50 mm into the drain-plug port on the right-front pan pictured in Fig. A5.5.

8.3.2.11 *Additional Temperatures*—It is permissible to measure any additional temperatures that may be useful for test operation or engine diagnostics.

NOTE 4—Additional exhaust-sensor locations, at the exhaust ports and pre-turbine (front and rear), are recommended. The detection of changes in exhaust temperatures is an important diagnostic feature.

#### 8.3.3 Locations for Pressure-Measurement Sensors:

8.3.3.1 *General*—The measurement equipment is not specified. Follow the guidelines in ASTM Research Report RR:D02-1218<sup>13, 19</sup> for the accuracy and resolution of the

pressure-measurement sensors and the complete measurement system. If the laboratory has problems with condensation forming in the pressure lines, install a condensation trap at the lowest elevation of the tubing between the pressure-measurement location and the final pressure sensor for crankcase pressure, intake-air pressure, and exhaust pressure. Route the tubing to avoid intermediate loops or low spots before and after the condensation trap.

8.3.3.2 *Oil-Gallery Pressure*—Measure the pressure from the upper vertical port of the 3/8 in. 4-way cross fitting on the right rear of the engine (Fig. A5.15).

8.3.3.3 *Oil-Filter-Inlet Pressure*—Measure the pressure at the plug located on the inlet side of the oil filter assembly (Fig. A5.9).

8.3.3.4 *Inlet-Manifold Pressure*—Measure the pressure at the 1/4 in. NPT port on the outside radius of the inlet-manifold elbow (Fig. A5.17).

8.3.3.5 *Crankcase Pressure*—Measure the pressure by installing a bulkhead fitting in the top of the valve cover. (Fig. A5.12).

8.3.3.6 *Intake-Air Pressure*—Measure the pressure at a wall tap on the intake-air tube 153 mm upstream of the compressor connection (Fig. A5.7).

8.3.3.7 *Exhaust Pressure*—Measure the pressure on the exhaust tube (Fig. A5.8).

8.3.3.8 *Fuel Pressure*—Measure the pressure at the fuel-filter head (Fig. A5.25).

8.3.3.9 *Coolant Pressure*—Measure the pressure on top of the expansion tank (Fig. X1.3).

8.3.3.10 *Intercooler Delta Pressure*—Measure the pressure drop across the intercooler. Measure the intercooler inlet pressure at the elbow outlet of the CAT charge air cooler (Fig. A5.19). Use the intake-manifold pressure (8.3.3.4) as the intercooler outlet pressure. The intercooler delta pressure is the difference between the intercooler outlet pressure and the intercooler inlet pressure.

8.3.3.11 *Additional Pressures*—It is permissible to measure any additional pressures that may be useful for test operation or engine diagnostics.

NOTE 5—See Figs. A5.19 and A5.20 for additional instrument placement information.

#### 8.3.4 Locations for Flow-Rate Measurement:

8.3.4.1 *General*—The equipment for fuel-rate measurements is not specified. Follow the guidelines in ASTM Research Report RR:D02-1218<sup>13</sup> for the accuracy and resolution of the flow-rate-measurement system.

8.3.4.2 *Blowby*—Measure the blowby flow rate using a JTEC model VF563A or VF563B. See 6.3.11 for blowby measurement system configuration.

8.3.4.3 *Fuel Flow*—Determine the fuel consumption rate by measuring the fuel flowing to the day tank (Fig. X1.2).

8.3.5 *Controller Outputs and Indications of Malfunction in the Aeration-Measurement System*—Record the controller output as % for the sample pressure control regulator. If this value is above 50 % for 15W-40 or lower viscosity oils (that is, for oils with kinematic viscosity at 100 °C less than 12.5 mm<sup>2</sup>/s)

<sup>18</sup> Emerson Process Management Micro Motion Americas, 7070 Winchester Circle, Boulder, CO 80301. www.flowsupport@emerson.com.

<sup>19</sup> Supporting data have been filed at ASTM International Headquarters and may be obtained by requesting Research Report RR:D02-1218. Contact ASTM Customer Service at service@astm.org.



the test is invalid. Oils of higher viscosity need a statement of validity in the comments section of the report if the controller output exceeds 50 %.

8.3.6 *Quantities for Aerated-Oil Samples*—Measure temperature, pressure, flow rate, and density using the aeration system shown in [Annex A7](#).

8.3.6.1 Record the oil sample temperature as the average of the inlet- and outlet-thermocouple temperatures of the FDM. (This temperature is a theoretical temperature at the midpoint of the FDM.)

8.3.6.2 Record the oil sample pressure as the average of the inlet- and outlet-pressure transducers of the FDM. (This pressure is a theoretical pressure at the midpoint of the FDM.)

## 9. Engine/Stand Calibration and Non-Reference-Oil Tests

9.1 [Annex A9](#) describes calibration procedures using the TMC reference oils, including their storage and conditions of use, the conducting of tests, and the reporting of results.

9.2 [Annex A10](#) describes maintenance activities involving TMC reference oils, including special reference-oil tests, special use of the reference-oil calibration system, donated reference-oil test programs, introducing new reference oils, and TMC information letters and memoranda.

9.3 [Annex A11](#) provides information regarding new laboratories, the role of the TMC regarding precision data, and the calibration of test stands used for non-standard tests.

### 9.4 *Stand Calibration:*

9.4.1 Calibrate the test stand by conducting a test with a blind reference oil (see [A9.2](#)). Submit the results to the TMC as described in [A9.6](#). Determine the acceptability of a reference-oil test according to the LTMS.

9.4.2 *New Test Stand*—A new test stand is one that has never been calibrated or has not completed an acceptable reference-oil test within 24 months of the end of test (EOT) date of the last acceptable reference-oil test. Perform a calibration as described in [9.4.1](#) to introduce a new test stand.

9.4.3 *Stand-Calibration Period*—The calibration period is 6 months and a certain number of operationally valid non-reference-oil tests, whichever comes first, from the EOT date of the last acceptable reference-oil test. The number of non-reference-oil tests allowed during a calibration period is determined by the number of reference-oil tests that have been completed on a test stand. The first calibration period on a new stand is six months or two non-reference-oil tests, whichever comes first. The second calibration period on a stand is six months or four non-reference-oil tests. The third calibration period on a stand is six months or six tests. The fourth and all subsequent calibration periods on a test stand is six months or nine tests.

9.4.4 *Stand Modification and Calibration Status*—Stand-calibration status will be invalidated by conducting any non-standard test or modification of the test and control systems, or both. A non-standard test is any test conducted under a modified procedure, or using non-procedural hardware, or using controller-set-point modifications, or any combination thereof. Any such changes terminate the current calibration period. A reference test is required before restarting the current

calibration period (see [A9.2.2](#)). If changes are contemplated, contact the TMC beforehand to ascertain the effect on the calibration status.

### 9.5 *Test-Numbering System:*

9.5.1 The test number for both reference and non-reference oils has three parts: X, Y, and Z, where X represents the test-stand number, Y the sequential test-stand-run number, and Z the number of hours run on the stand since the last reference-oil test. For example 27-15-150 indicates run number 15 on test-stand number 27, the test stand having been run for 150 h since the last reference-oil test. The test stand run number, Y, will increase sequentially by one for each test start (reference oil or non-reference oil). A letter suffix may also be necessary (see [9.5.2](#)).

9.5.2 A reference-oil test conducted subsequent to an unacceptable reference-oil test shall include a letter suffix after Y. The letter suffix shall begin with A and incremented alphabetically until acceptable reference-oil test is completed. For example, if two consecutive unacceptable reference-oil tests were conducted and the first number was 27-15-150, the second test number would be 27-16A-150. A third calibration attempt would have the test number 27-17B-150. If the third test were acceptable, then 27-17B-150 would identify the reference-oil test in the test report.

9.5.3 *Non-Reference-Oil Tests*—Add no letter suffix to Y for aborted or operationally invalid non-reference-oil tests.

9.6 *Reference-Oil Tests*—Carry out reference-oil tests as described in [A9.5](#) and report the results to the TMC as described in [A9.6](#). Determine the acceptability of a reference-oil test according to the LTMS.

9.7 *Non-Reference-Oil Tests: Last Start Date*—When running non-reference-oil tests during the calibration period, crank the engine prior to the expiration of the calibration period ([9.4.3](#)).

## 10. Procedure

### 10.1 *Engine Break-in and Silicon Passivation:*

10.1.1 Following the engine assembly, install the engine on the stand and connect the engine to the stand support system.

10.1.2 Carry out the engine break-in as described in [Annex A12](#).

10.1.2.1 *Shutdown During Break-in*—If a shutdown occurs during the break-in, resume the break-in from the point at which the shutdown occurred. Record such an occurrence in “Other Comments” on the appropriate report form.

NOTE 6—Use the break-in as an opportunity to confirm engine performance and to make repairs prior to the start of the 50 h test procedure.

10.1.3 After completion of the engine break-in, shut the engine down, using the normal shutdown procedure described in [10.3.1](#).

10.1.4 Drain the oil and remove the oil filter.

NOTE 7—After the engine has performed the break-in, it can be transferred to the stand equipped with the aeration measurement system and instrumented according to this procedure. Alternatively, both the break-in and the aeration testing can be carried out on the same stand provided as it can meet the break-in procedure conditions and can also

maintain the operation conditions defined in this procedure for aeration testing.

### 10.2 Aeration Pretest Procedure:

10.2.1 Install a new Caterpillar 1R-1808 oil filter.<sup>16</sup>

10.2.2 Charge the engine with 32.2 L ± 0.2 L of test oil.

10.2.2.1 Use the pressurized, oil-fill system described in 6.3.8 or charge manually through the engine-oil, add-tube.

10.2.3 Warmup—Start the engine and perform the warmup described by Steps 1 and 2 of Table 3. After completion of Step 2, perform a 2 min cool-down at Step 1 conditions before shutting down the engine.

10.2.4 Drain the engine of the initial oil charge while allowing the oil sampling circuit pump to run and drain.

10.2.5 Repeat 10.2.2 to 10.2.4.

10.2.5.1 Install a new Caterpillar 1R-1808 oil filter.

10.2.5.2 Charge the engine with 36 L ± 0.2 L of test oil and perform the warmup as described in Table 3 before continuing to on-test conditions as described in 10.5.

10.3 Shutdowns and Maintenance—The test may be shut-down at the discretion of the laboratory to perform repairs. However, the intent of this test method is to conduct the 50 h test procedure without shutdowns. Shutdowns between 30 h and 50 h test time invalidate the test. This period is critical for accurate measurement of the aeration average from 40 h to 50 h.

10.3.1 Normal Shutdown—A normal shutdown is accomplished by ramping down to warmup Step 1 conditions (Table 3), running for 2 min, and then stopping the engine.

10.3.2 Emergency Shutdown—An emergency shutdown occurs when the normal shutdown cannot be completed, such as under an alarm condition. During an emergency shutdown ignition can be turned off immediately and the engine allowed to stop. Such an occurrence is described in “Other Comments” of the appropriate report form (see 12.1).

10.3.3 Maintenance—Engine components or stand support equipment or both may be repaired or replaced at the discretion of the laboratory and in accordance with this test method. It is recommended to monitor the condition of the oil pressure regulator springs within the oil filter housing. These springs may require replacement if the oil gallery pressures are not typical.

10.3.4 Downtime—The limit for total downtime is not specified. Record on the appropriate report form all shutdowns, pertinent actions, and total downtime during the 50 h test procedure. Downtime is calculated as the period between the engine leaving on-test and until it returns to on-test. Warmup periods are included in the downtime period.

10.3.5 Engine Restarting—Each time the engine is restarted, perform the warmup described in 10.2.3 before proceeding onto test.

### 10.4 Determination of Baseline Densities:

10.4.1 General—The percent aeration of the test oil is based on a comparison of the densities of the fresh, un-aerated oil and the aerated oil sampled during the engine operation (see 11.1). To eliminate the effects of temperature on the density results, all densities are calculated at a reference temperature of 90 °C. For this purpose, the temperature dependence of the density of the un-aerated fresh oil is determined by Test Method D4052 and is used to calculate the density at 90 °C of the both the un-aerated fresh oil and the aerated sample oil. The D4052 density of the un-aerated fresh oil and its temperature dependence are referred to as baseline (BL) values and are determined after completion of the pretest procedure described in 10.2 and before carrying out the 50 h test procedure described in 10.5.

10.4.2 Baseline D4052 Density of Unaerated Fresh Oil and its Temperature Dependence:

10.4.2.1 Measure the density of the fresh test oil between 30 °C to 90 °C at 10 °C increments using Test Method D4052.

10.4.2.2 Use these seven data points to calculate the first order, linear regression of density versus temperature using the least squares method. R<sup>2</sup> values shall be greater than 0.99990. Repeat the density measurements as necessary until the required value is obtained.

10.4.2.3 The slope of this line quantifies the effect of temperature on the D4052 density of the fresh, un-aerated oil and is denoted by  $\frac{d}{dT} \rho_{BL}$ ; the intercept at 90 °C is the D4052 density of the un-aerated fresh oil at 90 °C and is denoted by  $\rho_{BL,90}$ . (Here  $\rho$  and  $T$  are used as the symbols for density and temperature, respectively, and BL denotes “baseline.”)

NOTE 8—For convenience, a list of the quantity symbols and their definitions is given in 3.4.

### 10.5 50 h Test Procedure:

10.5.1 Following on from 10.2.5, measure out 36 L ± 0.2 L of test oil and determine the mass. Record the volume and mass of the oil. Charge the engine as described in 10.2.2.1.

10.5.2 Start the engine and carry out the warmup described in 10.2.3.

10.5.3 Immediately after completing the warmup and without shutting down the engine, start the 50 h test procedure described in Table 4.

**TABLE 3 Warmup Conditions**

Quantity, units	Step 1	Step 2
Stage Length, min	5	35
Speed, r/min	900	1800
Load, N·m	0	0
Coolant Out Temperature, <sup>A</sup> °C	90	90
Intake Air Temperature, <sup>A</sup> °C	25	25
Manifold Temperature, <sup>A</sup> °C	40	40
Fuel Temperature, <sup>A</sup> °C	40	40
Gallery Oil Temperature, <sup>A</sup> °C	90	90
Sample Oil Temperature, <sup>A</sup> °C	90	90
Sample Oil Flow Rate, <sup>A</sup> L/min	1.5	1.5
Sample Oil Pressure, <sup>A</sup> kPa (absolute)	150	150
Intake Air Pressure, <sup>A</sup> kPa (absolute)	96	96
Fuel Flow Rate, g/min	Record	Record
Blowby Flow Rate, L/min	Record	Record
Intake Manifold Pressure, <sup>B</sup> kPa (gauge)	Record	Record
Exhaust After Turbo Temperature, °C	Record	Record
Fuel Pressure, kPa (gauge)	Record	Record
Oil Gallery Pressure, kPa (gauge)	Record	Record
Coolant System Pressure, kPa (gauge)	100	100
Exhaust Restriction Pressure, kPa (absolute)	104	104
Crankcase Pressure, kPa (absolute)	103	103
Aeration Enclosure Temperature, °C	50	50

<sup>A</sup> This is the control set-point. It can require up to 30 min of operation to achieve.

<sup>B</sup> With turbocharger waste-gate fully closed.

**TABLE 4 Schedule of Conditions for the 50 h Test**

Quantity, units	Step 1
Stage Length, h	50
Speed, r/min	1800
Load, N·m	0
Coolant Out Temperature, °C	90
Air Intake Temperature, °C	25
Intake Manifold Temperature, °C	40
Fuel-in Temperature, °C	40
Oil Gallery Temperature, °C	90
Sample Oil Temperature, <sup>A</sup> °C	90
Sample Oil Flow Rate, <sup>A</sup> L/min	1.5
Sample Oil Pressure, <sup>A</sup> kPa (absolute),	84
Intake Air Pressure, kPa (absolute),	96 ± 1.5
Fuel Flow Rate, g/min	Record
Blowby Flow Rate, L/min	Record
Intake Manifold Pressure, <sup>B</sup> kPa (gauge)	Record
Crankcase Pressure, kPa (gauge)	103
Intercooler Delta Pressure, kPa (gauge)	15 max
Exhaust After Turbo Temperature, °C	Record
Fuel Pressure, kPa (gauge)	Record
Oil Gallery Pressure, kPa (gauge)	Record
Coolant System Pressure, kPa (gauge)	99 to 107
Exhaust Restriction Pressure, kPa (absolute)	104
Pressure Regulator Controller Output, <sup>C,D</sup> %	<50 %
Micro pump Controller Output, <sup>C,D</sup> %	<50 %

<sup>A</sup> Micro Motion quantity.

<sup>B</sup> With turbocharger waste-gate fully closed.

<sup>C</sup> If this value is above 50 % output for 15W-40 or thinner viscosity oils, the test is invalid. Oils of higher viscosity need a statement of validity in the comments section of the report if they exceed 50 % output.

<sup>D</sup> Average value over the length of the test.

**10.5.3.1 Test Timer**—The 50 h test timer starts immediately following the warmup. If a shutdown occurs, stop the test timer immediately at the initiation of the shutdown. The test timer shall resume after the warmup described in **Table 3** and when the test has been returned to the test operation schedule and all controlled quantities are within specification requirements.

**10.5.4 Operational Data Acquisition**—Record all operational quantities shown in **Table 4** with automated data acquisition at a minimum frequency of once every 30 s. Recorded values shall have a minimum resolution in accordance with **Annex A8**.

**10.5.4.1** Record the operational data on the appropriate test report form.

#### 10.5.5 Oil Sampling and Analyses:

**10.5.5.1 New Oil Sample**—Take a 240 mL sample of the fresh test oil from the original oil container. Measure and report the quantities shown **A14.2**.

**10.5.5.2** Take oil samples and carry out analyses according to the schedule and methods shown in **Annex A13**.

**10.5.5.3** Record the results on the appropriate test report form.

#### 10.5.6 Quantities for Aerated Oil Samples:

**10.5.6.1 General**—Measure the sample oil temperature, pressure, flow rate, and FDM density using the aeration system shown in **Fig. A7.1**.

**10.5.6.2 Temperature of Sampled Oil**—Record the average of the inlet and outlet thermocouple temperatures of the FDM. This temperature is a theoretical temperature at the midpoint of the FDM; it is referred to as the sample oil temperature and is denoted by  $T_{\text{SAMPLE}}$ .

**10.5.6.3 Pressure of Sampled Oil**—Record the average of the inlet and outlet pressure transducers of the FDM. This pressure is a theoretical pressure at the midpoint of the FDM; it is referred to as the sample oil pressure and is denoted by  $P_{\text{SAMPLE}}$ .

**10.5.6.4 FDM Density of Sampled Oil**—Record the sample oil density. This is the density of the aerated oil at the temperature  $T_{\text{SAMPLE}}$  and the pressure  $P_{\text{SAMPLE}}$ ; it is denoted by  $\rho_{\text{SAMPLE}}$ .

**10.5.7** After completion of the 50 h test perform a normal shutdown as described in **10.3.1**.

**10.5.8** Drain the test oil charge from the engine with the oil sample circuit pump running, weigh the drained oil and calculate the total oil consumed during the test as the difference in mass between the initial charge (as recorded in **10.5.1**) and the drained oil.

## 11. Calculation

### 11.1 Oil Aeration Calculations:

**11.1.1** Calculate the percent oil aeration from the quantities recorded in **10.5.6** as follows:

**11.1.1.1** First, using **Eq 2**, calculate  $\rho_{\text{SAMPLE},90}$ , the FDM density of the aerated-oil sample at 90 °C:

$$\rho_{\text{SAMPLE},90} = \rho_{\text{SAMPLE}} + (90 - T_{\text{SAMPLE}}) \times \frac{d}{dT} \rho_{\text{BL}} \quad (1)$$

where:

$\rho_{\text{SAMPLE}}$  = the recorded density of the aerated oil sample at the temperature  $T_{\text{SAMPLE}}$  (see **10.5.6.4**),  
 $T_{\text{SAMPLE}}$  = the sample oil temperature (see **10.5.6.2**), and  
 $\frac{d}{dT} \rho_{\text{BL}}$  = the temperature dependence of the baseline density (see **10.4.2.3**).

**11.1.1.2** Then, using **Eq 3**, calculate the air density,  $\rho_{\text{AIR}}$ , at the temperature and pressure,  $T_{\text{SAMPLE}}$  and pressure  $P_{\text{SAMPLE}}$ , respectively, of the oil sample:

$$\rho_{\text{AIR}} = \rho_{\text{SAMPLE}} / [287.003 \times (T_{\text{SAMPLE}} + 273.15)] \quad (2)$$

where:

$\rho_{\text{SAMPLE}}$  = the pressure of the sampled oil determined as described in **10.5.6.3**,  
 273.15 = the ice point in °C and,  
 287.003 = the specific gas constant for dry air with units  $\text{Jkg}^{-1}\text{K}^{-1}$ , where K is the symbol for kelvin.

**11.1.1.3** Finally, using **Eq 4**, calculate the oil aeration:

$$OA = [(\rho_{\text{BL},90} - \rho_{\text{SAMPLE},90}) / (\rho_{\text{SAMPLE},90} - \rho_{\text{AIR}})] \times 100 \% \quad (3)$$

where:

OA = the symbol denoting oil aeration,  
 $\rho_{\text{BL},90}$  = the **D4052** baseline density of the unaerated fresh oil at 90 °C (see **10.4.2.3**), and

$\rho_{\text{SAMPLE},90}$  and  $\rho_{\text{AIR}}$  are given by **Eq 2** and **Eq 3**, respectively.

**11.1.2** Calculate the average oil aeration from 40 h to 50 h by taking the average of all values calculated in **11.1.1.3** from test hours 40 through 50. Report on the appropriate test report form. Report the percent oil aeration to two decimal places.



## 12. Report

12.1 For reference-oil results, use the standardized report form set available from the ASTM TMC and data dictionary for reporting test results and for summarizing operational data.

NOTE 9—Report the non-reference-oil test results on these same forms if the results are intended to be submitted as candidate oil results against a specification.

12.1.1 Fill out the report forms according to the formats shown in the data dictionary.

12.1.2 Transmit results to the TMC within five working days of test completion.

12.1.3 Transmit the results electronically as described in the ASTM Data Communications Committee Test Report Transmission Model (Section 2—Flat File Transmission Format) available from the ASTM TMC. Upload files via the TMC’s website.

12.2 Report all reference-oil test results, whether aborted, invalidated, or successfully completed, to the TMC.

12.3 *Deviations from Test Operational Limits*—Report all deviations from specified test operational limits.

12.4 *Precision of Reported Units*—Use the Practice E29 rounding-off method for critical pass/fail test result data. Report the data to the same precision as indicated in data dictionary.

12.5 In the space provided, note the time, date, test hour, and duration of any shutdown or off-test condition. Document the outcome of all prior reference-oil tests from the current calibration sequence that were operationally or statistically invalid.

12.6 If a calibration period is extended beyond the normal calibration period length, make a note in the comment section and attach a written confirmation of the granted extension from the TMC to the test report. List the outcomes of previous runs that may need to be considered as part of the extension in the comment section.

## 13. Precision and Bias

### 13.1 Precision:

13.1.1 Test precision is established on the basis of operationally valid reference-oil test results monitored by the TMC.

13.1.2 *Intermediate Precision Conditions*—Conditions where test results are obtained with the same test method using the same test oil, with changing conditions such as operators, measuring equipment, test stands, test engines, and time.

NOTE 10—Intermediate Precision is the appropriate term for this test method, rather than repeatability, which defines more rigorous within-laboratory conditions.

13.1.2.1 *Intermediate Precision Limit (i.p.)*—The difference between two results obtained under intermediate precision conditions that in the long run, in the normal and correct conduct of the test method, exceed the value shown in Table 5 in only one case in twenty. When only a single test result is available, the intermediate precision limit can be used to calculate a range (test result plus/minus intermediate precision limit) outside of which a second test result would be expected to fall about one time in twenty.

13.1.3 *Reproducibility Conditions*—Conditions where test results are obtained with the same test method using the same test oil in different laboratories with different operators using different equipment.

13.1.3.1 *Reproducibility Limit (R)*—The difference between two results obtained under reproducibility conditions that would, in the long run, in the normal and correct conduct of the test method, exceed the values in Table 5 in only one case in twenty. When only a single test results is available, the reproducibility limit can be used to calculate a range (test result plus/minus reproducibility limit) outside of which a second test result would be expected to fall about one time in twenty.

13.1.4 The test precision for the COAT as of February 10, 2016 is shown in Table 5. The TMC updates precision data frequently, and this information can be obtained by contacting the TMC.

13.2 *Bias*—Bias is determined by applying an accepted statistical technique to reference-oil test results and, when a significant bias is determined, a severity adjustment is permitted for non-reference-oil test results (refer to the TMC for details).

## 14. Keywords

14.1 automotive; Caterpillar C13; COAT; diesel engine oil; heavy-duty diesel engine; lubricants; oil aeration

**TABLE 5 Test Precision for COAT<sup>A</sup>**

Quantity	Intermediate Precision, <i>i.p.</i>	Reproducibility, <i>R</i>
Average Engine Oil Aeration from 40 h to 50 h, %	0.743	0.858

<sup>A</sup> These statistics are based on 33 tests conducted on three stands (one at each of three laboratories) on six ASTM TMC Reference Oils (832, PC11H, PC11I, PC11J, 833, PC11L) and were calculated on February 10, 2016.

**ANNEXES****(Mandatory Information)****A1. ASTM TEST MONITORING CENTER ORGANIZATION**

*A1.1 Nature and Functions of the ASTM Test Monitoring Center (TMC)*—The TMC is a non-profit organization located in Pittsburgh, Pennsylvania and is staffed to: administer engineering studies; conduct laboratory inspections; perform statistical analyses of reference-oil test data; blend, store, and ship reference oils; and provide the associated administrative functions to maintain the referencing calibration program for various lubricant tests as directed by ASTM Subcommittee D02.B0 and the TMC Executive Committee. The TMC coordinates its activities with the test sponsors, the test developers, the surveillance panels, and the testing laboratories. Contact TMC through the TMC Director at:

ASTM Test Monitoring Center  
6555 Penn Avenue  
Pittsburgh, PA 15206-4489  
[www.astmtmc.cmu.edu](http://www.astmtmc.cmu.edu)

*A1.2 Rules of Operation of the ASTM TMC*—The TMC operates in accordance with the ASTM Charter, the ASTM Bylaws, the Regulations Governing ASTM Technical Committees, the Bylaws Governing ASTM Committee D02, and the Rules and Regulations Governing the ASTM Test Monitoring System.

*A1.3 Management of the ASTM TMC*—The management of the Test Monitoring System is vested in the Executive Committee elected by Subcommittee D02.B0. The Executive Committee selects the TMC Director who is responsible for directing the activities of the TMC.

*A1.4 Operating Income of the ASTM TMC*—The TMC operating income is obtained from fees levied on the reference oils supplied and on the calibration tests conducted. Fee schedules are established by the Executive Committee and reviewed by Subcommittee D02.B0.

**A2. SAFETY PRECAUTIONS**

*A2.1* The operation of engine tests may expose personnel and facilities to safety hazards. Personnel trained and experienced with engine testing shall perform the design, installation, and operation of the test stands.

*A2.2* Install guards (shields) around all external moving, hot, or cold components. Design the guard to contain the energy level of a rotating component should the component break free. Properly route fuel, oil, and electrical wiring, and guard, ground, and keep in good order.

*A2.3* Keep the test stand free of oil and fuel spills and tripping hazards. Do not permit containers of oil or fuel, or both, to accumulate in the testing area. Fire fighting equipment shall be immediately accessible. Observe normal precautions whenever using combustible solvents for cleaning purposes.

*A2.4* Safety masks, glasses, or hearing protection, or a combination thereof, shall be worn by personnel working on the test stand. Do not wear loose or flowing clothing, including

neither long hair nor other accessory to dress, near rotating equipment. Caution personnel against working alongside the engine and driveline while the engine is running.

*A2.5* Interlocks shall automatically shut down the engine when an anomaly in any of the following occurs: engine or dynamometer coolant temperature, engine oil pressure, dynamometer field current, engine speed, exhaust temperature, excessive vibration, or when the fire protection system is activated. The interlock shall include a method to cut off the fuel supply to the engine at the injector pipe (including the return line). A remote fuel cutoff station (external to the test stand) is recommended.

*A2.6* Employ other safety precautions as required by regulations.

### A3. ENGINE AND ENGINE BUILD PARTS KIT

A3.1 Obtain the Caterpillar C13 Engine Arrangement Number 244-4803 or 249-8361 by contacting the Caterpillar Oil Test Engine Representative. Current contact information is maintained at the ASTM TMC.<sup>2</sup>

A3.2 Critical parts are shown in **Table A3.1**.

A3.2.1 Obtain critical parts by contacting the Caterpillar Oil Test Engine Representative. Current contact information is maintained at the TMC.<sup>2</sup>

A3.3 A list of non-critical engine build parts and their current part numbers is available from the TMC. Obtain the parts directly from a Caterpillar dealer.

**TABLE A3.1 Engine Build Parts (Critical)**

Item	Part Number
Gasket, silicon free – Oil Pan <sup>A,B</sup>	481-7229
Gasket, silicon free – Rocker Cover <sup>A,C</sup>	481-7230
Piston	1Y-4106
Liner – Cylinder	1Y-4107
Ring – Top	1Y-4108
Ring – Intermediate	1Y-4109
Ring – Oil	1Y-4110
Valve – Intake	224-3028
Valve – Exhaust	224-3030
Valve Guide	259-2186
Valve Seat – Intake	224-2410
Valve Seat – Exhaust	224-1270
Connecting Rod Bearing	116-1089
Main Bearing	211-0587 and 211-0588
Thrust Plate	1Y4118 or 116-1107
Turbocharger (Low Pressure)	239-5581
Turbocharger (High Pressure)	284-7707
Oil Pressure Regulator Spring	7C-3954
Oil Pump By Pass Valve	224-3405
Oil Pan Jacket	1364344

<sup>A</sup> This is a silicon-free part which contributes to reducing the silicon-passivation time (see **Annex A12**).

<sup>B</sup> Fabricate a spacer conforming to P/N 489-7398, the prints for which are available from the TMC.<sup>2</sup>

<sup>C</sup> Fabricate a spacer conforming to P/N 489-7397, the prints for which are available from the TMC.<sup>2</sup>



#### A4. OIL TEMPERATURE CONTROL SYSTEM

A4.1 *System Details*—See Figs. A4.1-A4.4 for details of the auxiliary oil heat exchanger setup.

A4.2 *Heat Exchanger*—Use an ITT Standard SSCF heat exchanger, P/N SN5160030014004.

A4.3 *Oil Lines and Fittings*—Use two size No. 16 oil lines with a maximum length of 914 mm (total of both lines), preferably made from stainless steel braided hose. Use size No.16 NPT threaded fittings for the line connections.

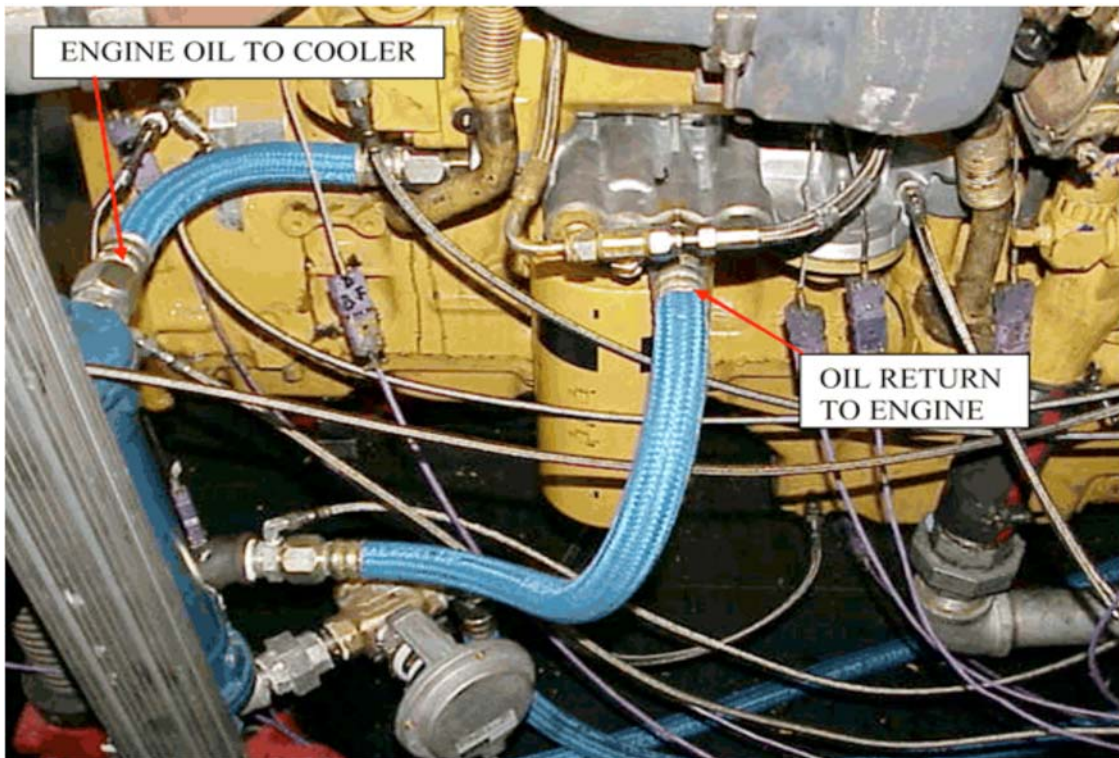

FIG. A4.1 Remote Oil Heat Exchanger

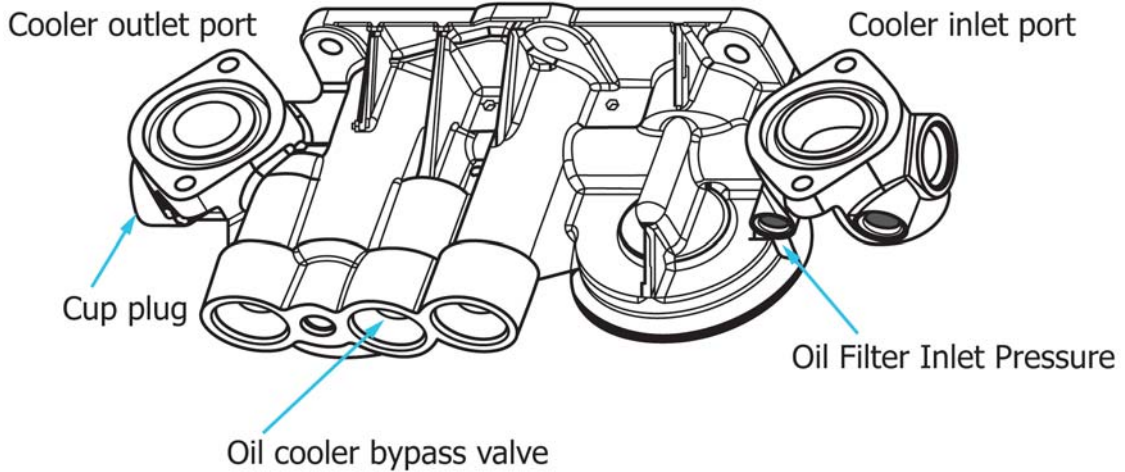

FIG. A4.2 Filter Base (P/N 251-6668) View

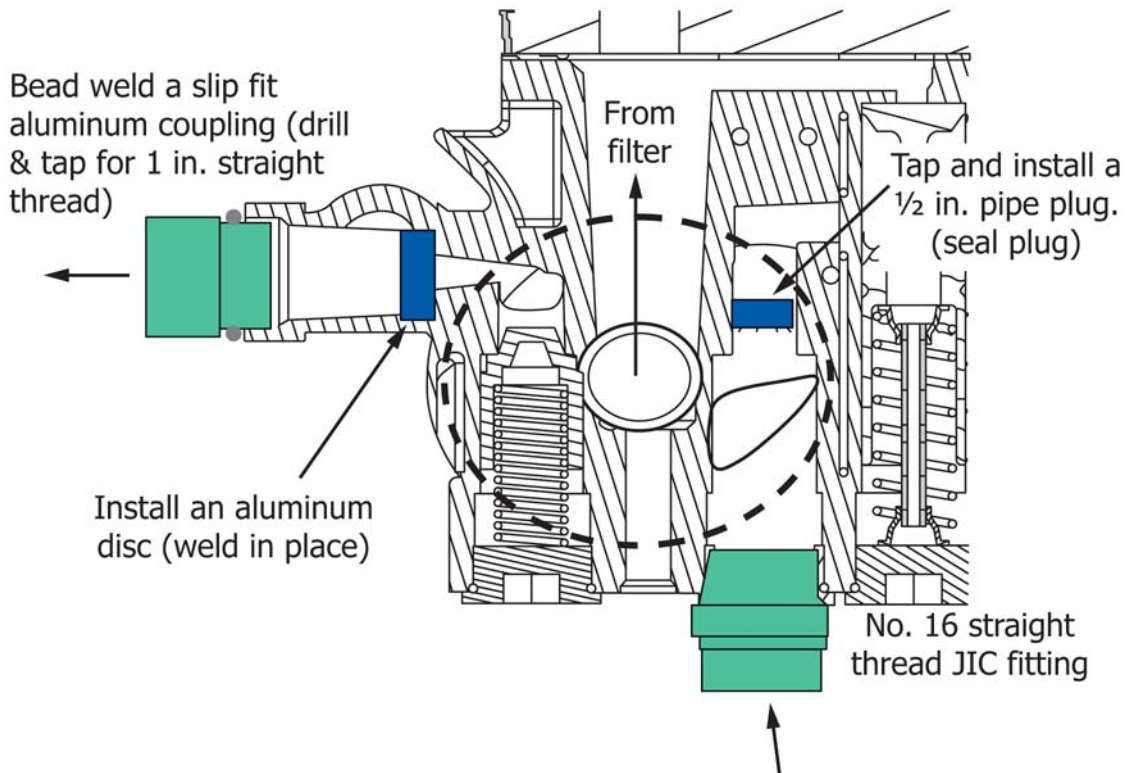
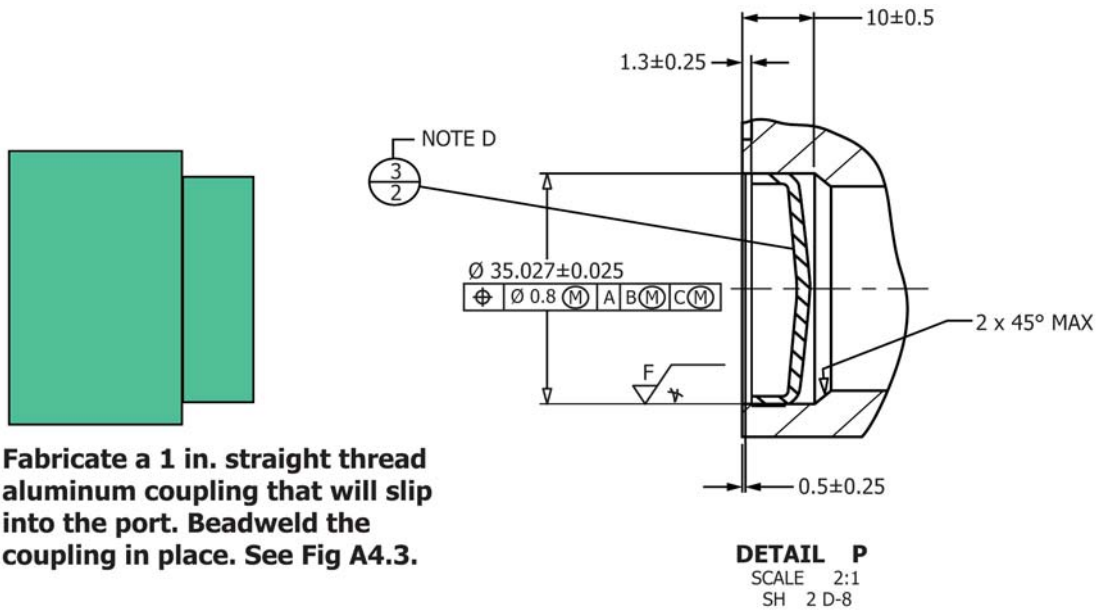

FIG. A4.3 Filter Base Modifications



NOTE 1—Dimensions are in millimeters unless otherwise stated.

FIG. A4.4 Details of Cup Plug Feature at Back End of Filter Base

## A5. ENGINE MODIFICATIONS AND INSTRUMENTATION

A5.1 Engine modifications and instrumentation are shown in [Figs. A5.1-A5.25](#).



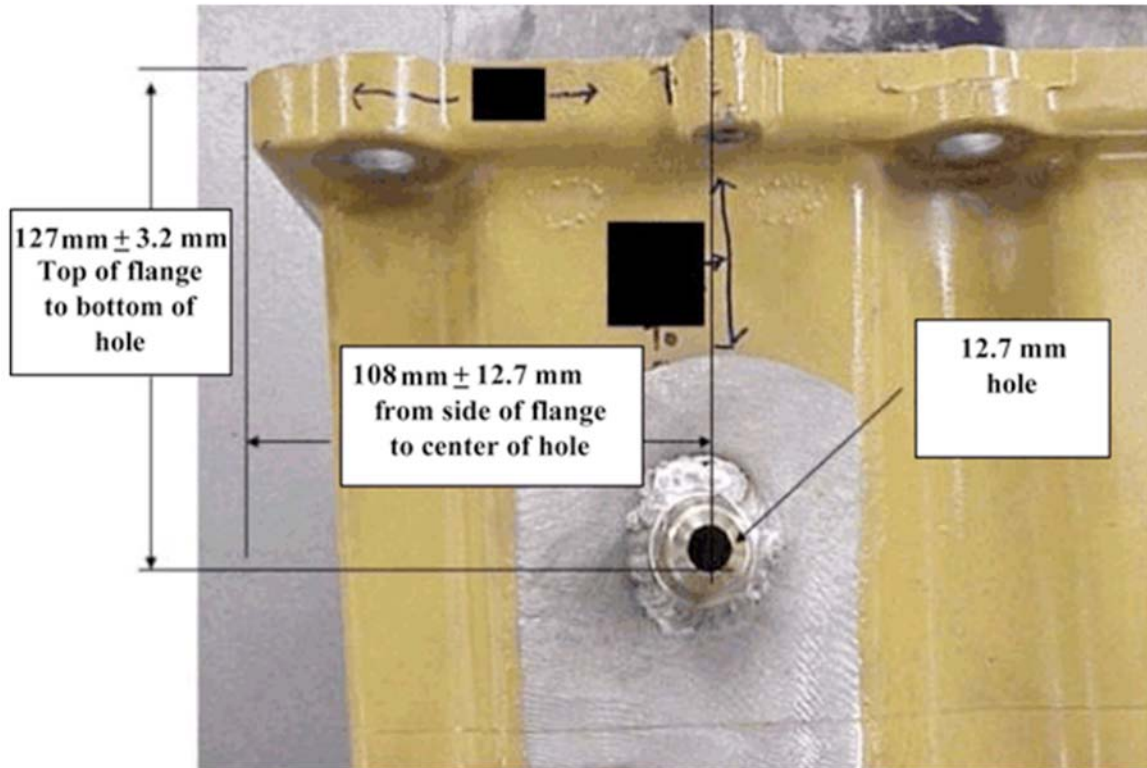
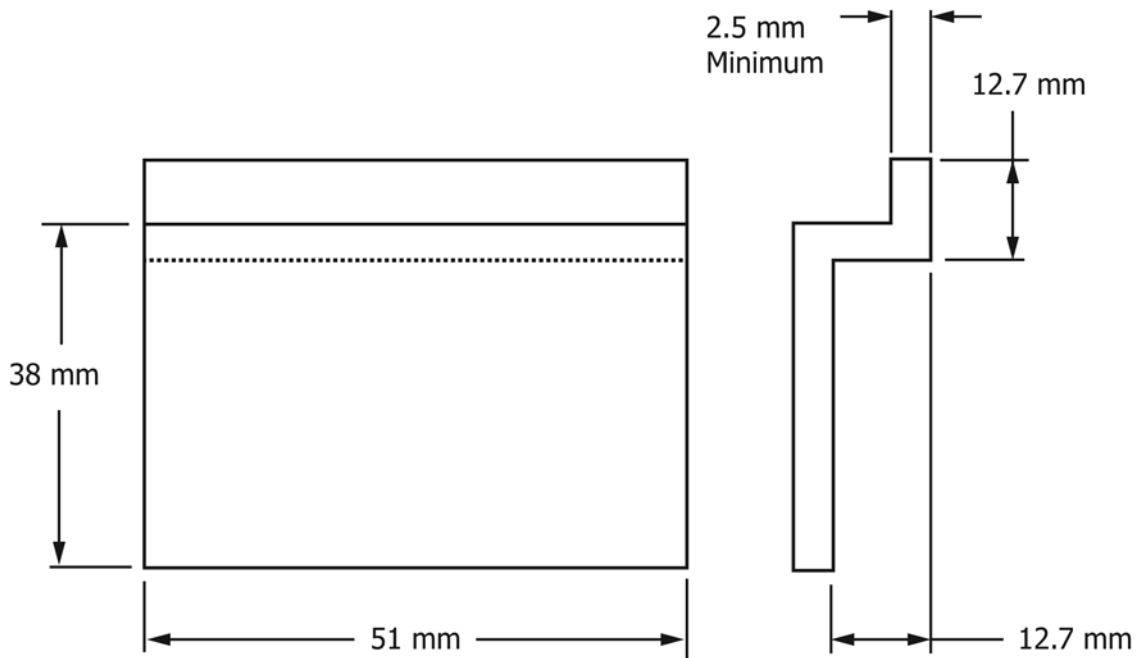

FIG. A5.1 Oil Pan Modifications for External Oil System—Auxiliary Oil System Suction Port Location (see 6.3.9.1)



NOTE 1—Bend radii to be compatible with material thickness.

FIG. A5.2 Oil Pan Modifications for External Oil System—Suction Port Baffle Design

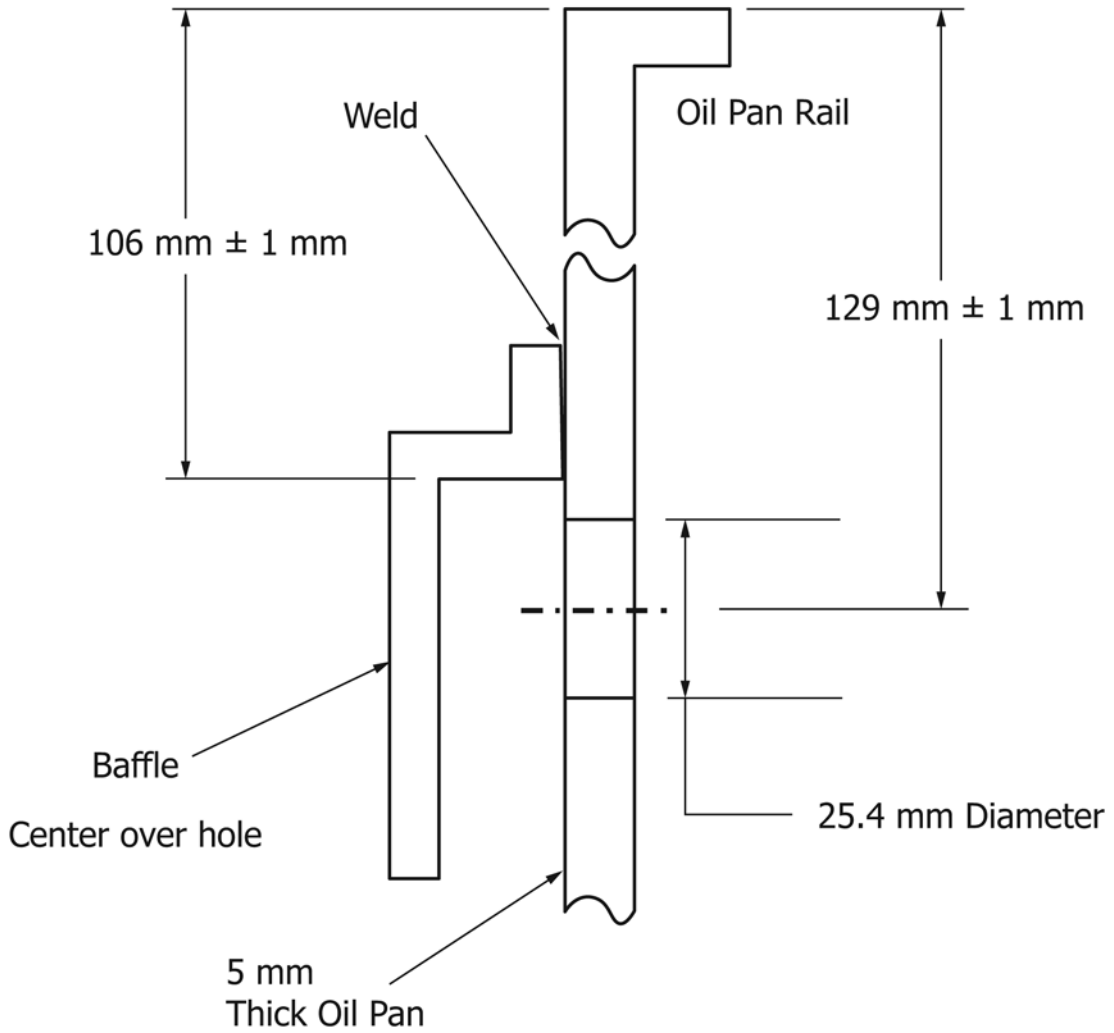

FIG. A5.3 Oil Pan Modifications for External Oil System—Baffle Placement on Oil Pan

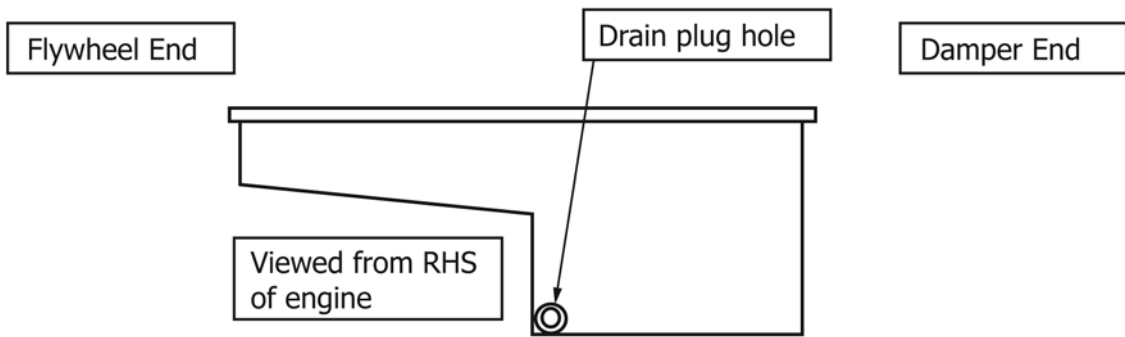

FIG. A5.4 Oil Pan Modifications for External Oil System—Auxiliary Oil System Return Port Location

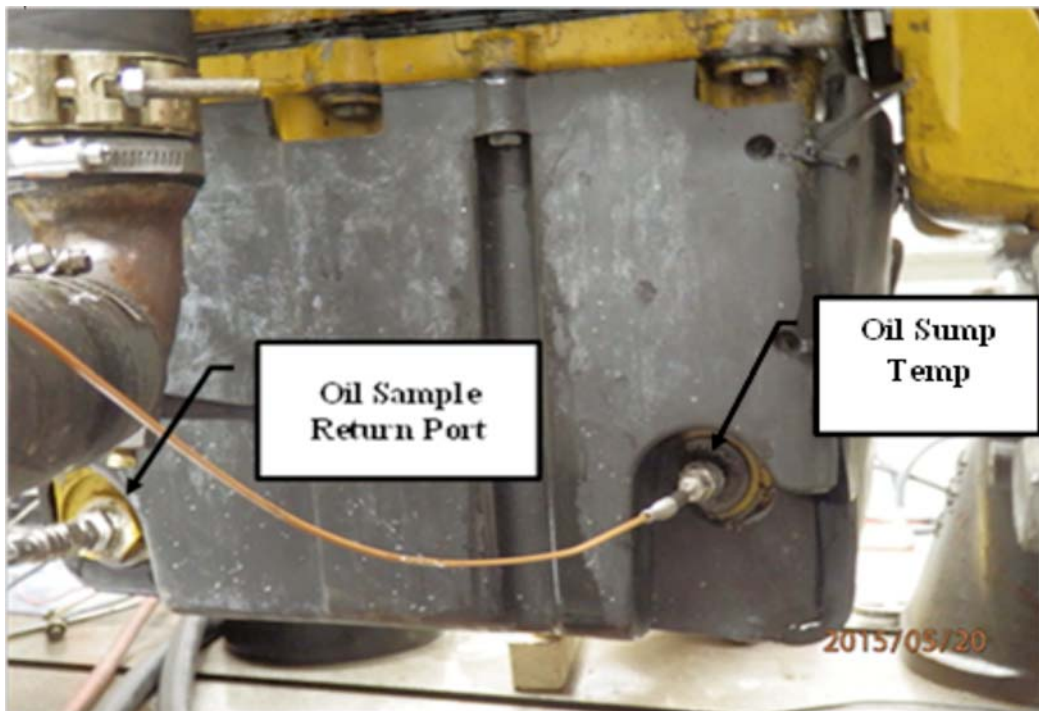

FIG. A5.5 Oil Sample Return and Oil Sump Temperature Location

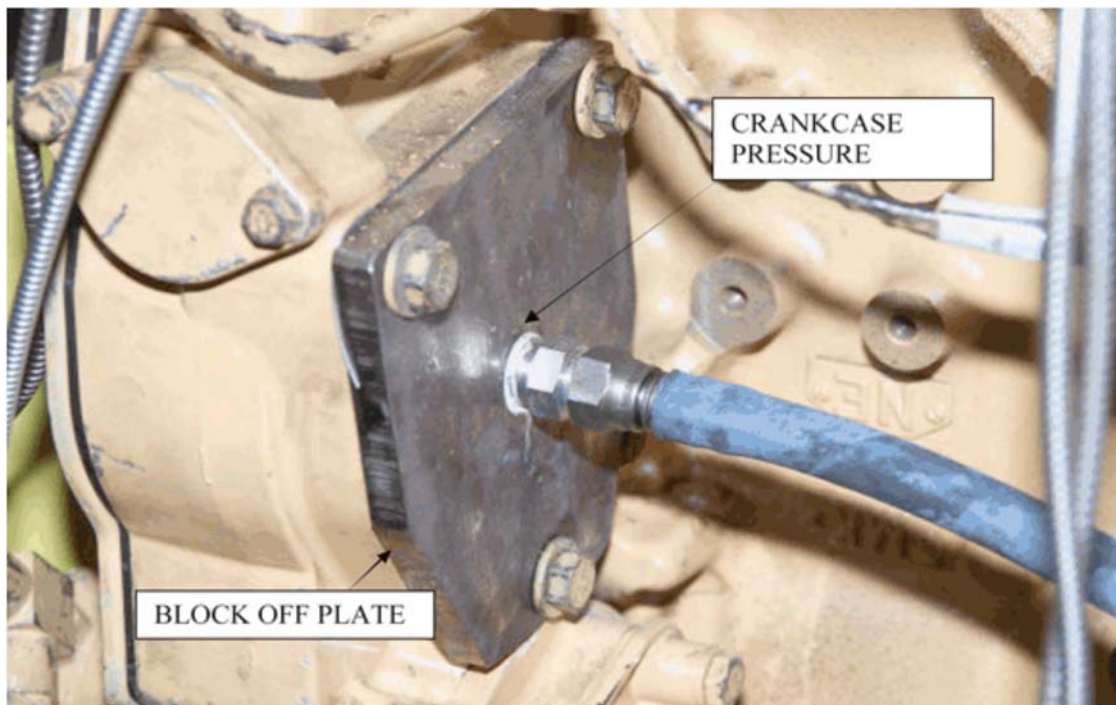

FIG. A5.6 Connection for Compressor Block-off Plate and Crankcase Pressure Balance



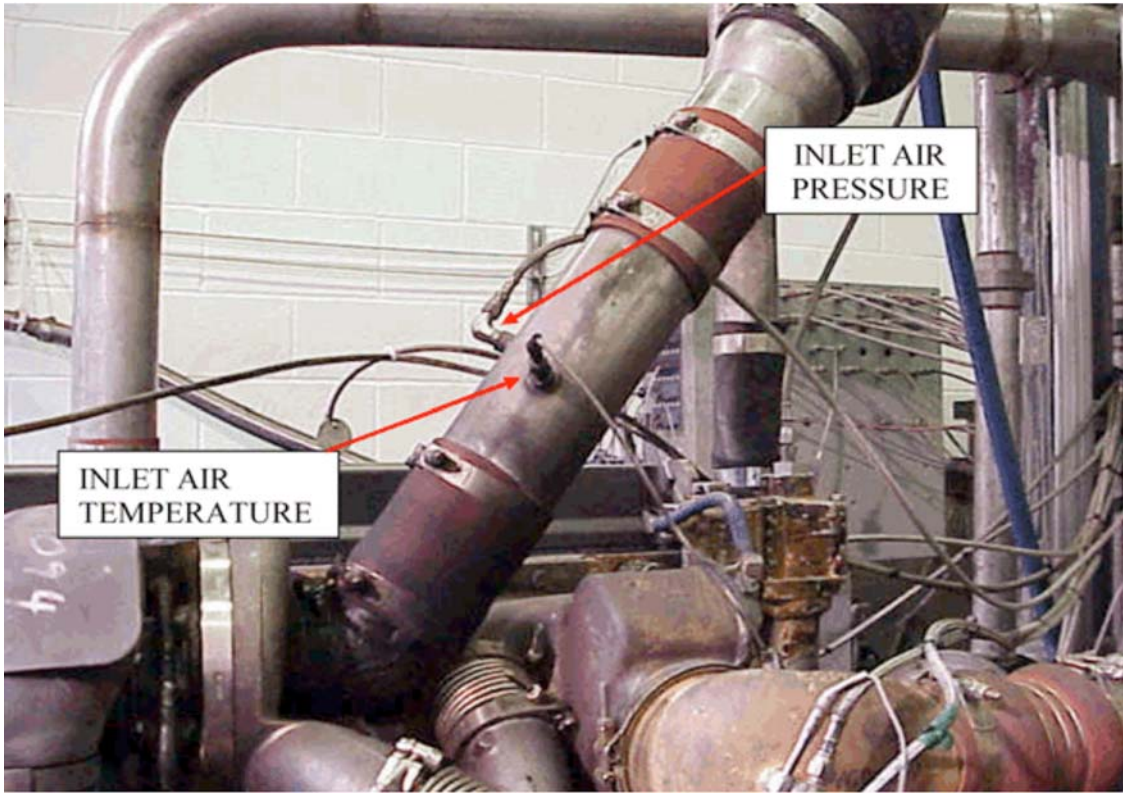

FIG. A5.7 Inlet Tube

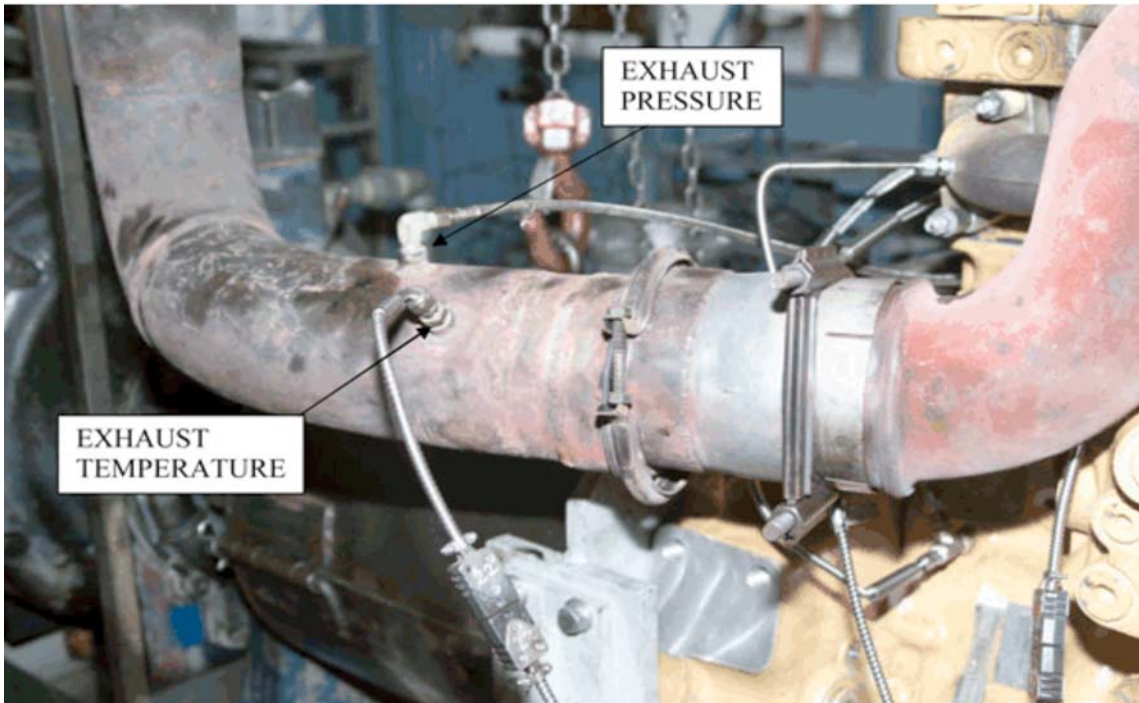

FIG. A5.8 Exhaust Tube



FIG. A5.9 Port for Inlet Pressure of Oil Filter



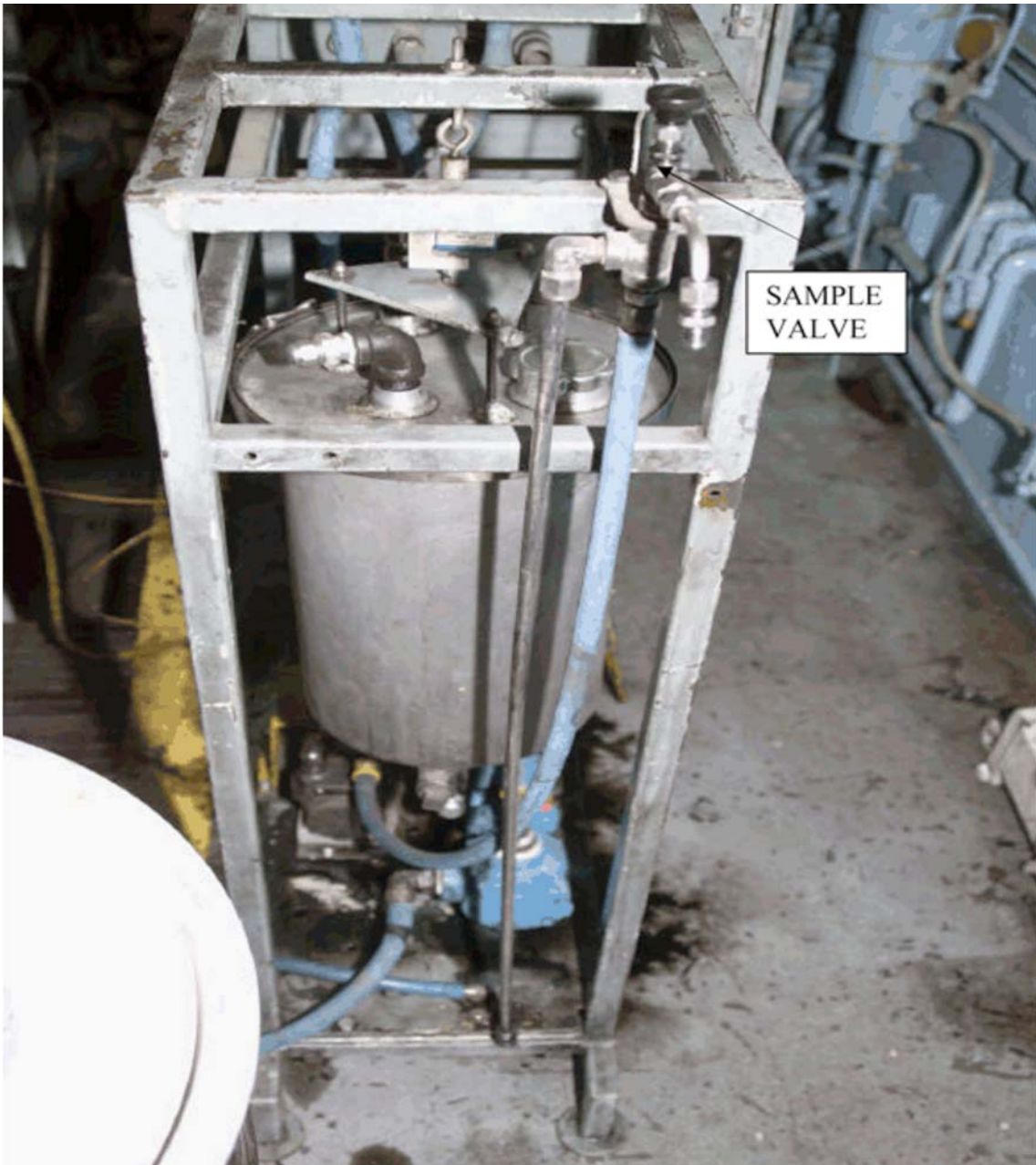

FIG. A5.10 Oil Mass Cart

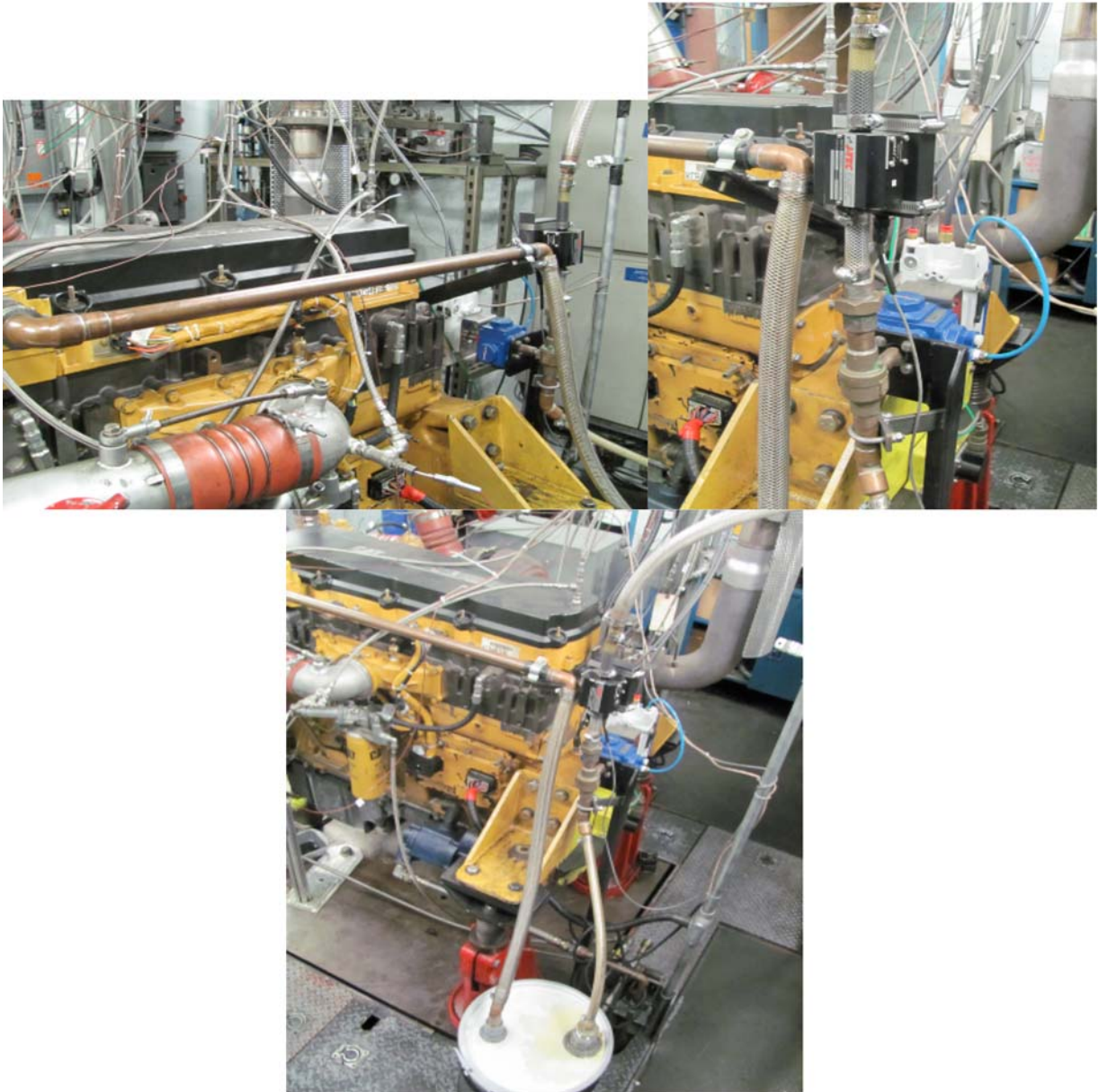

FIG. A5.11 Control System for Blowby Flow and Crankcase Pressure



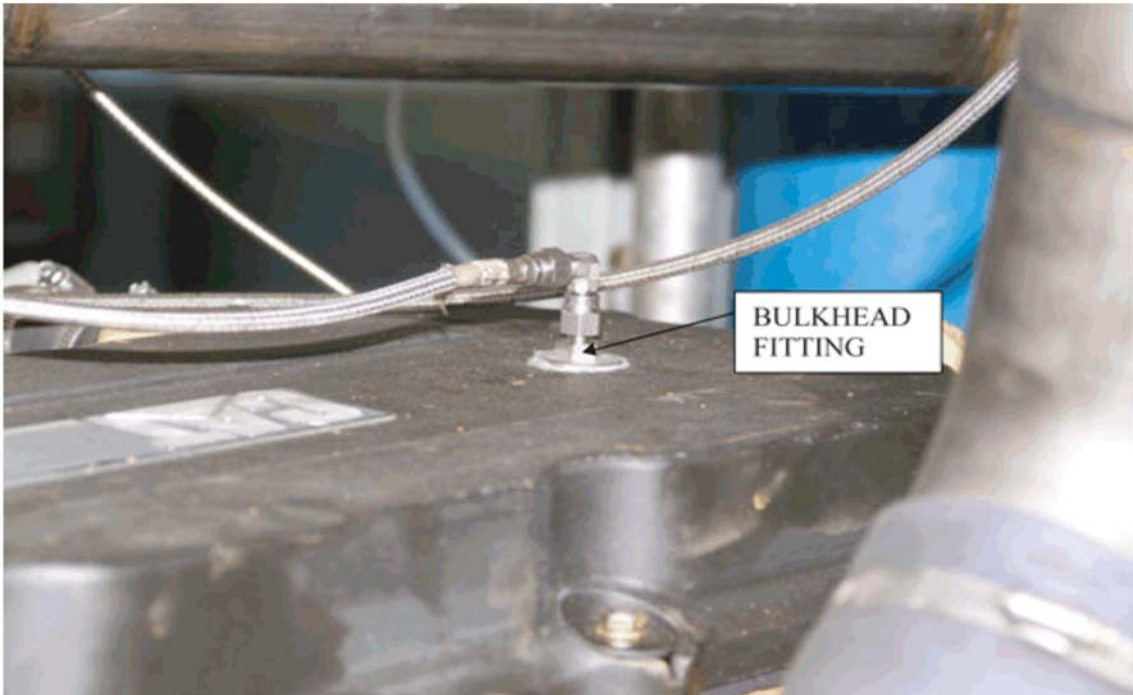

FIG. A5.12 Connection for Crankcase Pressure



FIG. A5.13 Coolant-Outlet Temperature

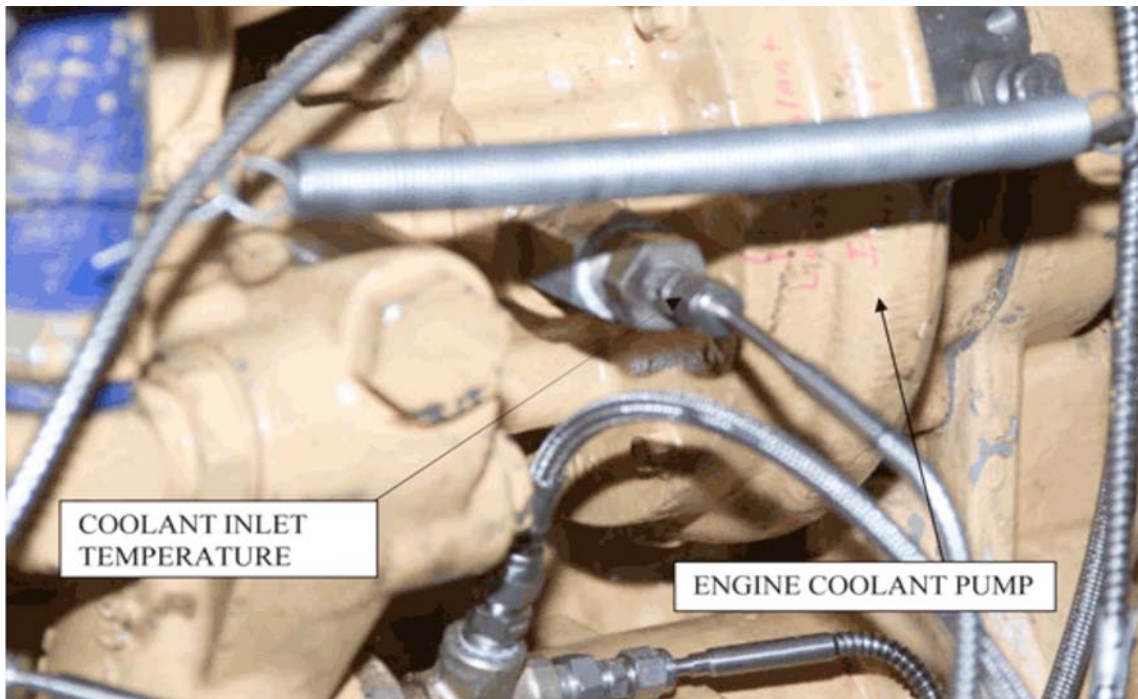

FIG. A5.14 Coolant to Engine

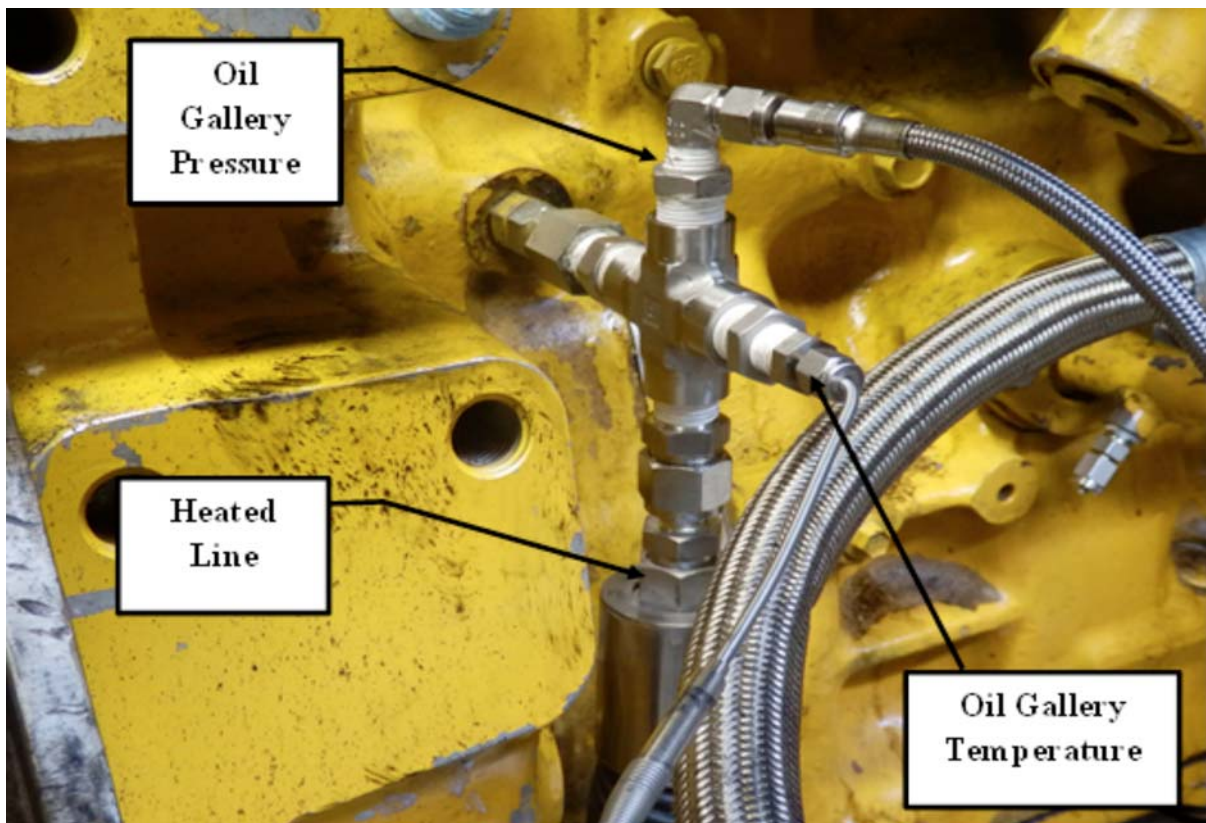

FIG. A5.15 Oil-Gallery Sample Fitting with Heated Line, Pressure and Temperature Measurements



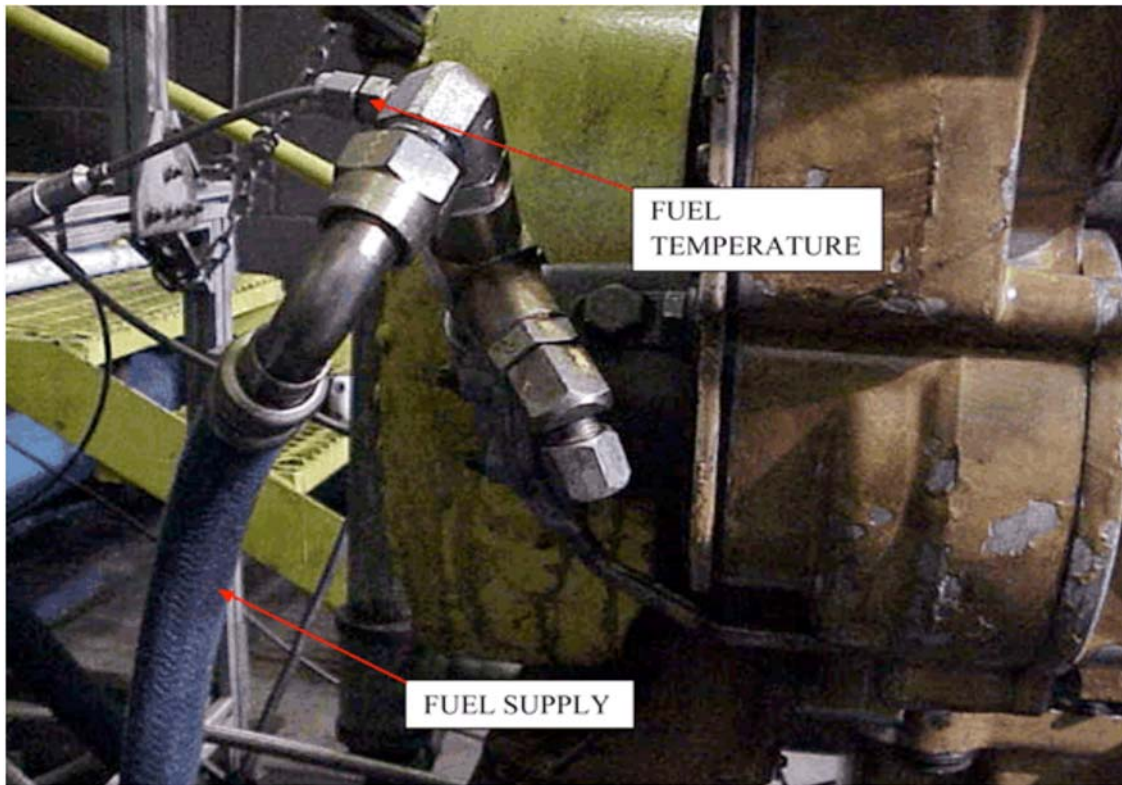

FIG. A5.16 Measurement of Fuel-to-Engine Temperature

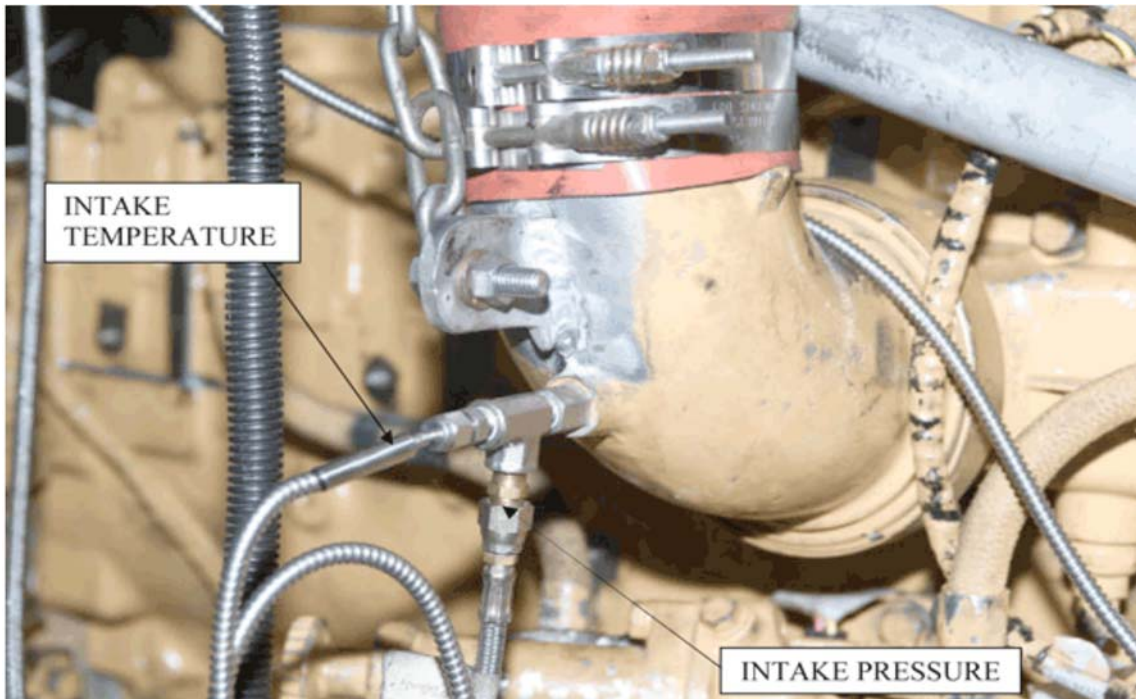

FIG. A5.17 Measurement of Intake-Manifold Pressure and Temperature

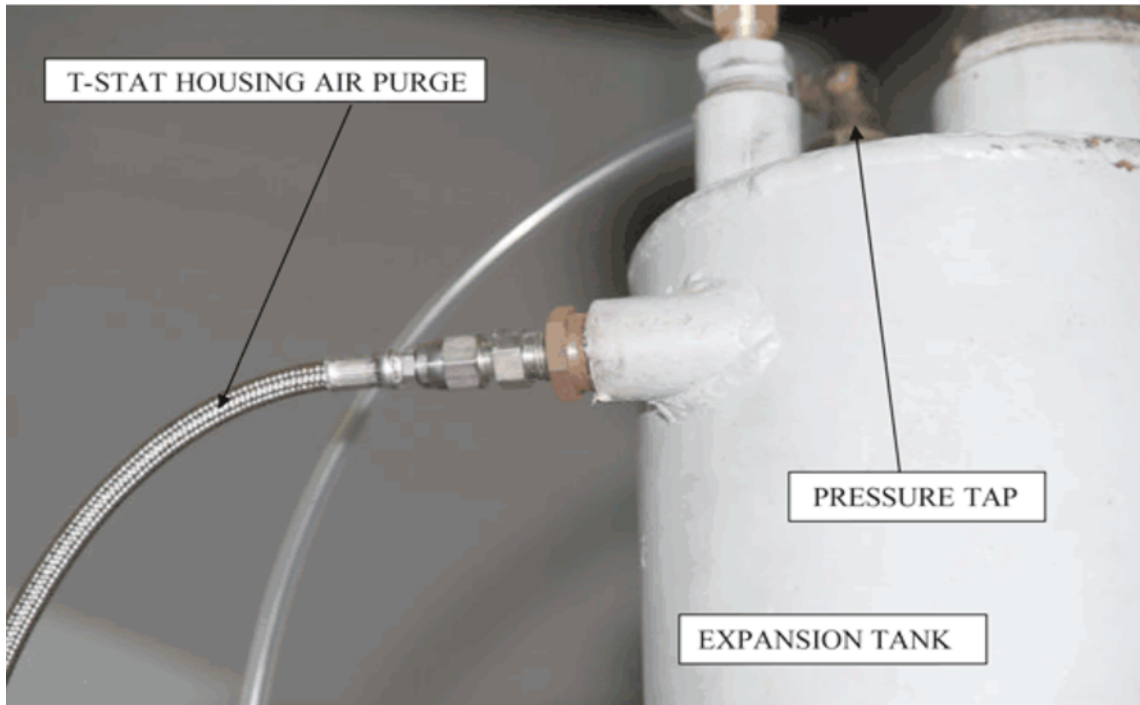

FIG. A5.18 Measurement of Cooling-System Pressure



FIG. A5.19 Right-Hand Side of Installed Engine





FIG. A5.20 Left-Hand Side of Installed Engine

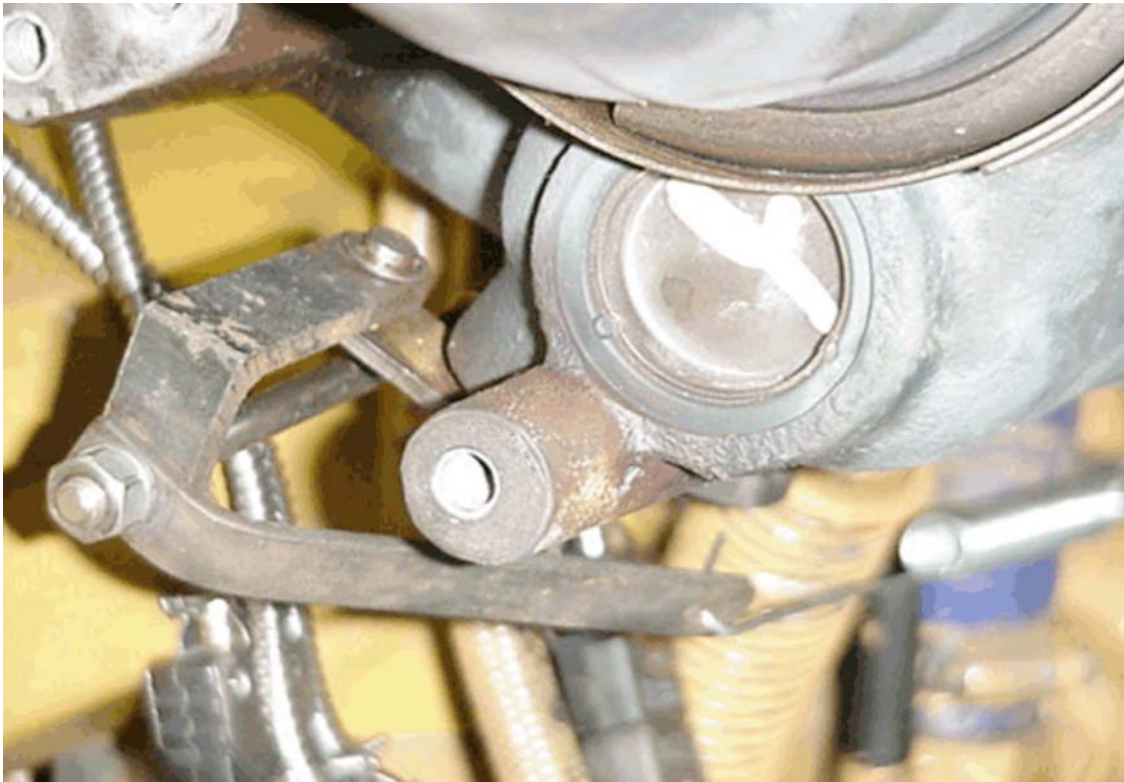

FIG. A5.21 Turbocharger Wastegate Control



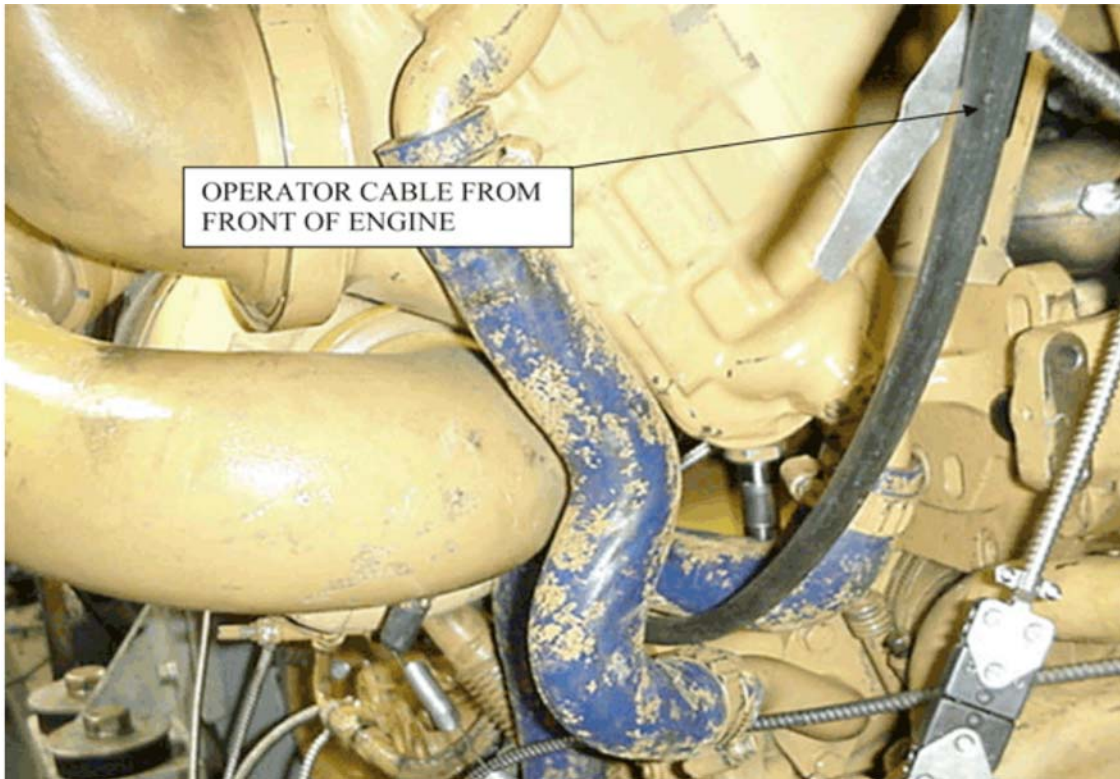

FIG. A5.22 Turbocharger Wastegate Control Cable

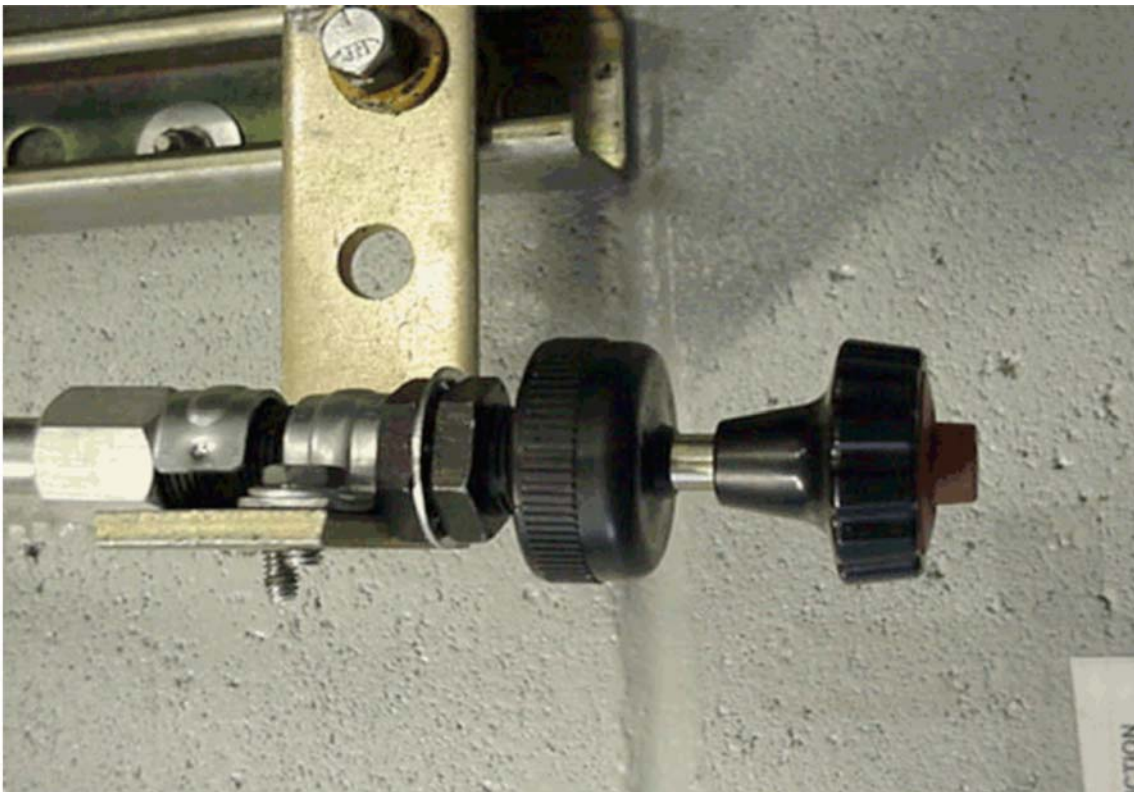

FIG. A5.23 Manual Adjuster for Turbocharger Wastegate Control





FIG. A5.24 Location for Pressurized Oil Fill

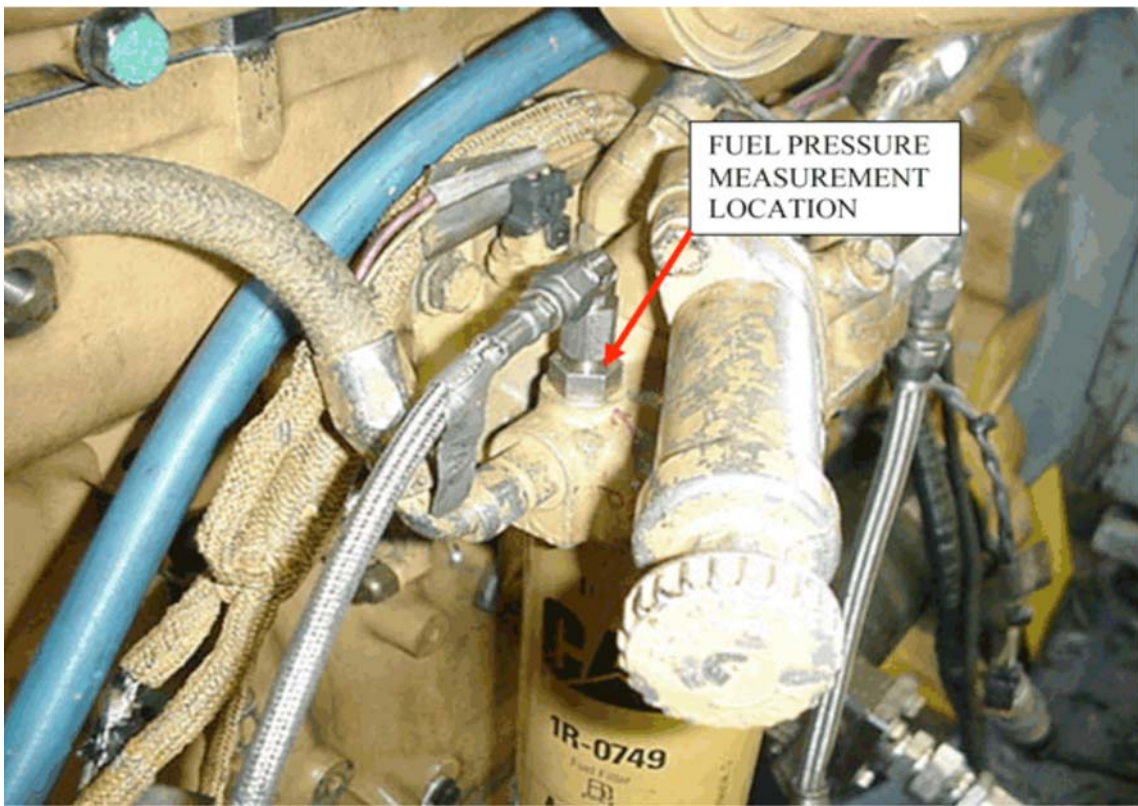

FIG. A5.25 Location of Fuel-Pressure Measurement

A6. EXTERNAL OIL SYSTEM

A6.1 The external oil system is shown in Fig. A6.1. The external oil system is used during new or rebuilt engine full-load break-ins only.

Hoses:

Supply - Nominal 12 mm; max length 2.7 m

Return - Nominal 10 mm; max length 2.7 m

Vent - 12 mm minimum

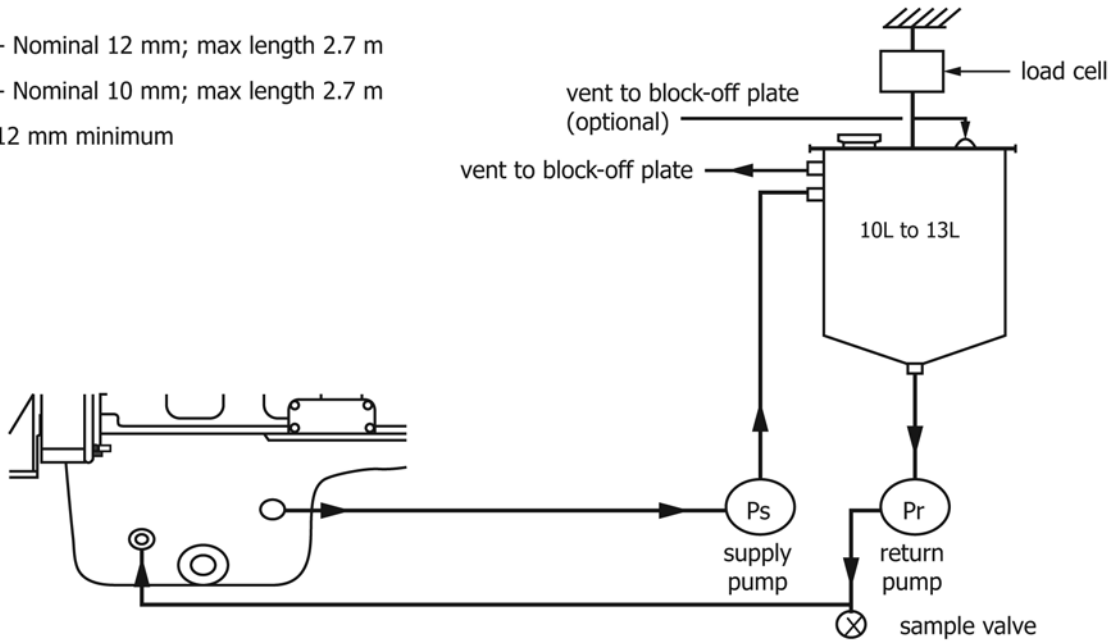

FIG. A6.1 External Oil System



## A7. AERATION MEASUREMENT SYSTEM

A7.1 The general layout is shown in Figs. A7.1 and A7.2.

A7.2 *Aeration System Piping*—The following sections are numbered in the order of flow:

A7.2.1 *Oil Gallery Outlet*—Pull the system inlet oil from the right-hand, upper-rear gallery port using a NPT  $\frac{3}{8}$  in. straight-thread-male fitting. Connect the latter to a NPT  $\frac{3}{8}$  in. cross fitting by a NPT  $\frac{3}{8}$  in. male-to-male nipple. This cross fitting is used for gallery pressure, temperature, and the aeration oil sample flow.

A7.2.2 *Heated Line*—Connect a 1.5 m by  $\frac{1}{2}$  in. internal diameter (ID) heated line to the lower port of the cross fitting. See A7.2.2.1. (This is a critical part—see A7.3.1.) Bend this line to accommodate the orientations and locations shown in Fig. A5.15. See A7.2.2.2.

A7.2.2.1 Fittings needed to convert between pipe sizing or thread types are not defined. Select these fittings to maintain a minimum amount of additional length and as constant an internal diameter as possible.

A7.2.2.2 When bending the heated line, ensure it does not bend or kink as this can cause erroneous results. Use the manufacturer’s recommended bend radius and methods.

A7.2.3 *Pressure Regulator*—Mount a pressure regulator to the heated line and orient it for vertical flow. This is a critical part described in A7.3.2.

A7.2.4 *FDM Inlet Line*—Run a 9.2 mm ID nominal tubing line not to exceed 305 mm. in length from the outlet of the regulator. See A7.2.2.1.

A7.2.5 *4-way Coupling*—Place a  $\frac{1}{2}$  in. NPT cross fitting with the pressure line facing upwards and thermocouple fitting downwards. See A7.2.2.1.

A7.2.6 *Flow and Density Meter (FDM)*—Orient a Micro Motion Elite FDM (this is a critical part as described in A7.3.3) and a Micro Motion Elite Transmitter with the FDM inlet centerline horizontal and the unit plane vertical. See A7.2.2.1.

A7.2.7 *Mount*—Use a height-adjustable mount for mounting the FDM (23 cm  $\pm$  3 cm above oil pan gasket to FDM centerline).

A7.2.8 *4-way Coupling*—Place a  $\frac{1}{2}$  in. NPT cross fitting with the pressure line facing upwards and thermocouple fitting downwards. See A7.2.2.1.



FIG. A7.1 General Layout of the Engine and Aeration System

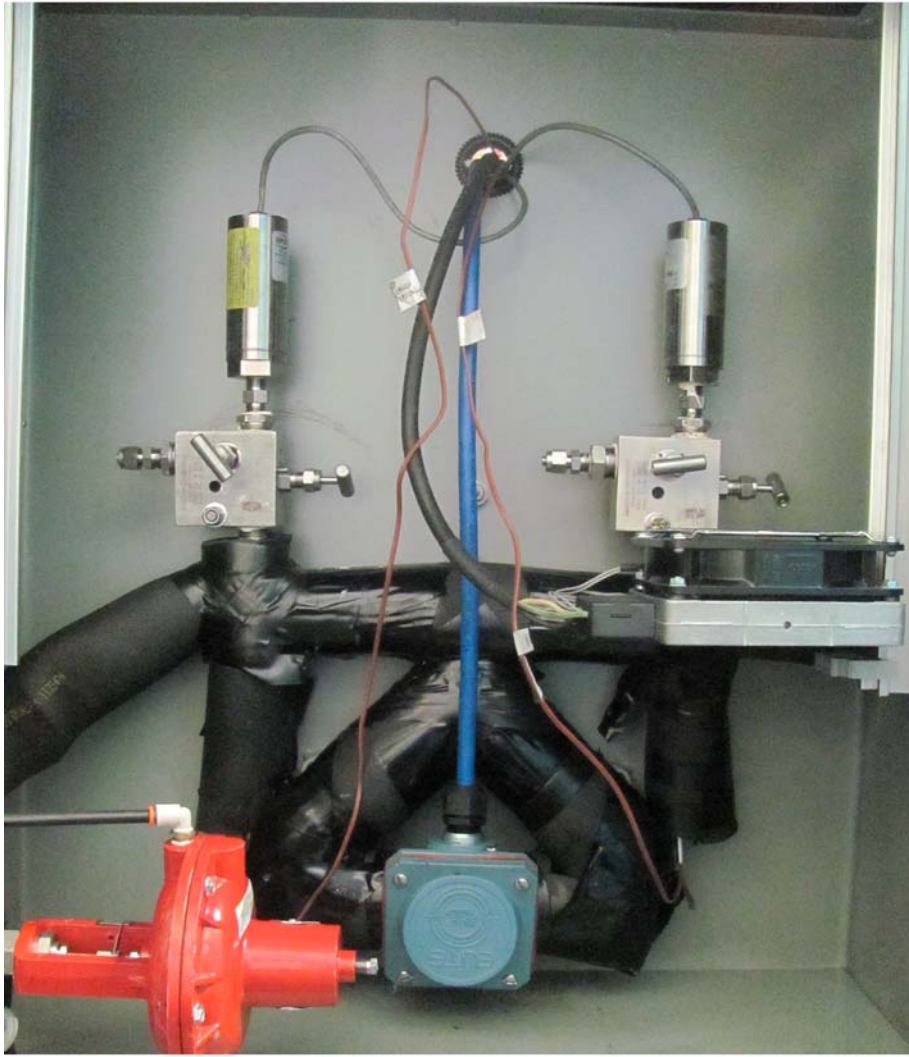

FIG. A7.2 Aeration Measurement System and Enclosure

A7.2.9 *FDM Outlet Line*—Run a 121.9 cm by 7 mm nominal tubing line from the temperature/pressure coupling to the pump. See A7.2.2.1.

A7.2.10 *Pump*—Mount the pump to the motor with the inlet centerline horizontal. This is a critical part as described in A7.3.4.

A7.2.11 *Sump Return*—Run a 121.9 cm by 7 mm ID nominal tubing line from the pump to the right-side, rear drain plug.

A7.3 *Aeration System Critical Parts List and Sourcing:*

A7.3.1 *Heated Line*—1.5 m by ½ in. Unique Heated Products insulated and heated stainless steel line, model number SII-B-8-060-S-E8-PPO-A-AK-D72-000.<sup>20,7</sup>

<sup>20</sup> The sole source of supply of the apparatus known to the Committee at this time is Unique Heated Products Inc., 51925 Gratiot Avenue, Chesterfield, MI 48051. www.heatedproducts.com.

A7.3.2 *Regulator*—2way Badger Meter Research Control Valve (¼ in., H Trim, Air-to-Open), model number 1001GCN36SVOHLN36.<sup>21,7</sup>

A7.3.3 *Flow and Density Meter (FDM)*—Micro Motion Elite, Model CMF 025, stainless steel.<sup>8,7</sup>

A7.3.4 *Variable Speed Pump*—Micro Motion Pump model number S-74014-40, gear pump system 115V 14.700 LBS 38.<sup>8,7</sup>

<sup>21</sup> The sole source of supply of the apparatus known to the Committee at this time is Badger Meter Inc. www.badgermeter.com.

## A8. SPECIFIED UNITS AND FORMATS

### A8.1 Specified Units:

A8.1.1 *Test Report*—Record operational quantities according to **Table A8.1**. Report test results in the units and with the significant digits shown in **Table A8.2**. Round test results in compliance with Practice **E29**.

A8.1.2 *Measurements and Conversions*—Except for the exceptions noted in **1.2.1**, all quantities have been specified in SI units. The intent of this test method is to measure all quantities directly in SI units. If quantities are measured in inch-pound units, then the laboratory shall show to the TMC that the measurements are within the tolerances after conversion to SI units.

A8.1.2.1 Significant error may occur due to rounding or tolerance stacking, or both, when converting from inch-pound units to SI units.

**TABLE A8.1 Units and Precision**

Quantity	Record Data to Nearest
Speed	1 r/min
Fuel Flow	1 g/min
Coolant In Temperature	0.1 °C
Coolant Out Temperature	0.1 °C
Fuel In Temperature	0.1 °C
Oil Gallery Temperature	0.1 °C
Intake-air Temperature	0.1 °C
Exhaust (Tailpipe) Temperature	1 °C
Intake-manifold Pressure	0.1 kPa
Crankcase Pressure	0.01 kPa
Exhaust Pressure	0.1 kPa

**TABLE A8.2 Units and Precision**

Quantity, units	Round Off to Nearest
Oil Aeration, %	0.01 %

A8.2 *Specification Format*—Specifications are listed in three formats: (1) target; (2) target and range; and (3) range with no target.

A8.2.1 *Target*—A target specification has no tolerance. Therefore, the only acceptable value is the target. A representative specification format is xx.xx (target). For example, the oil pan charge is listed as 30.8 kg.

A8.2.1.1 Do not intentionally calibrate or control a parameter with a target at a level other than the target.

A8.2.2 *Target and Range*—A target and a range specification implies that the correct value is the target and the range is intended as a guide for maximum acceptable variation about the mean. A representative specification format is xx.xx ± x.xx (target ± range). For example, the engine speed is 1800 r/min ± 5 r/min.

NOTE A8.1—The mean of a random sample should be equivalent to the target. Operation within the range does not imply that the quantity will not bias the final test results.

A8.2.3 *Range with No Target*—A range with no target specification is used when: (1) the quantity is not critical and control within the range is sufficient; or (2) the measurement technique is not precise, or both. A representative format is xx.xx to xx.xx (range<sub>low</sub> to range<sub>high</sub>). For example, the system coolant pressure is 99 kPa to 107 kPa.

## A9. ASTM TMC: CALIBRATION PROCEDURES

A9.1 *Reference Oils*—These oils are formulated or selected to represent specific chemical, or performance levels, or both. They are usually supplied directly to a testing laboratory under code numbers to ensure that the laboratory is not influenced by prior knowledge of acceptable results in assessing test results. The TMC determines the specific reference oil the laboratory shall test.

A9.1.1 *Reporting Reference-Oil Data*—Test laboratories that receive reference oils for stand calibration shall submit data to the TMC on every sample of reference oil they receive. If a shipment contains any missing or damaged samples, the laboratory shall notify the TMC immediately.

### A9.2 Calibration Testing:

A9.2.1 Full-scale calibration testing shall be conducted at regular intervals. These full-scale tests are conducted using coded reference oils supplied by the TMC. It is a laboratory's responsibility to keep the on-site reference-oil inventory at or above the minimum level specified by the TMC test engineers.

A9.2.2 *Test Stands Used for Non-Standard Tests*—If a non-standard test is conducted on a previously calibrated test stand, the laboratory shall conduct a reference-oil test on that stand to demonstrate that it continues to be calibrated, prior to running standard tests.

A9.3 *Reference-Oil Storage*—Store under cover in locations where the ambient temperature is between −10 °C and +50 °C.

A9.4 *Analysis of Reference Oils*—Unless specifically authorized by the TMC, do not analyze TMC reference oils, either physically or chemically. Do not resell ASTM reference oils or supply them to other laboratories without the approval of the TMC. The reference oils are supplied only for the intended purpose of obtaining calibration under the ASTM Test Monitoring System. Any unauthorized use is strictly forbidden. The testing laboratory tacitly agrees to use the TMC reference oils exclusively in accordance with the TMC's published Policies for Use and Analysis of ASTM Reference Oils, and to run and



report the reference-oil test results according to TMC guidelines. Additional policies for the use and analysis of ASTM Reference oils are available from the TMC.

*A9.5 Conducting a Reference-Oil Test*—When laboratory personnel are ready to run a reference calibration test, they shall request an oil code via the TMC website.

*A9.6 Reporting Reference-Oil Test Results*—Upon completion of the reference-oil test, the test laboratory transmits the data electronically to the TMC, as described in Section 12. The

TMC reviews the data and contacts the laboratory engineer to report the laboratory's calibration status. All reference-oil test results, whether aborted, invalidated, or successfully completed, shall be reported to the TMC.

A9.6.1 All deviations from the specified test method shall be reported.

## **A10. ASTM TEST MONITORING CENTER: MAINTENANCE ACTIVITIES**

*A10.1 Special Reference-Oil Tests*—To ensure continuous severity and precision monitoring, calibration tests are conducted periodically throughout the year. Occasionally, the majority or even all of the industry's test stands will conduct calibration tests at roughly the same time. This could result in an unacceptably large time frame when very few calibration tests are conducted. The TMC can shorten or extend calibration periods as needed to provide a consistent flow of reference-oil test data. Adjustments to calibration periods are made such that laboratories incur no net loss or gain in calibration status.

*A10.2 Special Use of the Reference-Oil Calibration System*—The surveillance panel has the option to use the reference-oil system to evaluate changes that have potential impact on test severity and precision. This option is only taken when a program of donated tests is not feasible. The surveillance panel and the TMC shall develop a detailed plan for the test program. This plan requires all reference-oil tests in the program to be completed as close to the same time as possible, so that no laboratory/stand calibration status is left pending for an excessive length of time. In order to maintain the integrity of the reference-oil monitoring system, each reference-oil test is conducted so as to be interpretable for stand calibration. To facilitate the required test scheduling, the surveillance panel may direct the TMC to lengthen and shorten reference-oil calibration periods within laboratories such that the laboratories incur no net loss or gain in calibration status. To ensure accurate stand, or laboratory, or both severity assessments, conduct non-reference-oil tests the same as reference-oil tests.

*A10.3 Donated Reference-Oil Test Programs*—The surveillance panel is charged with maintaining effective reference-oil test severity and precision monitoring. During times of new parts introductions, new or re-blended reference-oil additions, and procedural revisions, it may be necessary to evaluate the possible effects on severity and precision levels. The surveillance panel may choose to conduct a program of donated reference-oil tests in those laboratories participating in the monitoring system, in order to quantify the effect of a particular change on severity and precision. Typically, the surveillance panel requests its panel members to volunteer enough

reference-oil test results to create a robust data set. Broad laboratory participation is needed to provide a representative sampling of the industry. To ensure the quality of the data obtained, donated tests are conducted on calibrated test stands. The surveillance panel shall arrange an appropriate number of donated tests and ensure completion of the test program in a timely manner.

*A10.4 Intervals Between Reference-Oil Tests*—Under special circumstances, such as extended downtime caused by industry-wide parts or fuel shortages, the TMC may extend the intervals between reference-oil tests.

*A10.5 Introducing New Reference Oils*—Reference oils produce various results. When new reference oils are selected, participating laboratories will be requested to conduct their share of tests to enable the TMC to recommend industry test targets. ASTM surveillance panels require a minimum number of tests to establish the industry test targets for new reference oils.

*A10.6 TMC Information Letters*—Occasionally it is necessary to revise the test method, and notify the test laboratories of the change, prior to consideration of the revision by Subcommittee D02.B0. In such a case, the TMC issues an Information Letter. Information Letters are balloted semi-annually by Subcommittee D02.B0, and subsequently by D02. By this means, the Society due process procedures are applied to these Information Letters.

*A10.6.1 Issuing Authority*—The authority to issue an Information Letter differs according to its nature. In the case of an Information Letter concerning a part number change which does not affect test results, the TMC is authorized to issue such a letter. Long-term studies by the surveillance panel to improve the test procedure through improved operation and hardware control may result in the issuance of an Information Letter. If obvious procedural items affecting test results need immediate attention, the test sponsor and the TMC issue an Information Letter and present the background and data supporting that action to the surveillance panel for approval prior to the semiannual Subcommittee D02.B0 meeting.



A10.7 *TMC Memoranda*—In addition to the Information Letters, supplementary memoranda are issued. These are developed by the TMC and distributed to the appropriate surveillance panel and participating laboratories. They convey such information as batch approvals for test parts or materials,

clarification of the test procedure, notes and suggestions of the collection and analysis of special data that the TMC may request, or for any other pertinent matters having no direct effect on the test performance, results, or precision and bias.

**A11. ASTM TEST MONITORING CENTER: RELATED INFORMATION**

A11.1 *New Laboratories*—Laboratories wishing to become part of the ASTM Test Monitoring System will be requested to conduct reference-oil tests to ensure that the laboratory is using the proper testing techniques. Information concerning fees, laboratory inspection, reagents, testing practices, appropriate committee membership, and rater training can be obtained by contacting the TMC Director.

A11.2 *Information Letters: COTCO Approval*—Authority for the issuance of Information Letters was given by the committee on Technical Committee Operations in 1984, as

follows: “COTCO recognizes that D02 has a unique and complex situation. The use of Information Letters is approved providing each letter contains a disclaimer to the affect that such has not obtained ASTM consensus. These Information Letters should be moved to such consensus as rapidly as possible.”

A11.3 *Precision Data*—The TMC determines the precision of test methods by analyzing results of calibration tests conducted on reference oils. Precision data are updated regularly. Current precision data can be obtained from the TMC.

**A12. ENGINE BREAK-IN AND SILICON PASSIVATION PROCEDURE**

A12.1 *General*—The purpose of this break-in is to properly stabilize engine performance by breaking-in new engine components and to passivate any engine-build silicon and fluid remnants. Such silicon can leach into the engine oil and cause elevated aeration levels.

A12.1.1 The silicon-free oil pan and rocker cover gaskets and spacers (which are critical parts—see [Table A3.1](#)) contribute to a reduction in the time for silicon passivation, as does the use of silicon-free sealants (see [7.5](#)).

A12.2 Measure the mass fraction of silicon in the fresh oil using the ICP-AES Test Method [D5185](#).

A12.3 Install a new Caterpillar 1R-1808 oil filter.

A12.4 Charge the engine, as described in [10.2.2.1](#), with the Cat DEO-ULS 15W-40 oil or an equivalent Caterpillar certified CJ-4 10W-40 oil.

A12.5 *Engine Warmup and Break-in*—Prior to firing the engine, ensure that the oil temperature is at least 15 °C. The oil gallery startup pressure shall be at least 350 kPa. Perform a timing calibration for the engine control software and timing sensor components as specified in Caterpillar Service Manual Form SEN R 9700 and Caterpillar Parts Manual C-13 On-Highway Engine, Media number SEBP3735.<sup>16</sup> If the coolant temperature is less than 18 °C, the engine will operate under cold mode thereby preventing the timing calibration procedure from being performed. When this happens, start the engine and allow it to idle until the speed drops from 1000 r/min to 600 r/min, signaling that the coolant temperature has exceeded 18 °C. After the timing calibration is completed, continue break-in conditions as shown in [Table A12.1](#). Turn on the external oil weigh system pumps at the beginning of stage 2.

A12.5.1 At the completion of the initial 60 min break-in, shut the engine down as follows:

**TABLE A12.1 60 min Break-in Conditions**

Quantity, units	Stage				
	1	2	3	4	5
Stage Length, min	5	5	10	20	20
Speed, r/min	1100	1200	1600	1800	1800 ± 5
Fuel Flow Rate, g/min	Record	Record	Record	Record	1200 ± 6
Torque, N·m	0	480	1000	1160	Record
Coolant Out Temperature, <sup>A</sup> °C	88	88	88	88	88 ± 2
Oil Gallery Temperature, <sup>A</sup> °C	Record	Record	Record	Record	98 ± 2
Intake-manifold Temperature, <sup>A</sup> °C	40	40	40	40	40 ± 2

<sup>A</sup> This is the control set-point. It can require up to 30 min of operation to achieve.

TABLE A12.2 Warmup Conditions

Quantity, units	Stage				
	1	2	3	4	5
Stage Length, min	2.5	2.5	5	10	10
Speed, r/min	1100	1200	1600	1800	1800
Fuel Flow Rate, g/min	Record	Record	Record	Record	1200
Torque, N·m	0	480	1000	1160	Record
Coolant Out Temperature, <sup>A</sup> °C	88	88	88	88	88
Oil-Gallery Temperature, <sup>A</sup> °C	Record	Record	Record	Record	98 ± 2
Intake-Manifold Temperature, <sup>A</sup> °C	40	40	40	40	40

<sup>A</sup> This is the control set-point. It can require up to 30 min of operation to achieve.

A12.5.2 Ramp in 30 s from test conditions to stage 2 of the warmup conditions (Table A12.2), running for 5 min at stage 2, ramping in 30 s to stage 1, running for 5 min at stage 1, and then stopping the engine.

NOTE A12.1—This shutdown differs from that described in 10.3.1.

A12.6 Valve Lash Adjustment—Allow the engine to cool for a minimum of 4 h and then perform the valve lash adjustment as described in Caterpillar Service Manual Form SEN R 9700 and Caterpillar Parts Manual C-13 On-Highway Engine, Media number SEBP3735.<sup>16</sup>

A12.7 Monitoring the Amount of Silicon in the Engine:

A12.7.1 Engine Warmup—Start the engine and run for 30 min under the warmup conditions described in Table A12.2.

NOTE A12.2—These warmup conditions are the same as those described in 10.6 of Test Method D7549. They differ from those described in 10.2.3 of this test method.

A12.7.2 Engine Running Hours 0 to 25—After the end of the 30 min warmup, proceed directly, without shutting down the engine, to the test conditions described in Table A12.3.

NOTE A12.3—These test conditions are the same as those described in

10.6 of Test Method D7549. They differ from those described in 10.6.1 of this test method.

A12.7.2.1 Take oil samples at 1 h and 25 h and determine the mass fraction of silicon in the oil as described in A12.2.

After 25 h:

A12.7.3 Carry out the following steps:

A12.7.3.1 Shut the engine down as described in A12.5.2.

A12.7.3.2 Drain the oil from the engine, the oil cooler, and the oil weigh system. Remove the oil filter.

A12.7.3.3 Install a new Caterpillar 1R-1808 oil filter and charge the engine, as described in 10.2.2.1, with the Cat DEO-ULS 15W-40 oil or an equivalent Caterpillar certified CJ-4 10W-40 oil.

A12.7.3.4 Start the engine, run for 30 min under the warmup conditions described in Table A12.2.

A12.7.4 Engine Running Hours 25 to 50—Proceed directly, without stopping the engine, to the Table A12.3 test conditions.

A12.7.4.1 Take oil samples at 30 h, 40 h, and 50 h and determine the mass fraction of silicon in the oil as described in A12.2.

After 50 h:

A12.7.4.2 Shut the engine down as described in A12.5.2, drain the oil, install a new filter, charge the engine with fresh oil, and run the 30 min warm up, as described in A12.7.3.

A12.7.5 Engine Running Hours 50 to 75—Proceed directly, without stopping the engine, to the Table A12.3 test conditions.

A12.7.5.1 Take oil samples at 51 h, 60 h, 70 h, and 75 h and determine the mass fraction of silicon in the oil as described in A12.2.

After 75 h:

A12.7.5.2 Shut the engine down as described in A12.5.2, drain the oil, install a new filter, charge the engine with fresh oil, and run the 30 min warm up, as described in A12.7.3.

A12.7.6 Engine Running Hours 75 to 85:

A12.7.6.1 Proceed directly, without stopping the engine, to the Table A12.3 test conditions.

A12.7.6.2 Take an oil sample at 80 h and determine the mass fraction of as per A12.2.

After 80 h:

A12.7.6.3 Shut the engine down as described in A12.5.2, drain the oil, install a new filter, charge the engine with fresh oil, and run the 30 min warm up, as described in A12.7.3.

TABLE A12.3 Test Conditions Used to Check Silicon Concentration

Quantity, units	Requirement
Speed, r/min	1800
Power, kW	Record
Torque (Typical), <sup>A</sup> N·m	1760
Fuel Flow Rate, g/min	1200
Intake-Manifold Temperature, °C	40
Blowby Flow Rate, L/min	Record
Coolant-Out Temperature, °C	88
Coolant-In Temperature, °C	Record
Coolant Delta Temperature, °C	Record
Fuel-In Temperature, °C	40
Oil-Gallery Temperature, °C	98
Inlet-Air Temperature, °C	25
Intake-Manifold Pressure, kPa (gauge)	275 to 285
Exhaust Temperature, °C	Record
Fuel Pressure, kPa	Record
Oil-Gallery Pressure, kPa	Record
Oil-Filter Delta Pressure, kPa	Record
Coolant-System Pressure, <sup>B</sup> kPa	99 to 107
Exhaust Restriction, kPa	6
Crankcase Pressure, kPa	Record
Inlet-Air Pressure, kPa (absolute)	93.0 ± 1.5
Intercooler Delta Pressure, kPa	15 max
Humidity, g/kg	Record

<sup>A</sup> At standard atmospheric temperature and pressure.

<sup>B</sup> As measured at the top of the expansion tank.

A12.7.7 Proceed directly, without stopping the engine, to the **Table A12.3** test conditions.

A12.7.7.1 Take an oil sample at 85 h and determine the mass fraction of silicon in the oil as **A12.2**.

**After 85 h:**

A12.7.7.2 Shut the engine down as described in **A12.5.2**, drain the oil, install a new filter, charge the engine with fresh oil, and run the 30 min warm up, as described in **A12.7.3**.

NOTE A12.4—The mechanical break-in of the engine is completed at 85 h. All further running after 85 h, whether to passivate the engine or for the 50 h test run, is under no-load conditions.

**A12.7.8 50 h Passivation Run(s):**

A12.7.8.1 *General*—After the mechanical break-in has been completed, the engine is run in segments of 50 h under no-load conditions until the silicon is deemed passivated, that is, until the decrease in the mass fraction of silicon in the oil between the 1 h and 50 h samples is  $\leq 3$  mg/kg.

A12.7.8.2 After the end of the 30 min warmup in **A12.7.7.2**, proceed directly, without shutting down the engine, to the test conditions described in **Table A12.3** *but with zero load*.

NOTE A12.5—Because the mechanical break-in is completed at 85 h (see NOTE A12.4), all further running of the engine is under no-load conditions.

A12.7.8.3 Take oil samples at 0 h, 1 h, 5 h, 25 h, and 50 h and determine the mass fraction of silicon in the oil as described in **A12.2**.

A12.7.8.4 After 50 h, shut the engine down, drain the oil, install a new filter, and charge the engine with fresh oil, as described in **A12.7.3.1** to **A12.7.3.3**.

A12.7.9 Calculate the difference in mass fraction of silicon in the oil for the samples taken at 1 h and 50 h.

A12.7.9.1 If this difference is 3 mg/kg or less, proceed to the pre test procedure described in **10.2**.

A12.7.9.2 If this difference exceeds 3 mg/kg, repeat **A12.7.8.2** to **A12.7.9** until the difference in mass fraction of silicon between the 1 h and 50 h samples is 3 mg/kg or less.

A12.7.10 Record the final engine hours.

**A13. SCHEDULE FOR TAKING OIL SAMPLES AND CARRYING OUT ANALYSES**

A13.1 At test hours 0, 1, 5, 25, and 50, remove a 125 mL purge sample, followed by a 250 mL sample for testing. Return the 125 mL purge sample to the engine through the oil-add tube.

A13.2 Carry out the following tests on all the test samples:

A13.2.1 Kinematic Viscosity at 100 °C, mm<sup>2</sup>/s (Test Method **D445**).

A13.2.2 Aluminum, chromium, copper, iron, sodium, lead, silicon, tin, mass fraction, mg/kg (ICP-AES Test Method **D5185**).

A13.3 Measure Diesel Fuel Dilution, mass fraction, % (Test Method **D3524**) on the 50 h sample.

**A14. DETERMINATION OF OPERATIONAL VALIDITY**

**A14.1 Quality Index Calculation:**

A14.1.1 Calculate Quality Index (QI) for all control quantities in accordance with the DACA II Report. Ensure missing or bad quality data are accounted for in accordance with the DACA II Report.

A14.1.2 Use the U, L, Over Range, and Under Range values shown in **Table A14.1** for the QI calculations.

A14.1.3 Round the calculated QI values to the nearest 0.001.

A14.1.4 Report the QI values on the appropriate form.

**A14.2 Averages:**

A14.2.1 Calculate averages for all control, ranged, and non-control quantities and report the values on the appropriate form.

A14.2.2 The averages for control and non-control quantities are not directly used to determine operational validity but they may be helpful when an engineering review is required (refer to A14.4).

**A14.3 Determining Operational Validity:**

A14.3.1 QI threshold values for operational validity are shown in **Table A14.1**. Specifications for all ranged quantities are shown in **Table A14.1**.

A14.3.1.1 A test with EOT QI values for all control quantities equal to or above the threshold values and with averages for all ranged quantities within specifications is operationally valid, provided that no other operational deviations exist that may cause the test to be declared invalid.

**TABLE A14.1 Quality Index and Average Calculation Values**

Control Quantity, units	Quality Index	Quality Index U & L Values		Over & Under Range Values	
		U	L	High	Low
Speed, r/min	0.000	1802.5	1797.5	1993.6	1606.4
Coolant-Out Temperature, °C	0.000	90.4	89.6	121.0	59.0
Inlet-Air Temperature, °C	0.000	26.2	23.8	118.0	-68.0
Inlet-Manifold Temperature, °C	0.000	40.5	39.5	78.7	1.3
Fuel-In Temperature, °C	0.000	40.4	39.6	71.0	9.0
Oil-Gallery Temperature, °C	0.000	90.2	89.8	105.5	74.5
Sample Measurement System Enclosure Temperature, °C	0.000	50.75	49.25	108.1	-8.1
Sample-Oil Temperature, °C	0.000	90.2	89.8	143.7	35.3
Sample-Oil Flow, L/min	0.000	1.53	1.47	3.8	-0.8
Sample-Oil Pressure, kPa (absolute)	0.000	84.35	83.65	111.1	56.9
Exhaust-Back Pressure, kPa (absolute)	0.000	104.3	103.7	127.2	80.8
Crankcase Pressure, kPa (absolute)	0.000	103.25	102.75	122.4	83.6
				Over & Under Range Values	
Ranged Quantity, units	Range			High	Low
Inlet-Air Pressure, kPa (absolute)	96.0 ± 1.5			212.2	0.0

A14.3.1.2 Conduct an engineering review (see A14.4) to determine the operational validity of a test with any control parameter QI value less than the threshold value.

A14.3.1.3 A test with a ranged parameter average value outside the specification is invalid.

#### A14.4 Engineering Review:

A14.4.1 Conduct an engineering review when a control parameter QI value is below the threshold value. A typical engineering review involves investigation of the test data to determine the cause of the below threshold QI. Other affected § may also be included in the engineering review. This can be helpful in determining if a real control problem existed and the possible extent to which it may have impacted the test. For example, a test runs with a low QI for fuel flow. An examination of the fuel flow data may show that the fuel flow data contains several over range values. At this point, an examination of exhaust temperatures may help determine whether the instrumentation problem affected real fuel flow versus affecting only the data acquisition.

A14.4.1.1 During an engineering review, give special consideration to a deviation that might affect the oil aeration measurement for either the duration of the test or during the critical measurement period of 40 h to 50 h. For example, a negative QI generated for Sample Oil Pressure for an operational deviation that occurs during the first 10 h of the test may result in declaring the test to be valid. Conversely, the same deviation that occurs from 40 h to 50 h may result in declaring the test to be invalid.

A14.4.2 For reference-oil tests, conduct the engineering review jointly with the TMC. For non-reference-oil tests, optional input is available from the TMC for the engineering review.

A14.4.3 Determine operational validity based upon the engineering review and summarize the decision in the comment section on the appropriate report form. It may be helpful to include any supporting documentation at the end of the test report. The final decision regarding operational validity rests with the laboratory.



A15. FUEL SPECIFICATION

A15.1 See Table A15.1.

TABLE A15.1 Specification for PC-10 ULSD Fuel

Quantity, units	Specification	Test Method
Mass fraction of total sulfur, mg/kg	7 to 15	D5453
Gravity, °API	34 to 37	D4052
Mass fraction of aromatic hydrocarbons, %	26 to 31.5	D5186
Volume fraction of olefin hydrocarbons, %	Report	D1319
Cetane Index	Report	D976
Cetane No.	43 to 47	D613
Copper-Strip Corrosion, classification	1 Maximum	D130
Flash Point, °C	54 Minimum	D93
Pour Point, °C	-18 Maximum	D97
Carbon Residue on 10 % Residuuum, %	0.35 Maximum	D524
	(10 % Bottoms)	
Volume of Water & Sediment, %	0.05 Maximum	D2709
Viscosity at 40 °C, mm <sup>2</sup> /s	2.0 to 2.6	D445
Total Acid Number	0.05 Maximum	D664
Strong Acid Number	0.00 Maximum	D664
Accelerated Stability	1.5 max	D2274
Mass fraction of ash, %	0.005 Maximum	D482
SLBOCLE, <sup>A</sup> g	3100 min <sup>B</sup>	D6078
90% Distillation, °C	282 to 338	D86

<sup>A</sup> Scuffing Load Ball-on-Cylinder Lubricity Evaluator.

<sup>B</sup> May be altered to be consistent with California Air Resources Board (CARB) or Specification D975 for diesel fuel.

APPENDIX

(Nonmandatory Information)

X1. TYPICAL SYSTEM CONFIGURATIONS

X1.1 See Figs. X1.1-X1.3.

See Fig. A5.7.

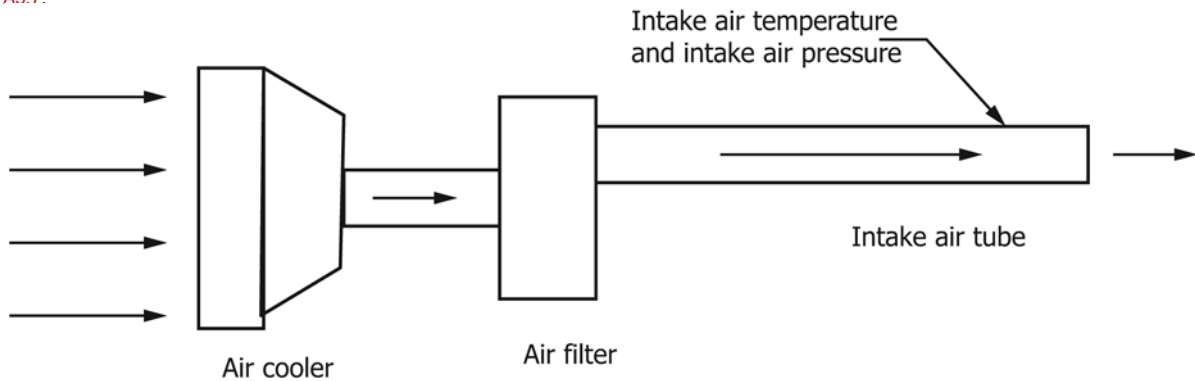

FIG. X1.1 Intake-air System (Typical)

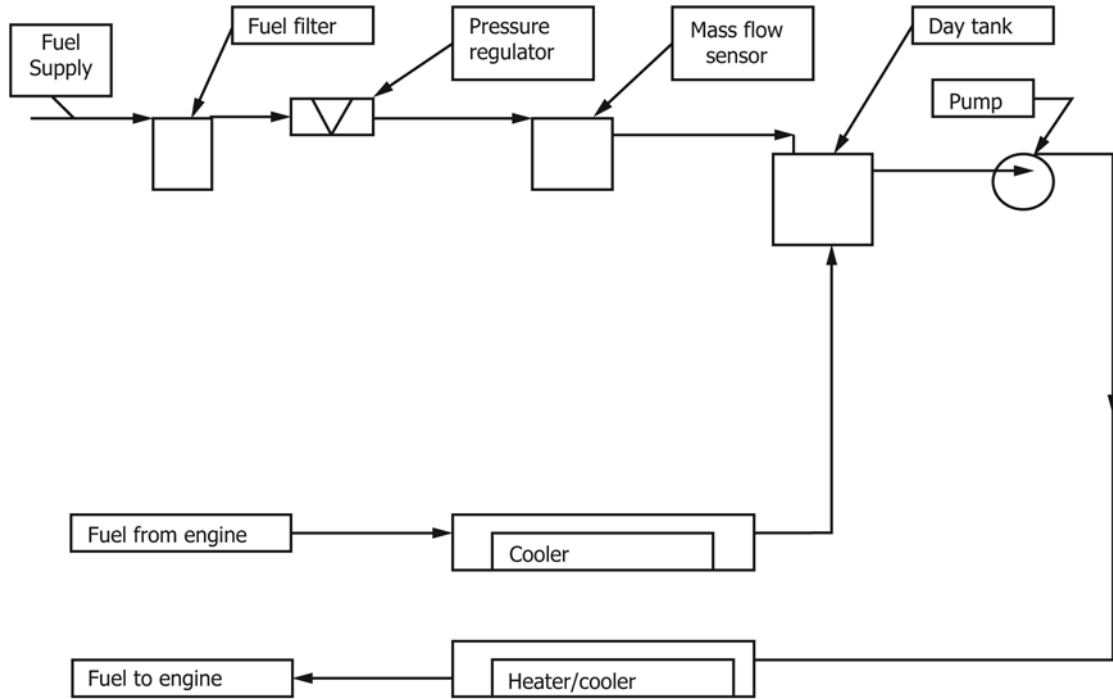

FIG. X1.2 Fuel System (Typical)

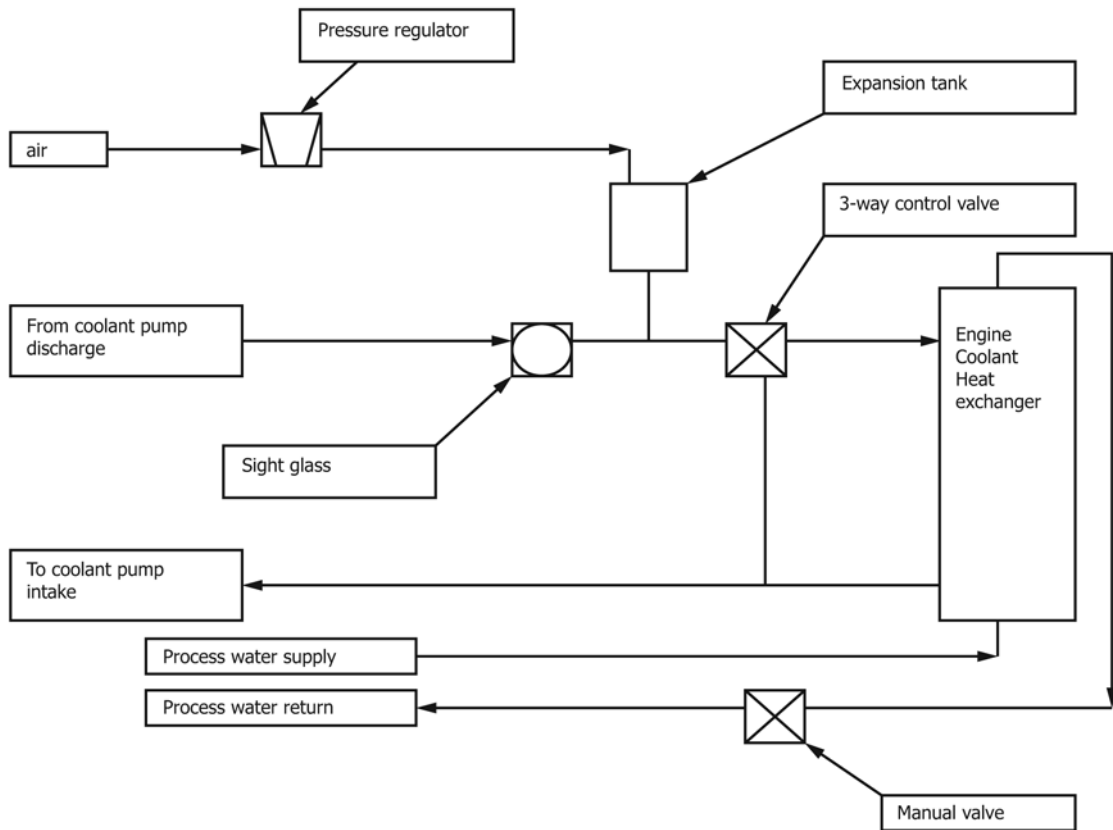

FIG. X1.3 Coolant System (Typical)

**SUMMARY OF CHANGES**

Subcommittee D02.B0 has identified the location of selected changes to this standard since the last issue (D8047 – 16) that may impact the use of this standard. (Approved May 1, 2017.)

- (1) Subsection 3.2.1, aeration definition revised with “lubricants” replacing “liquids.”
- (2) Subsection 11.1.2 revised.
- (3) Subsections 13.1.2.1 and 13.1.3.1 revised to provide guidance for determining precision when only one test result is available.

*ASTM International takes no position respecting the validity of any patent rights asserted in connection with any item mentioned in this standard. Users of this standard are expressly advised that determination of the validity of any such patent rights, and the risk of infringement of such rights, are entirely their own responsibility.*

*This standard is subject to revision at any time by the responsible technical committee and must be reviewed every five years and if not revised, either reapproved or withdrawn. Your comments are invited either for revision of this standard or for additional standards and should be addressed to ASTM International Headquarters. Your comments will receive careful consideration at a meeting of the responsible technical committee, which you may attend. If you feel that your comments have not received a fair hearing you should make your views known to the ASTM Committee on Standards, at the address shown below.*

*This standard is copyrighted by ASTM International, 100 Barr Harbor Drive, PO Box C700, West Conshohocken, PA 19428-2959, United States. Individual reprints (single or multiple copies) of this standard may be obtained by contacting ASTM at the above address or at 610-832-9585 (phone), 610-832-9555 (fax), or [service@astm.org](mailto:service@astm.org) (e-mail); or through the ASTM website ([www.astm.org](http://www.astm.org)). Permission rights to photocopy the standard may also be secured from the Copyright Clearance Center, 222 Rosewood Drive, Danvers, MA 01923, Tel: (978) 646-2600; <http://www.copyright.com/>*