



Standard Practice for Analysis of Liquefied Natural Gas (LNG) by Fiber-Coupled Raman Spectroscopy¹

This standard is issued under the fixed designation D7940; the number immediately following the designation indicates the year of original adoption or, in the case of revision, the year of last revision. A number in parentheses indicates the year of last reapproval. A superscript epsilon (ϵ) indicates an editorial change since the last revision or reapproval.

1. Scope

1.1 This standard practice is for both on-line and laboratory instrument-based determination of composition for liquefied natural gas (LNG) using Raman spectroscopy. The basic methodology can also be applied to other light hydrocarbon mixtures in either liquid or gaseous states, if the needs of the application are met, although the rest of this practice refers specifically to liquids. From the composition, gas properties such as heating value and the Wobbe index may be calculated. The components commonly determined according to this test method are CH₄, C₂H₆, C₃H₈, i-C₄H₁₀, n-C₄H₁₀, iC₅H₁₂, n-C₅H₁₂, neo-C₅H₁₂, N₂, O₂. The applicable range of this standard is 200 ppmv to 100 mol %. Components heavier than C5 are not measured as part of this practice.

NOTE 1—Raman spectroscopy does not directly quantify the component percentages of noble gases, however, inerts can be calculated indirectly by subtracting the sum of the other species from 100 %.

1.2 The values stated in SI units are to be regarded as standard. No other units of measurement are included in this standard.

1.3 *This standard does not purport to address all of the safety concerns, if any, associated with its use. It is the responsibility of the user of this standard to establish appropriate safety and health practices and determine the applicability of regulatory limitations prior to use.*

2. Referenced Documents

2.1 *ASTM Standards:*²

[D3588 Practice for Calculating Heat Value, Compressibility Factor, and Relative Density of Gaseous Fuels](#)

[D4150 Terminology Relating to Gaseous Fuels](#)

[E691 Practice for Conducting an Interlaboratory Study to Determine the Precision of a Test Method](#)

¹ This test method is under the jurisdiction of ASTM Committee D03 on Gaseous Fuels and is the direct responsibility of Subcommittee D03.12 on On-Line/At-Line Analysis of Gaseous Fuels.

Current edition approved June 1, 2014. Published July 2014. Originally approved in 2014. DOI: 10.1520/D7940-14.

² For referenced ASTM standards, visit the ASTM website, www.astm.org, or contact ASTM Customer Service at service@astm.org. For *Annual Book of ASTM Standards* volume information, refer to the standard's Document Summary page on the ASTM website.

[D1945 Test Method for Analysis of Natural Gas by Gas Chromatography](#)

[D1946 Practice for Analysis of Reformed Gas by Gas Chromatography](#)

[D7833 Test Method for Determination of Hydrocarbons and Non-Hydrocarbon Gases in Gaseous Mixtures by Gas Chromatography](#)

2.2 *BS EN Standards:*³

[BS EN 60079-28 Explosive Atmospheres. Protection of Equipment and Transmission Systems using Optical Radiation](#)

[BS EN 60825-1 Safety of Laser Products Part 1: Equipment Classification, Requirements and User's Guide](#)

2.3 *ISO Standards:*⁴

[ISO 6974-5 Natural Gas—Determination of Composition with Defined Uncertainty by Gas Chromatography, Part 5: Determination of nitrogen, carbon dioxide and C1 to C5 and C6+ hydrocarbons for a laboratory and on-line process application using three columns](#)

3. Terminology

3.1 *Definitions:* Refer to [D4150](#) for definitions related to gaseous fuels.

3.2 *Definitions of Terms Specific to This Standard:*

3.2.1 *Accumulations, n*—while the exposure time is optimized to control the amount of light entering the camera for a single exposure, multiple exposures can be co-added to improve signal-to-noise. The number of exposures co-added are referred to as accumulations.

3.2.2 *charge-coupled device, n*—silicon based two dimensional light sensor characterized by possessing a grid of potential energy wells where light-generated free electrons collect and then are read out sequentially.

3.2.3 *charge-coupled device (CCD) binning, v*—process of combining “bins” or pixel wells on the CCD.

3.2.4 *Exposure Time, n*—the CCD converts photons to electrons over time for a measurement. The exposure time

³ Available from British Standards Institution (BSI), 389 Chiswick High Rd., London W4 4AL, U.K., <http://www.bsigroup.com>.

⁴ Available from International Organization for Standardization (ISO), 1, ch. de la Voie-Creuse, CP 56, CH-1211 Geneva 20, Switzerland, <http://www.iso.org>.

indicates the amount of time allocated for capturing photons. The number of electrons is counted at the end of the allotted exposure time via a binning process.

3.2.5 *incident light, λ_i, n* —monochromatic light illuminated into sample.

3.2.6 *Raman Scattering Effect, n* —an energy transfer process between photons and molecules. In this photon-molecule interaction, scattered light has a different wavelength compared to the incident wavelength. The Raman wavelength shift spectrum is unique for each molecule because the shift is dependent upon the molecular bonding structures.

3.2.7 *Raman spectroscopy, n* —a type of molecular vibration spectroscopy in which a laser is used to excite virtual energy states in the molecules being illuminated, which then decay, producing new photons that are the sum and difference between the laser and the vibrational frequencies. These new photons are then collected and analyzed to determine the vibrational spectrum of the molecules.

3.2.8 *Raman spectrum, n* —plot of intensity against Raman wavelength shift.

3.2.9 *scattered light, λ_s* —scattered light as a result of the Raman scattering effect

3.2.10 *signal strength, n* —a measure of the amount of Raman-scattered photons reaching the CCD. Usually some scaled combination of raw areas of peaks from compounds expected to be present in LNG.

3.2.11 *wavenumber, n* —abbreviated as cm^{-1} ; method of specifying the wavelength of optical radiation. Raman bands are constant wavenumber shifts from the excitation source independent of the wavelength of that source.

3.3 *Acronyms:*

3.3.1 *GC*—Gas chromatograph

3.3.2 *GHV*—Gross Heating Value

3.3.3 *LNG*—Liquefied natural gas

3.3.4 *LPG*—Liquefied petroleum gas

3.3.5 *NIST*—National Institute of Standards and Technology

4. Summary of Practice

4.1 Measurement of the volume fractions of individual molecular species contained in a liquid stream of interest such as LNG is accomplished by obtaining and analyzing Raman spectra (Fig. 1). Monochromatic light from a laser is directed down a fiber-optic cable through a sample-compatible probe optic and into the liquid to be measured. Monochromatic photons interact with the molecules of the liquid via the Raman effect to produce new photons whose wavelengths have been shifted in proportion to vibration frequencies of the molecules. These new, shifted photons are collected through the same optics that delivered the original monochromatic light and are directed down a separate fiber that is connected to a detection module. The detection module contains a spectrograph, which directs photons of different wavelengths to different pixels on a CCD detector. The CCD pixels integrate the photons falling on them into a digital signal, whose value is proportional to the number of photons. Thus, a spectrum is produced, representing a histogram charting the number of photons detected at each wavelength, corresponding to the number of molecules with particular vibration frequencies. The spectra can be mathematically processed to yield the molecular composition of the liquid. Using standards such as Practice D3588, the energy content, and indices such as the Wobbe index, can be calculated from the composition information.

5. Significance and Use

5.1 The composition of liquefied gas fuels (LNG, LPG) is important for custody transfer and production. Compositional determination is used to calculate the heating value, and it is important to ensure regulatory compliance. Compositional

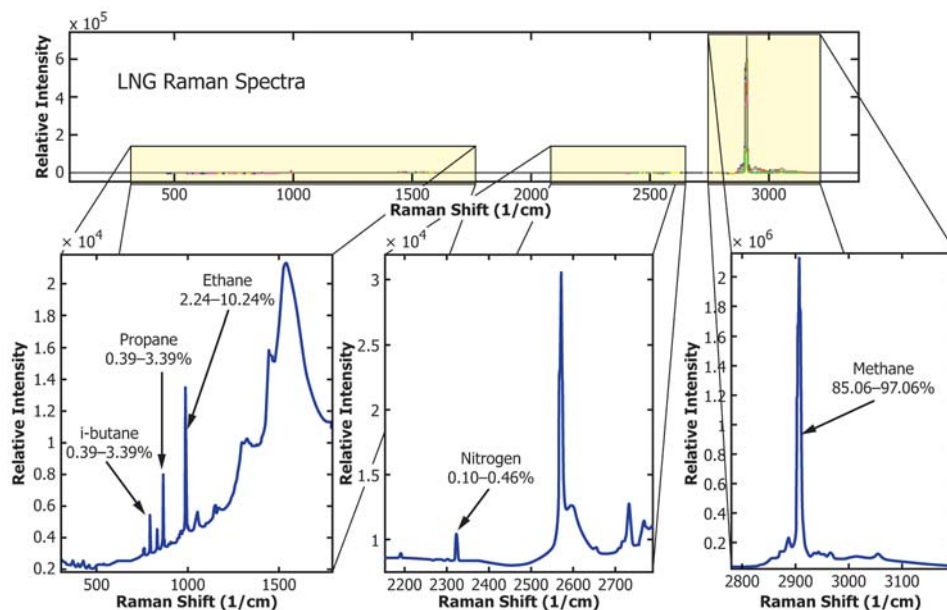

FIG. 1 LNG Raman Spectra

determination is also used to optimize the efficiency of liquefied hydrocarbon gas production and ensure the quality of the processed fluids.

5.2 Alternatives to compositional measurement using Raman spectroscopy are described in Test Method D1945, Practice D1946, and Test Method D7833.

5.3 The advantage of this standard over existing standards mentioned in 5.2 above, is that Raman spectroscopy can determine composition by directly measuring the liquefied natural gas. Unlike chromatography, no vaporization step is necessary. Since incorrect operation of on-line vaporizers can lead to poor precision and accuracy, elimination of the vaporization step offers a significant improvement in the analysis of LNG.

6. Interferences

6.1 Cosmic rays may be detected by the CCD, thus interfering with the Raman spectrum. Typically, a data collection process and algorithm is used to eliminate this consideration. Spectra are taken in pairs and mathematically compared to each other to determine if a cosmic ray has excited specific pixels, which can then be excised from the data set

6.2 Thermally generated electrons add to the true scatter spectrum. This effect is minimized by detector design and manufacturing as well as cooling, and the remaining thermal background is subtracted.

6.3 The standard is intended for sample locations where the sample phase is entirely liquid. Mixed-phase (gas and liquid) or the presence of a significant amount of bubbles due to insufficient insulation or cavitation may impact the precision and accuracy.

7. Apparatus

7.1 *Analyzer Base Unit* (Fig. 2)—The base unit contains the electrically powered system components including the laser with associated safety devices, detection module, control electronics, data communication equipment, human/machine interface, and environmental control equipment. This is typically mounted inside an enclosure suitable to the installation site.

7.1.1 *Laser*—Generates monochromatic light for the creation of a Raman signal within the sample. To be effective, the laser shall have a narrow-enough line width with a stable-enough power output and wavelength so as not to compromise the generation and analysis of the Raman spectra. The wavelength of the laser must match the design specifications of the detector module such that the Raman photons produced are in the wavelength range that the detector module can detect. In addition, the laser photons and Raman photons must be of such a wavelength that they can be transmitted through a fiber-optic cable with minimal attenuation. Generally a laser of wavelength 785 nm has been found to work well, but other lasers in the range of 500 to 800 nm may also be possible, providing the detector is chosen appropriately. The laser shall also have features that make it compatible with both explosive atmosphere safety (see EN60079-28) as well as eye safety (see EN 60825-1). This will generally include a remote-capable power-interlocking system, a redundant power-monitoring system, and a visible operation indicator light system. Typical performance values meet these criteria:

7.1.1.1 Power stability $\pm 5\%$ long term over operating temperature range (0 to 45 °C),

7.1.1.2 Line width $\leq 1 \text{ cm}^{-1}$, and

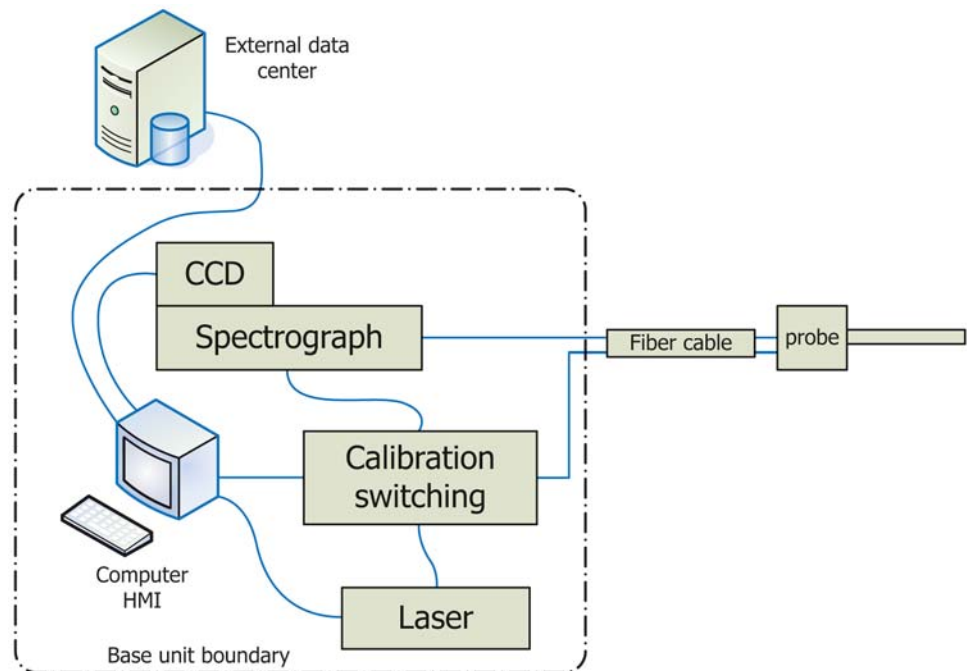

FIG. 2 Analyzer Base Unit

7.1.1.3 Wavelength stability 0.005 nm short term (several minutes) and 0.05 nm long term (years).

7.1.2 Detection Module

7.1.2.1 *Spectrograph*—Optical device for separating the Raman signal photons by wavelength and imaging them onto a detector. To provide sufficient separation between molecular vibration frequencies and allow the detection of Raman photons that carry this information, the spectrograph shall combine high spatial and spectral resolution; high optical throughput; and stability over time, temperature, and environmental changes. The spectrograph shall also provide sufficient free spectral range to capture all the vibration frequencies of interest. Spectrographs using holographic transmission gratings and refractive imaging optics are ideally suited to this task. The spectrograph also shall include a notch or edge filter to block excess un-shifted laser light without significantly affecting signal photons. The following typical performance values meet these criteria:

- (1) *Spectral range*— ≤ 150 to ≥ 3500 cm^{-1}
- (2) *Spectral resolution*— ≤ 7 cm^{-1}
- (3) *Spectral thermal stability*— ≤ 0.1 $\text{cm}^{-1}/^{\circ}\text{C}$ band shift,
- (4) *Optical throughput*—Numerical aperture (NA) of spectrograph matched to fiber NA (typically f/1.8), and
- (5) *Notch or edge filter*— ≥ 8 optical density at laser wavelength and ≥ 80 % transmission beyond 200 cm^{-1} .

7.1.2.2 *CCD*—The CCD detector is a silicon-chip-based two-dimensional array of light-sensitive pixels having the characteristics of high-quantum efficiency, high linearity, adequate dynamic range, with very low background noise, coupled with a sufficient number of pixels to support system resolution requirements. The low-noise characteristic is due to a combination of the design of the chip, cooling of the chip to reduce thermally generated signals, and low-read noise electronics. The chip shall be contained in a hermetic vacuum Dewar to prevent ambient contamination from interfering with spectral accuracy. Typical performance values:

- (1) *Quantum efficiency*— ≥ 40 % at spectral range center;
- (2) *Spectral range*—At least 4 % quantum efficiency from 400 to 1050 nm;
- (3) *Dynamic range*—16-bit digital, with ≥ 50 000 electron quantum well capacity;
- (4) *Read noise*— ≤ 10 electrons; and
- (5) *Dark count*— ≤ 0.5 electrons/pixel/second, typically requires cooling to at least -30 $^{\circ}\text{C}$.

7.1.2.3 *Spectrum Standard*—Light source of known spectrum used to standardize/calibrate the detection module and provide the correct mapping of scattered wavelength to physical CCD pixel coordinates/location. Typically, an atomic emission source such as a neon light is used for this purpose.

7.1.2.4 *Raman Shift Standard*—A physical sample having known Raman shift characteristics used to determine the operating wavelength of laser module and correct for any short-term or accumulated error. The position of the spectral band(s) of this material can be used to calculate the operational wavelength of the laser:

$$\lambda_i = \frac{1}{\left(\bar{\nu} + \frac{1}{\lambda_s}\right)} \quad (1)$$

where λ_i is the incident wavelength (the operational wavelength of the laser) in cm, λ_s is the measured wavelength of the Raman band in cm, and $\bar{\nu}$ is the accepted standard position of the Raman band of the reference material in wave-numbers.

7.1.3 *Fiber-Optic Cable*—Typically contains two individual optical fibers, one of which carries laser light to the sample, with the other returning the Raman signal back to the detection module. For Raman systems using lasers with the theoretical ability to exceed the limits set forth in EN 60079-28, there shall be some form of breakage detection or armoring associated with the cable. A typical approach is to incorporate into the cable a pair of electrical conductors that carry an intrinsically safe level of current that is integral to the laser power interlock. Interruption of this current by cable damage shuts down the laser.

7.1.3.1 *Excitation Fiber*—Carries incident light from the analyzer to the probe. Should be low OH all-glass fiber.

7.1.3.2 *Collection Fiber*—Carries scattered light from the probe to the analyzer. Should be low OH all-glass fiber.

7.1.3.3 *Interlock Conductors*—28-gauge or greater copper with capacitance and inductance sufficiently low to meet industry standard (IS) barrier requirements.

7.1.4 *Sample Probe*—The sample probe interfaces the fiber cable to the sample stream. It shall be constructed of materials compatible with the sample stream and be able to maintain stable optical performance from cryogenic temperatures in the case of LNG measurement to ambient. The probe contains a hermetically sealed window separating the optics from the sample stream. The primary functions of the probe are: removal of the Raman signal generated by laser light traveling through the excitation fiber (which would contaminate the sample spectra), imaging the laser light into the sample, superimposing an image of the collection fiber onto the illuminated sample volume, removing the majority of the unshifted laser light before leaving the probe (again to eliminate background signals), and finally, providing efficient delivery of the excitation light into, and efficient collection of the Raman signal out of, the stream to be measured.

7.1.4.1 *Optical Assembly*—Collection of lenses and filters constructed to operate from ambient to cryogenic temperatures (-190 $^{\circ}\text{C}$) or ambient to above 150 $^{\circ}\text{C}$. Shall be vibration- and shock-resistant (100-G shock, 10-G full spectral vibration up to 500 Hz).

7.1.4.2 *Housing*—Shall be made from a material that is chemically and physically compatible with the stream being measured. It is typically 316 stainless steel. The probe shall be rigid enough to withstand the hydrodynamic forces it will experience when installed in the sample stream. It shall incorporate features to hermetically seal the window and fiber feed-throughs to isolate the optics from the sample and ambient environment. The housing shall have process-compatible mounting features; typically a flange or compression fitting.

7.1.4.3 *Window*—The window sealing mechanism shall be chemically compatible with the materials being analyzed and shall have low-fluorescent background so as not to obscure spectral features. The window material and construction shall be able to withstand the sample pressure. Windows are typically constructed of ultra-pure sapphire for strength, chemical resistance, and to reduce spectral contamination. It shall be constructed such that it can maintain a hermetic seal when subjected to a standard 7 J 2.5-cm diameter steel ball impact test (per pressure vessel and hazardous atmosphere requirements).

7.1.5 *Computer Control System and User Interface*—Typically, a computer subsystem is used to interface with the CCD, collect spectra, perform calculations, as well as monitor diagnostic sensors and provide a user interface.

7.1.6 *Software*—Software is used for the following functions:

7.1.6.1 Perform Raman wavelength shift calculations,

7.1.6.2 Produce spectrum of intensity versus Raman wavelength shift,

7.1.6.3 Determine species present,

7.1.6.4 Calculate relative abundance of species present and perform calculations of quantities based on these abundances,

7.1.6.5 Track key diagnostic factors such as temperatures, spectral intensity, and laser power, and

7.1.6.6 Maintain and check instrument calibration and drift.

8. Hazards

8.1 Probes can be installed in sample streams that operate at high pressure and temperature. Extra care should be taken to assure the probe cannot be accidentally ejected from the stream interface.

8.2 The probe shall be installed in such a manner that explosion hazards are eliminated in the event of an explosive sample mixture being present, either by limitation of laser power to below that which can cause ignition, or by interlock, in which a physical switch senses when liquid level is about to fall below the probe and shuts the laser off.

8.3 This test method involves the use of a Class IIIb laser, which, if handled improperly, can cause eye damage. Always check the emission status of the laser when performing service work and ensure that the laser is either off or personnel are wearing appropriate laser protection eyewear.

9. Sampling, Test Specimens, and Test Units

9.1 The probe tip shall be mounted in the pipe or vessel containing the liquid to be measured and positioned into the flow at least 2in., or 10 % of the pipe diameter, in from the wall of the pipe or container, to ensure representative sampling.

9.2 The probe should be mounted within 45° of horizontal such that liquid immersion of the tip is assured.

9.3 The temperature and pressure shall be such as to ensure that the sample is in the liquid phase.

9.4 The probe should be engineered such that it is within the fatigue limits of expected vortex shedding induced vibrations.

9.5 The probe window and housing structure shall be designed to withstand the expected pressure and temperature of the sample being measured with a reasonable safety factor.

10. Preparation of Apparatus

10.1 The laser module shall be operated within its specified ambient temperatures range to ensure the stability of the incident light. The method will be successful if the laser remains stable to 0.1 cm^{-1} during data collection. The laser shall be allowed sufficient warm up time to reach necessary stability (typically in the range of 10 min).

10.2 Spectrographs can be sensitive to changes in temperature. Aberrations can occur as a result of thermal contraction or expansion. Some combination of the following shall occur: the temperature surrounding the spectrograph is held constant (less than 1 °C change), an automated system is used to track and correct for spectral calibration and aberrations, or design features are incorporated into the spectrograph opto-mechanics to correct passively.

10.3 Charge Coupled Device (CCD)

10.3.1 The CCD should be operated at low temperatures, typically -30 °C or colder, to minimize thermally generated electrons. Generally, 10 minutes or more are required for detectors to stabilize at the operational temperature.

10.3.2 *Set Spectral Acquisition Time*—Total spectral acquisition times shall be long enough to allow sufficient Raman spectral signal-to-noise ratio to achieve the required analysis precision. A CCD pixel can hold a maximum number of electrons (typically $\geq 60\,000$). After this limit, no more photons can be converted to electrons. Saturation of the pixel occurs at this point, which distorts the intensity of the spectrum. The exposure time shall be short enough to ensure saturation does not occur. Thus, a spectral acquisition consists of accumulating (or adding together) a number of individual exposures, each of which is short enough to avoid saturation. Typically, each individual exposure will range from a few tenths of a second to several seconds. The number of individual exposures added together to produce a spectral acquisition with suitable signal levels will range from two to hundreds of accumulations and will depend on the amount of laser power being used and the overall efficiency of the optical data collection path.

11. Calibration, Standardization, and Validation

11.1 During the development of the analytic method, correlations are established between spectra and the sample species by taking spectra of known samples. Because of the inherent linearity of the Raman effect, the method will correctly measure sample concentrations as long as the Raman spectra are valid. Thus, the primary task to ensure analyzer calibration is to ensure the spectra are calibrated and standardized before the analyzer is commissioned. There also needs to be a means to ensure this calibration remains valid over time by using validation approaches. A spectrum is essentially a two-dimensional chart with the number of detected photons on the vertical or intensity axis and the wavelength of those photons on the horizontal axis. The mathematical method used to generate analytic results from the spectra relies on knowing the wavelength positions and relative intensities of the various

spectral features associated with the components. Each of these axes is calibrated by optical means.

11.2 Wavelength Axis—For the wavelength axis calibration to be standardized, and thus to know which detected vibration frequencies correspond to given spectrum features, it is necessary to determine the particular wavelength falling on each group of CCD pixels. This is done by exposing the detector to light that is comprised of known individual wavelengths. Typically, this is done by arranging for light from a neon bulb to be periodically and automatically imaged onto the detector. The emission spectra of neon is comprised of a large number of individual wavelengths that are known to great precision, and the physics associated with neon light ensure wavelength stability through time and over a wide range of environmental conditions, thus establishing standardization. By recording where each neon wavelength falls on the CCD, a map can be generated relating pixel to wavelength. Any changes in the position of a given wavelength on the detector as a result of thermal or mechanical effects can thus be corrected by measuring the change with the neon spectra. Ongoing validation is done analogously.

11.2.1 Example Neon Spectrum—*Y-axis*: counts, *X-axis*: Raman shift (cm^{-1}) (see Fig. 3).

11.3 Intensity Axis Calibration—Optical Path Wavelength Transmission Efficiency—The detection efficiency of signal photons traveling from the sample, through the probe optics, through the fiber, and finally, to the detection module, varies with wavelength. Thus, different molecular vibrations have different detection efficiencies. These efficiencies are unique to each instrument. Thus, for a method to be valid and accurate, these variations shall be corrected to yield accurate relative abundance calculations. During the system installation process, just before commissioning, reference light with a known intensity versus wavelength profile is transmitted through the entire optical path by exposing it to the probe collection aperture. A spectrum is taken of this light source, which is then divided by the known profile, and the result is then stored as a reference spectrum on the instrument being fabricated. This reference spectrum is then used to correct subsequent sample

spectra to obtain spectra that are independent of the spectrograph throughput. There are several ways to produce this reference light.

11.3.1 Broadband Light from Incandescent Bulb—The light source is typically a tungsten halogen bulb with an integral diffuser to ensure uniform illumination, driven by constant current electronics to ensure stable operation. The bulb is typically calibrated relative to a National Metrology Institute (NMI) traceable reference source such as National Institute of Standards and Technology (NIST) thus creating a table of values relating the radiative intensity of the bulb/diffuser combination at each wavelength over the spectral range of the analyzer. The bulb/diffuser combination is presented to the collection aperture of the probe and calibration spectra are taken as described above. The bulb must be recertified at the factory on a yearly basis. This is the preferred approach for performing intensity calibration.

11.3.2 Fluorescent Material—A number of materials readily fluoresce when illuminated by laser light producing a broadband light that has a known spectral profile. NIST produces several types of glass doped with dyes that are specifically engineered to calibrate Raman instruments. The glass is presented to the active probe beam and a reference spectrum is taken as described above.

11.3.3 Raman Spectra of Reference Material—Instead of a broadband light source, the Raman spectrum of a known mix of materials can be used as a reference. The mix should contain each of the materials, in gravimetrically established percentages, that are intended to be measured during analyzer operation. The relative intensity of each band in the reference spectrum will be established by the known Raman signature of the material and its known molar percentage of the mix.

11.3.4 Neon Spectra—Although not used for intensity axis calibration and standardization, the same light source used for wavelength calibration and standardization can be used to validate the intensity axis. Each time a neon spectrum is collected, a series of ratios of the individual peaks is calculated. The most robust practice is to generate a ratio of each peak with respect to other peaks being used for the calibration

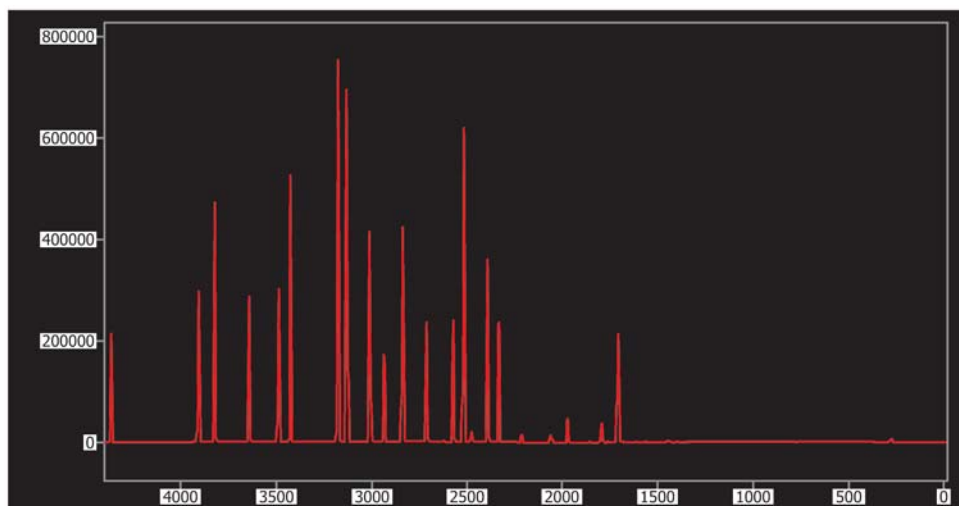

FIG. 3 Example Neon Spectrum

(typically, this is eight to ten peaks). A set of these ratio values are then stored on the analyzer during commissioning to be used as a validation reference.

11.4 *Ongoing and Field Calibration/Validation*—As presented in section 11.2, the wavelength axis is calibrated and automatically validated periodically. Similarly, the intensity axis can be validated by periodically exposing the probe to one of the reference light source options covered in 11.3.1 through 11.3.4. This is typically done annually or at a convenient time when the sample point is out of service. In some cases, it is desired to check the intensity axis calibration without removing the probe from its stream mounting (this is often the case in LNG installations). This can be accommodated by considering that the system components that can effect intensity calibration are: the probe, the fiber-optic cables, and the detection module. The detection module can be checked for any changes in intensity calibration by comparing the ratios of neon peak heights as discussed in 11.3.4. Note that this is done automatically and periodically. The fiber-optic cable and the probe are passive optical devices that are not subject to wear or aging absent external modification or contamination and, thus, do not require ongoing validation. Any change that could affect intensity calibration is typically caused either by contamination of the probe window or fiber connections, or physical damage of the fiber or probe. Either of these two scenarios would produce noticeable effects in the Raman spectra that can be detected and acted upon. The two most likely effects are a large drop in signal or a large rise in the baseline background of the spectra, or both.

12. Conditioning

12.1 The liquid sample shall be free of vapor or bubbles. While the instrument is tolerant of some bubbles, too many bubbles will decrease the signal to the extent that precision will be compromised and the instrument software will issue an alarm. The signal strength will be reduced as the percentage of the volume that is gas versus liquid increases. Because the analytic method relies on calculating ratios between spectral features, decreases in signal strength do not directly translate into measurement errors. Rather, the signal strength decrease translates into a reduction in precision. The analyzer software has automatic thresholds that will raise alarms if the signal strength falls too low for the required measurement precision.

13. Procedure

13.1 Raman instruments used in the analysis of LNG are typically “turn-key” instruments that require little operator interaction during sample collection and data processing. A typical analysis is performed by clicking “start” on the graphical user interface and waiting for results.

14. Calculation

14.1 Calculations are generally internal to the instrument operational software and rely on a “method” file developed specifically for the sample stream being measured. The method is a set of mathematical operations that convert the spectral data into concentration values. The concentration values may subject to further calculations to produce energy content values

or relevant indices such as Wobbe index in accordance with standards such as D3588. A general overview of the method development process is contained in Appendix X1.

15. Report

15.1 The equipment reports molecules identified and their relative abundance. Energy content, Wobbe index, density, and other calculations can be reported as well.

15.2 See Fig. 4 for an example report.

16. Precision and Bias

NOTE 2—A formal interlaboratory study according to Practice E691 has not yet been completed. Standard transfer for LNG in particular presents a problem due to the fact it is not practical to create and ship identical liquid cryogenic reference samples to multiple locations for testing. In lieu of such measurements, three different analyzers have gone through field trials at four different LNG terminals, with the results correlated to both the on-line vaporizer/GC and laboratory GC measuring grab samples. An example of these results can be found in Fig. 5. In addition a third-party metrology resource is being utilized to develop a set of standards that will define accuracy for LNG and collect spectra of those standards.

16.1 *Precision*—The precision of this test method is determined by the statistical examination of field trial data using repeat measurements during a stable period of LNG unloading. In addition, a surrogate standard approach is used for the precision of multiple instruments using measurements of a pure material and performing statistical analysis of the peak ratios.

16.1.1 *Repeatability*—The difference between successive test results obtained by the same operator with the same apparatus under constant operating conditions on identical test material would, in the long run, in the normal and correct operation of the test method, exceed the following values by only one case in twenty. These data refer to LNG field data taken during stable unloading conditions over the course of several months. The repeatability was calculated using the



FIG. 4 Example Report

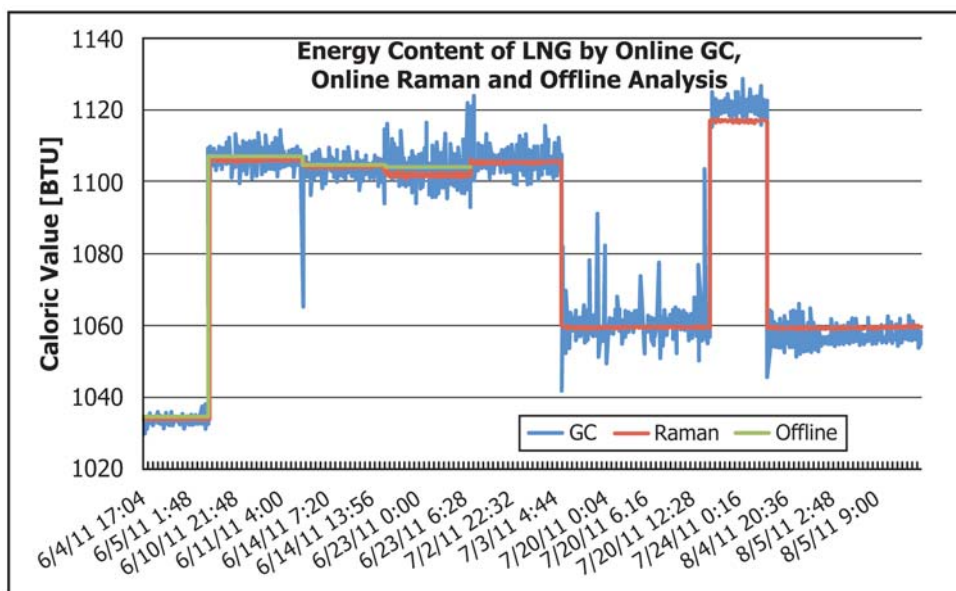

FIG. 5 Example Data

algorithm as described in ISO 6974-5. The test results have demonstrated the repeatability of the Gross Heating Value to be 0.020 % relative. Repeatability for GHV above 0.05 % should be considered suspect. For reference, the measured and calculated repeatability of the vaporizer/GC analyzer was 0.2 %.

16.1.2 *Reproducibility*—As stated under the main heading of this section, standard preparation is not possible for an interlaboratory study. In lieu of LNG samples, cyclohexane band ratios from a variety of instruments are proposed as a measure of reproducibility. See Table 1 for typical historical tolerances on cyclohexane measurements.

16.2 *Accuracy*—As stated under the main heading of this section, the accuracy has been determined by both the use of laboratory standards (cryostat measurements of gravimetric standards of LNG components) and field trials in which reference methods such as online gas chromatography (GC) and laboratory GC. As with any analytical method, as improved reference standards are obtained, there may be updates to the method that result in improved accuracy much like the way molar heating values are periodically updated for the use of calculating the gross heating value of a mixture. A study is currently underway in which an independent metrology resource is creating traceable LNG accuracy standards and measuring the spectra of these standards.

TABLE 2 LNG Field Data Taken During Stable Unloading Conditions

Component, mol %	Repeatability, mol % 1-sigma
<0.019	0.006
0.02 to 0.49	0.010
Over 5.0	0.03

16.3 *Bias*—The primary source of bias for a Raman analyzer using a method such as is outlined in Appendix X1 is associated with intensity calibration. Changes in the intensity transfer characteristic will effectively modify the response factors for the various bands being used by the prediction model, thus causing a prediction error that, while still precise, will be inaccurate. Mitigating this bias can be achieved by properly calibrating and validating the intensity axis as prescribed in section 11.3. The other main source of potential bias is related to the accuracy of the reference sample used to establish the band response values. As stated in section 11.1 the band response values were originally established by taking measurements of cryogenic liquids created from gravimetrically produced gas reference samples. These response factors were found to have an approximately 0.5% bias error relative to the averaged measurements of three different vaporizer/GC systems over the course of several hundred data collection events. The response factors in the final model were then

TABLE 1 Cyclohexane Band Tolerances

Nominal Peak Position	Integration Start	Integration Stop	Low Baseline Avg Start	Low Baseline Avg Stop	High Baseline Avg Start	High Baseline Avg Stop	Nominal Area Relative to 801.8 Band	Tolerance
801.80	760	840	750	770	830	850	1	0
1028.2	960	1100	950	970	1090	1110	0.59	0.044
1266.4	1220	1315	1210	1230	1305	1325	0.51	0.038
1444	1380	1510	1370	1390	1500	1520	0.62	0.047
2664-2939	2550	3100	2540	2560	3090	3110	10.69	1.604

adjusted to remove this bias. Additional bias adjustments may be made as improved accuracy standards are available.

17. Keywords

17.1 BTU; heating value; Liquefied Natural Gas; molecular composition; relative abundance; Raman; Spectroscopy; Wobbe Index

APPENDIX

(Nonmandatory Information)

X1. METHOD DEVELOPMENT OVERVIEW

X1.1 Because Raman spectroscopy often produces more than one response band per molecule, there is more than one way to develop a method to quantitate hydrocarbons present in a sample or sample stream. The typical steps include:

X1.1.1 Develop a set of liquid calibration standards covering at least the desired range such that the concentrations of the standards are minimally correlated with each other. One way to develop the standard is to use Design of Experiments software and a mixture design option.

X1.1.2 Collect spectra from these standards.

X1.1.3 Determine which peaks in the standards to use for quantitating each component. Some criteria used for this decision include the magnitude of the peak response, the amount of overlap with other peaks, and the shape of the peak.

X1.1.4 Determine the best way to reduce the peak to a number representing how the peak varies with concentration. Common methods include baseline-corrected area or height.

X1.1.5 Regress the peak areas or fractional areas against concentration. There are a variety of regression methods that may be used to accomplish this, and the reader is referred to any standard statistics book for a discussion, including the references listed in the Bibliography.

X1.1.6 The regression equations obtained are then used to convert peaks from an unknown spectrum into concentration information.

X1.1.7 As a final step, a mass balance may be performed, either by normalizing to 100 %, or by treating the difference between the sum of the other components and 100 % as balance components.

BIBLIOGRAPHY

- (1) Beebe, K. R., Pell, R. J., and Seasholtz, M. B., *Chemometrics: A Practical Guide*. New York, NY: John Wiley & Sons, 1998.
- (2) Gemperline, Paul, ed. *Practical Guide to Chemometrics, 2nd Edition*. Boca Raton, FL: CRC Taylor and Francis, 2006.

ASTM International takes no position respecting the validity of any patent rights asserted in connection with any item mentioned in this standard. Users of this standard are expressly advised that determination of the validity of any such patent rights, and the risk of infringement of such rights, are entirely their own responsibility.

This standard is subject to revision at any time by the responsible technical committee and must be reviewed every five years and if not revised, either reapproved or withdrawn. Your comments are invited either for revision of this standard or for additional standards and should be addressed to ASTM International Headquarters. Your comments will receive careful consideration at a meeting of the responsible technical committee, which you may attend. If you feel that your comments have not received a fair hearing you should make your views known to the ASTM Committee on Standards, at the address shown below.

This standard is copyrighted by ASTM International, 100 Barr Harbor Drive, PO Box C700, West Conshohocken, PA 19428-2959, United States. Individual reprints (single or multiple copies) of this standard may be obtained by contacting ASTM at the above address or at 610-832-9585 (phone), 610-832-9555 (fax), or service@astm.org (e-mail); or through the ASTM website (www.astm.org). Permission rights to photocopy the standard may also be secured from the Copyright Clearance Center, 222 Rosewood Drive, Danvers, MA 01923, Tel: (978) 646-2600; http://www.copyright.com/