



Designation: D7928 – 17

Standard Test Method for Particle-Size Distribution (Gradation) of Fine-Grained Soils Using the Sedimentation (Hydrometer) Analysis¹

This standard is issued under the fixed designation D7928; the number immediately following the designation indicates the year of original adoption or, in the case of revision, the year of last revision. A number in parentheses indicates the year of last reapproval. A superscript epsilon (ϵ) indicates an editorial change since the last revision or reapproval.

1. Scope

1.1 This test method covers the quantitative determination of the distribution of particle sizes of the fine-grained portion of soils. The sedimentation or hydrometer method is used to determine the particle-size distribution (gradation) of the material that is finer than the No. 200 (75- μm) sieve and larger than about 0.2- μm . The test is performed on material passing the No. 10 (2.0-mm) or finer sieve and the results are presented as the mass percent finer versus the log of the particle diameter.

1.2 This method can be used to evaluate the fine-grained fraction of a soil with a wide range of particle sizes by combining the sedimentation results with a sieve analysis resulting in the complete gradation curve. The method can also be used when there are no coarse-grained particles or when the gradation of the coarse-grained material is not required or not needed.

NOTE 1—The significant digits recorded in this test method preclude obtaining the grain size distribution of materials that do not contain a significant amount of fines. For example, clean sands will not yield detectable amounts of silt and clay sized particles, and therefore should not be tested with this method. The minimum amount of fines in the sedimentation specimen is 15 g.

1.3 When combining the results of the sedimentation and sieve tests, the procedure for obtaining the material for the sedimentation analysis and calculations for combining the results will be provided by the more general test method, such as Test Methods D6913 (Note 2).

NOTE 2—Subcommittee D18.03 is currently developing a new test method “Test Method for Particle-Size Analysis of Soils Combining the Sieve and Sedimentation Techniques.”

1.4 The terms “soil” and “material” are used interchangeably throughout the standard.

1.5 The sedimentation analysis is based on the concept that larger particles will fall through a fluid faster than smaller particles. Stokes’ Law gives a governing equation used to

determine the terminal velocity of a spherical particle falling through a stationary liquid. The terminal velocity is proportional to the square of the particle diameter. Therefore, particles are sorted by size in both time and position when settling in a container of liquid.

1.5.1 Stokes’ Law has several assumptions which are: the particles are spherical and smooth; there is no interference between the particles; there is no difference between the current in the middle of the container and the sides; flow is laminar; and the particles have the same density. These assumptions are applied to soil particles of various shapes and sizes.

1.6 A hydrometer is used to measure the fluid density and determine the quantity of particles in suspension at a specific time and position. The density of the soil-water suspension depends upon the concentration and specific gravity of the soil particles and the amount of dispersant added. Each hydrometer measurement at an elapsed time is used to calculate the percentage of particles finer than the diameter given by Stokes’ Law. The series of readings provide the distribution of material mass as a function of particle size.

1.7 This test method does not cover procurement of the sample or processing of the sample prior to obtaining the reduced sample in any detail. It is assumed that the sample is obtained using appropriate methods and is representative of site materials or conditions. It is also assumed that the sample has been processed such that the reduced sample accurately reflects the particle-size distribution (gradation) of this finer fraction of the material.

1.8 *Material Processing*—Material is tested in the moist or as-received state unless the material is received in an air-dried state. The moist preparation method shall be used to obtain a sedimentation test specimen from the reduced sample. Air-dried preparation is only allowed when the material is received in the air-dried state. The method to be used may be specified by the requesting authority; however, the moist preparation method shall be used for referee testing.

1.9 This test method is **not** applicable for the following soils:

1.9.1 Soils containing fibrous peat.

¹ This test method is under the jurisdiction of ASTM Committee D18 on Soil and Rock and is the direct responsibility of Subcommittee D18.03 on Texture, Plasticity and Density Characteristics of Soils.

Current edition approved May 1, 2017. Published May 2017. Originally approved in 2016. Last previous edition approved in 2016 as D7928 – 16^{e1}. DOI: 10.1520/D7928-17

1.9.2 Soils containing less than approximately 5 % of fine-grained material (**Note 1**).

1.9.3 Soils containing extraneous matter, such as organic solvents, oil, asphalt, wood fragments, or similar items (**Note 3**).

NOTE 3—If extraneous matter, such as wood, can be easily removed by hand, it is permissible to do so. However, there may be cases where the extraneous matter is being evaluated as part of the material and it should not be removed from the material.

1.9.4 Materials that contain cementitious components, such as cement, fly ash, lime, or other stabilization admixtures.

1.10 This test method may not produce consistent test results within and between laboratories for the following soils. To test these soils, this test method must be adapted and these adaptations documented.

1.10.1 Soils that flocculate during sedimentation. Such materials may need to be treated to reduce salinity or alter the pH of the suspension.

1.10.2 Friable soils in which processing changes the gradation of the soil. Typical examples of these soils are some residual soils, most weathered shales, and some weakly cemented soils.

1.10.3 Soils that will not readily disperse, such as glauconitic clays or some dried plastic clays.

1.11 Samples that are not soils, but are made up of particles may be tested using this method. The applicable sections above should be used in applying this standard.

1.12 *Units*—The values stated in SI units are to be regarded as standard. Except the sieve designations, they are identified using the “alternative” system in accordance with Practice **E11**, such as 3-in. and No. 200, instead of the “standard” of 75-mm and 75- μ m, respectively. Reporting of test results in units other than SI shall not be regarded as non-conformance with this test method. The use of balances or scales recording pounds of mass (lbm) shall not be regarded as nonconformance with this standard.

1.13 All observed and calculated values shall conform to the guidelines for significant digits and rounding established in Practice **D6026**, unless superseded by this test method.

1.13.1 The procedures used to specify how data are collected/recorded and calculated in the standard are regarded as the industry standard. In addition, they are representative of the significant digits that generally should be retained. The procedures used do not consider material variation, purpose for obtaining the data, special purpose studies, or any considerations for the user’s objectives; and it is common practice to increase or reduce significant digits of reported data to be commensurate with these considerations. It is beyond the scope of these test methods to consider significant digits used in analysis methods for engineering data.

1.14 *This standard does not purport to address all of the safety concerns, if any, associated with its use. It is the responsibility of the user of this standard to establish appropriate safety and health practices and determine the applicability of regulatory limitations prior to use.*

1.15 *This international standard was developed in accordance with internationally recognized principles on standard-*

ization established in the Decision on Principles for the Development of International Standards, Guides and Recommendations issued by the World Trade Organization Technical Barriers to Trade (TBT) Committee.

2. Referenced Documents

2.1 ASTM Standards:²

- D653** Terminology Relating to Soil, Rock, and Contained Fluids
- D854** Test Methods for Specific Gravity of Soil Solids by Water Pycnometer
- D1140** Test Methods for Determining the Amount of Material Finer than 75- μ m (No. 200) Sieve in Soils by Washing
- D2216** Test Methods for Laboratory Determination of Water (Moisture) Content of Soil and Rock by Mass
- D2487** Practice for Classification of Soils for Engineering Purposes (Unified Soil Classification System)
- D2488** Practice for Description and Identification of Soils (Visual-Manual Procedure)
- D3740** Practice for Minimum Requirements for Agencies Engaged in Testing and/or Inspection of Soil and Rock as Used in Engineering Design and Construction
- D4220/D4220M** Practices for Preserving and Transporting Soil Samples
- D4318** Test Methods for Liquid Limit, Plastic Limit, and Plasticity Index of Soils
- D4753** Guide for Evaluating, Selecting, and Specifying Balances and Standard Masses for Use in Soil, Rock, and Construction Materials Testing
- D6026** Practice for Using Significant Digits in Geotechnical Data
- D6913** Test Methods for Particle-Size Distribution (Gradation) of Soils Using Sieve Analysis
- E11** Specification for Woven Wire Test Sieve Cloth and Test Sieves
- E100** Specification for ASTM Hydrometers
- E126** Test Method for Inspection, Calibration, and Verification of ASTM Hydrometers

3. Terminology

3.1 Definitions:

3.1.1 For definitions of common technical terms used in this standard, refer to Terminology **D653**.

3.2 Definitions of Terms Specific to This Standard:

3.2.1 *reduced sample, n*—the minus $\frac{3}{8}$ -in. (9.5-mm) sieve or finer material that has been separated from the sample and then worked to reduce the mass while still having sufficient quantity to meet the minimum mass requirements of **Table 1**.

3.2.2 *sample, n*—material collected without limitation on the total mass or size range of particles meeting the minimum mass requirements provided in **Table 1**.

3.2.3 *sedimentation sample, n*—the minus No. 10 (2.0-mm) or finer material that is separated from the reduced sample

² For referenced ASTM standards, visit the ASTM website, www.astm.org, or contact ASTM Customer Service at service@astm.org. For *Annual Book of ASTM Standards* volume information, refer to the standard’s Document Summary page on the ASTM website.

TABLE 1 Minimum Dry Mass Requirements

Maximum Particle Size of Material (99% or more passing)		Minimum Dry Mass	Comments on separating and splitting requirements for sample reduction
Sieve Designation	Particle Size, mm		
6 in.	152.4	500 kg	Several separations
3 in.	76.2	70 kg	Several separations
1 in.	25.4	3 kg	At least one separation
¾ in.	19.1	1.3 kg	Most likely one separation
⅜ in.	9.5	165 g	Separation for sedimentation analysis
No. 10	2.0	50 g	Splitting only

using the separation sieve from which the sedimentation specimen and water content are obtained.

3.2.4 *sedimentation specimen, n*—the material obtained from the sedimentation sample having a maximum particle-size no greater than the No. 10 (2.0-mm) sieve to be used in the sedimentation test and in sufficient quantity to satisfy the minimum mass requirements of [Table 1](#).

3.2.5 *separation sieve, n*—the No. 10 (2.0-mm) sieve or finer ([Note 4](#)) used to separate the reduced sample to obtain the material for the sedimentation sample.

NOTE 4—The methodology for using a sieve finer than the No. 10 (2.0 mm) is not defined in this standard. The methodology used to obtain a representative sample using a sieve finer than the No. 10 (2.0 mm) is not the same as obtaining the representative sample using the No. 10 (2.0 mm) sieve as presented in this standard. Additional effort or steps are necessary to make sure the material passing the finer sieve adequately represents the sample. Such additional effort or steps should be documented if using a sieve finer than the No. 10 (2.0 mm) sieve to obtain the sedimentation specimen.

4. Summary of Test Method

4.1 This test method is used to determine the particle-size distribution (gradation) of material finer than the No. 200 (75- μ m) sieve as a percentage of the mass used in the sedimentation test.

4.2 When the source material contains particles larger than the ⅜-in. (9.5-mm) sieve, a reduced sample passing the ⅜-in. (9.5-mm) sieve shall be obtained using techniques presented in [Test Methods D6913](#) or another standard. This reduced sample shall meet the minimum mass requirements in [Table 1](#) for the ⅜-in. (9.5-mm) sieve. The material is processed using the moist (referee) preparation method unless the material is received in the air-dried state.

4.3 The entire reduced sample is separated using the separation sieve. The sedimentation sample is then split to obtain the appropriate mass for the sedimentation test specimen and a water content test specimen.

4.4 The sedimentation test specimen is mixed with a dispersing agent and test water. The slurry is allowed to condition and is then thoroughly mixed and placed in a cylinder with additional test water. Readings are taken with a hydrometer and thermometer over specific time intervals.

4.5 The mass of particles passing specified particle diameters are calculated and recorded. The results produce a tabulation of particle size versus percent passing that can be graphically presented as a gradation curve. The plot is typically expressed as percent passing/finer than the separation sieve size versus the log of the particle size in millimetres.

5. Significance and Use

5.1 Particle-size distribution (gradation) is a descriptive term referring to the proportions by dry mass of a soil distributed over specified particle-size ranges. The gradation curve generated using this method yields the amount of silt and clay size fractions present in the soil based on size definitions, not mineralogy or Atterberg limit data.

5.2 Determination of the clay size fraction, which is material finer than 2 μ m, is used in combination with the Plasticity Index ([Test Methods D4318](#)) to compute the activity, which provides an indication of the mineralogy of the clay fraction.

5.3 The gradation of the silt and clay size fractions is an important factor in determining the susceptibility of fine-grained soils to frost action.

5.4 The gradation of a soil is an indicator of engineering properties. Hydraulic conductivity, compressibility, and shear strength are related to the gradation of the soil. However, engineering behavior is dependent upon many factors, such as effective stress, mineral type, structure, plasticity, and geological origin, and cannot be based solely upon gradation.

5.5 Some types of soil require special treatment in order to correctly determine the particle sizes. For example, chemical cementing agents can bond clay particles together and should be treated in an effort to remove the cementing agents when possible. Hydrogen peroxide and moderate heat can digest organics. Hydrochloric acid can remove carbonates by washing and Dithionite-Citrate-Bicarbonate extraction can be used to remove iron oxides. Leaching with test water can be used to reduce salt concentration. All of these treatments, however, add significant time and effort when performing the sedimentation test and are allowable but outside the scope of this test method.

5.6 The size limits of the sedimentation test are from about 100 μ m to about 1 μ m. The length of time required to obtain a stable initial reading on the hydrometer controls the upper range of results, and the test duration controls the lower range.

5.7 The shape and density of the grains are important to the results. Stokes' Law is assumed to be valid for spherical particles even though fine silt- and clay-sized particles are more likely to be plate-shaped and have greater mineral densities than larger particles.

NOTE 5—The quality of the result produced by this standard is dependent on the competence of the personnel performing it, and the suitability of the equipment and facilities used. Agencies that meet the criteria of [Practice D3740](#) are generally considered capable of competent and objective testing/sampling/inspection/etc. Users of this standard are cautioned that compliance with [Practice D3740](#) does not in itself assure reliable results. Reliable results depend on many factors; [Practice D3740](#)

provides a means of evaluating some of those factors.

6. Apparatus

6.1 *Hydrometer*—ASTM hydrometer type 151H or 152H. These hydrometers shall conform to the requirements in Specification E100. See Annex A1.

6.2 *Sedimentation Cylinder*—At least two glass cylinders essentially having a height of about 457 mm, an inside diameter between 55 and 64 mm, and a capacity of 1,000 mL. The cylinders shall have an indication mark at $1,000 \pm 5$ mL. One cylinder is used for the soil suspension and the other one can be used as the control cylinder or the wash cylinder. The control cylinder shall have the same amount of dispersant as the soil suspension cylinder. See Annex A1.

6.3 *Separation Sieve*—No. 10 (2-mm) or finer sieve used to separate the reduced sample. This sieve is subjected to rough operation and shall not be used for quantitative grain size analysis.

6.4 *Thermometric Device*—A thermometric device capable of measuring the temperature range within which the test is being performed readable to 0.5°C or better and having an accuracy of at least $\pm 0.5^\circ\text{C}$. The thermometric device must be capable of being immersed in the suspension and reference solutions to a depth ranging between 25 and 80 mm. Full immersion, also known as complete or total immersion thermometers, shall not be used. The thermometric device shall be standardized by comparison to a nationally or internationally traceable thermometric device and shall include at least one temperature reading within the range of testing. The thermometric device shall be standardized at least once every twelve months. The same thermometric device shall be used for all measurements.

6.5 *Timing Device*—A clock, stopwatch, digital timer, or comparable device readable to one second or better.

6.6 *Balance*—Balances shall conform to the requirements of Specification D4753.

6.6.1 To determine the mass of the specimen, the balance shall have readability without estimation of 0.01 g. The capacity of this balance will need to exceed the mass of the container plus soil used to contain the soil suspension after the completion of the sedimentation test. In general, a balance with a minimum capacity of 1,800 g is sufficient.

6.7 *Drying Oven*—Vented, thermostatically controlled oven capable of maintaining a uniform temperature of $110 \pm 5^\circ\text{C}$ throughout the drying chamber. These requirements typically require the use of a forced-draft oven.

6.8 *Plate*—A clean, nonporous, smooth, solid surface that is large enough to pile and split about 500 g of material. The surface shall not be made of any type of paper product.

6.9 *Specimen-Mixing Container*—A 250-mL glass beaker or equivalent inert container with enough capacity to hold the specimen, the test water, and dispersant.

6.10 *Temperature Maintaining Device*—Unless otherwise specified by the requesting agency, the standard test temperature shall be in the range of $22 \pm 5^\circ\text{C}$. In addition, the temperature of the soil suspension shall not vary more than

$\pm 2^\circ\text{C}$. Normally, this temperature maintenance is accomplished by performing the test in a room with a relatively constant temperature. If such a room is not available, the cylinders shall be placed in an automatically temperature controlled insulated chamber or water bath that maintains a temperature within the tolerance specified above.

6.11 *Soil Suspension Oven-Drying Container*—A container having smooth walls and capable of holding approximately 1.5-L of the soil suspension. This container shall have a tight fitting lid or fit into a desiccator, to prevent moisture gain during cooling of the oven-dried specimen.

6.12 *Dispersion Apparatus*—Use one of the following devices to disperse the specimen; however for referee testing, the stirring apparatus shall be used.

6.12.1 *Stirring Apparatus (Referee)*—A mechanically operated stirring device in which a suitably mounted electric motor turns a vertical shaft at a minimum speed of 10,000 rpm without load. The shaft shall be equipped with a replaceable stirring paddle made of metal, as shown in Fig. 1. The shaft shall be of such length that the stirring paddle will operate between 19.0-mm and 37.5-mm above the bottom of the dispersion cup (Note 6).

NOTE 6—The SI units presented are basically soft conversions of the inch-pound units; other rationalized SI units should be acceptable providing they meet the requirements established by the inch-pound apparatus.

6.12.1.1 *Dispersion Cup*—A special dispersion cup conforming to either of the designs shown in Fig. 2 shall be provided to hold the sample while it is being dispersed. The cup shall contain two sets of three long baffle rods and two sets of three short baffle rods rigidly mounted to the interior sides of the cup. This cup is used with the stirring apparatus.

6.12.2 *Air Jet Dispersion Device (Optional)*—A tube type or other comparable device that uses compressed air to disperse the slurry (Note 7). The device requires an air source capable of providing up to $0.0024 \text{ m}^3/\text{s}$ of air to operate the device, such that pressures of 69 and 172 kPa can be achieved. The device shall be fitted with a pressure gauge on the line between the device and the air source. Water may condense in the lines when not in use and this water must be removed. There are two ways to remove the water: use of a water trap or purging the lines before use. If a water trap is used, it shall be installed on the air line in such a manner to prevent condensed water from entering the slurry. This device shall not be used in referee testing.

NOTE 7—Use of this device or others, causes differing amounts of dispersion and should be used with caution. Information on how to appropriately use this device should be obtained from the manufacturer. $0.0024 \text{ m}^3/\text{s}$ is equivalent to $5 \text{ ft}^3/\text{min}$. The device typically needs at least $0.0009 \text{ m}^3/\text{s}$ ($2 \text{ ft}^3/\text{min}$) to operate and therefore, some small air compressors are not capable of supplying sufficient air to operate the device.

6.13 *Agitator (Optional/Referee)*—A hand-held device to mix the soil suspension in the sedimentation cylinder prior to testing, as shown in Fig. 3. The agitator must not have any type of metal, such as a screw head, protruding from the bottom of the disk. To aid in strengthening the connection between the rod and the disk, a smaller disk (about 25 mm or less) having similar thickness and material as the larger disk, may be

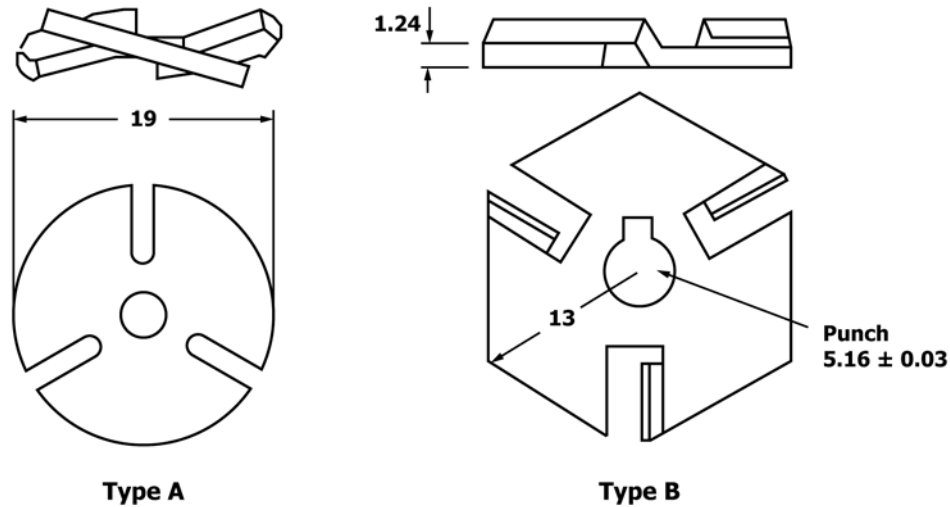

Dimensional Equivalents ^A		
mm		in.
19		0.75
13		0.51
5.16 ± 0.03		0.203 ± 0.001
1.24		0.049 (No. 18 BW Ga.)

Note: All dimensions are shown in millimetres unless otherwise noted.

^AThe SI units presented are basically soft conversions of the inch-pound units; other rationalized SI units should be acceptable providing they meet the technical requirements established by the inch-pound apparatus.

FIG. 1 Detail of Stirring Paddles

inserted on top of and in the center of the larger disk. This device shall be used for referee testing.

6.14 *Agitation of the Soil Slurry*—Any of the following items may be used to break up the soil aggregations as described in 11.1:

6.14.1 *Erlenmeyer Flask*—A glass flask having a capacity between 250-mL and 500-mL.

6.14.2 *Dispersion Shaker*—A platform, wrist action or similar type shaker having a gyratory, orbital, reciprocating, or similar motion to assist in the dispersion process by continuously agitating the soaking soil.

6.14.3 *Ultrasonic Water Bath*—The ultrasonic water bath must be large enough to hold a beaker or flask containing the soil slurry to be agitated for use in the sedimentation test. The water level in the bath should be equal to or higher than the water level in the specimen container.

6.15 *Desiccator (Optional)*—A desiccant containing device of suitable size used to prevent moisture gain during cooling of the oven-dried specimen.

6.16 *Mortar and Rubber-Covered Pestle (Optional)*—Apparatus suitable for breaking up aggregations of air-dried soil particles without breaking individual particles.

6.17 *Miscellaneous Items*—Items such as a wash/rinse bottle (squirt bottle), rubber scraper, spatula, and stirring rod may be useful.

7. Reagents and Materials

7.1 *Sodium Hexametaphosphate (NaPO₃)₆*—Also referred to as sodium metaphosphate is the dispersion agent (deflocculant) required to prevent the fine particles in suspension from

coalescing or flocculating (Note 8). Consult the Safety Data Sheet (SDS) for specific information regarding this chemical.

7.2 *Isopropyl Alcohol*—Also referred to as isopropanol alcohol or rubbing alcohol is used as a foam inhibitor. Commercially available in concentrations ranging from 70 % to 99 %.

7.3 *Test Water*—Distilled or demineralized water is the only permissible test fluid. The use of tap water is not permitted.

NOTE 8—Fine-grained soils requiring the use of a dispersant are those that do not readily slake in water, such as some highly plastic clays and most tropical soils. Typically, 5 grams per test of dispersant is used to prevent flocculation and is added directly to the soil, such that the concentration will equal 5 g/L in the final soil suspension volume. The chemical formula for the dispersant shown above is approximate.

8. Sampling

8.1 *General*—This test method does not address, in any detail, procurement of the sample. It is assumed the sample is obtained using appropriate methods and is representative of the material under evaluation. However, the testing agency shall preserve all samples in accordance with Practice D4220/D4220M, Group B, except if the as-received sample does not meet those requirements. In which case, the water content of the material does not have to be maintained.

8.2 Where data from this test are to be used for correlation with other laboratory or field test data, use the same material as used for these tests where possible and as much is practical.

8.3 The sample can be from a variety of sources and contain a wide range of particle sizes. Typically, samples for particle-size analysis are obtained from the following sources: large bags or buckets, small bags, jar samples, tube samples, or

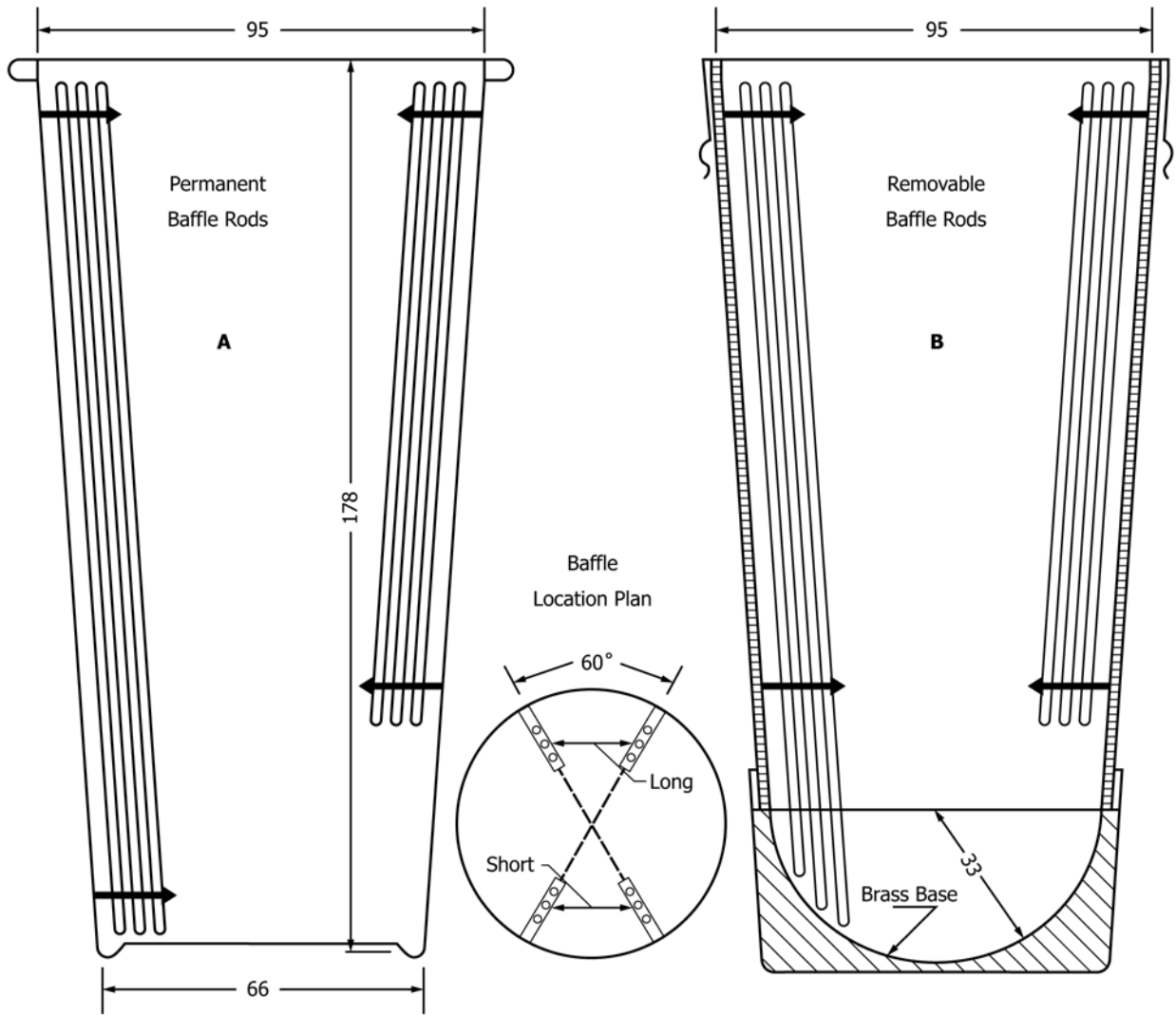

Dimensional Equivalents⁴

mm	in.
33	1.30
66	2.60
95	3.75
178	7.01

Note: All dimensions are shown in millimetres unless otherwise noted.

⁴The SI units presented are basically soft conversions of the inch-pound units; other rationalized SI units should be acceptable providing they meet the technical requirements established by the inch-pound apparatus.

FIG. 2 Dispersion Cup

specimens from other tests, such as consolidation, hydraulic conductivity or strength tests. In some cases, such as compaction testing, prior testing may have caused a reduction in particle sizes; therefore, it may be required to obtain a sample of the original material, the degraded sample, or both. Test Methods D6913, Section 9, gives additional information regarding sampling from the different sources.

8.3.1 Preserve the sample at its original moisture condition unless excluded above, and at no time shall the sample be allowed to undergo undesirable temperature changes such as freezing or heating.

8.4 When the sample contains particles larger than the 3/8-in. (9.5-mm) sieve, it shall be processed to obtain the reduced sample. If particle-size separation is necessary, process the sample to meet this requirement using the separation procedures provided in Test Methods D6913.

8.4.1 The reduced sample shall have a maximum particle size that passes through the 3/8-in. (9.5-mm) sieve.

8.4.2 The mass of the reduced sample shall meet or exceed the mass requirements given in Table 1.

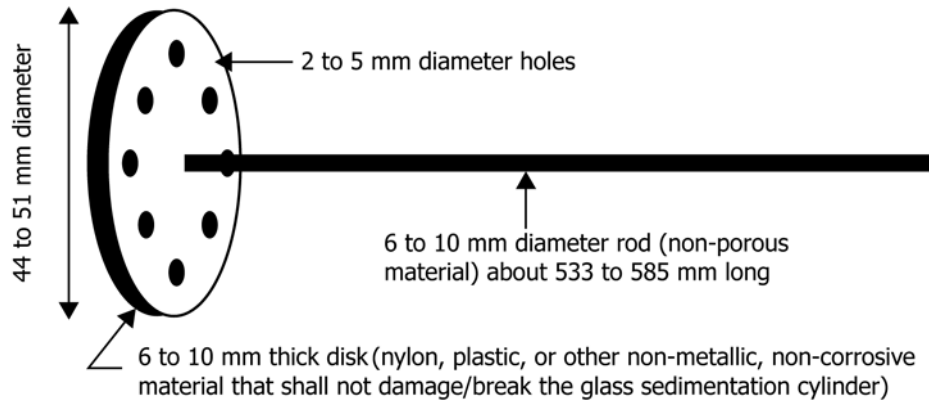

Dimensional Equivalents⁴

mm	in.
2 to 5	0.0781 to 0.200
6 to 10	0.250 to 0.375
533 to 585	22 ± 1
44 to 51	1.75 to 2.00

Note: All dimensions are shown in millimetres unless otherwise noted.

⁴The SI units presented are basically soft conversions of the inch-pound units; other rationalized SI units should be acceptable providing they meet the technical requirements established by the inch-pound apparatus.

FIG. 3 Detail of Agitator

8.4.3 Preserve the original moisture condition of the reduced sample, and at no time shall the reduced sample be allowed to undergo undesirable temperature changes such as freezing or heating.

9. Preparation of the Test Specimen

9.1 *Specimen Procurement*—This standard presents two preparation methods to obtain the sedimentation specimen from the reduced sample: moist and air-dried. In these preparation methods, moist and air-dried refers to the condition of the material or sample as it is being reduced to an appropriate particle size and mass. The test shall not be performed on oven-dried material. The moist preparation method shall be used for referee testing and for samples not received in the air-dried state. The air-dried method shall only be used on materials received in the air-dried state (Note 9). Since some fine-grained, air-dried soils aggregate, a mortar and rubber covered pestle is used to break up aggregations. Care must be taken to avoid disintegration or reduction of individual particles. Use only enough force as necessary to break up the aggregations without destroying the individual particles. Additional guidance for splitting material to obtain a representative specimen using a splitter, quartering, or moist stockpile sampling is given in Test Methods D6913, Annex A2.

NOTE 9—Air drying causes irreversible changes to the clay particles that cause permanent flocculations and decreases the fine fraction.³

9.2 *Moist Preparation (Referee)*—This preparation method shall be used for materials not received in the air-dried state. This method is especially important for any soil whose properties are altered due to drying such as, most organic soils,

many highly plastic fine-grained soils, tropical soils and soils containing halloysite. The material is thoroughly mixed to obtain a uniform reduced sample. Intact fine-grained samples should be chopped/reduced into small pieces, less than approximately 13 mm, and mixed to make uniform. Test water can be added to assist in making a uniform sample. There is no need to process the fine-grained materials through a sieve.

9.3 *Air-Dried Preparation*—This preparation method shall only be used if the sample is received in the dried condition. In order to obtain a uniform reduced sample, the sample is blended at room temperature.

9.4 If the reduced sample contains particles which are larger than the No. 10 (2.0-mm) sieve, the material shall be separated using a No. 10 (2.0-mm) or finer sieve. Process the entire reduced sample over the No. 10 (2.0-mm) or finer sieve using a rubber scraper and, if needed, test water to aid in working the material through the sieve. Check that the material retained on the sieve does not contain aggregations of finer particles. Any aggregations should be broken and passed through the sieve. It is not necessary that the separation be totally complete but the material passing the sieve shall be representative. The material passing the separation sieve is termed the sedimentation sample and shall meet the minimum mass requirement of Table 1. Record the separation sieve size that is used to separate the sample.

9.5 Estimate the amount of moist mass needed for the sedimentation test using the equation (Note 10):

$$M_{mest} = H_c \times \left(\frac{100}{\%est} \right) \times \left(1 + \left(\frac{w_{cest}}{100} \right) \right) \quad (1)$$

where:

M_{mest} = estimated moist mass, nearest 1 g,

³ Sridharan, A., Jose, B.T., and Abraham, B.M., Technical Note on "Determination of Clay Size Fraction of Marine Clays," *Geotechnical Testing Journal*, GTJODJ, Vol. 14, No. 1, March 1991, pp. 103-107.

- H_c = hydrometer capacity, g (either 45 for 151H or 55 for 152H),
- $\%_{est}$ = estimated percentage of material passing the No. 200 (75- μ m) sieve, nearest 1 %, and
- w_{cest} = estimated water content, nearest 1 %.

NOTE 10—The mass of the sedimentation test specimen should be selected based on the amount of material that will be in suspension at the time of the first reading. The capacity of the 152H hydrometer is about 55 g of dry soil and the capacity of the 151H is about 45 g. The wet mass should be adjusted to account for the water content and the fraction of particles larger than the No. 200 (75- μ m) sieve. For example, if the water content is estimated at 20 %, using a 151H hydrometer, and an estimated percent passing the No. 200 (75- μ m) sieve of 95 %, the estimated moist mass needed is 57 g.

9.6 If the sedimentation sample contains sufficient material, then split or quarter the sedimentation sample into at least two portions: one for the water content determination and one for the sedimentation test. The water content specimen shall contain 50 ± 10 g of material.

9.7 If the sedimentation sample has limited material, reduce the mass to obtain the sedimentation specimen. Do not obtain a water content specimen. Obtain the dry mass, M_d , of the sedimentation specimen at the end of the test as discussed in 11.12 and calculated in 12.1.2.

NOTE 11—If there is enough material after splitting/quartering to obtain the necessary masses for both the sedimentation and water content specimens, the sedimentation sample is considered to have sufficient material. If there is not enough material to obtain both the necessary masses of the specimens, the sedimentation sample is considered to have limited material.

9.8 Record the mass of the moist soil, M_m , used for the sedimentation test to the nearest 0.01 g.

9.9 Place the sedimentation specimen in the specimen-mixing container and record the identification of the specimen-mixing container.

9.10 If sufficient material is available, immediately use the other specimen for determination of the water content in accordance with Test Methods D2216, and record the water content, w_c , to the nearest 0.1 %.

10. Verification/Preparation of Apparatus

10.1 *Hydrometer*—Check and record the dimensions of the 151H or 152H hydrometers as presented in Annex A1 in accordance with the interval listed in the Annex. The hydrometer shall be free of cracks and chips, which can compromise the integrity of the hydrometer. The body and stem of a hydrometer seldom change over time, unless they have been subjected to corrosive materials or have been damaged, that is, chipped or cracked. They only need to be checked before use or after damage has been suspected or seen. Since it is possible for the paper scale inside the hydrometer stem to slide down, the length of the stem above and below the top and bottom graduations, respectively, as well as the hydrometer reading in the test water, shall be checked and documented according to the interval presented in Annex A1 to make sure the scale has remained in its proper place. If the scale has moved, the hydrometer shall be replaced.

10.1.1 *Hydrometer Readings*—Hydrometer readings are taken to the nearest $\frac{1}{4}$ division (Note 12). Reading the

hydrometer can be difficult. A properly placed hydrometer should neither bob nor rotate appreciably when released in the soil suspension. It is important for the stem to be dry and clean when inserting it into the soil suspension. If the stem is wet above the reading point it will add mass to the hydrometer causing the reading to be too low. If the stem is not clean, variations in the meniscus rise will result. In this application, the hydrometers are always read at the top of the meniscus for the reason stated in 10.3.

NOTE 12—Reading the 152H hydrometer to the nearest $\frac{1}{4}$ division during the first 5 to 8 minutes of the test can be difficult. During that time it is acceptable to read the 152H hydrometer to the nearest $\frac{1}{2}$ division.

10.1.2 To insert the hydrometer correctly do the following: First, make sure the stem is dry. Then, gently hold it by the stem with one or both hands and slowly lower it to the depth at which it just floats. This insertion process should take between 5 to 15 seconds.

10.2 *Temperature-Density Correction*—During a test, the suspension fluid density changes, therefore calculations for the quantity of particles in suspension must account for fluid density changes due to temperature, presence of dispersant and the meniscus rise. The temperature-density correction is shifting the hydrometer scale, which is factory set for distilled water at 20°C. There are two ways to determine this correction: take companion measurements in a control cylinder filled with the reference solution during the testing or generate a reusable, calibration relationship. Both options require the use of a reference solution composed of test water and the same amount of dispersant used in the sedimentation test cylinder. The meniscus correction is automatically accounted for in the temperature-density correction for both options by consistently reading the hydrometer at the top of the meniscus as described in 10.3.

10.2.1 *Reference Solution*—The reference solution shall be prepared with the same amount of dispersant as the soil suspension. Fill a control cylinder to the 1,000 mL mark with a mixture of test water and the same amount of dispersant used in the soil suspension cylinder. The test water and dispersant shall be well mixed such that no visible crystals can be seen and the reference solution shall be agitated to make sure the dispersant is adequately mixed throughout the control cylinder.

10.2.1.1 *Companion Measurements*—Use a control cylinder filled with the reference solution in conjunction with the soil suspension cylinder to obtain the correction. Position the control cylinder in the same temperature controlled location as the test cylinders so that all cylinders are at or near the same temperature. For each hydrometer and temperature reading taken in the soil suspension cylinder, take a corresponding hydrometer reading and temperature reading in the control cylinder. However, it is permissible for one control cylinder hydrometer reading taken at the start of the sedimentation test to be used for the initial series of time readings in the soil suspension up to 30 minutes. It is also permissible for one control cylinder temperature reading taken at the start of the sedimentation test to be used for the initial series of time readings in the soil suspension up to the first 30 minutes if the temperature changes in the soil suspension cylinder vary less than 0.5°C between each temperature reading. Record the

elapsed time and the hydrometer and temperature readings of the control cylinder on the data sheet(s) only when measured (Note 13).

NOTE 13—Readings taken in one control cylinder may be used for multiple test cylinders. Therefore, if the hydrometer and temperature readings in the control cylinder are only taken once during the first 30 minutes of the test, only that reading is recorded on each of the data sheet(s) to which it applies. These measured readings are not to be written in for the other times during the first 30 minutes when a measurement was not actually determined.

10.2.2 *Calibration Relationship*—This option generates a general calibration relationship between the hydrometer reading of a control cylinder filled with the reference solution and the temperature, which eliminates the need for companion measurements during the test. A temperature-based general calibration relationship is required and established for each hydrometer. A sedimentation cylinder is filled to the 1,000 mL mark with test water with the same amount of dispersant used in the soil suspension. Be sure the solution is thoroughly mixed and the temperature is allowed to equilibrate. Then insert the hydrometer as described in 10.1.2. Take the reading at the top of the meniscus and record this reading and the temperature of the solution. Rinse the hydrometer well with test water between readings and dry it prior to taking the next reading. Increase/Decrease the temperature of the cylinder, allow it to come to temperature equilibrium and repeat the measurement process. Take at least five different hydrometer and temperature readings within the range of temperatures expected during the sedimentation test. Calculate the constant A or B as discussed below.

10.2.2.1 The 151H hydrometer measures the specific gravity of the fluid relative to distilled water at 20°C. The calibration measurements are used to compute the constant A in the following equation. The standard deviation of the five measurements shall be less than 0.0005. The average value of A is used when computing the temperature-density correction.

$$A = R_{151,t} + (7.784 \times 10^{-6} \times T_t) + (4.959 \times 10^{-6} \times T_t^2) \quad (2)$$

where:

- A = average specific gravity shift (151H hydrometer), nearest 0.0001,
- $R_{151,t}$ = 151H specific gravity hydrometer at reading, t , in reference solution, readable to 0.00025 or better,
- T = temperature at reading, t , readable to 0.5°C or better, and
- t = subscript indicating the reading number during calibration.

10.2.2.2 The 152H hydrometer measures the mass of particles (specific gravity of 2.65) in a suspension of distilled water at 20°C. The temperature-density correction provides the offset mass reading for the hydrometer for a specific temperature and dispersant concentration. The calibration measurements are used to compute the constant B in the following equation. The standard deviation of the 5 measurements shall be less than 0.5 g/L. The average value of B is used when computing the temperature-density correction.

$$B = R_{152,t} + (1.248 \times 10^{-2} \times T_t) + (7.950 \times 10^{-3} \times T_t^2) \quad (3)$$

where:

- B = average mass reading shift (152H hydrometer), nearest 0.1,
- $R_{152,t}$ = mass in reference solution hydrometer at reading, t , readable to 0.25 g/L or better,
- T = temperature at reading, t , readable to 0.5°C or better, and
- t = subscript indicating the reading number during calibration.

NOTE 14—The equations relating the hydrometer readings to temperature are based on the same water density-temperature expression as used in Test Methods D854. For the 151H specific gravity hydrometer, the constants in the water density-temperature equation from Test Methods D854 are divided by the density of water at 20°C (0.99821 g/mL). For the 152H mass in suspension hydrometer, the constants are multiplied by 1606 setting the scale to read mass of solids in solution for a particle specific gravity of 2.65.

10.3 *Meniscus Correction*—Hydrometers are designed to be read at the fluid surface, however, the fluid is wetting to the glass such that the soil suspension will rise up the hydrometer making a reading at the fluid surface impossible at times. It is common practice to read the hydrometer at the top of the meniscus and it must be taken there even when it is possible to see through the soil suspension. The meniscus rise has a small impact on the effective depth determination since the reading is taken slightly above the surface of the suspension. This rise causes a change to the third significant digit in the computed particle size. The meniscus correction is performed before initial use of the hydrometer and after damage has been suspected or noticed.

10.3.1 The meniscus correction, C_m , as shown in Fig. 4, is determined by inserting the hydrometer with a clean and dry stem and without bobbing into the test water with the proper amount of dispersant. The reading at the top of the meniscus and the reading where the plane of water surface intersects the stem are recorded. The difference between these two readings is the meniscus correction, C_m . In accordance with Test Method E126, the latter reading shall be obtained using the following guidance. Observe a point slightly below the plane of the water surface and raise the line of vision until this surface, seen in an ellipse, becomes a straight line. The point where this line cuts the hydrometer scale is the hydrometer reading. Holding a white card behind the cylinder just below the water level will improve the visibility of the surface. The

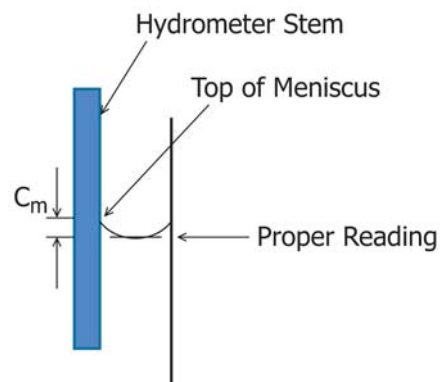

FIG. 4 Meniscus Correction Diagram

hydrometer readings shall be recorded to the nearest ¼ division. The meniscus correction is a positive number for either hydrometer used.

10.4 *Effective Depth*—The effective depth, also referred to as “true depth,” is used in the calculation of the particle fall distance for each reading. The effective depth is defined as the center of (volume) buoyancy of the hydrometer to the surface of the soil suspension. The equation to calculate the effective depth when the hydrometer is inserted and removed between readings requires certain dimensional measurements in order to do the calculation. Refer to Fig. 5.

10.4.1 Determine and record the volume of the hydrometer bulb, V_{hb} , to the nearest 1 cm³ using the procedure given in Annex A1.3.4. The bulb includes everything from the bottom tip up to the base of the stem.

10.4.2 Determine and mark the center of (volume) buoyancy, c_b , using the procedure given in A1.3.5.

10.4.3 Measure the distance between the center of (volume) buoyancy, c_b , and the maximum hydrometer reading H_{r2} , as well as the minimum hydrometer reading, H_{r1} . Record both values to the nearest 0.1 cm. Refer to Fig. 5.

10.4.4 Measure and record the inside cross-sectional area of the sedimentation cylinder, A_c , to the nearest 0.1 cm² using the procedure given in A1.4.2.1.

10.5 *Sedimentation Cylinder*—Check and record the dimensions of the sedimentation cylinders as presented in Annex A1 in accordance with the interval presented in Annex A1.

10.6 *Sieves*—See Practice E11 for the verification requirements of the sieves used in this test method.

10.7 *Miscellaneous*—The ancillary equipment used in conjunction with these test methods shall be calibrated/verified/checked according the intervals listed in Practice D3740 and performed in accordance with their applicable standards.

11. Procedure

11.1 Add 5.0 ± 0.1 g of sodium hexametaphosphate to the sedimentation specimen in the specimen-mixing container obtained in 9.9 or dissolve this amount of dispersant in 100 mL of test water and add it to the sedimentation specimen. Record to the nearest 0.01 g the actual amount of dispersant, M_{disp} , placed in the container or dissolved in the test water. If added directly to the sedimentation specimen, add at least 100 mL of test water to the specimen and dispersant to form a slurry of milkshake consistency. The amount of test water to be added during this step should be sufficient enough only to facilitate the process of breaking apart the soil aggregations. Mix the contents with a spatula or similar device until all of the soil aggregations are broken-up (Note 15).

NOTE 15—If hand mixing is not efficient, use a 250 to 500 mL Erlenmeyer flask along with either a wrist or orbital dispersion (mechanical) shaker to vigorously agitate the soil slurry in a minimum of 150 mL of test water for a few hours or until all the soil aggregations are broken-up. Be aware the dispersion cup has a capacity of about 400 mL and the stirring apparatus is only efficient in dispersing soil aggregations that will pass between the baffle rods. An ultrasonic water bath, along with the flask, may also be used to agitate the slurry.

11.2 Prior to the overnight conditioning period, disperse the slurry using either the stirring apparatus or an air jet device.

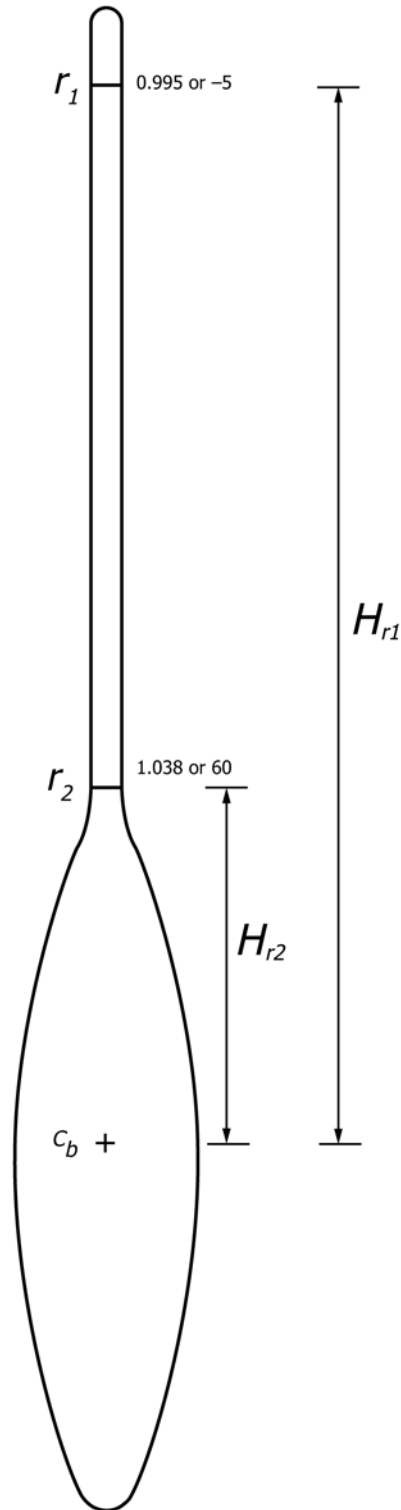

FIG. 5 Effective Depth Dimensional Measurements

11.2.1 If using the stirring apparatus, transfer the slurry to the dispersion cup. Use a wash/rinse bottle filled with test water to aid in the transfer and make sure all of the slurry has been transferred to the dispersion cup. Add additional test water as necessary such that the cup is half full, then use the stirring apparatus to blend the soil for about 1 minute.

11.2.1.1 Transfer all the dispersed slurry into the sedimentation cylinder. Use the wash/rinse bottle filled with test water as needed to make sure all of the slurry is transferred to the cylinder. Add test water to the sedimentation cylinder to bring the bottom of the meniscus of the slurry to the 1,000 mL \pm 1 mm mark. Proceed to 11.3.

11.2.2 If using the tube type air jet device, transfer the slurry to the sedimentation cylinder. Use a wash/rinse bottle filled with test water to aid in the transfer and make sure all of the slurry has been transferred to the cylinder. Add additional test water as necessary to bring the volume to no more than 250 mL in the sedimentation cylinder.

11.2.2.1 Before placing the device into the cylinder, slowly allow air to flow until the gauge reads 7 kPa. This initial pressure is needed to prevent the slurry from entering the air jets when the device is inserted into the cylinder and to remove any water that has condensed in the lines. Then, slowly lower the device into the slurry. Make sure the rubber stopper is securely in place at the top of the cylinder to prevent the slurry from being ejected from the cylinder.

11.2.2.2 For clayey soils increase the pressure to 172 kPa and for sandy soils increase the pressure to 69 kPa. Once the pressure is reached, disperse the slurry for five minutes. At the end of five minutes, reduce the pressure to 7 kPa and lift the air jets out of the slurry and wash any slurry remaining on the device back into the cylinder. Once the device is washed off, turn off the air flow to the device and add test water to the sedimentation cylinder to bring the bottom of the meniscus of the slurry to the 1,000 mL \pm 1 mm mark. Proceed to 11.3.

11.3 Mix the slurry using the agitator (referee) or the tipping method (Note 16). The agitator device is the preferred/referee method for mixing. Check for the presence of foam on top of the slurry after mixing. If a significant amount of foam is present, it may be necessary to reduce the foam using isopropyl alcohol just prior to the start of testing (See 11.7.1).

11.3.1 To use the agitator, insert the paddle to the lower $\frac{1}{4}$ of the cylinder. Stroke the agitator at a rate of about one cycle per second over a distance of several centimeters to dislodge any material stuck to the bottom of the cylinder. After the material is dislodged, the agitator should be rapidly moved downwards until the paddle almost comes into contact with the bottom of the cylinder and then upwards with a slower motion. The downward stroke should take about one to two seconds while the upward stroke should take about two to three seconds. As this process is repeated, the elevation of the starting position of the agitation cycle is raised until the bottom of the agitator is significantly above the mid-height of the soil suspension. Keep the paddle submerged at all times during mixing. Mix for about one minute or until the suspension appears uniform.

11.3.2 To use the tipping method, first place a rubber stopper in the open end of the cylinder or use the palm of the hand to cover the opening. Then turn the cylinder upside down and back for a period of one minute to complete the agitation of the slurry (Note 17). Using the cylinder tipping method is not very efficient and tipping for more than one minute will typically be required when testing highly plastic clays. This

method of agitation may leave some soil aggregations. Use of the agitator is greatly encouraged.

NOTE 16—When using the tipping method, there will likely be some soil particles remaining on the rubber stopper or hand and on the sides of the sedimentation cylinder above the 1,000 mL mark. Be careful not to lose much material by scraping the material adhering to the rubber stopper or hand off onto the rim of the cylinder. Do not rinse these particles back into the cylinder. The minor loss of mass (\sim 0.02 g or less, if care is taken) is less critical with respect to the calculations than the addition of water (\sim 5 mL) to the cylinder.

NOTE 17—The number of turns during this minute should be approximately 60 counting the turn upside down and back as two turns. Any soil remaining in the bottom of the cylinder during the first few turns should be loosened by vigorously shaking of the cylinder while it is inverted.

11.4 If using a companion measurement to obtain the temperature-density correction, prepare the reference solution in a control cylinder by dissolving the same amount (5.0 ± 0.1 g) of sodium hexametaphosphate as used in the soil suspension cylinder in test water. Add test water to the sedimentation cylinder to bring the bottom of the meniscus of the solution to the 1,000 mL \pm 1 mm mark.

11.5 Cover the cylinder(s) to prevent evaporation and allow the cylinder(s) to sit overnight either in a temperature controlled insulated chamber or water bath or in an area of relatively constant temperature. This conditioning period allows the temperature to equilibrate and for the specimen to deflocculate (Note 18). The soil slurry is now referred to as a soil suspension since the specimen is basically ready for testing.

11.6 At the end of the conditioning period, check the suspension for indications of flocculation (Note 19). If the suspension has indications of flocculation, then the test is invalid and the suspension should be discarded since it has been contaminated with dispersant. A new specimen would need to be treated to prevent flocculation. Such treatment is beyond the scope of this test method.

NOTE 18—Strong interparticle bonding can occur in suspension having high salt concentrations. The dispersant will not be effective in breaking these bonds. In such circumstances the salt should be leached from the soil before proceeding with the sedimentation test. This leaching results in a considerable increase in effort and difficulty to process the material and is not discussed in this standard.

NOTE 19—Flocculation of clay particles can be difficult to detect. Minor flocculation will shift the particle-size distribution (gradation) towards a finer fraction. Moderate flocculation will cause a plateau in the curve as the sedimentation process stops. Major flocculation will completely halt sedimentation at an early stage. Only major flocculation is visually detectable showing a lack of material collected at the bottom of the cylinder, a surface layer of clear fluid, or horizontal cracks in the suspension.

11.7 Once the suspension has temperature equilibrated and deflocculated, the suspension shall once again be mixed to create a uniform suspension. Repeat the mixing procedure as described in 11.3. Upon completion of agitation, make sure the cylinder is on a stable surface and in a location where it will not be subjected to any jarring or disturbance and immediately start the timer as directed in either 11.7.2 or 11.7.3. If using a temperature controlled water bath, immediately place the cylinder back into the water bath after agitation.

11.7.1 If significant foam develops on top of the suspension after mixing, immediately add up to three drops of isopropyl alcohol to the suspension to reduce or eliminate the foam.

11.7.2 If using the agitator, start the timer when the paddle of the agitator breaks the surface of the soil suspension. After removing the agitator allow the “free” liquid on it to drain back into the sedimentation cylinder.

11.7.3 If using the tilting method, start the timer after completion of the last inversion.

11.8 Hydrometer readings shall be taken at elapsed times of approximately, 1, 2, 4, 15, 30, 60, 240, and 1440 minutes. Additional readings can be taken to better define the particle-size distribution (gradation) relationship.

11.8.1 About 15 to 20 seconds before a reading is required, gently place the hydrometer into the sedimentation cylinder to a depth approximately equal to the level at which it will float as described in 10.1.2. At the prescribed elapsed times and when the hydrometer is stable, read and record the hydrometer reading, r_m , to the nearest $\frac{1}{4}$ division, and record the elapsed time, t_m .

11.8.2 When removing the hydrometer from the suspension, the removal process should take about 5 to 10 seconds and be with a steady motion. Generally there will be a drop of suspension at the tip of the hydrometer. Touch the tip to the inside lip of the cylinder and allow the drop to flow back into the cylinder.

11.8.3 With a spinning motion, place the hydrometer into a wash cylinder filled with test water to clean off the hydrometer (Note 20). Once the hydrometer is clean, remove and dry it off prior to the next reading or the reading in the control cylinder if using companion measurements.

NOTE 20—While it is ideal to rinse the hydrometer off in a wash cylinder that can be easily cleaned, it is permissible to rinse the hydrometer in another suitable container filled with test water providing there is ample room for the hydrometer to spin.

11.9 Immediately after taking a hydrometer reading, gently insert the thermometric device into the soil suspension and record the temperature, T_m , to the nearest 0.5°C or better. Do not allow the thermometric device to create disturbance in the suspension. After removing the thermometric device, cover the cylinder to prevent evaporation when the time between the readings exceeds five minutes.

11.9.1 The temperature reading taken at the start of the sedimentation test may be used for the initial series of time readings up to 30 minutes. The temperature does not need to be measured more frequently than 30 minutes and shall be recorded at the elapsed times of actual measurements.

11.10 When using a companion measurement to determine the temperature-density correction, the hydrometer, $r_{d,m}$, and temperature, T_m , readings of the control cylinder shall be measured and recorded in accordance with 10.2.1.1.

11.11 If the dry mass, M_d , of the sedimentation specimen has been or will be determined from a companion specimen, the soil suspension is now ready to be washed over the No. 200 (75- μm) sieve.

11.11.1 Pour the soil suspension over the No. 200 (75- μm) sieve. Take care in transferring the soil suspension from the

cylinder to the wash sieve so as not to lose material. Make sure there is no remaining material in the cylinder and that the wash water is running clear before transferring the material retained on the sieve into the oven drying container. Record the identification of the container and proceed to 11.13.

11.12 If the dry mass, M_d , of the sedimentation specimen was not determined using the water content taken in 9.10, then the dry mass is obtained from the soil suspension used for the sedimentation test.

11.12.1 After the last hydrometer reading is obtained, transfer all of the soil suspension to the oven drying container as described in 6.11. To facilitate the complete removal of all of the suspension, agitate the cylinder to distribute the soil as described in 11.3 (Note 21). Pour the agitated suspension into the container and record the identification of the container. If using the container as the tare to calculate the dry mass, also record the mass of the container prior to adding the suspension to the nearest 0.01 g. Use a wash/rinse bottle to aid in transferring the slurry.

NOTE 21—It is not necessary to duplicate the exact requirements of 11.3 in order to sufficiently distribute the soil. Use only as many turns (tipping method) or strokes (agitator method) as needed to dislodge the material from the bottom of the cylinder. The purpose of this agitation is to reduce the amount of additional water needed to remove all of the suspension from the cylinder. Additional test water may be added to thoroughly clean the cylinder and remove all of the suspension.

11.12.2 Dry the suspension to a constant mass in the drying oven at $110 \pm 5^\circ\text{C}$. Usually constant mass is achieved after 24 hours when forced-draft type ovens are used. If there is any uncertainty if the specimen has thoroughly dried, it is necessary to perform the constant mass test after an additional six hours in the drying oven, to verify it has indeed completely dried before proceeding (Note 22).

NOTE 22—Determining the dry mass after the test adds additional time and consideration. Because the oven must remove large amounts of water, the drying time takes longer and the constant mass check interval is extended. The large surface area of the specimen in the container allows the material to potentially absorb more moisture from the air as it cools.

11.12.3 Remove the container from the drying oven and allow it to cool in a desiccator or a tightly covered/sealed container. After the container has cooled, determine and record the dry mass of the soil plus dispersant, M_{dd} , to the nearest 0.01 g.

11.12.4 After recording the dry mass of soil plus dispersant, M_{dd} , cover the specimen with tap water and allow the specimen to soak. During soaking, gently stir the specimen to facilitate the separation of particles. Pour the soaked material over the No. 200 (75- μm) sieve. Take care in transferring the soil suspension from the container to the wash sieve so as not to lose material. Make sure there is no remaining material in the container and that the wash water is running clear before transferring the material retained on the sieve into the oven drying container. Record the identification of the container if a different container is used and proceed to 11.13.

NOTE 23—Test Methods D1140 provides information on the washing technique to use.

11.13 Dry the retained material to a constant mass in the drying oven at $110 \pm 5^\circ\text{C}$. Usually constant mass is achieved

overnight (~12-16 hours) when forced-draft type ovens are used. If there is any uncertainty if the specimen has thoroughly dried, perform the constant mass test after an additional two hours in the drying oven, to verify it has indeed completely dried before proceeding.

11.14 Remove the container from the drying oven and allow it to cool in a desiccator or cover the container with a tight fitting lid. After the container has cooled, determine and record the dry mass of the soil retained on the No. 200 (75- μ m) sieve, M_{dr} , to the nearest 0.01g. During the washing process, the dispersant has been removed and the resulting dry mass will only include the particles retained on the sieve.

12. Calculations

12.1 Calculate the dry mass, M_d , of the sedimentation specimen using either of the following methods.

12.1.1 *Dry Mass Using Moist Mass and Water Content*—Using the water content, w_c , of the companion specimen determined in 9.6 and the initial moist mass, M_m , of the sedimentation specimen, calculate the dry mass of the sedimentation specimen based as follows:

$$M_d = \frac{M_m}{1 + \left(\frac{w_c}{100}\right)} \quad (4)$$

where:

M_d = mass of dry soil, nearest 0.01 g,
 M_m = mass of moist soil, nearest 0.01 g, and
 w_c = water content, nearest 0.1 %.

12.1.2 *Dry Mass Using The Sedimentation Specimen*—Calculate the dry mass, M_d , of the sedimentation specimen based on the oven-dried material as obtained in 11.12 using the following equation:

$$M_d = M_{dd} - M_{disp} \quad (5)$$

where:

M_d = mass of dry soil, nearest 0.01 g,
 M_{dd} = mass of dry soil plus dispersant, nearest 0.01 g, and
 M_{disp} = mass of dispersant, nearest 0.01 g.

12.2 *Temperature-Density Correction: Calibration Relationships*—When using the calibration relationship to determine the hydrometer offset reading, $r_{rd,m}$, calculate the corrected hydrometer reading using the equation below that corresponds to the hydrometer used during the test.

12.2.1 For the 151H hydrometer, compute the offset reading for each sedimentation test reading using the following equation:

$$r_{d,m} = A - 7.784 \times 10^{-6} \times T_m - 4.959 \times 10^{-6} \times T_m^2 \quad (6)$$

where:

$r_{d,m}$ = 151H specific gravity hydrometer offset at reading, m , nearest 0.0001 (dimensionless),
 A = average specific gravity shift (151H hydrometer), nearest 0.0001 (dimensionless),
 T = temperature at reading, m , readable to 0.5°C or better, and
 m = subscript indicating the reading number during the sedimentation test.

12.2.2 For the 152H hydrometer, compute the offset reading value for each sedimentation test reading using the following equation:

$$r_{d,m} = B - 1.248 \times 10^{-2} \times T_m - 7.950 \times 10^{-3} \times T_m^2 \quad (7)$$

where:

$r_{d,m}$ = 152H g/L hydrometer offset at reading, m , nearest 0.1 g/L,
 B = average mass shift (152H hydrometer), nearest 0.1 g/L,
 T = temperature at reading, m , readable to 0.5°C or better, and
 m = subscript indicating the reading number during the sedimentation test.

12.3 *Temperature-Density Correction: Companion Measurement*—When using the companion measurement to obtain the temperature-density correction, use the recorded hydrometer offset reading taken in the control cylinder, $r_{d,m}$, that corresponds to the hydrometer used during the test.

12.4 *Mass Percent Finer*—For each hydrometer reading taken in the soil suspension, compute the mass of material still in suspension as a percentage of the sedimentation specimen using the appropriate equation for the type of hydrometer used during the test.

12.4.1 For each 151H hydrometer reading, calculate and record the mass percent finer using the following equation:

$$N_m = \left(\frac{G_s}{G_s - 1}\right) \left(\frac{V_{sp}}{M_d}\right) \rho_c (r_m - r_{d,m}) \times 100 \quad (8)$$

where:

N_m = mass percent finer material at reading m , nearest 1 %,
 V_{sp} = volume of suspension, nearest 0.1 cm³,
 ρ_c = mass density of water at the temperature of manufacturer calibrated, g/cm³ (Note 24),
 M_d = dry soil mass of the sedimentation specimen, nearest 0.01 g,
 G_s = specific gravity of soil, nearest three significant digits, (dimensionless),
 r_m = hydrometer reading in suspension at reading m , readable to 0.00025 (dimensionless),
 $r_{d,m}$ = hydrometer offset reading from reference solution at same temperature as reading m , nearest 0.0001 (dimensionless), and
 m = subscript indicating the reading number during the sedimentation test.

NOTE 24—The mass density of water at the time of calibration is dependent upon the temperature at time of calibration. H151 and H152 hydrometers are calibrated to 20°C, which gives a mass density of 0.98821 g/cm³.

12.4.2 *Mass Percent Finer*—For each 152H hydrometer reading, calculate and record the mass percent finer using the following equation:

$$N_m = 0.6226 \times \left(\frac{G_s}{G_s - 1}\right) \times \left(\frac{V_{sp}}{M_d}\right) (r_m - r_{d,m}) \times \left(\frac{100}{1000}\right) \quad (9)$$

where:

0.6226 = correction factor to adjust for particle specific gravity,

r_m = hydrometer reading in suspension at reading m , readable to 0.25 g/L, and
 $r_{d,m}$ = hydrometer offset reading from reference solution at same temperature as reading m , nearest 0.1 g/L.

12.5 Effective Depth—This value is used in the calculation of the particle fall distance for each hydrometer reading. The following equation is used to calculate the travel distance of the particles when the hydrometer is inserted immediately before a reading and is removed until the next reading.

$$H_m = H_{r_2} + \left(\frac{H_{r_1} - H_{r_2}}{r_2 - r_1} \right) \times (r_2 - r_m + C_m) - \left(\frac{V_{hb}}{2A_c} \right) \quad (10)$$

where:

H_m = distance particles fall at reading m when the hydrometer is inserted only for an individual reading, 2 significant digits, cm,
 V_{hb} = volume of the hydrometer bulb up to the base of the stem, nearest 1 cm³,
 A_c = cross-sectional area of the sedimentation cylinder, nearest 0.1 cm²,
 H_r = distance between the center of (volume) buoyancy and the minimum (H_{r_2}) and maximum (H_{r_1}) hydrometer readings nearest 0.1 cm,
 r_m = hydrometer reading in suspension at reading m , 151H: readable to 0.00025 (dimensionless) 152H: readable to 0.25 g/L,
 C_m = meniscus correction: 151H nearest 0.25 division (dimensionless) 152H: nearest 0.25 g/L,
 r = the minimum (r_2) and maximum (r_1) hydrometer reading (dimensionless or g/L), and
 m = subscript indicating the reading number during the sedimentation test.

12.6 Maximum Particle Diameter in Suspension—For each hydrometer reading, calculate and record the particle diameter of the soil using the following equation:

$$D_m = \left(\sqrt{\frac{18\mu}{\rho_w g (G_s - 1)} \cdot \frac{H_m}{t_m}} \right) \times 10 \quad (11)$$

where:

D_m = particle diameter, two significant digits, mm,
 μ = viscosity of water at 20°C, 0.0100 g/cm-s,
 ρ_w = mass density of water at 20°C, 0.99821 g/cm³,
 g = acceleration due to gravity, 980.7 cm/s²,
 G_s = specific gravity of soil, three significant digits (dimensionless),
 t_m = elapsed (fall) time, two significant digits, s,
 H_m = particle fall distance, two significant digits, cm, and
 m = subscript indicating the reading number during the sedimentation test.

12.7 Percent Passing the No. 200 (75- μ m)—Calculate the percent passing the No. 200 (75- μ m) sieve using the following equation:

$$P_p = 100 \left(1 - \frac{M_{dr}}{M_d} \right) \quad (12)$$

where:

P_p = percent passing the No. 200 (75- μ m) sieve, nearest 0.1 %,
 M_d = initial dry mass of the sedimentation specimen without dispersant, nearest 0.01 g, and
 M_{dr} = dry mass retained on the No. 200 (75- μ m) sieve, nearest 0.01 g.

13. Report: Test Data Sheet(s)/Form(s)

13.1 The methodology used to specify how data are recorded on the test data sheet(s)/form(s), as given below, is covered in 1.13 and in Practice D6026.

13.2 Record as a minimum the following general information (data):

13.2.1 Identification of the material being tested, such as the project identification, boring number, sample number, and depth.

13.2.2 Test number, if any, testing dates and the initials of the person(s) who performed the test.

13.2.3 The sample preparation method used: moist or air-dried

13.2.4 The specific gravity of the sedimentation specimen and indicate if the value is assumed or measured.

13.2.5 The following apparatus identification used during the test:

13.2.5.1 Hydrometer type (151H or 152H) and identification number.

13.2.5.2 Sedimentation cylinder identification number.

13.2.5.3 Thermometric device identification number.

13.2.5.4 Balance identification number.

13.2.5.5 Oven identification number.

13.2.5.6 Wet washing sieve identification number.

13.2.6 Description and classification of the soil in accordance with Practice D2488 or when Atterberg limit data are available, Practice D2487.

13.2.7 Describe any material that was excluded from the specimen.

13.2.8 Describe any problems that were encountered.

13.2.9 Indicate any prior testing performed on the specimen.

13.3 Record as a minimum the following test specimen data:

13.3.1 The size of the separation sieve used.

13.3.2 The estimated percentage passing the No. 200 (75- μ m) sieve, moist mass, and water content calculated or used in 9.5.

13.3.3 The water content of the material passing the No. 10 (2.0 mm) or finer sieve, if determined.

13.3.4 Moist mass of the sedimentation specimen.

13.3.5 Dry mass of the sedimentation specimen and indicate how obtained: using companion water content or direct measurement after testing.

13.3.6 Amount of dispersant used in the test.

13.3.7 The dry mass of the specimen plus dispersant, if applicable.

13.3.8 The percent passing the No. 200 (75- μ m) sieve.

- 13.3.9 The start time and date of the test.
- 13.3.10 Indicate if a foam inhibitor was used.
- 13.3.11 The maximum particle diameter of the material for each hydrometer reading.
- 13.3.12 The mass percent finer for each hydrometer reading.
- 13.3.13 The hydrometer, temperature, elapsed time, offset, and effective depth readings from the sedimentation test.
- 13.3.14 Tabulation of the mass percent finer including the particle diameter in mm.
- 13.3.15 A graph of the percent passing versus the log of particle size in mm.

NOTE 25—Appendix X1 shows an example data sheet and an example of the graphical display of the results of the test.

14. Precision and Bias

14.1 *Precision*—Test data on precision is not presented due to the nature of the soil materials tested by this test method. An ISR round-robin testing program was conducted; however, the data has not yet been compiled. Subcommittee D18.03 is in the process of determining how to report the data from the ISR round-robin testing.

14.2 *Bias*—There is no accepted reference value for this test method, therefore bias cannot be determined.

15. Keywords

15.1 clay; grain-size; hydrometer analysis; particle-size distribution (gradation); sedimentation; sieve analysis; silt

ANNEX

A1. CHECK OF HYDROMETER AND SEDIMENTATION CYLINDER

(Mandatory Information)

A1.1 *General*—There are many factors controlling the overall accuracy of sedimentation (hydrometer) test results. This section covers how the equipment constants used in calculating the sedimentation (hydrometer) test results are determined or checked. The equipment tolerances for the hydrometer and sedimentation cylinder are presented below.

A1.2 *Hydrometer Standard Dimensions* —The 152H and 151H hydrometers have specified dimensions in accordance with Specification E100, as shown in Fig. A1.1, and the hydrometer constants or equipment accuracy checks are listed with the accepted tolerances and summarized below.

A1.2.1 The distance from the key reference point on the nominal scale to the top or bottom of the hydrometer bulb H_t and H_b in mm. The key reference point on the nominal scale for 152H hydrometers is 0.0 g/L and 1.000 specific gravity for a 151H hydrometer.

A1.2.1.1 $H_t = 103 - 130$ mm, with an average of 116.5 mm.

A1.2.1.2 $H_b = 244 - 246$ mm.

A1.2.2 The overall length of the hydrometer bulb, H_{Lb} in mm.

A1.2.2.1 $H_{Lb} = 115 - 142$ mm, with an average of 128.5 mm.

A1.2.3 The distance from the top or bottom of the hydrometer’s bulb to the maximum diameter of the bulb, H_{ct} or H_{cb} in mm (Note A1.1).

NOTE A1.1—It is possible for the maximum diameter and the center of (volume) buoyancy to have different locations on the bulb. When calculating effective depth, the location of the center of (volume) buoyancy should be used to calculate H_{t1} and H_{t2} , not the location of the maximum diameter.

A1.2.3.1 H_{ct} or $H_{cb} = 58 - 71$ mm, with an average of 64.5 mm assuming the volume of the bulb is symmetrical.

A1.2.4 The distance from the key reference point on the nominal scale to the center of the bulb’s volume, H_{Lc} in mm.

A1.2.4.1 $H_{Lc} = 174 - 188$ mm, with an average of 181 mm.

A1.2.5 The length of the quoted nominal scale as stated in Specification E100, H_s in mm.

A1.2.5.1 $H_s = 82 - 84$ mm, with an average of 83 mm.

A1.2.6 The distance between scale divisions, ΔH_s in mm/division (Note A1.2).

A1.2.6.1 ΔH_s for 152H: Quoted scale of 0 – 50 g/L or 50 divisions, $\Delta H_s = 1.66 \pm 0.02$ mm. Full (actual) scale is -5 – 60 g/L.

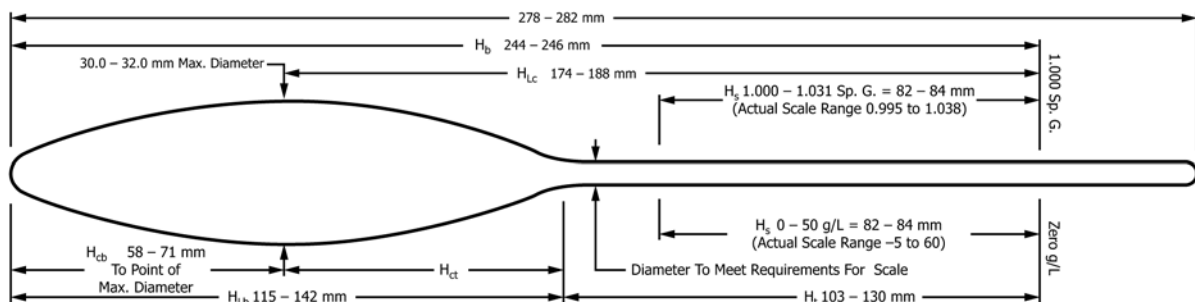

FIG. A1.1 Soil Hydrometer (151H or 152H)

A1.2.6.2 151H: Quoted scale of 1.000 – 1.031 specific gravity or 31 divisions, $\Delta H_s = 2.68 \pm 0.03$ mm. Full (actual) scale is 0.995 – 1.038 specific gravity.

A1.2.7 The submerged volume of the hydrometer bulb, V_{hb} in mL or cm^3 .

A1.2.7.1 V_{hb} is not a constant and shall be measured for each hydrometer.

A1.2.8 The accuracy of the scale key reference point(s) on the hydrometer scale.

A1.2.8.1 The scale key reference point for the 152H hydrometer is 0.0 ± 1 g/L and 1.000 ± 0.001 specific gravity for the 151H hydrometer read at the bottom of the meniscus.

A1.2.9 The length of the stem above and below the scale in mm.

A1.2.9.1 Stem shall be uniform and extend at least 15 mm above the top of the graduation and remain cylindrical for at least 3 mm below the lowest graduation.

NOTE A1.2—It is assumed that ΔH_s is uniform over the length of the scale; however, this assumption is not true in accordance with Test Method E126. The equation in Test Method E126 works fine for the 151H hydrometers, but not for the 152H hydrometers since they start at zero. Based on the Test Method E126 equation, the difference in ΔH_s at the top and bottom of the 151H scale is about 6 %.

A1.3 *Checking the Dimensions*—The dimensions provided in A1.2.1 through A1.2.8 shall be checked and documented prior to use. The dimensions provided in A1.2.9 shall be checked and documented once every 12 months. If any of the standard dimensions do not fall within the allowable ranges, the hydrometer shall not be used.

A1.3.1 *Distance/Length*—The length dimensions shall be made and recorded to the nearest 0.5 mm. They can be made using either, and given in order of preference: a height gauge (digimatic, dial, or vernier), calipers (digimatic, dial, or vernier), or a ruler and square (the square is used to transcribe the measurement from the hydrometer to the ruler). The line of contact between the hydrometer stem and bulb can be established and marked using one of two methods. The first choice is to measure the diameter of the stem with calipers, increasing this measurement by about 1 mm and marking the spot where the calipers encounter the bulb. The other method is to visually determine this line of contact and mark it. The visual determination may be assisted by feeling the contact point with fingers. Marking can be accomplished by placing lengthwise a thin strip of label paper/markings tape across the line of contact and then marking it with a pencil.

A1.3.2 *Scale Length*—The quoted scale length shall be measured and recorded to the nearest 0.5 mm using either calipers or a machinist ruler. The distance between scale divisions is simply that length divided by the number of divisions and recorded to the nearest 0.01 mm/div. The error stated in Note A1.1 is ignored.

A1.3.3 *Scale Key Reference Points*—The 152H hydrometer should read 0.0 ± 1 g/L and 1.000 ± 0.001 specific gravity for the 151H hydrometer at the bottom of the meniscus when placed in distilled water that is free of gas bubbles at the calibration temperature of the hydrometers. At temperatures

other than the calibration temperature of the hydrometer, the required reading shall be adjusted by the ratio of the density of water at the calibration temperature to the density of water at the check temperature. The check temperature shall be measured to the nearest 0.5°C and the density value associated with that temperature obtained from Table A1.1. If the hydrometer does not read within the allowable range, it shall not be used.

A1.3.4 *Volume*—The volume dimension, V_{hb} , shall be made and recorded to the nearest 1 cm^3 using either the direct or indirect method. The direct method is done by inserting the hydrometer into a graduated cylinder filled with test water having a minimum scale sensitivity of 5 mL per division. Read and record the volume in the cylinder prior to inserting the hydrometer to the nearest 2 mL. Insert the hydrometer into the test water just to the base of the stem then read and record the volume to the nearest 2 mL. The volume of the hydrometer is the difference in the volume readings before and after insertion into the test water. The volume is the average of three determinations that are within 2 mL of each other. The indirect method is done by determining the mass of the hydrometer. The volume can be measured by placing a partially filled beaker of room temperature test water on a balance, zero or tare the balance, and then lowering the hydrometer into the water just to the base of the stem. While holding the hydrometer in place, read and record the mass of displaced water to the nearest 0.1 g. Using an approximate mass density of water equal to unity (1), the volume of the hydrometer bulb in cm^3 will be equal to the mass reading.

A1.3.5 *Center of (Volume) Buoyancy*—Determine the center of (volume) buoyancy using the direct or indirect method described in A1.3.4, except the bulb is inserted until the mass or water level change is half of the volume of the bulb as determined in A1.3.4.

A1.4 *Sedimentation Cylinder Dimensions*—The sedimentation cylinder constants or equipment accuracy checks are listed with the accepted tolerances and summarized below. The cylinder shall be checked and documented prior to use.

A1.4.1 The accuracy of key volume mark is $1,000 \pm 5$ mL in mL or cm^3 .

A1.4.1.1 *Volume*—Verify the 1,000 mL mark is correct by performing the following steps. Place the cylinder on a balance and zero it. Add distilled water free of air bubbles, having a known temperature, T , nearest 1°C , to the cylinder until the balance reads the required mass, M_w . The mass, M_w , in g, equals 1,000 times the density of water, ρ_w , at T taken from Table A1.1. Read the water level at the bottom of the meniscus. The level should be within about 5 mL or ~ 2 mm of the 1,000 mL mark on the cylinder. If the mark is not correct, remark the cylinder with the correct 1,000 mL line or do not use the cylinder. If the cylinder is remarked, the correct or incorrect line shall be clearly marked as such to prevent misuse of the incorrect line marking. Record the volume to the nearest 0.1 cm^3 .

A1.4.2 The inside area, A_c , in cm^2 .

A1.4.2.1 *Area*—Determine the inside area of the cylinder, A_c , by using a commercial-grade meter stick or tape measure

TABLE A1.1 Density of Water (ρ_w) Versus Temperature (T)^A

T (°C)	ρ_w (g/ML)	T (°C)	ρ_w (g/ML)	T (°C)	ρ_w (g/ML)	T (°C)	ρ_w (g/ML)
15.0	0.99910	16.0	0.99895	17.0	0.99878	18.0	0.99860
.1	0.99909	.1	0.99893	.1	0.99876	.1	0.99858
.2	0.99907	.2	0.99891	.2	0.99874	.2	0.99856
.3	0.99906	.3	0.99890	.3	0.99872	.3	0.99854
.4	0.99904	.4	0.99888	.4	0.99871	.4	0.99852
.5	0.99902	.5	0.99886	.5	0.99869	.5	0.99850
.6	0.99901	.6	0.99885	.6	0.99867	.6	0.99848
.7	0.99899	.7	0.99883	.7	0.99865	.7	0.99847
.8	0.99898	.8	0.99881	.8	0.99863	.8	0.99845
.9	0.99896	.9	0.99879	.9	0.99862	.9	0.99843
19.0	0.99841	20.0	0.99821	21.0	0.99799	22.0	0.99777
.1	0.99839	.1	0.99819	.1	0.99797	.1	0.99775
.2	0.99837	.2	0.99816	.2	0.99795	.2	0.99773
.3	0.99835	.3	0.99814	.3	0.99793	.3	0.99770
.4	0.99833	.4	0.99812	.4	0.99791	.4	0.99768
.5	0.99831	.5	0.99810	.5	0.99789	.5	0.99766
.6	0.99829	.6	0.99808	.6	0.99786	.6	0.99764
.7	0.99827	.7	0.99806	.7	0.99784	.7	0.99761
.8	0.99825	.8	0.99804	.8	0.99782	.8	0.99759
.9	0.99823	.9	0.99802	.9	0.99780	.9	0.99756
23.0	0.99754	24.0	0.99730	25.0	0.99705	26.0	0.99679
.1	0.99752	.1	0.99727	.1	0.99702	.1	0.99676
.2	0.99749	.2	0.99725	.2	0.99700	.2	0.99673
.3	0.99747	.3	0.99723	.3	0.99697	.3	0.99671
.4	0.99745	.4	0.99720	.4	0.99694	.4	0.99668
.5	0.99742	.5	0.99717	.5	0.99692	.5	0.99665
.6	0.99740	.6	0.99715	.6	0.99689	.6	0.99663
.7	0.99737	.7	0.99712	.7	0.99687	.7	0.99660
.8	0.99735	.8	0.99710	.8	0.99684	.8	0.99657
.9	0.99732	.9	0.99707	.9	0.99681	.9	0.99654
27.0	0.99652	28.0	0.99624	29.0	0.99595	30.0	0.99565
.1	0.99649	.1	0.99621	.1	0.99592	.1	0.99562
.2	0.99646	.2	0.99618	.2	0.99589	.2	0.99559
.3	0.99643	.3	0.99615	.3	0.99586	.3	0.99556
.4	0.99641	.4	0.99612	.4	0.99583	.4	0.99553
.5	0.99638	.5	0.99609	.5	0.99580	.5	0.99550
.6	0.99635	.6	0.99607	.6	0.99577	.6	0.99547
.7	0.99632	.7	0.99604	.7	0.99574	.7	0.99544
.8	0.99629	.8	0.99601	.8	0.99571	.8	0.99541
.9	0.99627	.9	0.99598	.9	0.99568	.9	0.99538

^AReference: CRC Handbook of Chemistry and Physics, David R. Lide, Editor-In-Chief, 74th Edition, 1993 – 1994.

reading in cm or mm. Insert the meter stick or tape measure into the cylinder until it touches the inside bottom of the cylinder. Read and record the distance from the inside bottom of the cylinder to the 1,000 mL mark to the nearest 1 mm. Repeat this procedure at two more locations on the inside bottom of the cylinder for a total of three readings. Determine and record the average distance, D_{1000} , to the nearest 1 mm. Calculate and record the area of the cylinder, A_c , ($A_c = 1,000 \times (10/D_{1000})$) to the nearest 0.1 cm².

NOTE A1.3—For example, if the 1,000 mL mark is determined to be 360 mm from the inside bottom of the cylinder, the inside area is 27.8 cm² and

the diameter is then 59.5 mm. For a 63.5 mm inside diameter cylinder, the 1,000 mL mark should be approximately 316 mm from the inside bottom.

A1.4.3 The inside area's uniformity above the key volume mark.

A1.4.3.1 *Area Uniformity*—Determine and record the uniformity of the area above the 1,000 mL. Add 150 ± 1 mL or $150 \pm 1g \times \rho_w$ at T of bubble free, distilled water to the cylinder filled with 1,000 mL of distilled water. If the water surface raises $150 \times (10/A_c) \pm 0.25$ mm, then the area is considered uniform. If this tolerance isn't met, the cylinder shall not be used.

APPENDIX

X1. EXAMPLE DATA SHEETS, GRAPH, AND EQUIPMENT CHECKS

(Nonmandatory Information)

X1.1 *General*—The data sheets in Fig. X1.1 and Fig. X1.2 are provided as examples to assist the user by showing results of the calculations performed. Fig. X1.3 is provided as an example of how the results of Fig. X1.1 can be displayed graphically. Fig. X1.1 data is calculated using the calibration

relationship and Fig. X1.2 data is calculated using the companion cylinder. Figs. X1.4-X1.6 are examples of typical checks of the hydrometer and sedimentation cylinder. Fig. X1.7 is an example of the meniscus correction and determination of the A constant for a 151H hydrometer.

HYDROMETER ANALYSIS (ASTM D7928)																																															
DATE 08/15/15		PROJECT NAME: Example			PROJECT NO.: 081515																																										
Boring: 1		Visual Identification: _____																																													
Sample: 27		Test No.: NA																																													
Depth (ft): 5.0		Prior Testing: <input checked="" type="checkbox"/> No		Yes: Type: _____																																											
Balance ID: BA-001		Thermometer ID: TD-001		Separation Sieve: <input checked="" type="checkbox"/> No. 10		or: _____																																									
Oven ID: OV-001		Wet Wash Sieve ID: WWSV-200-1		Specimen Prep Method: <input checked="" type="checkbox"/> Moist		<input type="checkbox"/> Air Dried																																									
<table border="1" style="width: 100%; border-collapse: collapse;"> <tr><td colspan="2">Estimated Moist Mass</td></tr> <tr><td>W_{cest} (%):</td><td>12</td></tr> <tr><td>%_{est}:</td><td>90</td></tr> <tr><td>M_{mest} (g):</td><td>56</td></tr> </table>		Estimated Moist Mass		W _{cest} (%):	12	% _{est} :	90	M _{mest} (g):	56	<table border="1" style="width: 100%; border-collapse: collapse;"> <tr><td colspan="2">Mass of Moist Soil, M_m (g)</td></tr> <tr><td colspan="2" style="text-align: center;">59.19</td></tr> <tr><td colspan="2">Specimen-mixing Container ID: KS-1</td></tr> </table>		Mass of Moist Soil, M _m (g)		59.19		Specimen-mixing Container ID: KS-1		<table border="1" style="width: 100%; border-collapse: collapse;"> <tr><td colspan="2">Dry Mass of Soil from Water Content</td></tr> <tr><td>Tare No.:</td><td>K33</td></tr> <tr><td>Wet Soil + tare (g):</td><td>33.27</td></tr> <tr><td>Dry Soil + tare (g):</td><td>31.44</td></tr> <tr><td>Tare Mass (g):</td><td>14.21</td></tr> <tr><td>Water Content (%):</td><td>10.6</td></tr> <tr><td>Dry Mass, M_d (g):</td><td>53.51</td></tr> </table>		Dry Mass of Soil from Water Content		Tare No.:	K33	Wet Soil + tare (g):	33.27	Dry Soil + tare (g):	31.44	Tare Mass (g):	14.21	Water Content (%):	10.6	Dry Mass, M _d (g):	53.51	<table border="1" style="width: 100%; border-collapse: collapse;"> <tr><td colspan="2">Dry Mass of Soil Direct Meas.</td></tr> <tr><td>Tare No.:</td><td>_____</td></tr> <tr><td>M_{dd} + tare (g):</td><td>_____</td></tr> <tr><td>Tare Mass (g):</td><td>_____</td></tr> <tr><td>M_{dd} (g):</td><td>_____</td></tr> <tr><td>Dry Mass, M_d (g):</td><td>_____</td></tr> </table>		Dry Mass of Soil Direct Meas.		Tare No.:	_____	M _{dd} + tare (g):	_____	Tare Mass (g):	_____	M _{dd} (g):	_____	Dry Mass, M _d (g):	_____
Estimated Moist Mass																																															
W _{cest} (%):	12																																														
% _{est} :	90																																														
M _{mest} (g):	56																																														
Mass of Moist Soil, M _m (g)																																															
59.19																																															
Specimen-mixing Container ID: KS-1																																															
Dry Mass of Soil from Water Content																																															
Tare No.:	K33																																														
Wet Soil + tare (g):	33.27																																														
Dry Soil + tare (g):	31.44																																														
Tare Mass (g):	14.21																																														
Water Content (%):	10.6																																														
Dry Mass, M _d (g):	53.51																																														
Dry Mass of Soil Direct Meas.																																															
Tare No.:	_____																																														
M _{dd} + tare (g):	_____																																														
Tare Mass (g):	_____																																														
M _{dd} (g):	_____																																														
Dry Mass, M _d (g):	_____																																														
Dispersion/Mixing																																															
Date Dispersed/Mixed: 08/17/15		Dispersion Device: <input checked="" type="checkbox"/> cup & mixer		air jet: <input type="checkbox"/>		69 kPa 172 kPa																																									
Mixing Method: <input checked="" type="checkbox"/> agitator		Tipping: Time: _____		Amount of Dispersant, M _{disp} (g)		5.03																																									
				Direct Add. <input checked="" type="checkbox"/> Dissolved in 100 mL water <input type="checkbox"/>																																											
		Contents mixed using: _____																																													
Temperature-Density Correction: <input type="checkbox"/> Control Cyl.		<input checked="" type="checkbox"/> Calib. Relationship		Foam Inhibitor Used: <input type="checkbox"/> Yes <input checked="" type="checkbox"/> No																																											
Temperature Control: <input checked="" type="checkbox"/> Room control		<input type="checkbox"/> Chamber/Water bath		Flocculation?: <input type="checkbox"/> Yes <input checked="" type="checkbox"/> No																																											
Hydrometer ID.		HY-002		No. 200 Wash Information																																											
Type: <input checked="" type="checkbox"/> 151H <input type="checkbox"/> 152H				Oven Drying Container ID:		JG-33																																									
				Container Mass, (g)		0.00																																									
Sedimentation Cylinder No.		1		Dry Mass Retained after Washing + tare, (g):		6.24																																									
				Dry Mass Retained after Washing over No. 200 Sieve, M _{dr} (g)		6.24																																									
Starting Date (mm/dd/yr)		8/18/2015		% Passing the No. 200 Sieve		88.3																																									
Starting Time (hr:min:sec)		10:18:00		Specific Gravity of Soil		2.67																																									
				<input type="checkbox"/> Assumed <input checked="" type="checkbox"/> Measured																																											
Elapsed Time, T (min)	Hydrometer Reading r _m		Temp (°C)	Offset r _{d,m}	Effective Depth, H _m (cm)	D (mm)	Mass Percent (%) Finer, N _m																																								
0	NA		NA	NA	NA	NA	NA																																								
1	15.75	1.01575	22.5	1.0048	12	0.047	33																																								
2	13.75	1.01375	22.5	1.0048	13	0.034	27																																								
5	11.00	1.011	22.5	1.0048	13	0.022	18																																								
8	10.00	1.010	22.5	1.0048	14	0.018	15																																								
15	9.00	1.009	22.0	1.0049	14	0.013	12																																								
30	7.50	1.0075	22.0	1.0049	14	0.0094	8																																								
60	7.00	1.007	22.0	1.0049	15	0.0067	6																																								
240	6.50	1.0065	22.0	1.0049	15	0.0033	5																																								
1440	6.25	1.00625	20.0	1.0054	15	0.0014	3																																								
						Meniscus Correction, C _m : 0.0005																																									
						A constant: 1.0075																																									
*Describe if any material was excluded and if any problems were encountered.																																															
*REMARKS: _____																																															

Tested By: KA Calculated By: KA Checked By: GA
 Date: 08/18/15 Date: 08/20/15 Date: 08/20/15

FIG. X1.1 Example Data Sheet Using Calibration Relationship

HYDROMETER ANALYSIS (ASTM D7928)																																	
DATE 08/15/15		PROJECT NAME: Example			PROJECT NO.: 081515																												
Boring: 1		Visual Identification:																															
Sample: 27		Test No.: NA																															
Depth (ft): 5.0		Prior Testing: <input checked="" type="checkbox"/> No		Yes: Type:																													
Balance ID: BA- 001		Thermometer ID: TD- 001		Separation Sieve: <input checked="" type="checkbox"/> No. 10 or:																													
Oven ID: OV- 001		Wet Wash Sieve ID: WWSV- 200-1		Specimen Prep Method: <input checked="" type="checkbox"/> Moist <input type="checkbox"/> Air Dried																													
<table border="1" style="width:100%; border-collapse: collapse;"> <tr><td colspan="2">Estimated Moist Mass</td></tr> <tr><td>W_{cest} (%): 12</td></tr> <tr><td>%best: 90</td></tr> <tr><td>M_{mest} (g): 56</td></tr> </table>		Estimated Moist Mass		W _{cest} (%): 12	%best: 90	M _{mest} (g): 56	<table border="1" style="width:100%; border-collapse: collapse;"> <tr><td colspan="2">Mass of Moist Soil, M_m (g)</td></tr> <tr><td colspan="2" style="text-align: center;">59.19</td></tr> <tr><td colspan="2">Specimen-mixing Container ID: KS-1</td></tr> </table>		Mass of Moist Soil, M _m (g)		59.19		Specimen-mixing Container ID: KS-1		<table border="1" style="width:100%; border-collapse: collapse;"> <tr><td colspan="2">Dry Mass of Soil from Water Content</td></tr> <tr><td>Tare No.: K33</td></tr> <tr><td>Wet Soil + tare (g): 33.27</td></tr> <tr><td>Dry Soil + tare (g): 31.44</td></tr> <tr><td>Tare Mass (g): 14.21</td></tr> <tr><td>Water Content (%): 10.6</td></tr> <tr><td>Dry Mass, M_d (g): 53.51</td></tr> </table>		Dry Mass of Soil from Water Content		Tare No.: K33	Wet Soil + tare (g): 33.27	Dry Soil + tare (g): 31.44	Tare Mass (g): 14.21	Water Content (%): 10.6	Dry Mass, M _d (g): 53.51	<table border="1" style="width:100%; border-collapse: collapse;"> <tr><td colspan="2">Dry Mass of Soil Direct Meas.</td></tr> <tr><td>Tare No.:</td></tr> <tr><td>M_{dd} + tare (g):</td></tr> <tr><td>Tare Mass (g):</td></tr> <tr><td>M_{dd} (g):</td></tr> <tr><td>Dry Mass, M_{dr} (g):</td></tr> </table>		Dry Mass of Soil Direct Meas.		Tare No.:	M _{dd} + tare (g):	Tare Mass (g):	M _{dd} (g):	Dry Mass, M _{dr} (g):
Estimated Moist Mass																																	
W _{cest} (%): 12																																	
%best: 90																																	
M _{mest} (g): 56																																	
Mass of Moist Soil, M _m (g)																																	
59.19																																	
Specimen-mixing Container ID: KS-1																																	
Dry Mass of Soil from Water Content																																	
Tare No.: K33																																	
Wet Soil + tare (g): 33.27																																	
Dry Soil + tare (g): 31.44																																	
Tare Mass (g): 14.21																																	
Water Content (%): 10.6																																	
Dry Mass, M _d (g): 53.51																																	
Dry Mass of Soil Direct Meas.																																	
Tare No.:																																	
M _{dd} + tare (g):																																	
Tare Mass (g):																																	
M _{dd} (g):																																	
Dry Mass, M _{dr} (g):																																	
Dispersion/Mixing																																	
Date Dispersed/Mixed: 08/17/15		Dispersion Device: <input checked="" type="checkbox"/> cup & mixer <input type="checkbox"/> air jet: 69 kPa <input type="checkbox"/> 172 kPa																															
Mixing Method: <input checked="" type="checkbox"/> agitator <input type="checkbox"/> Tipping: Time: _____		Amount of Dispersant, M _{disp} (g) Direct Add. <input checked="" type="checkbox"/> Dissolved in 100mL water <input type="checkbox"/> 5.03 Contents mixed using:																															
Temperature-Density Correction: <input checked="" type="checkbox"/> Control Cyl. <input type="checkbox"/> Calib. Relationship		Temperature Control: <input checked="" type="checkbox"/> Room control <input type="checkbox"/> Chamber/Water bath			Foam Inhibitor Used: <input type="checkbox"/> Yes <input checked="" type="checkbox"/> No Flocculation?: <input type="checkbox"/> Yes <input checked="" type="checkbox"/> No																												
Hydrometer ID. Type: <input checked="" type="checkbox"/> 151H <input type="checkbox"/> 152H		HY-002		No. 200 Wash Information																													
Sedimentation Cylinder No. 1		Oven Drying Container ID: JG-33		Container Mass, (g): 0.00																													
Starting Date (mm/dd/yr) 8/18/15		Dry Mass Retained after Washing + tare, (g): 6.24		Dry Mass Retained after Washing over No. 200 Sieve, M _d (g): 6.24																													
Starting Time (hr:min:sec) 10:18:00		% Passing the No. 200 Sieve: 88		Specific Gravity of Soil <input type="checkbox"/> Assumed <input checked="" type="checkbox"/> Measured: 2.67																													
Elapsed Time, T (min)	Hydrometer Reading r _m		Temp (°C)	Offset r _{d,m}	Effective Depth, H _m (cm)	D (mm)																											
0	NA		NA	NA	NA	NA																											
1	15.75	1.01575	22.5	1.00475	12	0.047																											
2	13.75	1.01375			13	0.034																											
5	11.00	1.011			13	0.022																											
8	10.00	1.010			14	0.018																											
15	9.00	1.009	22.0	1.0050	14	0.013																											
30	7.50	1.0075	22.0	1.0050	14	0.0094																											
60	7.00	1.007	22.0	1.0050	15	0.0067																											
240	6.50	1.0065	22.0	1.0050	15	0.0033																											
1440	6.25	1.00625	20.0	1.00525	15	0.0014																											
Meniscus Correction, C _m : 0.0005					A constant: 1.0075																												
*Describe if any material was excluded and if any problems were encountered.																																	
*REMARKS:																																	

Tested By: KA
Date: 08/18/15

Calculated By: KA
Date: 08/20/15

Checked By: GA
Date: 08/20/15

FIG. X1.2 Example Data Sheet Using Companion Measurement

**PARTICLE SIZE DISTRIBUTION
ASTM D7928**

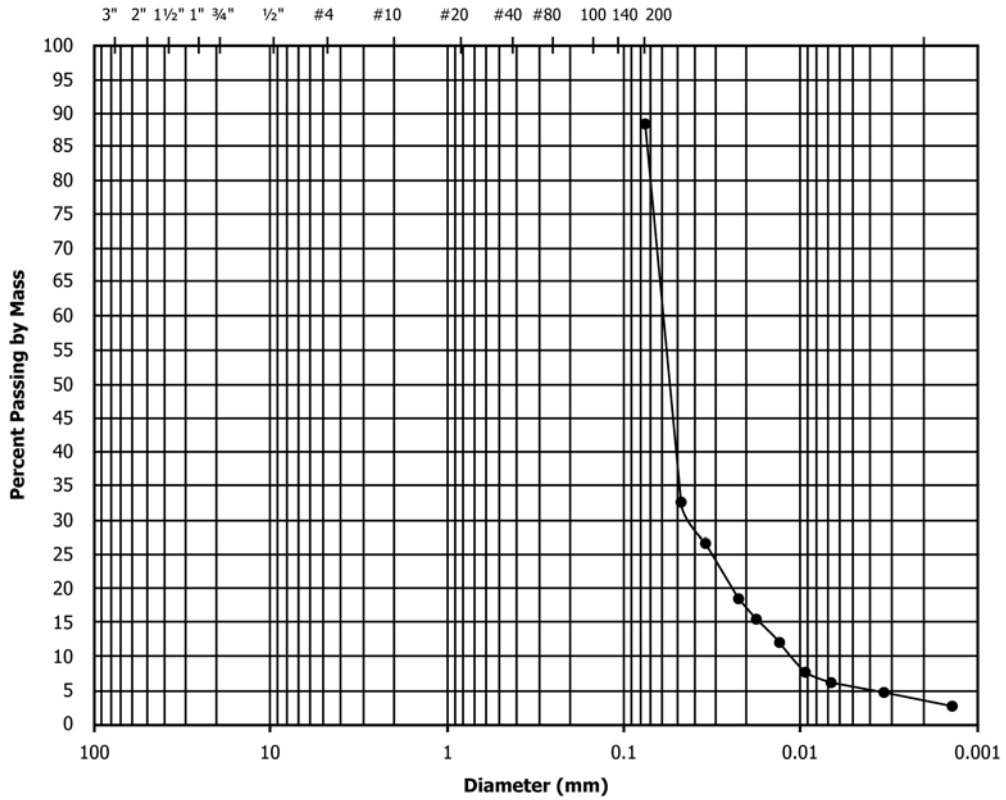

Sand (%)	Fines (%)	
11.7	88.3	
	Silt	Clay
	85.0	3.3

Project No.: 081515 -- Project Name: Example

Boring: 1

Sample: 27 - Depth: 5 ft.

FIG. X1.3 Typical Graph of Data

Check of Hydrometers

Procedure: **D7928**

Date: 08/01/15

Location: Soils Lab

Date Due*: Before use/After Repair

Temperature 22 °C = 72 °F

*1 yr due date for items marked with *.

Check/Standard Equipment

Type:	Caliper
Manufacturer:	Pittsburgh
Model Number:	68304
Serial Number:	NA
Instrument Number:	XCD-001
Date Due:	20/03/16

Type:	Thermometer
Manufacturer:	Hanna
Model Number:	HI935007N
Serial Number:	08617836
Instrument Number:	TD-001
Date Due:	4/2/16

Type:	Balance
Manufacturer:	Sartorius
Model Number:	3102-1S
Serial Number:	0032950176
Instrument Number:	BA-003
Date Due:	6/8/16

Instrument Identification/Data

Type	Hydrometer
Manufacturer	Chase
Model Number	NA
Serial Number	305055
Instrument Number	HY-002 <input checked="" type="checkbox"/> 151H <input type="checkbox"/> 152H
Previous Verification Date:	New

Check Data

Instrument	PASS/FAIL	Tolerance (mm)	
Top of Scale to Top of Hydrometer Bulb, H _t (mm):	112.0	PASS	103-130
Top of Scale to Bottom of Hydrometer Bulb, H _b (mm):	246.0	PASS	244-246
Overall Length of Hydrometer Bulb, H _{lb} (mm):	134.0	PASS	115-142
Top of Hydrometer Bulb to Maximum Diameter, H _{ct} (mm):	63.0	PASS	58-71
Bottom of Hydrometer Bulb to Maximum Diameter, H _{cb} (mm):	71.0	PASS	58-71
Top of Scale (1.000) to Maximum Diameter, H _{lc} (mm):	174.0	PASS	174-188
Nominal Scale Length (1.000-1.031 or 0-50 g/L), (mm):	82.0	PASS	82-84
Distance Between Scale Divisions, Δ H _s , (mm/div):	2.65	PASS	1.64-1.68 2.65-2.71
Submerged Volume of Hydrometer Bulb, V _{lb} , (cm ³):	54	PASS	NA
Scale Reference Point (Sp.Gr or g/L):	1.001	PASS	1.001-0.999 1.0-1.0
*Stem extends 15 mm above the top graduation?:	Yes	PASS	Yes
*Stem cylindrical for at least 3 mm below lowest graduation?:	Yes	PASS	Yes
Stem Diameter (mm):	5.2	PASS	NA
Center of (Volume) Buoyancy, C _b , (cm ³):	27.0	PASS	NA
Top of Scale (0.995) to Center of Buoyancy, H _{t1} , (mm):	186.0	PASS	NA
Bottom of Scale (1.038) to Center of Buoyancy, H _{t2} , (mm):	70.0	PASS	NA

² Mass of Displaced Water

1 53.9 g

2 53.9 g

3 53.9 g

Avg. 53.9 g

³ Temperature (°C): 22.0

Scale Rdg: 1.0001

Adj. Rdg: 1.0005

Equip. Status (Conforms/Nonconforms*): _____

*Who was notified? _____

Action Taken: _____

Checked By: KA

Input By: KA

Sticker Applied By: Not Applicable

Checked By: GA

Date: 08/01/15

Date: 08/01/15

Date: -

Date: 08/01/15

FIG. X1.4 Example Hydrometer Check

Check of Sedimentation Cylinders

Procedure: ASTM D7928
 Location: Soils Lab

Date: 08/01/15
 Date Due: Before Use/After Repair
 Temperature 27 °C = 80 °F

Check/Standard Equipment

Type: Caliper	Type: Thermometer	Type: Balance	Type: Tape Measure
Manufacturer: Pittsburgh	Manufacturer: Hanna	Manufacturer: Sartorius	Instr. No.: 1
Model Number: 68304	Model Number: HI935007N	Model Number: 3102-1S	Date Due: NA
Serial Number: NA	Serial Number: 08617836	Serial Number: 0032950176	
Instrument Number: XCD-001	Instrument Number: TD-001	Instrument Number: BA-003	
Date Due: 3/20/2016	Date Due: 4/2/2016	Date Due: 6/8/2016	

Instrument Identification/Data

Type	Sedimentation Cylinder
Manufacturer	Kimax/Durham Geo
Model Number	NA
Serial Number	NA
Instrument Number	2
Previous Verification Date:	New

Check Data

	Instrument	PASS/FAIL	Tolerance (mm)		Inside Ht. (mm) Orig.	Inside Ht. (mm) Adj.
Height of Cylinder (mm):	451	PASS	~457		1 356	1
Temperature, °C	27	PASS	NA		2 356	2
Mass of Cylinder with water (g):	1002.1	PASS	NA		3 356	3
Density of Water, g/mL	0.99652	PASS	NA		Avg: 356	Avg:
Inside Area before adjustment, cm ² :	28.1	PASS	22.9-32.2			
Calculated Inside Diameter (mm):	60	PASS	55-64			
Unadjusted Volume, mL	999	PASS	995-1005			
Adjusted Mass of Cylinder w/ water (g):			NA			
Adjusted Volume, mL			995-1005			
Inside Area after adjustment, cm ² :			22.9-32.2			
Area Uniformity (mm):	53.3	PASS	53.2-53.7			

Amt. added: 149 mL

Equip. Status (Conforms/Nonconforms*): Conforms *Who was notified? _____ Action Taken: _____
 Checked By: KA Input By: KA Sticker Applied By: Not applicable Checked By: GA
 Date: 08/01/15 Date: 08/01/15 Date: - Date: 08/01/15

FIG. X1.5 Example Sedimentation Cylinder Check—No Adjustment

Check of Sedimentation Cylinders

Procedure: ASTM D7928
 Location: Soils Lab

Date: 08/01/15
 Date Due: Before Use/After Repair
 Temperature 27 °C = 80 °F

Check/Standard Equipment

Type: Caliper	Type: Thermometer	Type: Balance	Type: Tape Measure
Manufacturer: Pittsburgh	Manufacturer: Hanna	Manufacturer: Sartorius	Instr. No.: 1
Model Number: 68304	Model Number: HI935007N	Model Number: 3102-1S	Date Due: NA
Serial Number: NA	Serial Number: 08617836	Serial Number: 0032950176	
Instrument Number: XCD-001	Instrument Number: TD-001	Instrument Number: BA-003	
Date Due: 3/20/2016	Date Due: 4/2/2016	Date Due: 6/8/2016	

Instrument Identification/Data

Type	Sedimentation Cylinder
Manufacturer	Kimax/Durham Geo
Model Number	NA
Serial Number	NA
Instrument Number	1
Previous Verification Date:	New

Check Data

	Instrument	PASS/FAIL	Tolerance (mm)	Inside Ht. (mm) Orig.	Inside Ht. (mm) Adj.
Height of Cylinder (mm):	451	PASS	~457	1 343	1 348
Temperature, °C	27	PASS	NA	2 343	2 347
Mass of Cylinder with water (g):	987.9	PASS	NA	3 343	3 347
Density of Water, g/mL	0.99652	PASS	NA	Avg: 343	Avg: 347
Inside Area before adjustment, cm ² :	29.2	PASS	22.9-32.2		
Calculated Inside Diameter (mm):	61	PASS	55-64		
Unadjusted Volume, mL	984	FAIL	995-1005		
Adjusted Mass of Cylinder w/ water (g):	998.5	PASS	NA		
Adjusted Volume, mL	995	PASS	995-1005		
Inside Area after adjustment, cm ² :	28.8	PASS	22.9-32.2		
Area Uniformity (mm):	52.2	PASS	51.9-52.4		

Amt. added: 150 mL

Equip. Status (Conforms/Nonconforms*): Initially: NC After Adj.: C

*Who was notified? Lab Manager

Action Taken: Line remarked.

Checked By: KA

Input By: KA

Sticker Applied By: Not applicable

Checked By: GA

Date: 08/01/15

Date: 08/01/15

Date: -

Date: 08/01/15

FIG. X1.6 Example Sedimentation Cylinder Check—Adjustment

Determination of the Constant A & C_m for Sedimentation Analysis

Procedure: **ASTM D7928**

Location: Soils Lab

Date: 08/01/15

Temperature 27 °C = 80 °F

Standard Equipment

Type:	Sed. Cylinder
Manufacturer:	Kimax/Durham Geo
Model Number:	NA
Serial Number:	NA
Instrument Number:	1
Date Due:	NA

Type:	Thermometer
Manufacturer:	Hanna
Model Number:	HI935007N
Serial Number:	08617836
Instrument Number:	TD-001
Date Due:	4/2/2016

Type:	Hydrometer
Manufacturer:	Chase
Model Number:	151H
Serial Number:	305055
Instrument Number:	HY-002
Date Due:	NA

Data

Amount of Dispersant: 5.0 g

Top of Meniscus Reading:	<u>0.9995</u>
Plane Intersection Reading:	<u>1.0000</u>
Meniscus Correction, C _m :	<u>0.0005</u>

Temperature °C	Hydrometer Reading, R _{151,t}	A
18.4	1.0055	1.0073
20.3	1.00525	1.0075
22.8	1.005	1.0078
23.7	1.00475	1.0077
27.3	1.00325	1.0072
Average:		1.0075
Std. Dev.:		0.0003
		PASS

Verified By: KA

Date: 08/01/15

Input By: KA

Date: 08/01/15

Checked By: GA

Date: 08/01/15

FIG. X1.7 Example of Constant A and Meniscus Correction Determination

ASTM International takes no position respecting the validity of any patent rights asserted in connection with any item mentioned in this standard. Users of this standard are expressly advised that determination of the validity of any such patent rights, and the risk of infringement of such rights, are entirely their own responsibility.

This standard is subject to revision at any time by the responsible technical committee and must be reviewed every five years and if not revised, either reapproved or withdrawn. Your comments are invited either for revision of this standard or for additional standards and should be addressed to ASTM International Headquarters. Your comments will receive careful consideration at a meeting of the responsible technical committee, which you may attend. If you feel that your comments have not received a fair hearing you should make your views known to the ASTM Committee on Standards, at the address shown below.

This standard is copyrighted by ASTM International, 100 Barr Harbor Drive, PO Box C700, West Conshohocken, PA 19428-2959, United States. Individual reprints (single or multiple copies) of this standard may be obtained by contacting ASTM at the above address or at 610-832-9585 (phone), 610-832-9555 (fax), or service@astm.org (e-mail); or through the ASTM website (www.astm.org). Permission rights to photocopy the standard may also be secured from the Copyright Clearance Center, 222 Rosewood Drive, Danvers, MA 01923, Tel: (978) 646-2600; http://www.copyright.com/