



Standard Test Method for Engine Coolant Corrosion Protection Under Accelerated Thermal and Oxidizing Conditions Using a Rotating Pressure Vessel¹

This standard is issued under the fixed designation D7820; the number immediately following the designation indicates the year of original adoption or, in the case of revision, the year of last revision. A number in parentheses indicates the year of last reapproval. A superscript epsilon (ϵ) indicates an editorial change since the last revision or reapproval.

1. Scope

1.1 This test method covers determination of engine coolant corrosion protection and stability under accelerated thermal and oxidizing conditions using a rotary pressure vessel.

1.2 The values stated in SI units are to be regarded as the standard. The values given in parentheses are for information only.

1.3 *This standard does not purport to address all of the safety concerns, if any, associated with its use. It is the responsibility of the user of this standard to establish appropriate safety and health practices and determine the applicability of regulatory limitations prior to use.* Specific hazard statements are given in [6.2](#), [6.3](#), [6.4](#), [6.5](#), [6.7](#), [6.8](#), [6.9](#), [6.10](#), [11.1](#), [12.8](#), [12.9](#), and [12.10](#).

2. Referenced Documents

2.1 *ASTM Standards:*²

[B32 Specification for Solder Metal](#)

[D1176 Practice for Sampling and Preparing Aqueous Solutions of Engine Coolants or Antirusts for Testing Purposes](#)

[D1193 Specification for Reagent Water](#)

[D1384 Test Method for Corrosion Test for Engine Coolants in Glassware](#)

[D2272 Test Method for Oxidation Stability of Steam Turbine Oils by Rotating Pressure Vessel](#)

[E1 Specification for ASTM Liquid-in-Glass Thermometers](#)

[E230 Specification and Temperature-Electromotive Force \(EMF\) Tables for Standardized Thermocouples](#)

3. Summary of Test Method

3.1 The engine coolant test fluid and a metal coupon bundle are placed in a covered glassware container in a pressure vessel

¹ This test method is under the jurisdiction of ASTM Committee D15 on Engine Coolants and Related Fluids and is the direct responsibility of Subcommittee D15.21 on Extended Life Coolants.

Current edition approved Nov. 1, 2012. Published December 2012. DOI: 10.1520/D7820-12.

² For referenced ASTM standards, visit the ASTM website, www.astm.org, or contact ASTM Customer Service at service@astm.org. For *Annual Book of ASTM Standards* volume information, refer to the standard's Document Summary page on the ASTM website.

equipped with a pressure gauge. The pressure vessel is charged with air or oxygen to a gage pressure of 620 kPa (90 psi, 6.2 bar) (see conversion factor 1), placed in a constant-temperature oil bath set at a controlled temperature (typically 115°C (239°F) or 150°C (302°F)) and rotated axially at 100 rpm at an angle of 30° from horizontal for 168 h. The use of air or oxygen and test temperature is left to the discretion of the user of the test. Engine coolant performance is assessed for corrosion protection based on changes in metal coupon weights and coolant stability is evaluated based on changes in coolant physical and compositional properties. The test method is based on a combination of ASTM [D1384](#) (modified metal coupon bundle) and ASTM [D2272](#) (glassware, pressure vessel, and bath apparatus) test procedures.

$$100 \text{ kPa} = 1.00 \text{ bar} = 14.5 \text{ psi} \quad (1)$$

4. Significance and Use

4.1 Engines operating under severe conditions involving high temperatures, hot spot areas, entrained air, and/or small cooling systems are placing greater emphasis on engine coolant oxidation stability and corrosion protection. This standard provides an accelerated test method to assess engine coolant performance under high temperature oxidizing test conditions of new, used, and/or recycled engine coolants. The test method may also serve as a screening tool to determine oxidation stability. The test results of this method cannot stand alone as evidence of satisfactory oxidation stability and corrosion protection. The actual service of an engine coolant formulation can be determined only by more comprehensive bench, dynamometer, and field tests.

5. Apparatus

5.1 *Oxidation Vessel, Glass Sample Container with Four-Hole Polytetrafluoroethylene (PTFE) Disk, Hold-Down Spring, Pressure Gage, and Test Bath*, as described in [Annex A1](#). The assembled apparatus is shown schematically in [Fig. 1](#) and [Fig. A1.5](#).

5.2 *Temperature-Measuring Instrument (Environmentally Safe Thermometer or Thermocouple)*—An ASTM partial immersion temperature-measuring instrument having a range from –20 to 150°C (0 to 302°F) and conforming to the

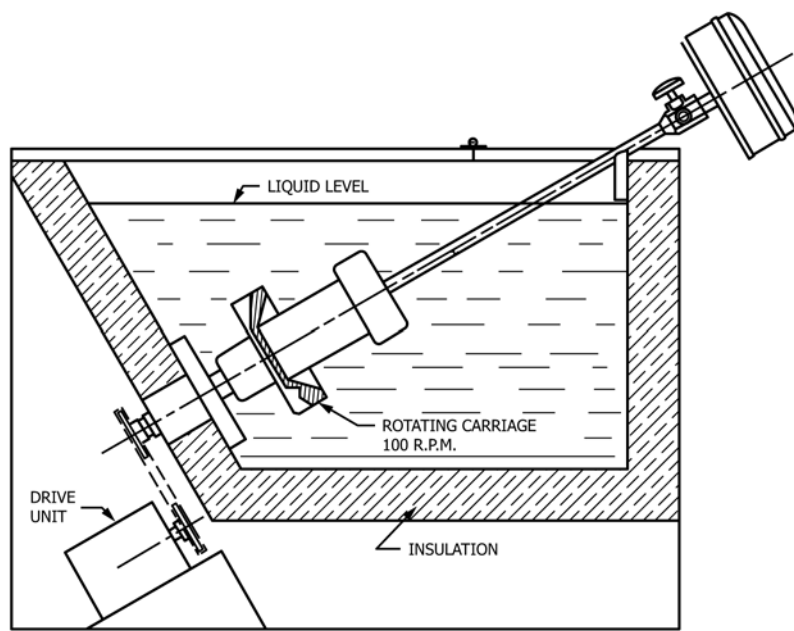

FIG. 1 Schematic Drawing of Rotary Pressure Vessel Test Apparatus

requirements for Thermometer 1C (1F), as prescribed in Specification E1 or thermocouple as summarized in Specification E230.

6. Reagents and Materials

6.1 *Purity of Reagents*—Reagent-grade chemicals shall be used in all tests. Unless otherwise specified, it is intended that all reagents conform to the specifications of the Committee on Analytical Reagents of the American Chemical Society where such specifications are available.³ Other grades may be used provided it is first ascertained that the reagent is of sufficiently high purity to permit its use without lessening the accuracy of the determination.

6.2 *Acetone*, reagent grade. (**Warning**—Flammable, health hazard.)

6.3 *Glacial Acetic Acid Concentrate*, reagent grade (**Warning**—Avoid contact with skin and eyes. Handle in a fume hood.)

6.4 *Hydrochloric Acid*, concentrated HCl (specific gravity (sp gr) 1.19) (**Warning**—HCl is a strong acid. Avoid contact with skin and eyes. Handle in a fume hood.)

6.5 *Isopropyl Alcohol*, reagent grade. (**Warning**—Flammable, health hazard.)

6.6 *Liquid Detergent*.

6.7 *n-Heptane*, 99.0 minimum mol% (pure grade). (**Warning**—Flammable, health hazard.)

6.8 *Nitric Acid*, HNO₃ 70% mass (**Warning**—HNO₃ is a strong toxic oxidant and acid. Avoid contact with skin, eyes, and clothing. Do not breathe vapor. Handle in a fume hood.)

6.9 *Oxygen*, 99.5 % with pressure regulation to 620 kPa (90 psi, 6.2 bar). (**Warning**—Vigorously accelerates combustion.)

6.10 *Potassium Hydroxide, Alcohol Solution (1 mass %)*—Dissolve 12 g of potassium hydroxide (KOH) pellets in 1 L of the isopropyl alcohol. (**Warning**—Flammable, health hazard.)

6.11 *Silicone Stopcock Grease*.

7. Test Specimens

NOTE 1—The specimens prescribed in this test method have been accepted by automobile manufacturers, but their composition may not be the same as that of alloys currently used for engine-cooling system components. Therefore, specimens other than those designated in this test method may be used by mutual agreement of the parties involved.

7.1 *Type*—The following metal test specimens,⁴ representative of cooling system metals, shall be used.

7.1.1 *Steel*—UNS G10200 (SAE 1020⁵) cut from 1.59-mm (1/16-in.) cold rolled sheet stock to size 50.8 by 25.4 mm (2 by 1 in.). Chemical composition of the carbon steel is as follows: carbon, 0.17 to 0.23 %, manganese; 0.30 to 0.60 %; phosphorus, 0.04 % maximum; sulfur, 0.05 % maximum.

7.1.2 *Copper*, conforming to UNS C11000 (SAE CA110) or UNS C11300 (SAE CA113). Cold rolled and cut from 1.59-mm (1/16-in.) sheet stock to size 50.8 by 25.4 mm (2 by 1 in.).

7.1.3 *Brass*, conforming to Alloy UNS C26000 (SAE CA 260). Half-hard, cut from 1.59-mm (1/16-in.) sheet stock to size 50.8 by 25.4 mm (2 by 1 in.).

³ *Reagent Chemicals, American Chemical Society Specifications*, American Chemical Society, Washington, DC. For suggestions on the testing of reagents not listed by the American Chemical Society, see *Analar Standards for Laboratory Chemicals*, BDH Ltd., Poole, Dorset, U.K., and the United States *Pharmacopeia and National Formulary*, U.S. Pharmacopeial Convention, Inc. (USPC), Rockville, MD.

⁴ Complete sets or individual metal test specimens are available from: (a) The Metaspac Company, P.O. Box 27707, San Antonio, TX 78227; or (b) Alabama Specialty Products, Inc., P.O. Box 8, Munford, AL 36268.

⁵ *UNIFIED Numbering System for Metals and Alloys*, SAE-ASTM, July 1995.

7.1.4 *Solder*—A brass specimen as described in 7.1.3 coated with solder conforming to Alloy Grade 30A (SAE 3A) of Specification B32.

7.1.5 *Cast Aluminum*, conforming to alloy UNS A23190 (SAE 329). Specimen size, 50.8 by 25.4 by 3.18 mm (2 by 1 by 1/8 in.).

7.1.6 *Cast Iron*, conforming to Alloy UNS F10007 (SAE G3500). Specimen size, 50.8 by 25.4 by 3.18 mm (2 by 1 by 1/8 in.).

7.2 *Arrangement*—See Fig. 2.

7.2.1 *Metal Specimen Arrangement*—None of the hardware used in the metal specimen arrangement (metal specimen, screws, insulating spacers, insulating sleeves, and nuts) can be reused for a test. The metal test specimens shall be drilled through the center with a 6.75-mm (1/4-in.) drill to accommodate a 41.28-mm (1 5/8-in.) 10-24 brass machine screw covered with a thin-walled insulating sleeve. Polytetrafluoroethylene tubing with a 6.35-mm (1/4-in.) outside diameter, width of 1.59-mm (1/16-in.), and a wall thickness of 0.4 mm (1/64-in.) is satisfactory. Two PTFE legs shall be cut from 1.59-mm (1/16-in.) PTFE sheet stock to size 50.80 by 28.58 mm (2 by 1 1/8 in.). A 6.35-mm (1/4-in.) diameter hole shall be drilled in each leg with the hole centered between 22.22 and 28.58 mm (7/8 and 1 1/8 in.) of the length and 14.28 mm (9/16 in.) from each side. The test “bundle” shall be made up on the insulated screw with the specimens in the following order: PTFE leg, copper, solder, brass, steel, cast iron, and cast aluminum, and PTFE leg. The specimens shall be separated by 3.18-mm (1/8-in.) insulating PTFE spacers having a 6.75-mm (1/4-in.) inside diameter and a 11.11-mm (7/16-in.) outside diameter. Insulating spacers are not to be used between the PTFE end legs and the copper and aluminum metal specimens. The bundle shall be firmly tightened together with the bolt and nut. Inspect the bundle to insure that there is not electrical connection between the metal specimens, center bolt, and nut. Inspect the bundle also to ensure that the PTFE legs extend past the metal specimens on the bottom and sides to minimize etching of the borosilicate glass container by the metal specimen bundle.

8. Preparation of Test Specimens

8.1 Sand the cast iron and cast aluminum specimens on the 25.4- by 50.8-mm (1- by 2-in.) cut surfaces with “coarse” grade (No. 1) emery cloth. Remove any burrs from coupon edges and hole. Scrub all specimens vigorously using a moistened bristle brush and ground pumice powder or fine silicon carbide grit until the entire metal area is bright, shiny, and free from any visible oxide film or tarnish.

8.2 Rinse the specimens thoroughly with tap water, then rinse with acetone, dry, and weigh to nearest 1 mg. Cast aluminum specimens should be dried in a 100°C (212°F) oven for 1 h to a constant weight before recording the weight.

NOTE 2—If the test specimens are not to be used immediately, keep them in a desiccator until required.

9. Test Solution

9.1 *Engine Coolant Test Fluid*—The engine coolant test fluid shall be prepared by mixing 50 vol % engine coolant concentrate with 50 vol % ASTM D1193 Type IV reagent water per ASTM D1176 preparation procedure. Pre-diluted / ready to use 50/50 coolants may also be used in this standard.

9.2 The engine coolant test fluid shall be tested before and after the test for physical properties and chemical properties (water/glycol content and pH; corrosion inhibitors: boron, nitrite, nitrate, molybdenum, phosphate, silicate, azoles, and other organic additive technology inhibitors; corrosion metals: aluminum, copper, iron, lead, and zinc; and coolant oxidation products: glycolates and formates).

10. Test Conditions

10.1 *Engine Coolant Test Fluid*—The test shall be run on a 55-mL sample of engine coolant test fluid per test.

10.2 *Test Gas and Temperature*—The test shall be conducted using either 1) air at 115°C (239°F) or 2) oxygen at 150°C (302°F). The temperature shall be maintained at ±2°C throughout the test.

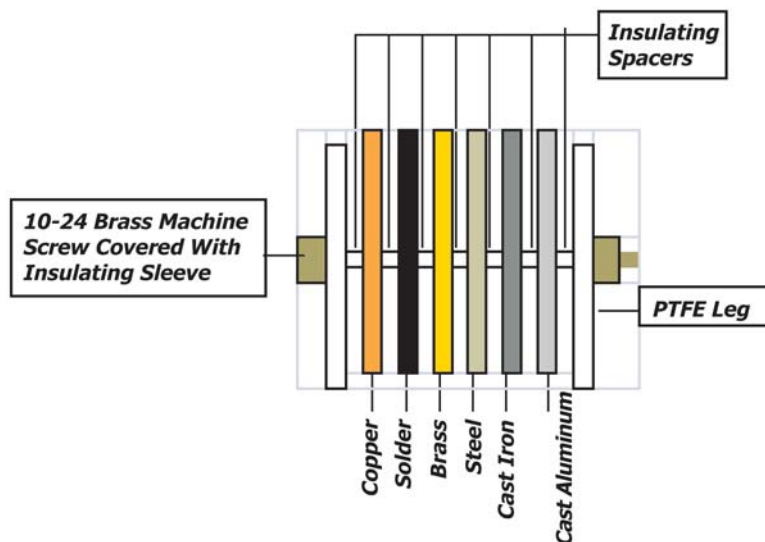

FIG. 2 Test Specimens Arrangement

10.3 *Rotary Pressure Vessel*—The rotary pressure vessel shall be charged with 620-kPa (90-psi) gas (oxygen or air) and rotated in the bath at 100 rpm at a 30° angle from horizontal.

10.4 *Test Duration*—The test shall be run continuously for one week (168 h).

11. Preparation of Apparatus

11.1 *Cleaning of Pressure Vessel*—Wash the pressure vessel body, cap, and inside vessel stem with hot detergent solution and rinse thoroughly with water. Rinse the inside of the stem with isopropyl alcohol and blow dry with compressed air. If the vessel body, cap, or inside of the stem exhibit any oxidation products residue or noticeable sour odor (oxidization odor), after the simple cleaning, wash with 1 mass % alcoholic KOH solution and repeat as before. Failure to remove oxidation residue can adversely affect test results.

11.2 *Cleaning of Glass Container*—Drain and rinse with a suitable solvent (for example, n-heptane or acetone). Soak or scrub in an aqueous detergent solution. Brush thoroughly and flush thoroughly with tap water. Rinse with isopropyl alcohol, followed by distilled water, and air dry. If any insolubles remain, soak overnight in a non-metal cleaning solution⁶ and repeat the above procedure starting from the tap water flush.

11.3 *Cleaning of PTFE Disks and End Legs*—Remove any residues from previous runs with a suitable solvent and clean by brushing with a detergent solution. Rinse thoroughly with tap water, followed by distilled water rinse, and air dry.

12. Procedure

12.1 *Charging*—Pour 55- ± 0.5-mL engine coolant test fluid into the glass container and place the metal specimen bundle in the glassware container. Add 5 mL of ASTM **D1193** Type IV reagent water to the pressure vessel body and slide the glass container into the pressure vessel body (see **Note 3**). Cover the glass container with a 57.2-mm (2¼-in.) PTFE disk and place a hold-down spring on top of the PTFE disk. Apply a thin coating of silicone stopcock grease or drop of ethylene glycol to the O-ring vessel seal located in the gasket groove of the vessel cap to provide lubrication and insert the cap into the vessel body.

NOTE 3—The water between the vessel wall and the sample container aids heat transfer.

12.2 Tighten the closure ring by hand. Cover the threads of the gage-nipple with a thin coating of stopcock grease (PTFE pipe tape is a suitable alternative to the use of stopcock grease) and screw the gage into the top center of the vessel stem. Attach the oxygen or air line with an inline pressure gage to the inlet valve on the vessel stem. Slowly turn on the oxygen or air supply valve until the pressure has reached 620 kPa (90 psi, 6.2 bar). Turn off the gas supply valve. Slowly release pressure by loosening the fitting or by using an inline bleeder valve. Repeat purging process two more times; the purge step should take approximately 3 min. Adjust the regulating valve on the gas supply tank to 620 kPa (90 psi, 6.2 bar) at a room temperature

of 25°C (77°F). For each 2.0°C (3.6°F) above or below this temperature, 5 kPa (0.7 psi, 0.05 bar) shall be added or subtracted to attain the required initial pressure. Fill the vessel to this required pressure and close the inlet valve securely by hand. If desired, test the vessel for leaks by immersing in water (see **Note 4**).

NOTE 4—If the vessel was immersed in water to check for leaks, dry the outside of the wet vessel by any convenient means such as air blast or a towel. Such drying is advisable to prevent subsequent introduction of free water into the hot oil bath which would cause spattering.

12.3 *Oxidation*—Insert the vessel into the carriage. Bring the heating bath to the test temperature while the stirrer is in operation. An auxiliary heater may be used to bring the bath up to test temperature. If an auxiliary heater is used, turn it off once the bath reaches test temperature. Start the test time when the bath reaches test temperature. Maintain the test temperature within ±2°C (see **Notes 5 and 6**).

NOTE 5—The time for the bath to reach the operating temperature after insertion of the vessel may differ for different apparatus assemblies and should be observed for each unit. The bath should reach test temperature within four hours. If laboratory safety procedures allow, the bath may be pre-heated to test temperature and the vessel then inserted in the bath. If this procedure is used, start the test once the vessel reaches test temperature (steady pressure) which is typically within 30 minutes of inserting the vessel.

NOTE 6—Maintaining the correct temperature within the specified limits of ±2°C during the entire test run is an important factor assuring both repeatability and reproducibility of the test results.

12.4 Keep the vessel completely submerged and maintain a continuous and uniform rotation speed of 100 ± 5 rpm for one week (168 h). Any appreciable variations in this speed could cause erratic results.

12.5 After termination of the test, the vessel shall be removed from the oil bath and cooled to room temperature. The vessel can be briefly dipped into and swirled around in a bath of light mineral oil to wash off the adhering bath oil. The vessel is rinsed off with hot water, then immersed into cold water to bring it quickly to room temperature. Alternately, the vessel can be cooled to room temperature in air. The excess oxygen or air pressure is bled off and the vessel opened.

12.6 Disassemble specimens and brush very lightly with a soft bristle brush and water to remove loosely held corrosion products. To remove the more tenacious corrosion products and films, the individual specimens shall then be subjected to additional cleaning treatments as:

12.6.1 *Iron and Steel*—Remove adherent deposits by means of a brass scraper or brass bristle brush followed by scrubbing with a wet bristle brush and fine pumice to clean the specimen completely.

12.6.2 *Copper and Brass*—Dip in a 1 + 1 mixture of concentrated hydrochloric acid (HCl) (sp gr of 1.19) and water for 15 s to remove tarnish films, rinse with tap water to remove acid, and scrub with a wet bristle brush and fine pumice powder. (**Warning**—HCl is a strong acid. Avoid contact with skin and eyes. Handle in a fume hood.)

12.6.3 *Aluminum*—In a fume hood, dip for 10 min in an aqueous solution containing four parts concentrated nitric acid (HNO₃, 70 mass %) plus one part distilled water at 25°C (76°F). Rinse thoroughly with water, then brush very lightly with a soft bristle brush to remove any loose films, and again

⁶ Nochromix or Micro 90 have been found to be satisfactory. An equivalent cleaner may be used.

rinse with water. Dry the specimen in a 100°C (212°F) oven for 1 h to a constant weight before recording the weight. (**Warning**—HNO₃ is a strong toxic oxidant and acid. Avoid contact with skin, eyes, and clothing. Do not breathe vapor. Handle in a fume hood.)

12.6.4 *Solder*—Immerse for 5 min in boiling 1 mass% glacial acetic acid. Rinse in water to remove the acid and brush very gently with a soft bristle brush to remove any loosened material. (**Warning**—Avoid contact with skin and eyes with glacial acetic acid. Handle in a fume hood.)

12.7 The acid dip times given in 12.6.2 – 12.6.4 for the cleaning of nonferrous specimens are average values found to be adequate in most cases. Other times, suggested by experience, may be used if necessary, if gross weight losses are adjusted by the appropriate tare.

12.8 Follow each of the four operations noted above by thorough rinsing, first in tap water and then in acetone. Then dry and weigh the specimens to the nearest 1 mg. Store in a desiccator specimens that cannot be weighed immediately.

12.9 Because cleaning methods and materials may vary among laboratories, occasionally determine cleaning losses obtained by a particular operator on an untested set of triplicate metal specimens. Deduct the average cleaning losses from gross weight differences to determine actual corrosion losses.

12.10 Remove the coolant from the glassware container. Test the engine coolant sample after the test for physical and chemical properties (water / glycol content and pH; corrosion inhibitors: boron, nitrite, nitrate, phosphate, silicate, organic additive technology additives, azoles; corrosion metals: aluminum, copper, iron, lead, and zinc; and glycol oxidation products: glycolates and formates). Test shall be considered suspect and voided if the engine coolant sample loses 4 % or more water because of pressure vessel malfunction (that is, loss of pressure).

13. Report

13.1 Report corrosion weight loss as a positive value and weight gain as a negative value. If no sign is given to the value, it will be interpreted as a weight loss.

13.1.1 *Example*—Initial weight of a brass specimen after cleaning was 405 mg. At the end of test after cleaning it was 398 mg. Using Eq 2, calculate the weight change of the specimen.

(Initial weight – end of test weight) – (Cleaning blank – cleaning blank recleaned alongside of end of test specimen) = Final reported weight change

$$405 \text{ mg} - 398 \text{ mg} - (406 \text{ m g} - 404 \text{ m g}) = 5 \text{ mg} \quad (2)$$

(positive value means that it is a weight loss)

13.2 Report the corrosion weight changes of individual specimens to the nearest 1 mg for each test.

13.3 Report coolant physical and chemical properties before and after the test. The report summarizing the test results should include the following information: digital images of the coolant and coupons (wiped dry) immediately after test, metal coupon weight changes, coolant dilution, pH values, corrosion inhibitor levels (boron, nitrite, nitrate, phosphate, silicate, organic additive technology additives, andazole inhibitors), corrosion metals (aluminum, copper, iron, lead, and zinc), and glycol oxidation products (glycolates and formates).

14. Precision and Bias

14.1 As indicated in 4.1, this test method is intended only as a rough screening tool. Combination oxidation and corrosion tests of this type are inherently lacking in precision and bias, and specific weight change values for metal specimens cannot be interpreted closely. Repeatability and reproducibility limits are currently under development.

14.2 *Bias*—Since there is no accepted reference material for determining the bias for the procedure in this method, bias has not been determined.

15. Keywords

15.1 accelerated aging; corrosion; engine coolants; oxidation stability

ANNEX

(Mandatory Information)

A1. APPARATUS

A1.1 *Oxidation Vessel*, with body, cap, closure ring, and stem, constructed as shown in Figs. A1.1 and A1.2.

A1.1.1 *Vessel Body and Cap* shall be constructed of 18-8 stainless steel to ensure a proper rate of heat transfer. The interior surface shall be given a smooth finish to facilitate cleaning. Alternatively, the vessel body and cap may be

machined from 76.2-mm (3-in.) solid copper rod and then heavily chrome plated.

A1.1.2 *Vessel Stem* shall be constructed of stainless steel with the stem having an inside diameter of 6.4 mm (¼ in.) and shall be equipped with a 6.4-mm (¼-in.) needle valve.

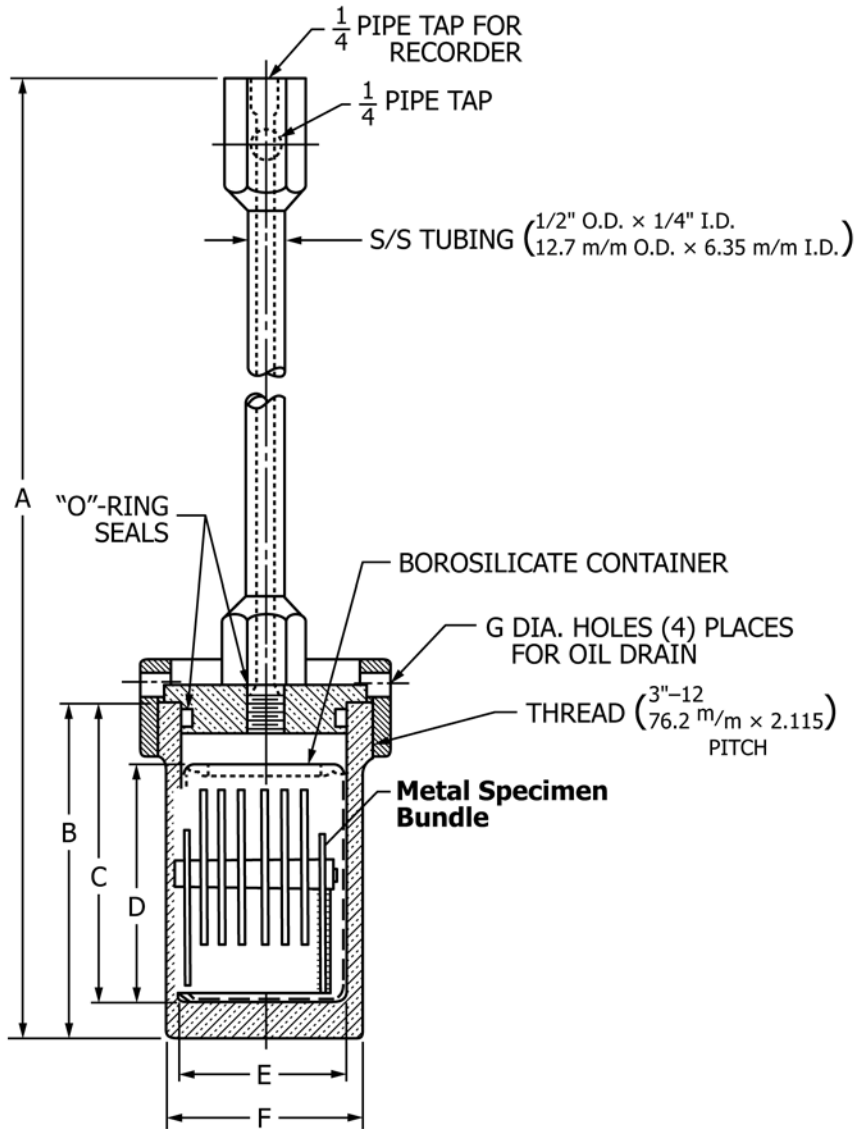

FIG. A1.1 Oxidation Vessel

A1.1.3 *Closure Ring* shall be made of chrome-plated steel or chrome-plated aluminum bronze BS 2032.

A1.1.4 The vessel shall withstand a working pressure of 3450 kPa (500 psi, 34.5 bar) at 150°C (302°F). (**Warning**—Pressure vessel and bath must be in compliance with user’s health, safety, and environment regulations for use of high pressure equipment.)

A1.1.5 *O-Ring Gaskets*, Fluoroelastomer (FKM) or silicone (VMQ), 50.8 mm (2 in.) in inside diameter by 60.3 mm (2³/₈ in.) in outside diameter (BS/USA size No. 329). Caps with larger seal recess diameters will require 54-mm (2¹/₈-in.) inside diameter by 60.3-mm (2³/₈-in.) outside diameter (BS/USA size No. 227).

A1.2 *Glass Sample Container*, 175-mL capacity as shown in Fig. A1.3, constructed of borosilicate glass. The glass sample container shall have a sliding fit in the vessel with no

excess side clearance. The container alone shall have a maximum wall thickness of 2.5 mm and shall weigh no more than 100 g.

A1.2.1 *Top of Sample Container* shall be covered with 57.2-mm (2¹/₄-in.) diameter PTFE disk. The disk will have four 3.2-mm (1/8-in.) diameter holes evenly spaced in a 9.5-mm (3/8-in.) radius from the center of the disk. The disk shall have a thickness of 1.6 mm (1/16 in.). A stainless steel hold-down spring as shown in Fig. A1.4 shall be used to ensure rotation of the sample container. The assembly is shown in Fig. A1.5.

A1.3 Recording Devices

A1.3.1 *Pressure Measurement System*, consisting of electronic pressure transducers, power source, mounting equipment, and connecting cables. The rotary transducer couplings can be mounted directly on the vessel stem in place of the standard mechanical pressure recorders. The pressure

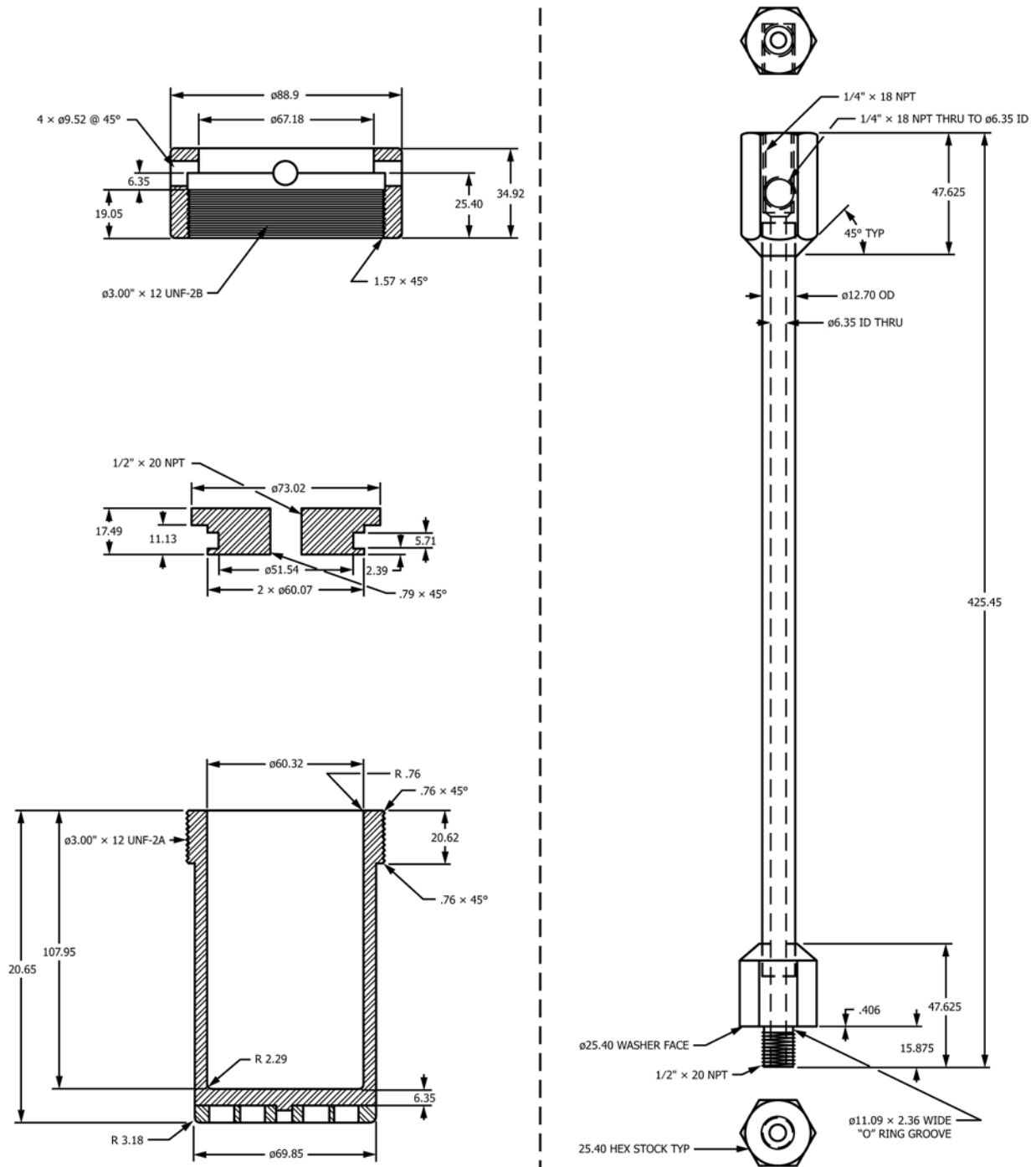

FIG. A1.2 Construction of Oxidation Vessel

transducer shall have a span of 0 to 1400 kPa (or 0 to 200 psi or 0 to 14 bar). The accuracy should be valid over a wide compensated temperature range. The output signal from the transducer can be channeled into a data logger, microprocessor-based recorder, or a computer for data acquisition. The data acquisition package should be capable of logging pressure data vessel time. The overall system accuracy of the data should be within 2.5 % of the total scale.

A1.4 *Oxidation Bath*, equipped with an efficient stirrer and a suitable device from holding and rotating the vessel axially at

an angle of 30° at $100 \pm 5 \text{ rpm}$ while submerged in oil to a point at least 25 mm (1 in.) below the level of the bath liquid.

A1.4.1 A bath at least 230 mm (9 in.) deep, filled with 30 L (8 gal) of heavy bath oil per vessel, has the proper heat capacity. Silicone oil has been found to perform satisfactorily as a bath fluid. The oil bath should be placed under a fume hood or be equipped with a vent pipe to contain any oil vapors generated.

A1.4.2 Provide thermal regulation to maintain the bath within 1°C of the test temperature. There should be sufficient,

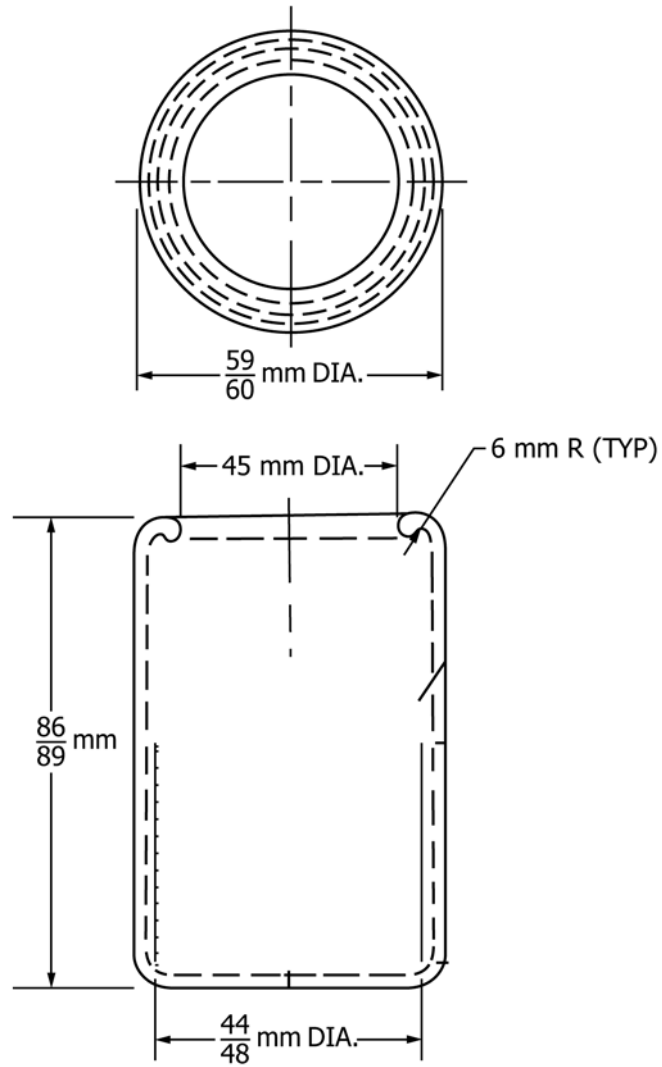
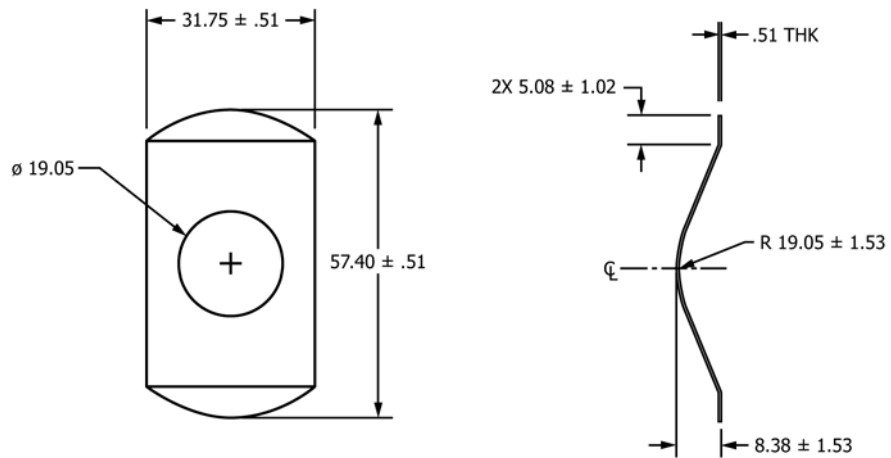

FIG. A1.3 Borosilicate Glass Sample Container



All dimensions are in millimeters
 Unless otherwise specified tolerance is ± .13

FIG. A1.4 Hold-Down Spring (bottom)

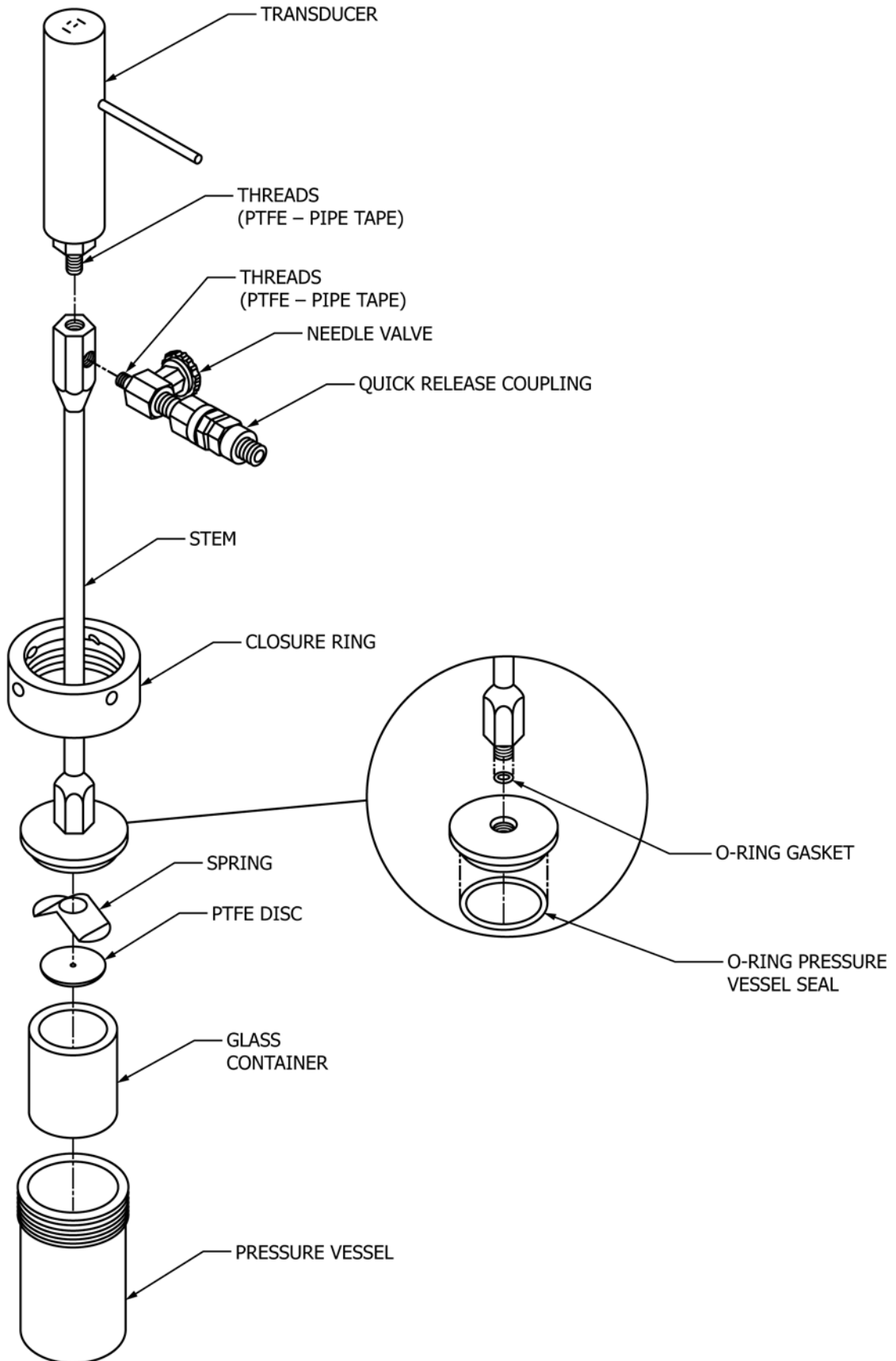
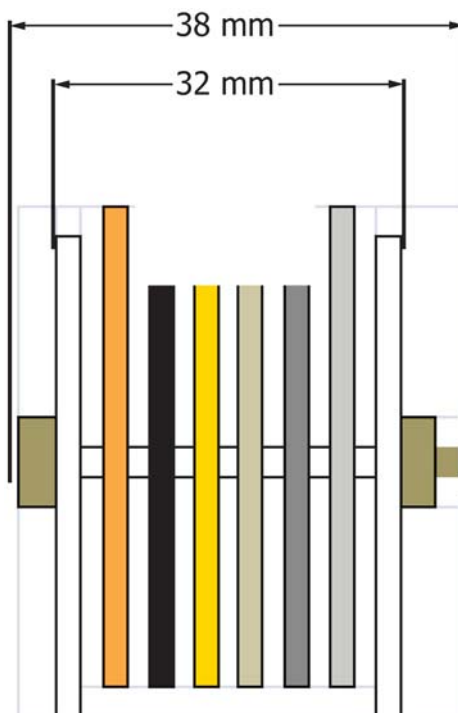

FIG. A1.5 Oxidation Vessel Assembly



NOTE 1—Specimen bundle includes 3.18-mm (one 1/8-in. or two 1/16-in.) PTFE spacers between metal specimens. Spacers are not used between the legs and end metal specimens (aluminum and copper) of the bundle. PTFE legs shall extend 6.35 mm (1/4 in.) below and 1.59 mm (1/16 in.) on both sides of the metal specimen bundle to prevent etching of the metal specimen bundle against the borosilicate glass sample container. Specimen is held together using a 41.28-mm (1 5/8-in.) 10-24 brass machine screw covered with a thin-walled insulating sleeve. Polytetrafluorethylene tubing with a 6.35-mm (1/4-in.) outside diameter, width of 1.59 mm (1/16 in.), wall thickness of 0.40 mm (1/64 in.), and length of 31.75 mm (1 1/4 in.) is suitable.

FIG. A1.6 Metal Specimen Bundle Dimensions

immediately available heat to bring the bath to operating temperature within 15 min after the vessels have been inserted. The thermal regulation shall include over temperature shut down.

A1.5 *Thermometer*, IP 37C sludge test thermometer having a range from 144 to 156°C graduated in 0.2°C intervals or alternative temperature-measuring devices, having an accuracy of 0.1°C.

A1.6 *Gage*, for pressurizing vessel to 620 kPa (90 psi) graduated in 1.5-kPa (0.2-psi) increments.

ASTM International takes no position respecting the validity of any patent rights asserted in connection with any item mentioned in this standard. Users of this standard are expressly advised that determination of the validity of any such patent rights, and the risk of infringement of such rights, are entirely their own responsibility.

This standard is subject to revision at any time by the responsible technical committee and must be reviewed every five years and if not revised, either reapproved or withdrawn. Your comments are invited either for revision of this standard or for additional standards and should be addressed to ASTM International Headquarters. Your comments will receive careful consideration at a meeting of the responsible technical committee, which you may attend. If you feel that your comments have not received a fair hearing you should make your views known to the ASTM Committee on Standards, at the address shown below.

This standard is copyrighted by ASTM International, 100 Barr Harbor Drive, PO Box C700, West Conshohocken, PA 19428-2959, United States. Individual reprints (single or multiple copies) of this standard may be obtained by contacting ASTM at the above address or at 610-832-9585 (phone), 610-832-9555 (fax), or service@astm.org (e-mail); or through the ASTM website (www.astm.org). Permission rights to photocopy the standard may also be secured from the Copyright Clearance Center, 222 Rosewood Drive, Danvers, MA 01923, Tel: (978) 646-2600; http://www.copyright.com/