



Standard Test Method for Determination of Fracture Toughness of Graphite at Ambient Temperature¹

This standard is issued under the fixed designation D7779; the number immediately following the designation indicates the year of original adoption or, in the case of revision, the year of last revision. A number in parentheses indicates the year of last reapproval. A superscript epsilon (ϵ) indicates an editorial change since the last revision or reapproval.

1. Scope

1.1 This test method covers and provides a measure of the resistance of a graphite to crack extension at ambient temperature and atmosphere expressed in terms of stress-intensity factor, K , and strain energy release rate, G . These crack growth resistance properties are determined using beam test specimens with a straight-through sharp machined V-notch.

1.2 This test method determines the stress intensity factor, K , from applied force and gross specimen deflection measured away from the crack tip. The stress intensity factor calculated at the maximum applied load is denoted as fracture toughness, K_{Ic} , and is known as the critical stress intensity factor. If the resolution of the deflection gauge is sensitive to fracture behavior in the test specimen and can provide a measure of the specimen compliance, strain energy release rate, G , can be determined as a function of crack extension.

1.3 This test method is applicable to a variety of grades of graphite which exhibit different types of resistance to crack growth, such as growth at constant stress intensity (strain energy release rate), or growth with increasing stress intensity (strain energy release rate), or growth with decreasing stress intensity (strain energy release rate). It is generally recognized that because of the inhomogeneous microstructure of graphite, the general behavior will exhibit a mixture of all three during the test. The crack resistance behavior exhibited in the test is usually referred to as an “R-curve.”

NOTE 1—One difference between the procedure in this test method and test methods such as Test Method E399, which measure fracture toughness, K_{Ic} , by one set of specific operational procedures, is that Test Method E399 focuses on the start of crack extension from a fatigue precrack for metallic materials. This test method for graphite makes use of a machined notch with sharp cracking at the root of the notch because of

the nature of graphite. Therefore, fracture toughness values determined with this method may not be interchanged with K_{Ic} as defined in Test Method E399.

1.4 This test method gives fracture toughness values, K_{Ic} and critical strain energy release rate, G_{Ic} for specific conditions of environment, deformation rate, and temperature. Fracture toughness values for a graphite grade can be functions of environment, deformation rate, and temperature.

1.5 This test method is divided into two major parts. The first major part is the main body of the standard, which provides general information on the test method, the applicability to materials comparison and qualification, and requirements and recommendations for fracture toughness testing. The second major part is composed of annexes, which provide information related to test apparatus and test specimen geometry.

	Main Body	Section
Scope		1
Referenced Documents		2
Terminology		3
Summary of Test Method		4
Significance and Use		5
Apparatus		6
Test Specimen		7
Procedure		8
Specimen Dryness		9
Calculation of Results		10
Report		11
Precision and Bias		12
Keywords		13
Annex		Annex A1

1.6 The values stated in SI units are to be regarded as standard. No other units of measurement are included in this standard.

1.6.1 Measurement units expressed in these test methods are in accordance with IEEE/ASTM SI 10.

1.7 This standard does not purport to address all of the safety concerns, if any, associated with its use. It is the responsibility of the user of this standard to establish appropriate safety and health practices and determine the applicability of regulatory limitations prior to use.

¹ This test method is under the jurisdiction of ASTM Committee D02 on Petroleum Products, Liquid Fuels, and Lubricants and is the direct responsibility of Subcommittee D02.F0 on Manufactured Carbon and Graphite Products.

Current edition approved June 1, 2015. Published July 2015. Originally approved in 2011. Last previous edition approved in 2011 as D7779 – 11. DOI:10.1520/D7779-11R15.

2. Referenced Documents

2.1 ASTM Standards:²

- C709** Terminology Relating to Manufactured Carbon and Graphite
- C1161** Test Method for Flexural Strength of Advanced Ceramics at Ambient Temperature
- C1421** Test Methods for Determination of Fracture Toughness of Advanced Ceramics at Ambient Temperature
- E4** Practices for Force Verification of Testing Machines
- E177** Practice for Use of the Terms Precision and Bias in ASTM Test Methods
- E337** Test Method for Measuring Humidity with a Psychrometer (the Measurement of Wet- and Dry-Bulb Temperatures)
- E399** Test Method for Linear-Elastic Plane-Strain Fracture Toughness K_{Ic} of Metallic Materials
- E561** Test Method for **K-R** Curve Determination
- E691** Practice for Conducting an Interlaboratory Study to Determine the Precision of a Test Method
- E1823** Terminology Relating to Fatigue and Fracture Testing
- E2309** Practices for Verification of Displacement Measuring Systems and Devices Used in Material Testing Machines
- IEEE/ASTM SI 10** Standard for Use of the International System of Units (SI) (The Modern Metric System)

3. Terminology

3.1 Definitions:

3.1.1 The terms described in Terminology **C709** and **E1823** are applicable to the test methods prescribed herein. Appropriate sources for each definition are provided after each definition in parentheses.

3.1.2 *crack extension resistance*, $K_R[FL^{-3/2}]$, $G_R[FL^{-1}]$, or $J_R[FL^{-1}]$, n —measure of the resistance of a material to crack extension expressed in terms of the stress-intensity factor, K , strain energy release rate, G , or values of J derived using the J-integral concept. **E1823**

3.1.3 *R-curve*, n —plot of stress intensity or strain energy release rate as a function of stable crack extension and provides a measure of crack propagation trend in the material. **E561**

3.1.4 *slow crack growth*, (*SCG*), n —sub-critical crack growth (extension) which may result from, but is not restricted to, such mechanisms as environmentally-assisted stress corrosion or diffusive crack growth, usually at constant load.

3.1.5 *stress-intensity factor*, $K[FL^{-3/2}]$, n —magnitude of the ideal-crack-tip stress field (stress field singularity) for a particular mode in a homogeneous, linear-elastic body. **E1823**

3.2 Definitions of Terms Specific to This Standard:

3.2.1 *crack depth*, $a[L]$, n —length of the crack in a notched beam specimen, which includes the machined notched length and the crack length which the crack has traveled during testing. Any contributions from crack branching or other secondary cracking are not included in this measurement.

3.2.2 *crack extension orientation*, n —direction of propagation in relation to a characteristic direction of the graphite specimen. This identification may be designated by a letter or letters indicating the plane and direction of crack extension. The letter or letters represent the direction normal to the crack plane and the direction of crack propagation.

3.2.2.1 *Discussion*—The characteristic direction should be associated with the microstructural grain orientation of the test specimen.

3.2.2.2 *Discussion*—The crack plane can be defined by letter(s) representing the direction of tensile stress normal to the crack plane. And the direction of crack extension can be defined by letter(s) representing the direction parallel to the characteristic grain orientation of the test specimen. As illustrated in **Annex A1**, the tensile stress direction is notated first, followed by a hyphen, and then the crack extension direction. The legend given in Test Methods **C1421** includes the following:

- M = molding direction
- EX = extrusion direction
- AXL = axial, or longitudinal axis (if M or EX are not applicable)
- R = radial direction
- C = circumferential direction
- R/C = mixed radial and circumferential directions

3.2.2.3 *Discussion*—For a graphite test specimen of rectangular cross section, R and C may be replaced by rectilinear coordinate axes, x and y , corresponding to two adjacent sides of the test specimen.

3.2.2.4 *Discussion*—Depending on how test specimens are cut from a graphite product, the crack plane may be longitudinal to the forming direction, or circumferential, or radial, or a mixture of these directions as shown in **Annex A1**.

3.2.2.5 *Discussion*—For the test specimen the plane and direction of crack extension with respect to the applied tensile stress should be recorded. Report the orientation of the specimen and crack propagation direction with respect to the grain direction.

3.2.2.6 *Discussion*—If there is no primary product direction, reference axes may be arbitrarily assigned but must be clearly identified.

3.2.3 *critical crack depth*, $[L]$, n —crack depth at which catastrophic fracture initiation occurs, corresponding to the maximum in the applied load.

3.2.4 *fracture toughness*, $K[FL^{-3/2}]$, n —property which defines the critical stress intensity factor necessary to initiate a crack for subsequent propagation on further loading.

3.2.5 *small crack*, n —being small when all physical dimensions (in particular, with length and depth of a surface crack) are small in comparison to a relevant microstructural scale, continuum mechanics scale, or physical size scale. The specific physical dimensions that define “small” vary with the particular material, geometric configuration, and loadings of interest. **E1823**

3.2.6 *stable crack extension*, n —crack propagation which provides measurable data of the dependence of stress intensity

² For referenced ASTM standards, visit the ASTM website, www.astm.org, or contact ASTM Customer Service at service@astm.org. For *Annual Book of ASTM Standards* volume information, refer to the standard’s Document Summary page on the ASTM website.

factor on crack extension and which occurs over some measurable time duration.

3.2.7 *three-point flexure, n*—flexure configuration where a beam test specimen is loaded at a location midway between two support bearings. **C1161**

3.2.8 *unstable crack extension*—uncontrollable crack propagation which yields no measurable data of the dependence of stress intensity factor on crack extension.

3.3 Symbols:

3.3.1 a —crack depth, including the machined notch (see Fig. 1).

3.3.2 a/W —normalized notch depth.

3.3.3 B —the specimen width (see Fig. 1).

3.3.4 $g(a/W)$ —geometric function of the ratio a/W .

3.3.5 L —test specimen length (see Fig. 1).

3.3.6 P —force.

3.3.7 P_{max} —maximum force.

3.3.8 S —support span (see Fig. A1.2).

3.3.9 W —the specimen depth (see Fig. 1).

4. Summary of Test Method

4.1 This test method involves an application of force to a beam test specimen in three-point flexure. The test specimen contains a straight-through notch in the center. The equations for calculating the fracture toughness have been established on the basis of linear-elastic stress analyses.

4.2 *Notched Beam Method*—A straight-through notch is machined in a beam test specimen. The applied force on the notched test specimen as a function of time and actuator displacement or specimen deflection in three-point flexure, or a combination thereof, are recorded for analysis. The fracture toughness, K_{Ic} , is calculated from the maximum (fracture) force, the test specimen dimensions, the measured notch depth, and the support span of the test fixture. Calculation of strain energy release rate, G , requires a determination of specimen compliance, and crack length at each load point of the load versus displacement curve. The maximum G derived from the strain energy release rate versus crack growth curve is recorded.

5. Significance and Use

5.1 This test method may be used for guidance for material development to improve toughness, material comparison, quality assessment, and characterization.

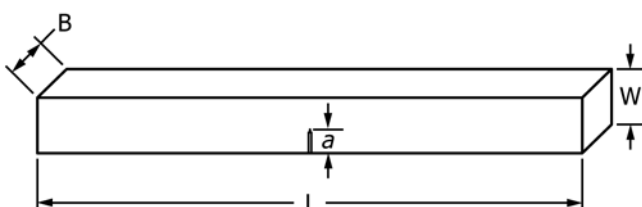

FIG. 1 Specimen Dimension (see 3.3)

5.2 The fracture toughness value provides information on the initiation of fracture in graphite containing a straight-through notch; the information on stress intensity factor beyond fracture toughness as a function of crack extension provides information on the crack propagation resistance once a fracture crack has been initiated to propagate through the test specimen.

6. Apparatus

6.1 *Testing*—Test the specimens in a testing machine that has provisions for autographic recording of force applied to the test specimen versus time and actuator displacement or deflection of the specimen, or both, in the notch plane. The testing machine shall conform to the requirements of Practice E4.

6.2 *Deflection Measurement*—The deflection gauge should be capable of resolving 0.001 mm. Practices E2309 cover procedures and requirements for the calibration and verification of displacement measuring systems.

6.3 *Recording Equipment*—Provide digital data acquisition for automatically recording the applied force versus displacement.

6.4 *Fixtures*—Use a three-point test fixture constructed with high stiffness materials (see Fig. A1.2). Choose the outer support span, S , such that $5 \leq (S/W) \leq 10$. The outer two rollers shall be free to roll outwards from support locations to minimize friction effects. The middle flexure roller shall be fixed. The specimen should overhang each of the outer rollers by a minimum distance equal to the specimen dimension, W .

6.5 *Dimension-Measuring Devices*—Measure and report all applicable specimen dimensions to an accuracy of 0.013 mm. Flat, anvil-type micrometers shall be used for measuring test specimen dimensions. Ball-tipped or sharp-anvil micrometers are not recommended as they may damage the test specimen surface by inducing localized cracking. Non-contacting (for example, optical comparator, light microscopy, etc.) measurements are recommended for notch depth measurements. Measure and report the notch depth to an accuracy of 0.0025 mm.

7. Test Specimen

7.1 *Test Specimen Configuration*—The specimen shall have a straight-through machined V-notch with a maximum notch root radius of 0.10 mm. The notch may be sharpened by drawing an industrial razor blade or similar device across the notch tip to encourage stable crack extension from the as-machined notch tip.

7.1.1 The included angle of the razor blade edge should be less than the specimen notch angle. It is recommended that the sharpening process be controlled such that this step is made in a consistent, measurable manner across the width of the notch. Manual sharpening introduces uncertainty in the initial notch depth and may also cause premature failure.

7.1.2 The ease with which a crack initiates from a machined notch depends on both the width of the notch, particularly the notch tip asperity, and the average grain size of the material under consideration. Because typical graphite grades contain 10 percent to 20 percent porosity, and the graphite grains have Morowski microcracks within them, it is expected that the

initiation of a “natural” crack with a narrow width is likely, thus avoiding the need to initiate a fatigue crack in graphite for fracture toughness determination.

7.2 Test Specimen Dimensions—The recommended test specimen configuration is given in Fig. A1.3 and has a 15 mm by 20 mm rectangular cross section with a machined notch in the center of the specimen long dimension, with the depth of the machined notch as 40 % of the specimen depth. Other specimen sizes with the same scaling may be used in order to sample an adequate quantity of pores and grains of various graphite grades. Specimen size/volume should reflect graphite structure. As a minimum recommendation, dimensions in the notch plane should be 5 to 10 times the maximum particle size of the graphite. The user of this test method must be satisfied with appropriate technical basis that the ratio of the notch size to graphite grain size does not affect the test results.

7.3 Test Specimen Preparation—Test specimens shall be prepared with flat, parallel and perpendicular surfaces (see Fig. A1.3) using conventional tooling which eliminates grain pull-out and variable surface roughness. Dry-machining of the specimens, using no liquid coolant medium, should be preferred. The center notch shall be machined with a contoured slitting saw with the narrowest width, consistent with the graphite grade under examination.

8. Procedure

8.1 Number of Tests—A minimum of six valid tests shall be conducted.

8.2 Valid Tests—A valid individual test is one which meets all the following requirements:

8.2.1 Test machine shall have provisions for autographic recording of force versus deflection, and the test machine shall have accuracy in accordance with Practice E4.

8.2.2 Test fixtures shall comply with specifications of 6.4.

8.2.3 Dimension-measuring devices shall comply with specifications of 6.5.

8.2.4 Test specimens shall be aligned to comply with the requirements specified in 8.5.

8.2.5 The recommended specimen loading rate is 0.1 mm/min. Deviation from this displacement rate should be reported since fracture toughness behavior can be sensitive to loading rate.

8.3 Test Specimen Measurements—Measure and report all applicable test specimen dimensions to three decimal places. For a valid test, the dimensions shall conform to the tolerances provided in Fig. A1.3.

8.4 Test Specimen Alignment—Place the test specimen in the three-point flexure fixture with the notch down and in the center of the support span and in alignment directly under the loading roller. Align the notch plane of the specimen as well as the axis of central roller of the test fixture directly in line with the axis of the test system load cell.

8.4.1 Three-Point Flexure—The plane of the notch shall be centered under the central roller to within 0.5 mm. Measure the span to within 0.5 % of the span width, S . Align the center of the middle roller such that its line of action shall pass midway between the two outer rollers to within 0.1 mm. Position the

displacement indicator gage as close to the crack plane as possible. Alternatively, use actuator (or crosshead) displacement or a time sweep.

8.5 Force Measurement—Measure force during the test duration and record the maximum force (at crack initiation) as P_{max} .

8.6 Humidity—Measure the temperature and humidity according to Test Method E337.

9. Specimen Dryness

9.1 It has been observed that the ambient moisture content could affect the mechanical properties of graphite. Test specimens may be dried to reduce moisture content to a consistent low level. This can be achieved by drying the test specimens in a vented oven at 110 °C to 150 °C for a period of 2 h. The specimens should then be held in a dry environment and removed just prior to fracture toughness testing.

10. Calculation of Results

10.1 Fracture Toughness, K_{Ic} :

10.1.1 The load-displacement curve for a test specimen can exhibit stable, quasi-stable, unstable crack growth resistance characteristic. Typically, a combination of these types of cracking can be observed during a test (see Fig. 2).

10.1.2 The possible presence of nonlinearity in the initial part of the applied force displacement curve is usually an artifact of the test setup and may not be indicative of material behavior.

10.1.3 For a three-point flexure with $5 \leq S/W \leq 10$, and $0.35 \leq a/W \leq 0.60$, calculate the fracture toughness, K_{Ic} , using Eq 1:

$$K_{Ic} = g \left[\frac{P_{max} S 10^{-6}}{B W^{3/2}} \right] \left[\frac{3[a/W]^{1/2}}{2[1 - a/W]^{3/2}} \right] \quad (1)$$

where:

$g = g(a/W)$, and

$g = A_0 + A_1(a/W) + A_2(a/W)^2 + A_3(a/W)^3 + A_4(a/W)^4 + A_5(a/W)^5$

10.1.4 The coefficients for the factor, g , are shown Table 1.

where:

K_{Ic} = fracture toughness (MPa√m),

$g = g(a/W)$ = function of the ratio a/W ,

P_{max} = maximum force (N),

S = support span (m),

B = breadth (width) of the specimen (m) (see Fig. A1.2),

W = specimen depth (m) (see Fig. A1.2), and

a = notch depth (m).

10.2 Strain Energy Release Rate, G :

10.2.1 Determination of strain energy release rate requires load versus displacement data.

10.2.2 Following the initial nonlinearity at the start of the test, the load-displacement diagram for notched beam specimens is characterized by a linear relationship. The data then deviate from a straight line when crack propagation occurs.

10.2.3 The first step in determination of G is to produce a straight line plot for the initial portion of the load-displacement

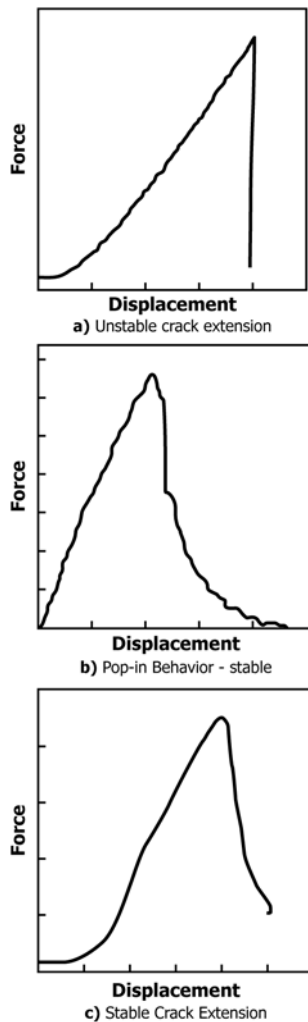

FIG. 2 Load-Displacement Behavior from Notched Beam Tests

TABLE 1 Coefficients for the Polynomial $g(a/W)$

NOTE 1—If the support span of the test fixture lies between two values in the table above, linear interpolation may be used to determine the coefficients.

	S/W				
	5	6	7	8	10
A ₀	1.9109	1.9230	1.9322	1.9381	1.9472
A ₁	-5.1552	-5.1389	-5.1007	-5.0947	-5.0247
A ₂	12.6880	12.6194	12.3621	12.3861	11.8954
A ₃	-19.5736	-19.5510	-19.0071	-19.2142	-18.0635
A ₄	15.9377	15.9841	15.4677	15.7747	14.5986
A ₅	-5.1454	-5.1736	-4.9913	-5.1270	-4.6896

diagram. Data clearly lying in the linear portion of the diagram are fitted to an equation of the form:

$$y = mx + b$$

The intersection of the fitted line with the abscissa establishes a new origin for the load displacement diagram, and the fitted line is expressed as:

$$y = mx$$

For each data point, n , the originally measured displacement must be adjusted to account for the newly established origin (zero).

10.2.4 The beginning of crack propagation is considered to be the point where displacement departs from the calculated linear line by 0.002 mm.

10.2.5 The compliance for each data point, C_n , is defined as the inverse of the slope of a line from the newly established origin of the load (P)-displacement (D) diagram to the given data point, n :

$$C_n = D_n / P_n \quad (2)$$

where:

C_n = compliance for the point n (m/N),
 D_n = displacement for the point n (m), and
 P_n = loading force for the point n (N).

10.2.6 Determine the crack length, a_n , associated with each data point along the P-D diagram.

10.2.7 The initial crack length, a_0 , for the notched beam specimen is the notch depth, a .

$$a_n = a_{n-1} + [(W - a_{n-1})/2 * ((C_n - C_{n-1})/C_{n-1})] \quad (3)$$

(The crack length remains unchanged along the initial linear portion of the P-D diagram.)

10.2.8 Determine the strain energy release rate, $G(a_n)$ [J/m²], for each data point.

$$G(a_n) = P^2 / 2B * \delta C / \delta a \quad (4)$$

where:

δC = $(C_n - C_{n-1})$, and
 δa = $(a_n - a_{n-1})$.

10.2.9 Plot $G(a_n)$ versus crack growth extension, Δa .

where:

$$\Delta a = a_n - a_0.$$

10.2.10 Report the strain energy release rate, G . The G versus Δa plot initially exhibits an increase in G as the crack propagates. The strain energy release rate may reach a plateau indicating steady state crack propagation, or tend to decrease with further crack extension. If there is upward inflection in the G versus Δa curve as the specimen nears failure with a maximum occurring at failure, report the initial peak in G as the maximum strain energy release rate, G_{Ic} , for that particular test result.

11. Report

11.1 For each test specimen, report the following information:

11.1.1 Test specimen identification,

11.1.2 Type and class of graphite tested, and materials processing information,

11.1.3 Mean and maximum grain size, or both,

11.1.4 Test environment, including relative humidity and temperature, and crack propagation direction with respect to grain orientation and the tensile stress direction,

11.1.5 Test specimen dimensions: L, B, and W,

11.1.6 Crack length, a , notch width and as-machined tip radius, and the method used for sharpening the root of the machined notch,

11.1.7 Test fixture description,

11.1.8 Support span, S,

- 11.1.9 Crosshead or actuator speed,
- 11.1.10 Maximum test force, P_{max} ,
- 11.1.11 Force versus displacement diagrams to report unstable crack extension, pop-in behavior, or smooth, stable crack extension,
- 11.1.12 Number of specimens tested, and the number of valid tests,
- 11.1.13 Fracture toughness, K_{Ic} , and critical strain energy release rate, G_{Ic} values for each test specimen,
- 11.1.14 Mean and standard deviation for K_{Ic} , and
- 11.1.15 Mean and standard deviation for G_{Ic} .

12. Precision and Bias³

12.1 An interlaboratory study was conducted in which test specimens of three graphite grades were tested to determine fracture toughness, K_{Ic} , and strain energy release rate, G_{Ic} by this test method. Validated results from six laboratories were analyzed following Practice E691. Generally, each participant provided six or ten valid test results for each material. Details of the analysis are given in ASTM Research Report.³

12.1.1 The precision information given here for fracture toughness, K_{Ic} , is for the comparison of three test results, each the average of nine to ten test determinations.

Material	PGX	R4650	S2020
Average test value [MPa√m]	0.7821	1.065	1.006
95 % repeatability limit (within laboratory) [MPa√m]	0.1417	0.0380	0.1253
95 % reproducibility limit (between laboratory) [MPa√m]	0.1420	0.0824	0.1253

³ Supporting data pending being filed at ASTM International Headquarters.

12.1.2 The precision information given here for critical strain energy release rate, G_{Ic} , is for the comparison of the same materials, each the average of five to ten test determinations.

Material	PGX	R4650	S2020
Average test value [J/m ²]	221.281	70.961	56.89
95 % repeatability limit (within laboratory) [J/m ²]	45.859	12.035	36.596
95 % reproducibility limit (between laboratory) [J/m ²]	56.387	35.651	47.117

12.1.3 The terms “reproducibility limit” and “repeatability limit” are used as specified in Practice E177. The respective standard deviations among the test results may be obtained by dividing the above limit values by 2.8.

12.2 *Bias*—No statement on bias can be made since values of the fracture toughness and the critical strain energy release rate for standard graphite materials have not been established.

13. Keywords

13.1 fracture toughness; graphite; notched beam; strain energy release rate; three-point bend

ANNEX

(Mandatory Information)

A1. FIGURES

See Figs. A1.1-A1.3.

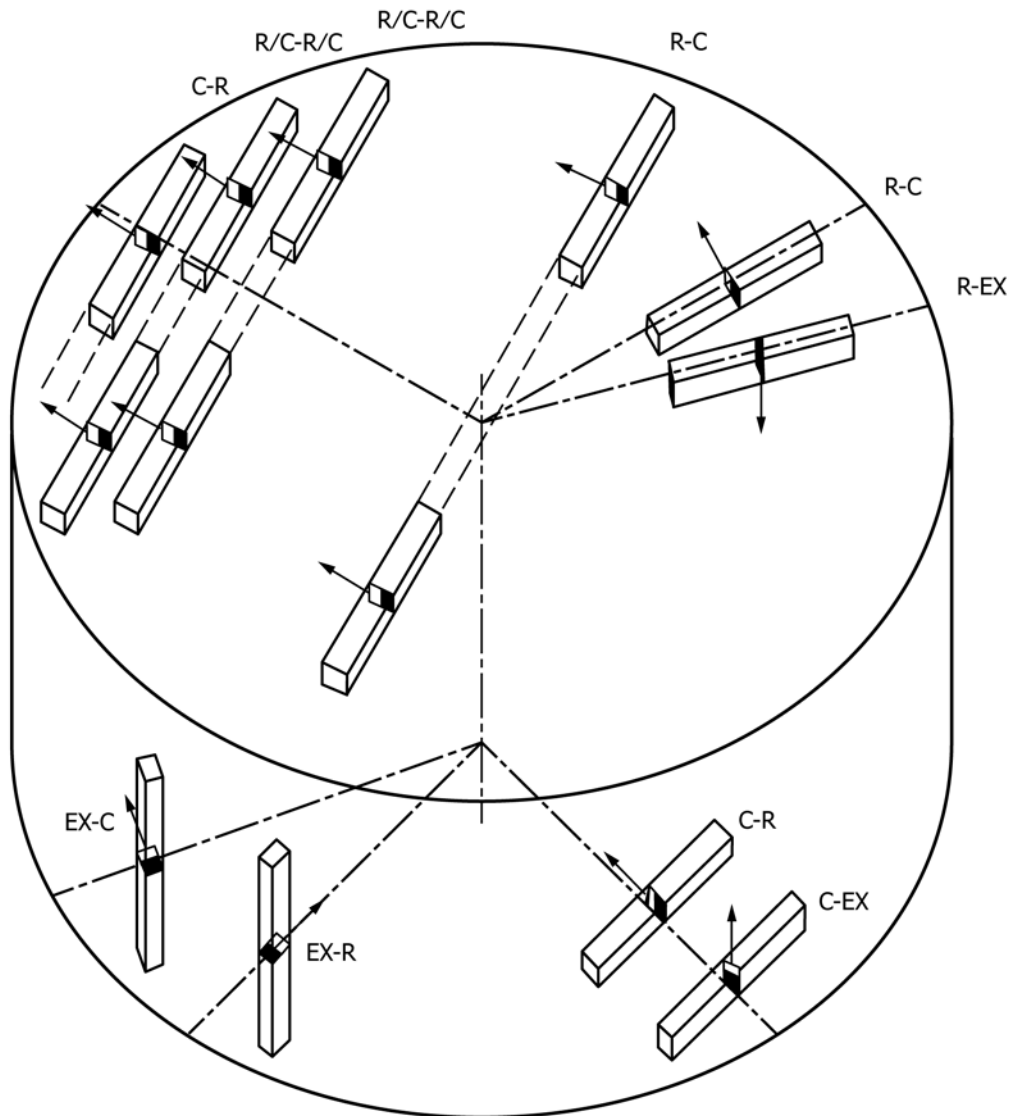

NOTE 1—Direction of crack propagation for each specimen orientation is indicated by an arrow.

FIG. A1.1 Crack-Plane Orientation

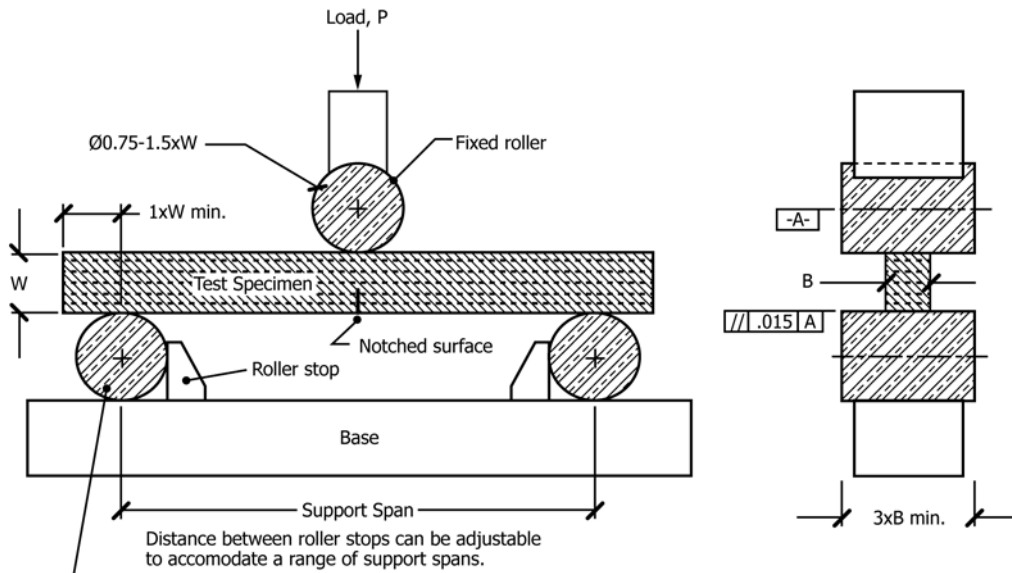

1. Support are rollers free to rotate outward to relieve frictional constraints.
2. Light springs or rubber bands can be used to initially hold rollers against stops.
3. Rollers hardened to 40 Rockwell C min.
4. Contact areas of support base should be sufficiently hard enough to prevent indentation by the rollers.

Notes:

1. The test fixture should be mechanically stiffer than the specimen if crosshead or actuator travel is used to measure specimen displacement under the applied load.
2. If parallelism and perpendicularity requirements (see Annex A3) for the test specimen cannot be met, the specimen could be tested using an articulating fixture that would allow the rollers to contact the specimen uniformly.
3. A recommended range of roller diameters is given. Contact stresses under the rollers are related to the roller diameter as well as the modulus of elasticity and Poisson's ratio of the roller material and that for the graphite test specimen. The user must be satisfied that the diameter of the support rollers and particularly the center roller does not contribute to the fracture of the specimen.

FIG. A1.2 Three-Point Test Fixture

Graphite Fracture Toughness Specimen -20 mm x 15 mm

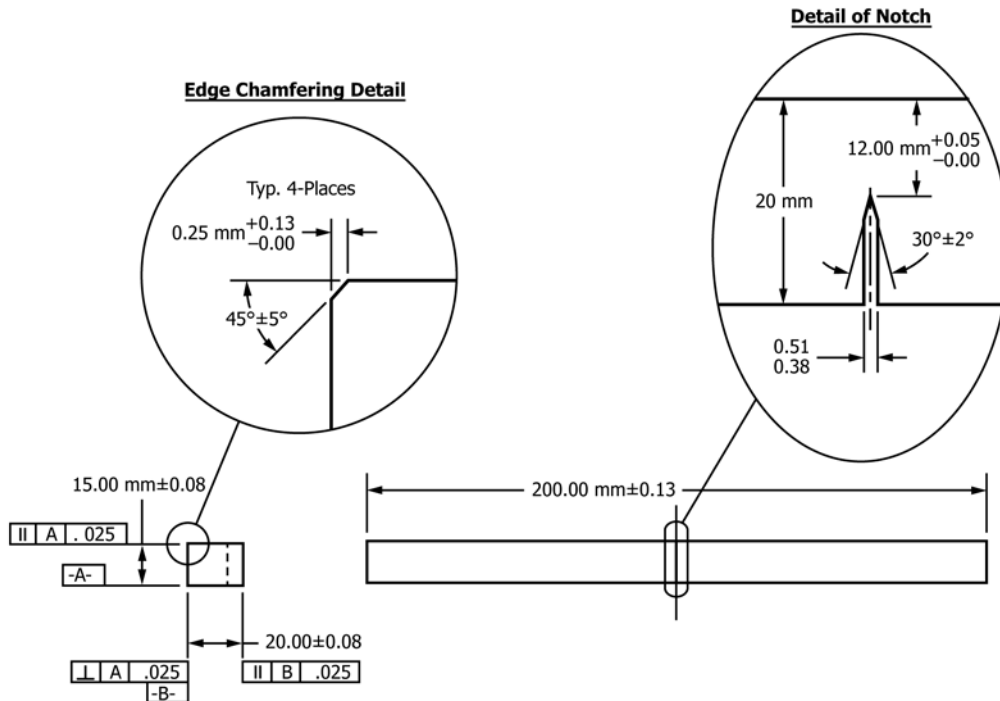

FIG. A1.3 Typical Test Specimen

ASTM International takes no position respecting the validity of any patent rights asserted in connection with any item mentioned in this standard. Users of this standard are expressly advised that determination of the validity of any such patent rights, and the risk of infringement of such rights, are entirely their own responsibility.

This standard is subject to revision at any time by the responsible technical committee and must be reviewed every five years and if not revised, either reapproved or withdrawn. Your comments are invited either for revision of this standard or for additional standards and should be addressed to ASTM International Headquarters. Your comments will receive careful consideration at a meeting of the responsible technical committee, which you may attend. If you feel that your comments have not received a fair hearing you should make your views known to the ASTM Committee on Standards, at the address shown below.

This standard is copyrighted by ASTM International, 100 Barr Harbor Drive, PO Box C700, West Conshohocken, PA 19428-2959, United States. Individual reprints (single or multiple copies) of this standard may be obtained by contacting ASTM at the above address or at 610-832-9585 (phone), 610-832-9555 (fax), or service@astm.org (e-mail); or through the ASTM website (www.astm.org). Permission rights to photocopy the standard may also be secured from the Copyright Clearance Center, 222 Rosewood Drive, Danvers, MA 01923, Tel: (978) 646-2600; http://www.copyright.com/