



Standard Test Method for Measurement of Effects of Automotive Engine Oils on Fuel Economy of Passenger Cars and Light-Duty Trucks in Sequence VID Spark Ignition Engine^{1,2}

This standard is issued under the fixed designation D7589; the number immediately following the designation indicates the year of original adoption or, in the case of revision, the year of last revision. A number in parentheses indicates the year of last reapproval. A superscript epsilon (ε) indicates an editorial change since the last revision or reapproval.

INTRODUCTION

Portions of this test method are written for use by laboratories that make use of ASTM Test Monitoring Center (TMC)³ services (see [Annex A1](#)).

The TMC provides reference oils, and engineering and statistical services to laboratories that desire to produce test results that are statistically similar to those produced by laboratories previously calibrated by the TMC.

In general, the Test Purchaser decides if a calibrated test stand is to be used. Organizations such as the American Chemistry Council require that a laboratory utilize the TMC services as part of their test registration process. In addition, the American Petroleum Institute and the Gear Lubricant Review Committee of the Lubricant Review Institute (SAE International) require that a laboratory use the TMC services in seeking qualification of oils against their specifications.

The advantage of using the TMC services to calibrate test stands is that the test laboratory (and hence the Test Purchaser) has an assurance that the test stand was operating at the proper level of test severity. It should also be borne in mind that results obtained in a non-calibrated test stand may not be the same as those obtained in a test stand participating in the ASTM TMC services process.

Laboratories that choose not to use the TMC services may simply disregard these portions.

1. Scope*

1.1 This test method covers an engine test procedure for the measurement of the effects of automotive engine oils on the fuel economy of passenger cars and light-duty trucks with gross vehicle weight 3856 kg or less. The tests are conducted using a specified spark-ignition engine with a displacement of 3.6 L (General Motors)⁴ on a dynamometer test stand. It applies to multi viscosity grade oils used in these applications.

¹ This test method is under the jurisdiction of ASTM Committee D02 on Petroleum Products, Liquid Fuels, and Lubricants and is the direct responsibility of Subcommittee D02.B0.10 on Standards Acceleration.

Current edition approved April 1, 2016. Published April 2016. Originally approved in 2009. Last previous edition approved in 2015 as D7589–15a. DOI:10.1520/D7589-16.

² The multi-cylinder engine test sequences were originally developed by an ASTM Committee D02 group. Subsequently, the procedures were published in an ASTM special technical publication. The Sequence VIB was published as Research Report RR:D02-1469, dated April 8, 1999.

³ The ASTM Test Monitoring Center will update changes in this test method by means of Information Letters. This edition includes all information letters through No. 15–1. Information letters may be obtained from the ASTM Test Monitoring Center, 6555 Penn Avenue, Pittsburgh, PA 15206-4489, Attention: Administrator.

⁴ Trademark of General Motors Corporation, 300 Renaissance Center, Detroit, MI 48265.

1.2 The values stated in SI units are to be regarded as standard. No other units of measurement are included in this standard.

1.2.1 *Exceptions*—Where there is no direct equivalent such as the units for screw threads, National Pipe threads/diameters, tubing size, and single source supply equipment specifications. Additionally, Brake Fuel Consumption (BSFC) is measured in kilograms per kilowatt-hour.

1.3 *This standard does not purport to address all of the safety concerns, if any, associated with its use. It is the responsibility of the user of this standard to establish appropriate safety and health practices and determine the applicability of regulatory limitations prior to use.*

1.4 This test method is arranged as follows:

Subject	Section
Introduction	
Scope	1
Referenced Documents	2
Terminology	3
Summary of Test Method	4
Significance and Use	5
Apparatus	6
General	6.1
Test Engine Configuration	6.2
Laboratory Ambient Conditions	6.3

*A Summary of Changes section appears at the end of this standard

Subject	Section	Subject	Section
Engine Speed and Torque Control	6.4	Non-Phased Camshaft Gears	9.4.20
Dynamometer	6.4.1	Internal Coolant Orifice	9.4.21
Dynamometer Torque	6.4.2	Calibration	10
Engine Cooling System	6.5	Stand/Engine Calibration	10.1
External Oil System	6.6	Procedure	10.1.1
Fuel System	6.7	Reporting of Reference Results	10.1.2
Fuel Flow Measurement	6.7.2	Instrument Calibration	10.2
Fuel Temperature and Pressure Control to the Fuel	6.7.3	Engine Torque Measurement System	10.2.3
Flowmeter		Fuel Flow Measurement System	10.2.4
Fuel Temperature and Pressure Control to Engine Fuel Rail	6.7.4	Coolant Flow Measurement System	10.2.5
Fuel Supply Pumps	6.7.5	Thermocouple and Temperature Measurement System	10.2.6
Fuel Filtering	6.7.6	Humidity Measurement System	10.2.7
Engine Intake Air Supply	6.8	Other Instrumentation	10.2.8
Intake Air Humidity	6.8.1	Test Procedure	11
Intake Air Filtration	6.8.2	External Oil System	11.1
Intake Air Pressure Relief	6.8.3	Flush Effectiveness Demonstration	11.2
Temperature Measurement	6.9	Preparation for Oil Charge	11.3
Thermocouple Location	6.9.5	Initial Engine Start-Up	11.4
AFR Determination	6.10	New Engine Break-In	11.5
Exhaust and Exhaust Back Pressure Systems	6.11	Oil Charge for Break-In	11.5.2
Exhaust Manifolds	6.11.1	Break-In Operating Conditions	11.5.3
Laboratory Exhaust System	6.11.2	Standard Requirements for Break-In	11.5.4
Exhaust Back Pressure	6.11.3	Routine Test Operation	11.6
Pressure Measurement and Pressure Sensor Locations	6.12	Start-Up and Shutdown Procedures	11.6.1
Engine Oil	6.12.2	Flying Flush Oil Exchange Procedures	11.6.2
Fuel to Fuel Flowmeter	6.12.3	Test Operating Stages	11.6.3
Fuel to Engine Fuel Rail	6.12.4	Stabilization to Stage Conditions	11.6.4
Exhaust Back Pressure	6.12.5	Stabilized BSFC Measurement Cycle	11.6.5
Intake Air	6.12.6	BLB1 Oil Flush Procedure for BL Oil Before Test Run 1	11.6.6
Intake Manifold Vacuum/Absolute Pressure	6.12.7	BSFC Measurement of BLB1 Oil Before Test Oil	11.6.7
Coolant Flow Differential Pressure	6.12.8	BLB2 Oil Flush Procedure for BL Oil Before Test Oil Run 2	11.6.8
Crankcase Pressure	6.12.9	BSFC Measurement of BLB2 Oil Before Test Oil	11.6.9
Engine Hardware and Related Apparatus	6.13	Percent Delta Calculation for BLB1 vs. BLB2	11.6.10
Test Engine Configuration	6.13.1	Test Oil Flush Procedure	11.6.11
ECU (Power Control Module)	6.13.2	Test Oil Aging, Phase I	11.6.12
Thermostat Block-Off Adapter Plate	6.13.3	BSFC Measurement of Aged (Phase I) Test Oil	11.6.13
Wiring Harness	6.13.4	Test Oil Aging, Phase II	11.6.14
Oil Pan	6.13.5	BSFC Measurement of Aged (Phase II) Test Oil	11.6.15
Engine Water Pump Adapter Plate	6.13.6	Oil Consumption and Sampling	11.6.16
Thermostat Block-Off Plate	6.13.7	Flush Procedure for BL Oil (BLA) After Test Oil	11.6.17
Oil Filter Adapter Plate	6.13.8	General Test Data Logging Forms	11.6.18
Modified Throttle Body Assembly	6.13.9	Diagnostic Review Procedures	11.6.19
Fuel Rail	6.13.10	Determination of Test Results	12
Miscellaneous Apparatus Related to Engine Operation	6.14	Report	13
Reagents and Materials	7	Precision and Bias	14
Engine Oil	7.1	Keywords	15
Test Fuel	7.2	Annexes	
Engine Coolant	7.3	ASTM Test Monitoring Center: Organization	Annex A1
Cleaning Materials	7.4	ASTM Test Monitoring Center: Calibration Procedures	Annex A2
Preparation of Apparatus	8	ASTM Test Monitoring Center: Maintenance Activities	Annex A3
Test Stand Preparation	8.2	ASTM Test Monitoring Center: Related Information	Annex A4
Engine Preparation	9	Detailed Specifications and Drawings of Apparatus	Annex A5
Cleaning of Engine Parts	9.3	Oil Heater Cerrobase Refill Procedure	Annex A6
Engine Assembly Procedure	9.4	Engine Part Number Listing	Annex A7
General Assembly Instructions	9.4.1	Safety Precautions	Annex A8
Bolt Torque Specifications	9.4.2	Report Format	Annex A9
Sealing Compounds	9.4.3	Statistical Equations for Mean and Standard Deviations	Annex A10
Harmonic Balancer	9.4.5	Oil Sump Full Level Determination Consumption	Annex A11
Thermostat	9.4.6	Measurement Calibration Procedure	
Coolant Inlet	9.4.7	Fuel Injector Evaluation	Annex A12
Oil Filter Adapter	9.4.8	Pre-test Maintenance Checklist	Annex A13
Dipstick Tube	9.4.9	Blow-by Ventilation System Requirements	Annex A14
Sensors, Switches, Valves, and Positioners	9.4.10	Calculation of Test Results	Annex A15
Ignition System	9.4.11	Calculation of Unweighted Baseline Shift	Annex A16
Fuel Injection System	9.4.12	Non-Phased Cam Gear and Position Actuator Installation	Annex A17
Intake Air System	9.4.13	Procedure	
Engine Management System	9.4.14		
Accessory Drive Units	9.4.15	Appendix	
Exhaust Manifolds	9.4.16	Procurement of Test Materials	Appendix X1
Engine Flywheel and Guards	9.4.17		
Lifting of Assembled Engines	9.4.18		
Engine Mounts	9.4.19		

2. Referenced Documents

2.1 ASTM Standards:⁵

- D86** Test Method for Distillation of Petroleum Products and Liquid Fuels at Atmospheric Pressure
- D235** Specification for Mineral Spirits (Petroleum Spirits) (Hydrocarbon Dry Cleaning Solvent)
- D240** Test Method for Heat of Combustion of Liquid Hydrocarbon Fuels by Bomb Calorimeter
- D323** Test Method for Vapor Pressure of Petroleum Products (Reid Method)
- D381** Test Method for Gum Content in Fuels by Jet Evaporation
- D445** Test Method for Kinematic Viscosity of Transparent and Opaque Liquids (and Calculation of Dynamic Viscosity)
- D525** Test Method for Oxidation Stability of Gasoline (Induction Period Method)
- D1319** Test Method for Hydrocarbon Types in Liquid Petroleum Products by Fluorescent Indicator Adsorption
- D2699** Test Method for Research Octane Number of Spark-Ignition Engine Fuel
- D3231** Test Method for Phosphorus in Gasoline
- D3237** Test Method for Lead in Gasoline by Atomic Absorption Spectroscopy
- D3338** Test Method for Estimation of Net Heat of Combustion of Aviation Fuels
- D4052** Test Method for Density, Relative Density, and API Gravity of Liquids by Digital Density Meter
- D4175** Terminology Relating to Petroleum Products, Liquid Fuels, and Lubricants
- D4485** Specification for Performance of Active API Service Category Engine Oils
- D5185** Test Method for Multielement Determination of Used and Unused Lubricating Oils and Base Oils by Inductively Coupled Plasma Atomic Emission Spectrometry (ICP-AES)
- D5453** Test Method for Determination of Total Sulfur in Light Hydrocarbons, Spark Ignition Engine Fuel, Diesel Engine Fuel, and Engine Oil by Ultraviolet Fluorescence
- D6750** Test Methods for Evaluation of Engine Oils in a High-Speed, Single-Cylinder Diesel Engine—1K Procedure (0.4 % Fuel Sulfur) and 1N Procedure (0.04 % Fuel Sulfur)
- D6837** Test Method for Measurement of Effects of Automotive Engine Oils on Fuel Economy of Passenger Cars and Light-Duty Trucks in Sequence VIB Spark Ignition Engine
- E29** Practice for Using Significant Digits in Test Data to Determine Conformance with Specifications
- E191** Specification for Apparatus For Microdetermination of Carbon and Hydrogen in Organic and Organo-Metallic Compounds
- IEEE/ASTM SI-10 Standard for Use of the International

⁵ For referenced ASTM standards, visit the ASTM website, www.astm.org, or contact ASTM Customer Service at service@astm.org. For *Annual Book of ASTM Standards* volume information, refer to the standard's Document Summary page on the ASTM website.

System of Units (SI): The Modern Metric System

2.2 SAE Standards:⁶

- J304** Engine Oil Tests
- J1423** Classification of Energy-Conserving Engine Oil for Passenger Cars and Light-Duty Trucks
- ### 2.3 API Publication:⁷
- API 1509** Engine Oil Licensing and Certification System
- ### 2.4 ANSI Standard:⁸
- ANSI MC96.1-1975** Temperature Measurement – Thermocouples

3. Terminology

3.1 Definitions:

3.1.1 *air-fuel ratio, n*—in internal combustion engines, the mass ratio of air-to-fuel in the mixture being induced into the combustion chambers. **D4175**

3.1.2 *automotive, adj*—descriptive of equipment associated with self-propelled machinery, usually vehicles driven by internal combustion engines. **D4485**

3.1.3 *blowby, n*—in internal combustion engines, that portion of the combustion products and unburned air/fuel mixture that leaks past piston rings into the engine crankcase during operation.

3.1.4 *break-in, v*—in internal combustion engines, the running of a new engine under prescribed conditions to help stabilize engine response and help remove initial friction characteristics associated with new engine parts. **D6837**

3.1.5 *calibrate, v*—to determine the indication or output of a (e.g., thermometer, manometer, engine) device or a given engine with respect to a standard.

3.1.6 *calibration oil, n*—an oil that is used to determine the indication or output of a measuring device or a given engine with respect to a standard. **D4175**

3.1.7 *engine oil, n*—a liquid that reduces friction or wear, or both, between the moving parts of an engine; removes heat, particularly from the underside of pistons; and serves as a combustion gas sealant for the piston rings.

3.1.7.1 *Discussion*—It may contain additives to enhance certain properties. Inhibition of engine rusting, deposit formation, valve train wear, oil oxidation, and foaming are examples. **D6750**

3.1.8 *fuel economy, n*—in internal combustion engines, the efficient use of gasoline. **D6837**

3.1.8.1 *Discussion*—Determined by comparing the rate of fuel consumption of a test oil with that displayed by baseline oil.

3.1.9 *lubricant, n*—any material interposed between two surfaces that reduces the friction or wear, or both, between them. **D4175**

⁶ Available from the Society of Automotive Engineers (SAE), 400 Commonwealth Dr. Warrendale, PA 15096-0001. This standard is not available separately. Order the SAE Handbook Vol 2, or the SAE Fuels and Lubricants Standards Manual HS-23.

⁷ Available from the American Petroleum Institute (API), 1220 L Street, NW, Washington, DC 20005.

⁸ Available from American National Standards Institute (ANSI), 25 W. 43rd St., 4th Floor, New York, NY 10036, <http://www.ansi.org>.

3.1.10 *non-reference oil, n*—any oil other than a reference oil, such as a research formulation, commercial oil, or candidate oil. **D4175**

3.1.11 *non-standard test, n*—a test that is not conducted in conformance with the requirements in the standard test method, such as running on an uncalibrated test stand, using different test equipment, applying different equipment assembly procedures, or using modified operating conditions. **D4175**

3.1.12 *purchaser, n*—of an ASTM test, a person or organization that pays for the conduct of an ASTM test method on a specified product. **D4175**

3.1.12.1 *Discussion*—The preferred term is purchaser. Deprecated terms that have been used are client, requester, sponsor, and customer.

3.1.13 *reference oil, n*—an oil of known performance characteristics used as a basis for comparison. **D4175**

3.1.14 *test oil, n*—any oil subjected to evaluation in an established procedure. **D4175**

3.1.15 *test start, n*—introduction of test oil into the engine. **D4175**

3.2 Definitions of Terms Specific to This Standard:

3.2.1 *aged test oil, n*—an engine oil to be tested that has been previously subjected to use in a spark-ignited operating engine for a prescribed length of service under prescribed conditions. **D6837**

3.2.2 *aging, n*—the subjecting of an engine oil to use in a spark-ignited operating engine for a prescribed length of service under prescribed conditions. **D6837**

3.2.3 *central parts distributor (CPD), n*—the manufacturer or supplier, or Both, of many of the parts and fixtures used in this test method. **D6837**

3.2.3.1 *Discussion*—Because of the need for availability, rigorous inspection, and control of many of the parts used in this test method, companies having the capabilities to provide the needed services have been selected as the official suppliers for the Sequence VID test method. These companies work closely with the Test Procedure Developer and with the ASTM groups associated with the test method to help ensure that the critical engine parts used in this test method are available to the testing industry and function satisfactorily.

3.2.4 *engine hours, n*—cumulative time that ignition is powered after engine installation.

3.2.4.1 *Discussion*—Engine hours will include any time accumulated on a different stand, including engine break-in.

3.2.5 *engine shutdown, n*—the engine is brought to a complete stop.

3.2.6 *flush, v*—to wash out with a rush of engine oil, during a prescribed mode of engine operation to minimize carryover effect from the previous oil and remove residues, before introducing new test oil. **D6837**

3.2.7 *flying flush, n*—in internal combustion engines, the washing out with a rush of engine oil, during a prescribed mode of engine operation to minimize carryover effect from the previously used oil and remove residues without stopping the engine after the previous test. **D6837**

3.2.8 *off test time, n*—time when the test is not operating at the scheduled test conditions, but shutting down the engine is not required.

3.2.9 *stage restart, n*—re-initiate a stage while the engine is running.

4. Summary of Test Method

4.1 The internal combustion engine with a displacement of 3.6 L is installed on a dynamometer test stand equipped with the appropriate controls for speed, torque, and various other operating parameters.

4.2 The test method consists of measuring the laboratory engine brake specific fuel consumption at 6 constant speed/torque/temperature conditions for the baseline calibration oil, test oil, and a repeat of the baseline calibration oil. The approximate test length is 155 h.

4.3 Aged test oil is compared directly to fresh VID BL (baseline oil) SAE 20W-30 (see X1.2) baseline calibration oil, that is run before and after the test oil. When changing from test oil to baseline oil, an intermediate flush with special flushing oil (FO) is required to minimize the possibility of a carryover effect from the previous oil.

4.4 Test results are expressed as a percent change in weighted fuel consumption relative to the baseline calibration oil.

5. Significance and Use

5.1 *Test Method*—The data obtained from the use of this test method provide a comparative index of the fuel-saving capabilities of automotive engine oils under repeatable laboratory conditions. A BL has been established for this test to provide a standard against which all other oils can be compared. The BL oil is an SAE 20W-30 grade fully formulated lubricant. The test procedure was not designed to give a precise estimate of the difference between two test oils without adequate replication. The test method was developed to compare the test oil to the BL oil. Companion test methods used to evaluate engine oil performance for specification requirements are discussed in the latest revision of Specification **D4485**.

5.2 *Use*—The Sequence VID test method is useful for engine oil fuel economy specification acceptance. It is used in specifications and classifications of engine lubricating oils, such as the following:

5.2.1 Specification **D4485**.

5.2.2 API 1509.

5.2.3 SAE Classification J304.

5.2.4 SAE Classification J1423.

6. Apparatus

6.1 *General*—Standardize certain aspects of each test stand in terms of stand hardware. Examples of components that are specified are certain pumps, valves, heat exchangers, heaters, and piping nominal inside diameter (ID). Where specified, four classes or categories of stand hardware have been designated:

6.1.1 Prints/photos for special parts are included in this procedure. Substitution of equivalent equipment is allowed, but

only after equivalency has been proven acceptable by the Sequence VI Surveillance Panel.

6.2 *Test Engine Configuration*—The test engine is a specially built General Motors (GM) 3.6 L (LY7) engine (see X1.3). Mount the engine on the test stand so that the flywheel friction face is $3.0^\circ \pm 0.5^\circ$ from the vertical with the front of the engine higher than the rear. The driveshaft angle shall be $1.5^\circ \pm 0.5^\circ$ from engine to dynamometer. The driveshaft angle shall be $0^\circ \pm 0.5^\circ$ in the horizontal plane.

6.3 *Laboratory Ambient Conditions*—Do not permit air from fans or ventilation systems to blow directly on the engine. Small (<35 L/s) fans may be used to direct air towards the knock sensor and oxygen sensors. The ambient laboratory atmosphere shall be relatively free of dirt, dust, or other contaminants as required by good laboratory standards and practices.

6.4 *Engine Speed and Torque Control*—The dynamometer speed and torque control systems shall be capable of maintaining the limits specified in Tables 2-4. The VID closed-loop control system maintains speed by electronic throttle and torque by dynamometer control. Since these speed and torque tolerances require sensitive and precise control, give particular attention to achieving and maintaining accurate calibration of the related instrument systems.

6.4.1 *Dynamometer*—Use a Midwest or Eaton 37 kW Model 758 dry gap dynamometer (see X1.4). Replacing an engine dynamometer during a test (reference or non-reference oil) is not acceptable. If a dynamometer needs to be replaced during a test, abort the test. Follow calibration requirements shown in 10.2.3 before starting each new test.

6.4.2 *Dynamometer Torque*:

6.4.2.1 *Dynamometer Load Cell*—Measure the dynamometer torque by a load cell of 0 kg to 45 kg. The dyno load cell is required to have the following features:

(1) Good temperature stability:
Zero ≤ 0.001 % FSO (Full Scale Output) per degree Celsius, and
Span ≤ 0.001 % FSO per degree Celsius.

(2) Nonlinearity ≤ 0.05 % FSO.

(3) Temperature compensation over range expected in laboratory 21 °C to 40 °C. A Lebow Model 3397 load cell (see X1.5) has been found suitable for this application.

6.4.2.2 *Dynamometer Load Cell Damper*—Do not use a load cell damper.

6.4.2.3 *Dynamometer Load Cell Temperature Control*—Control the load cell temperature. Enclose the dynamometer load cell to protect it from the variability of laboratory ambient temperatures. Maintain air in the enclosure within the operating temperature range specified by the load cell manufacturer within a variability of no more than 6 °C. Control temperature by a means that does not cause uneven temperatures on the body of the load cell.

6.4.2.4 *Dynamometer Connection to Engine*—Use a damper system or damped shaft with U-joints for the dynamometer-to-engine connection (see 6.2). The following have been found suitable and are currently used; Vulkan, Machine Service Inc. (see X1.31) with a stiffness of 5.2 kN·m/rad.

6.4.2.5 *Dynamometer Load Cell Power Supply*—Laboratory ambient temperatures can affect the accuracy of the load cell power supply. In order to minimize the error introduced by temperature changes to the load cell power supply, select a power supply with a temperature drift spec $< 15 \mu\text{V}/^\circ\text{C}$ (manufacturers of power supplies often report this drift specification in ppm, and 15 ppm is equivalent to $15 \mu\text{V}$).

6.5 *Engine Cooling System*—Use an external engine cooling system, as shown in Figs. A5.1-A5.5, to maintain the specified jacket coolant temperature and flow rate during the test. An

TABLE 1 Sequence VID Fuel Specification

	Test Method	
Octane, research min	D2699	96
Pb (organic), mg/L max	D3237	0.01 max
Sensitivity, min		7.5
Distillation range		
IBP, °C	D86	23.9 to 35
10 % point, °C	D86	48.9 to 57.2
50 % point, °C	D86	93.3 to 110
90 % point, °C	D86	148.9 to 162.8
E.P., °C (max)	D86	212.8
Sulfur, mass fraction %, max	D5453	3 min to 15 max
Phosphorous, mg/L, max	D3231	1.32
RVP, kPa	D323	60.0 to 63.4
Hydrocarbon composition		
Olefins, % max	D1319	10
Aromatics, %	D1319	26 min to 32.5 max
Saturates	D1319	Report
Existent gum, mg/100 mL, max	D381	5.0
Oxidation stability, min	D525	240 min
Carbon weight fraction	E191	Report
Hydrogen/Carbon ratio, mol basis	E191	Report
Net heating value, J/kg	D240	Report
Net heating value, J/kg	D3338	Report
API gravity	D4052	58.7 min to 61.2 max

TABLE 2 Sequence VID New Engine Cyclic Break-in^A

	Cycle	
	A	B
Time at Each Step, min	4	1
Time to Decel. to Step A, s		15 max
Time to Accel. to Step B, s	15 max	
Speed, r/min	1500 ± 50	3500 ± 50
Power, kW	6.0	16.5
Torque, N·m	38.00 ± 5	45.00 ± 5
Oil Gallery, °C	80 ± 2	80 ± 2
Coolant In, °C	80 ± 2	80 ± 5
Coolant Flow, L/min	80 ± 5	80 ± 5
Intake Air Temperature and Humidity	Control Not Required	
Exh. Back Press., kPa	105	Not Specified
AFR	Record	Not Specified
Fuel Pressure to Fuel Rail, kPa	405 ± 10	405 ± 10
Fuel Temperature to Fuel Rail, °C	22 ± 2	22 ± 2
Fuel Flow, kg/h	Not Specified	Not Specified
BSFC, kg/kWh	Not Specified	Not Specified

^A The time at each cycle and their acceleration and deceleration times shall be adhered to; target all parameters as close as possible.

TABLE 3 Sequence VID Test Operating Conditions^A

Parameter	Stage 1	Stage 2	Stage 3	Stage 4	Stage 5	Stage 6
Speed, r/min ^B	2000 ± 5	2000 ± 5	1500 ± 5	695 ± 5	695 ± 5	695 ± 5
Load Cell, N·m ^B	105.0 ± 0.1	105.0 ± 0.1	105.0 ± 0.1	20.0 ± 0.1	20.0 ± 0.1	40.0 ± 0.1
Nominal, Power kW	22.0	22.0	16.5	1.5	1.5	2.9
Oil Gallery, °C ^B	115 ± 2	65 ± 2	115 ± 2	115 ± 2	35 ± 2	115 ± 2
Coolant-In, °C ^B	109 ± 2	65 ± 2	109 ± 2	109 ± 2	35 ± 2	109 ± 2
Stabilization Time, min ^C	60	60	60	60	60	60
	All Stages					
Temperatures, °C						
Oil Circulation	Record					
Coolant Out	Record					
Intake Air ^B	29 ± 2					
Fuel-to-Flowmeter ^D	20 to 32 (delta from the max stage average reading shall be ≤4)					
Fuel-to-Fuel Rail ^B	22 ± 2					
Delta Load Cell ^D	Delta from the max stage average reading shall be ≤12					
Oil Heater	205 max					
Pressures						
Intake Air, kPa	0.05 ± 0.02					
Fuel-to-Flowmeter, kPa	110 ± 10					
Fuel-to-Fuel Rail, kPa	405 ± 10					
Intake Manifold, kPa abs.	Record					
Exhaust Back Pressure, kPa abs. ^B	Stages 1-3 = 105.00 ± 0.17 / Stages 4-6 = 104.00 ± 0.17					
Engine Oil, kPa	Record					
Crankcase, kPa	0.0 ± 0.25					
Flows						
Engine Coolant, L/min	80 ± 4					
Fuel Flow, kg/h ^B	Record					
Humidity, Intake Air, g/kg of dry air	11.4 ± 0.8					
Air-to-Fuel Ratio ^B	14.00:1 to 15.00:1					
Air-to-Fuel Ratio ^D	Delta from max stage average reading shall be ≤0.50					

^A Controlled parameters should be targeted for the middle of the specification range.

^B Critical measurement and control parameters.

^C Counted from the time the temperature set points are initially adjusted to the specific levels.

^D Difference between the maximum stage average reading of the entire test and the individual stage average readings.

alternative cooling system is shown in Fig. A5.3. The systems shall have the following features:

6.5.1 Pressurize the coolant system at the top of the reservoir. Control the system pressure to 70 kPa ± 10 kPa. Install a pressure cap or relief valve (PC-1 in Figs. A5.1-A5.3) (see X1.6) capable of maintaining system pressure within the above requirements.

6.5.2 The pumping system shall be capable of producing 80 L/min ± 4 L/min. A Gould's G&L centrifugal pump (P-1 in Figs. A5.1-A5.3), Model NPE, Size 1ST, mechanical seal, with a 1.4914 kW, 3450 r/min motor, has been found suitable for this application (see X1.7). Voltage and phase of the motor is optional. VFD [variable frequency drive] devices are acceptable in this application.

TABLE 4 Sequence VID Test Operating Conditions^A Stage Flush and Stage Aging Hours SI Units

	Stage Flush	Aging Phase I & Phase II
Speed, r/min	1500 ± 5	2250 ± 5
Torque, N-m	70.00 ± 0.10	110.00 ± 0.10
	Temperatures, °C ^B	
Oil Gallery	115 ± 2	120 ± 2
Coolant In	109 ± 2	110 ± 2
Oil Circulation	Record	Record
Coolant Out	Record	Record
Intake Air	29 ± 2	29 ± 2
Fuel-to-Flowmeter ^C	20 to 32	20 to 32
Fuel-to-Rail	22 ± 2	22 ± 2
	Pressures	
Intake Air, kPa	0.05 ± .02	0.05 ± 0.02
Fuel-to-Flowmeter, kPa	110 ± 10	110 ± 10
Fuel-to-Rail, kPa	405 ± 10	405 ± 10
Intake Manifold, kPa abs	Record	Record
Exhaust Back, kPa abs	105.00 ± 0.20	105.00 ± 0.20
Engine Oil, kPa	Record	Record
	Flows and Others	
Engine Coolant, L/min	80 ± 4	80 ± 4
Fuel Flow, kg/h	Record	Record
Humidity, Intake Air	Record	Record
g/kg, of dry air	11.4 ± 0.8	11.4 ± 0.8
Air-to-Fuel Ratio	14.00:1 to 15.00:1	14.00:1 to 15.00:1
Crankcase, Pressure, kPa	N/A	0.0 ± 0.25

^A Controlled parameters should be targeted for the middle of the specification range.

^B Counted from the time the temperature set points are initially adjusted to the specific levels.

^C ±3 °C within this range.

6.5.3 The coolant system volume is not specified; however certain cooling system components are specified as shown in **Figs. A5.1-A5.3**. Adhere to the nominal ID of the line sizes as shown in **Figs. A5.1-A5.3**.

6.5.4 The specified heat exchanger (HX-1 in **Fig. A5.1**) is an ITT Standard brazed plate model 320-20, Part No. 5-686-06-020-001 or ITT Bell & Gossett brazed plate model BP-75H-20, Part No. 5-686-06-020-001 (see **X1.8**). Parallel or counter flow through the heat exchanger is permitted.

6.5.4.1 Approved replacement heat exchangers are: ITT Bell & Gossett brazed plate Model BP-420-20, Part No. 5-686-06-020-005 and ITT Bell & Gossett brazed plate Model BP-422-20, Part No. 5-686-06-020-007 (see **X1.8**).

6.5.4.2 The specified heat exchanger(s) for the alternative cooling system (see **Figs. A5.2 and A5.3**) are an ITT shell and tube Model BCF 5-030-06-048-001 or an American Industrial AA-1248-3-6-SP (see **X1.8**).

6.5.5 An orifice plate (OP-1 in **Fig. A5.1**) is specified. It is recommended that the orifice plate be sized to provide a pressure drop equal to that of heat exchanger HX-1 and install it in the bypass loop of the coolant system.

6.5.5.1 An orifice plate (OP-1) is not required when using the alternative cooling system (see **Figs. A5.2 and A5.3**).

6.5.6 An orifice plate (differential pressure) (FE-103 in **Figs. A5.1-A5.3**) is specified (see **X1.9**). Use an orifice flange, 1½ NPT. Size the orifice plate to yield a pressure drop of 11.21 kPa ± 0.50 kPa at a flow rate of 80 L/min. There shall be 10 diameters upstream and 5 diameters downstream of straight, smooth pipe with no reducers or increasers. Flange size shall be the same size as pipe size. Threaded, slip-on or

weld neck styles can be used as long as a consistent pipe diameter is kept throughout the required lengths. An orifice obtained from Flowell (see **X1.9**) has been found suitable.

6.5.7 A control valve (TCV-104 in **Figs. A5.1 and A5.2**) is required for controlling coolant temperature by directing flow through the heat exchanger, HX-1, or diverting it through the bypass portion of the cooling system.

6.5.7.1 A Badger Meter Inc. Model No. 9003TCW36SV3AxxL36 (air-to-close), or Model No. 9003TCW36SV1AxxL36 (air-to-open) 3-way globe (divert), 2 in. valve is the specified valve (see **X1.10**).

6.5.7.2 A Badger Meter Inc. Model No. 9003TCW36SV3A29L36 (air-to-close), or Model No. 9003TCW36SV1A29L36 (air-to-open) are also acceptable if the trim package used with these valves has a CV of 16.0.

6.5.7.3 Install the valve in a manner so that loss of air pressure to the controller results in coolant flow through the heat exchanger rather than through the coolant bypass (fail safe). Air-to-open/air-to-close is optional.

6.5.7.4 Control valve (TCV-104) is not required when using the alternative cooling system (see **Figs. A5.2 and A5.3**).

6.5.8 A control valve (FCV-103 in **Figs. A5.1-A5.3**) is required for controlling the coolant flow rate to 80.0 L/min ± 4 L/min. A Badger Meter Inc. Model No. 9003GCW36SV3A29L36, 2-way globe, 2 in., air-to-close valve is the specified valve (see **X1.10**). A VFD device (P-1 in **Fig. A5.3**) would require this value.

6.5.9 Use a Viatran model 274/374, Validyne model DP15 or P55, or Rosemount models 1151 or 3051 differential

TABLE 5 VID Test Schedule

		Estimated Elapsed Time, h ^A
BLB-1 Oil Test		
1.	Double flush to BLB-1	1:30
2.	S60, BSFC/fuel flow × 6 at Stage 1 ^B	1:30
3.	S60, BSFC/fuel flow × 6 at Stage 2	1:30
4.	S60, BSFC/fuel flow × 6 at Stage 3	1:30
5.	S60, BSFC/fuel flow × 6 at Stage 4	1:30
6.	S60, BSFC/fuel flow × 6 at Stage 5	1:30
7.	S60, BSFC/fuel flow × 6 at Stage 6	1:30
	Warm-up to Stage Flush	0:30
	Sub Total	11:00
BLB-2 Oil Test		
1.	Double flush to BLB-2	1:30
2.	S60, BSFC/fuel flow × 6 at Stage 1 ^B	1:30
3.	S60, BSFC/fuel flow × 6 at Stage 2	1:30
4.	S60, BSFC/fuel flow × 6 at Stage 3	1:30
5.	S60, BSFC/fuel flow × 6 at Stage 4	1:30
6.	S60, BSFC/fuel flow × 6 at Stage 5	1:30
7.	S60, BSFC/fuel flow × 6 at Stage 6	1:30
	Warm-up to Stage Flush	0:30
	Sub Total	11:00
BLB-3 Oil Test (if required)		
1.	Double flush to BLB-2	1:30
2.	S60, BSFC/fuel flow × 6 at Stage 1 ^B	1:30
3.	S60, BSFC/fuel flow × 6 at Stage 2	1:30
4.	S60, BSFC/fuel flow × 6 at Stage 3	1:30
5.	S60, BSFC/fuel flow × 6 at Stage 4	1:30
6.	S60, BSFC/fuel flow × 6 at Stage 5	1:30
7.	S60, BSFC/fuel flow × 6 at Stage 6	1:30
	Warm-up to Stage Flush	0:30
	Sub Total	11:00
Phase I Aging		
1.	Double flush to Non-reference Oil	1:30
2.	Age 16 Hours	16:00
3.	S60, BSFC/fuel flow × 6 at Stage 1 ^B	1:30
4.	S60, BSFC/fuel flow × 6 at Stage 2	1:30
5.	S60, BSFC/fuel flow × 6 at Stage 3	1:30
6.	S60, BSFC/fuel flow × 6 at Stage 4	1:30
7.	S60, BSFC/fuel flow × 6 at Stage 5	1:30
8.	S60, BSFC/fuel flow × 6 at Stage 6	1:30
	Sub Total	26:30
Phase II Aging		
2.	Age 84 Hours	84:00
3.	S60, BSFC/fuel flow × 6 at Stage 1 ^B	1:30
4.	S60, BSFC/fuel flow × 6 at Stage 2	1:30
5.	S60, BSFC/fuel flow × 6 at Stage 3	1:30
6.	S60, BSFC/fuel flow × 6 at Stage 4	1:30
7.	S60, BSFC/fuel flow × 6 at Stage 5	1:30
8.	S60, BSFC/fuel flow × 6 at Stage 6	1:30
	Warm-up to Stage Flush	0:30
	Sub Total	93:30
FO to BL Flush		
	Flush in FO & Run	0:30
	Flush in FO & Run	2:00
1.	Double flush to BL After	1:30
2.	S60, BSFC/fuel flow × 6 at Stage 1 ^B	1:30
3.	S60, BSFC/fuel flow × 6 at Stage 2	1:30
4.	S60, BSFC/fuel flow × 6 at Stage 3	1:30
5.	S60, BSFC/fuel flow × 6 at Stage 4	1:30
6.	S60, BSFC/fuel flow × 6 at Stage 5	1:30
7.	S60, BSFC/fuel flow × 6 at Stage 6	1:30
	Sub Total	13:00

^A Adhere to stabilization times and times for the 6 replicate BSFC measurements. Warm-up and cool-down times included in flushing elapsed times are estimates.

^B Example: Stabilize 60 min followed by 6 replicate BSFC measurements at intervals of 5 min, consisting of (set-up for 3 min, and time averaged BSFC with Stage 1 operating conditions 2 min).

pressure transducer for reading the coolant flow rate at the orifice plate (FE-103 in [Figs. A5.1-A5.3](#)) (see [X1.11](#)).

6.5.10 Replace the engine water pump with a water pump plate OHT6D-005-1, shown in [Fig. A5.4](#).

6.5.11 A coolant reservoir, a coolant overflow container, and a sight glass are required as shown in **Figs. A5.1-A5.3** and **Fig. A5.5**. The design or model of these items is optional.

6.5.12 Use a control valve (TCV-101 in **Figs. A5.2 and A5.3**) for controlling the process water flow rate through the heat exchanger HX-1. A Badger Meter Inc. Model 9001GCW36SV3Axxx36 (air-to-close) or Model 9001GCW36SV1Axxx36 (air-to-open), 2-way globe, 1-in. valve have been found to be suitable for this application (see **X1.10**).

6.5.13 Use a 1½-in. NPT sight glass in the main coolant circuit (SG-1 in **Figs. A5.1-A5.3**). The make/model is optional.

6.5.14 Brass, copper, galvanized or stainless steel materials are recommended for hard plumbing in the coolant system.

6.5.15 The materials used for process water, hot water, chilled water, process air, engine coolant overflow, and engine coolant transducer tubing are at the discretion of the laboratory.

6.5.16 The system shall have provisions (for example, low point drains) for draining all of the flushing water prior to installing a new coolant mixture.

6.6 *External Oil System*—An external oil system as shown in **Figs. A5.6-A5.10** is required. Although all of the systems are interconnected in some manner, the overall external oil system is comprised of two separate circuits: (1) the flying flush system, which allows the oil to be changed while the engine is running, and (2) the circulation system for oil temperature control. Consider the engine oil pan (OHT6D-001-1) shown in **Fig. A5.9** a part of the external oil system. Minimize the external oil volume of all of the circuits as well as the length of connections and surfaces that are in contact with more than one oil in the flush system to enable more thorough flying flushes (see **X1.23**).

6.6.1 The flush system has a high capacity scavenge pump, that pumps used oil into a minimum 6.0 L capacity dump reservoir while fresh oil is drawn into the engine. The dump reservoir float switch then resets certain solenoids and the engine refills to the level established by the float switch in the engine oil pan (which then closes the solenoid to the fresh oil reservoir).

6.6.2 The oil heat/cool loop uses a proportional controller to bypass the cooling heat exchanger. Control the temperature within narrow limits with minimal additional heat (and surface temperatures). The system can respond quickly to establish the different oil gallery temperatures required in the procedure. Arrange the proportional three-way control valve to go to its mid-point during the flying flushes to avoid trapping oil, and there shall be some cooling during test oil aging so that no oil is trapped in the cooler.

6.6.3 Do not use cuprous materials in any of the oil system (excluding the oil scavenge discharge system) except as may be required by the use of mandatory equipment in this procedure.

6.6.4 The flying flush system (see **Fig. A5.6**) shall have the following features:

6.6.4.1 A scavenge pump, Viking Series 475, gear type, close-coupled pump, model H475M is specified (see **X1.13**).

The pump shall have an electric motor drive of 1140 r/min to 1150 r/min with a minimum of 0.56 kW. Voltage and phase are optional.

6.6.4.2 A reservoir with a minimum capacity of 19 L. It is recommended that the system include three reservoirs, one for BL calibration oil, one for FO (flush oil), and one for test oil.

6.6.4.3 An oil stirrer in each oil reservoir.

6.6.4.4 An oil heating system (with appropriate controls) for each oil reservoir with the capability of heating the oil in the reservoir to 93 °C to 107 °C.

6.6.4.5 A dump reservoir (see **Fig. A5.8**) with a minimum capacity of 6.0 L.

6.6.4.6 A dump reservoir float switch is required. (FLS-136 in **Fig. A5.8**) The make and model is optional. An OHT-6D001-04/ Switch, Level, Gems, high temperature float switch has been found suitable for this application (see **X1.23**).

6.6.5 The circulation system for oil temperature control shall have the following features:

6.6.5.1 A total volume, including oil volume in the oil pan to the full mark, shall be 5.4 L.

6.6.5.2 Use a positive displacement oil circulation pump. A Viking Series 4125, Model G4125, no relief valve, base-mounted is specified (see **X1.15**). The pump shall have a V-belt or direct drive electric motor of 1140 r/min to 1150 r/min with a minimum power of 0.56 kW. Voltage and phase are optional.

NOTE 1—If using a V-belt drive, use a 1:1 pulley ratio so that the final speed of the pump is a nominal 1150 r/min.

6.6.5.3 Use solenoid valves (FCV-150A, FCV-150C, FCV-150D, and FCV-150E, in **Fig. A5.6**) (see **X1.16**).

(1) FCV-150F and its related lines/piping are optional.

(2) FCV-150A is a Burkert Type 251 piston-operated valve used with a Type 312 solenoid valve (or a Burkert Type 2000 piston-operated valve used with a Type 311, 312, or 330 solenoid valve) for actuation of air supply to the piston valve, solenoid valve direct-coupled to piston valve, normally closed, explosion proof (left to the discretion of the laboratory), and watertight, ¾ in., 2-way, stainless steel NPT fitting.

(3) FCV-150C is a Burkert Type 251 piston-operated valve used with a Type 312 solenoid valve (or a Burkert Type 2000 piston-operated valve used with a Type 311, 312 or 330 solenoid valve) for actuation of air supply to the piston valve, solenoid valve direct-coupled to the piston valve, normally open, explosion proof (left to the discretion of the laboratory) and watertight, ½ in., 2-way, stainless steel NPT fitting.

(4) FCV-150D and FCV-150E are Burkert Type 251 piston-operated valves used with a Type 312 solenoid valve (or a Burkert Type 2000 piston-operated valve used with a Type 311, 312 or 330 solenoid valve) for actuation of air supply to the piston valve, solenoid valve direct-coupled to the piston valve, normally closed, explosion proof (left to the discretion of the laboratory), and watertight, ½ in., 2-way, stainless steel NPT fitting.

6.6.5.4 Use control valve (TCV-144 in **Fig. A5.6**). The specified valve is a Badger Meter Inc. Model No.

1002TBN36SVOSALN36, 3-way globe (divert), ½ in., air to open valve (see [X1.17](#)).

6.6.5.5 Use a heat exchanger (HX-6 in [Fig. A5.6](#)) for oil cooling. The specified heat exchanger is an ITT model 310-20 or an ITT Bell & Gossett, model BP-25-20 (Part No. 5-686-04-020-001), or an ITT Bell & Gossett, model BP-410-20 (Part No. 5-694-10-020-002), brazed plate (see [X1.18](#)).

NOTE 2—The ITT Standard and ITT Bell & Gossett heat exchangers have been standardized under one model with two part numbers. The new replacement is Model BP410-20, Part No. 5-686-04-020-002 (no mounting tabs) or Part No. 5-694-10-020-002 (includes mounting tabs).

6.6.5.6 Use an electric heater (EH-5 in [Fig. A5.6](#)) for oil heating. The specified heater is a heating element inserted in the liquid Cerrobased inside a Labeco oil heater housing (see [X1.19](#)). Any heater elements rated at 3000 W may be used within the Labeco housing. There are two recommended heating elements: (1) a three element with Incaloy sheath, Chromolox Part No. GIC-MTT-330XX, 230 V, single phase, and (2) Wiegand Industries/Chromolox, Emerson Electric Model MTS-230A, Part No. 156-019136-014, 240 V single phase.

(1) It is specified that a thermocouple be installed in the external oil heater so that the temperature can be monitored. Install this thermocouple into the top of the heater into the Cerrobased (see [Fig. A5.7](#)) to an insertion depth of 245 mm ± 3 mm. Do not exceed the maximum temperature of 205 °C.

(2) The procedure for replacing a heating element is detailed in [Annex A6](#).

6.6.5.7 Install two oil filters (FIL-1 and FIL-2 in [Fig. A5.6](#)) in the external oil system. The filters specified are OHT6A-012-3 with a stainless steel screen having a rating of 28 µm, Part No. OHT6A-013-2 (see [X1.20](#)). Locate one filter anywhere in the external oil system after the oil circulation pump, and locate the other between the engine oil pump and where the oil enters the engine oil gallery.

6.6.5.8 Use modified oil filter adapter assembly, Part No. OHT6D-003-1 (see [X1.21](#)), as shown in [Fig. A5.6](#).

6.6.5.9 Engine oil plumbing shall be stainless steel tubing or piping or flexible hose suitable for use with oils at the temperatures specified (see [Fig. A5.6](#)). When using a flexible hose in the external oil system, excluding the line to the dump tank, use either Aeroquip No. 8 (Part No. 2807-8) or Aeroquip No. 10 (Part No. 2807-10) (see [X1.22](#)).

6.6.5.10 Insulation of plumbing for the external oil circulation system is mandatory. Insulation material selection is optional.

6.6.5.11 *Engine Oil Pan*—Use oil pan OHT6D-001-1. Use oil displacement blocks OHT-6D-001-0201 or OHT-6E-001-0201. A sight glass is provided for monitoring the oil level and determining oil consumption. See [A11.2](#) for instructions on oil consumption measurement/calibration.

6.7 *Fuel System*—A typical fuel delivery system incorporating all of the required features is shown in [Fig. A5.11](#). The fuel system shall include provisions for measuring and controlling fuel temperature and pressure into the fuel flow measuring equipment and into the engine fuel rail.

6.7.1 There shall be a minimum of 100 mm of flexible line at the inlet and outlet of the fuel flowmeter (rubber/synthetic suitable for use with gasoline). Compression fittings are allowed for connecting the flexible lines to the fuel flowmeter. Fuel supply lines from the fuel flow measurement equipment to the engine fuel rail shall be stainless steel tubing or piping or any flexible hose suitable for use with gasoline.

6.7.2 *Fuel Flow Measurement*—Measure the critical fuel flow rate throughout the test. Use a Micro Motion Model CMF010 mass flow meter with either a RFT9739, 2500 MVD, 2700MVD or 1700MVD transmitter, see [X1.24](#). The Micro Motion sensor may be mounted in a vertical or a horizontal position.

6.7.3 *Fuel Temperature and Pressure Control to the Fuel Flow Meter*—Maintain fuel temperature and pressure to the fuel flowmeter at the values specified in [Tables 2-4](#). Precise fuel pressure control without fluctuation or aeration is mandatory for test precision. The fuel pressure regulator shall have a safety pressure relief, or a pressure relief valve, parallel to pressure regulator for safety purposes.

6.7.4 *Fuel Temperature and Pressure Control to Engine Fuel Rail*—Maintain fuel temperature and pressure to the engine fuel rail at the values specified in [Tables 2-4](#). Precise fuel temperature and precise fuel pressure control without fluctuation or aeration is mandatory for test precision.

6.7.5 *Fuel Supply Pumps*—The method of providing fuel to the fuel flowmeter and engine is at the laboratory's discretion as long as the requirements for fuel pressure and temperature are met. The average fuel pressure for this engine is 405 kPa.

6.7.6 *Fuel Filtering*—Filter the fuel supplied to the test stand in order to minimize fuel injector difficulties.

6.8 *Engine Intake Air Supply*—Use suitable apparatus to deliver air to the engine intake air filter at approximately 4.0 m³/min. The intake air supply system shall be capable of controlling moisture content, dry bulb temperature, and inlet air pressure as specified in [Tables 3 and 4](#), which is 11.4 g/kg ± 0.8 g/kg of dry air, 29 °C ± 2 °C, and 0.05 kPa ± 0.02 kPa. The specified engine intake air system components are considered part of the laboratory intake air system.

6.8.1 *Intake Air Humidity*—Measure humidity with the laboratory's primary humidity system. Correct each reading for non-standard barometric conditions, using the following equation:

$$\text{Humidity (corrected), g/kg} = 621.98 \times (P_{\text{sat}} / (P_{\text{bar}} - P_{\text{sat}})) \quad (1)$$

where:

P_{sat} = saturation pressure, mm Hg, and

P_{bar} = barometric pressure, mm Hg.

6.8.2 *Intake Air Filtration*—The air supply system shall provide either water-washed or filtered air to the duct. Any filtration apparatus utilized shall have sufficient flow capacity to permit control of the air pressure at the engine.

6.8.3 *Intake Air Pressure Relief*—The intake air system shall have a pressure relief device located upstream of the engine intake air filter snorkel. The design of the relief device is not specified.

6.9 *Temperature Measurement*—The test requires the accurate measurement of oil, coolant, and fuel temperatures, and care must be taken to ensure temperature measurement accuracy.

6.9.1 Check all temperature devices for accuracy at the temperature levels at which they are to be used. This is particularly true of the thermocouples used in the oil gallery, the coolant in, the inlet air, and the fuel-to-fuel rail. Type J (Iron-Constantan) thermocouples are recommended for temperature measurement, but Type J, Type K (Chromel-Alumel), or Type E (Chromel/Constantan) thermocouples may be used.

6.9.2 All thermocouples (excluding the oil heater thermocouple) shall be premium grade, sheathed types with premium wire. Use thermocouples with a diameter of 3.2 mm. Thermocouple lengths are not specified, but in all cases shall be long enough to allow thermocouple tip insertion to be in mid-stream of the medium being measured. The thermocouples shall not have thermocouple sheath greater than 50 mm when exposed to laboratory ambient temperature.

6.9.3 Some sources of thermocouples that have been found suitable for this application are: Leeds and Northrup, Conax, Omega, Revere, and Thermo Sensor (see [X1.14](#)). Match thermocouples, wires, and extension wires to perform in accordance with the special limits of error as defined by ANSI in publication MC96.1-1975.

6.9.4 System quality shall be adequate to permit calibration to ± 0.56 °C for individual thermocouples.

6.9.5 *Thermocouple Location*—Locate all thermocouple tips in the center of the stream of the medium being measured unless otherwise specified.

6.9.5.1 *Oil Inlet (Gallery)*—Insert the thermocouple into the modified oil filter adapter plate so that the thermocouple tip is flush with the face of the adapter and located in the center of the stream of flow.

6.9.5.2 *Oil Circulation*—Locate the oil circulation thermocouple in the tee in the front of the oil pan where the oil from the external heat/cool circuit returns oil to the pan. The tip of the thermocouple shall be at the junction of the side opening in the tee with respect to the through passage in the tee.

6.9.5.3 *Engine Coolant In*—Locate the thermocouple tip in the center of the stream of flow and within the outside of the OHT6D-005-1 water pump adapter inlet by 150 mm.

6.9.5.4 *Engine Coolant Out*—Locate the thermocouple tip in the center of the stream of flow and in the coolant return neck within 8 cm of the housing outlet.

6.9.5.5 *Intake Air*—Locate the thermocouple in the GM plastic elbow in front of the throttle body as shown in [Fig. A5.12](#).

6.9.5.6 *Fuel to Fuel Flowmeter*—Locate the thermocouple upstream of the fuel flow meter inlet within a line length of 100 mm to 500 mm.

6.9.5.7 *Fuel to Engine Fuel Rail*—Insert the thermocouple into the center of a tee or cross fitting and locate it within 550 mm from the center point of the fuel rail inlet.

6.9.5.8 *Load Cell*—Locate the thermocouple within the load cell enclosure.

6.10 *AFR Determination*—Determine engine air-fuel ratio (AFR) by an AFR analyzer. Analysis equipment shall be capable of near continuous operation for 30 min periods.

6.10.1 The AFR analyzer shall meet the following specifications:

Accuracy	± 0.1 AFR when 14.7 AFR with H/C = 1.85, O/C = 0.000
----------	----------------------------------------------------------------

6.10.1.1 Temperature of exhaust gas used by sensor: -7 °C to 900 °C. Horiba model MEXA 700 and ECM AFM1000 analyzers have been found suitable for this application (see [X1.25](#)).

6.10.2 The specified location of the analyzer sensing element in the exhaust system is shown in [Fig. A5.13](#).

6.11 *Exhaust and Exhaust Back Pressure Systems:*

6.11.1 *Exhaust Manifolds*—Use production cast iron exhaust manifolds, GM Part # 12571102 Left and 12571101 Right, heat shields, GM part numbers 12617267 and 12580706, and OHT left #OHT6D-010-1 and right #OHT6D-009-1 take down tube assemblies (see [X1.34](#)). Take down tubes may need to be shortened to facilitate installation at the laboratory. O2 sensors, OHT Part # OHT6D-047-1, will mount in the second hole downstream on the take down tubes. Plug unused holes. Take down tubes are shown in [Figs. A5.14 and A5.15](#).

6.11.2 *Laboratory Exhaust System*—The exhaust system specified is shown in [Fig. A5.13](#). Components can be clocked trimmed or modified as needed to ease installation, but install all components in the order shown. The laboratory has the discretion to design the system downstream differently than the location shown in [Fig. A5.13](#).

6.11.3 *Exhaust Back Pressure*—The exhaust system shall have the capability for controlling exhaust back pressure to the pressures specified in [Tables 2-4](#). The specified exhaust back pressure probe is shown in [Fig. A5.16](#), and the specified exhaust back pressure probe location in the exhaust system is shown in [Fig. A5.13](#).

6.12 *Pressure Measurement and Pressure Sensor Locations*—Pressure measurement systems for this test method are specified in general terms of overall accuracy and resolution with explicit pressure tap locations specified.

6.12.1 Incorporate condensation traps when connecting tubing between the pressure tap locations and the final pressure sensors as directed by good engineering judgment. This precaution is particularly important when low air pressures (as in this test method) are transmitted by way of lines that pass through low-lying trenches between the test stand and the instrument console.

6.12.2 *Engine Oil*—Locate the pressure tap for the engine oil pressure after the oil filter adapter. Use an accuracy of 1 % with a 6.9 kPa resolution.

6.12.3 *Fuel to Fuel Flowmeter*—Locate the pressure tap within 5 m from the fuel inlet of the fuel flow meter. Use an accuracy of 3.5 kPa.

6.12.4 *Fuel to Engine Fuel Rail*—Locate the pressure tap from the center point of the fuel rail inlet 235 mm \pm 30 mm. Use an accuracy of 3.5 kPa.

6.12.5 *Exhaust Back Pressure*—Locate the exhaust back pressure probe as shown in [Fig. A5.13](#). Use sensor accuracy to within 2 % of full scale with resolution of 25 Pa.

6.12.6 *Intake Air*—Measure the intake air pressure at the location shown in [Fig. A5.16](#). Use a sensor/readout accuracy of 2 % of full scale with resolution of 5.0 Pa.

6.12.7 *Intake Manifold Vacuum/Absolute Pressure*—Measure the intake manifold vacuum/absolute pressure at the throttle body adapter. Use a sensor having accuracy within 1 % of full scale and with a resolution of 0.68 kPa.

6.12.8 *Coolant Flow Differential Pressure*—See [6.5.9](#).

6.12.9 *Crankcase Pressure*—Locate the crankcase pressure tap as detailed in [Annex A14](#).

6.13 *Engine Hardware and Related Apparatus*—This section describes engine-related apparatus requiring special purchase, assembly, fabrication, or modification. Part numbers not otherwise identified are GM service part numbers.

6.13.1 *Test Engine Configuration*—The test engine is equipped with fuel injection, and is a 2009 GM (LY7, HFV6) OHT6D-099-3 with a displacement of 3.6 L. Purchase the engine (the 2008 GM (LY7), OHT6D-099-1, and 2009 GM (LY7) OHT6D-099-2 V-6 engine are no longer available from the CPD but are acceptable to use) as a test ready unit (for procurement, see [X1.3](#)). The only changes allowed from the as-received test ready unit is the installation of the fixed timing gears, modified camshaft position actuators, and coolant system orifice.

6.13.2 *ECU (Power Control Module)*—Use a special modified ECU Part No. OHT6D-012-4 engine power control module (see [X1.26](#)). This module controls ignition and fuel supply functions.

6.13.3 *Thermostat Block-off Adapter Plate*—Use an adapter plate OHT6D-004-1 as shown in [Fig. A5.5](#) in place of the thermostat.

6.13.4 *Wiring Harnesses*—Use a Dyno harness Part No. OHT6D-011-2, also included with the harness is an Engine Dyno Throttle Control OHT3H-011-1. Purchase from CPD (OH Technologies) (see [X1.28](#)).

6.13.5 *Oil Pan*—Use oil pan, Part No. OHT6D-001-1 (see [X1.23](#)).

6.13.6 *Engine Water Pump Adapter*—Purchase from the CPD, OHT6D-005-1 (see [X1.12](#)).

6.13.7 *Thermostat Block-Off-Plate*—Purchase from the CPD, OHT6D-004-1.

6.13.8 *Oil Filter Adapter Plate*—Purchase from the CPD, OHT6D-003-1.

6.13.9 *Modified Throttle Body Assembly*—Purchase from the CPD, OHT6D-050-1.

6.13.10 *Fuel Rail*—Purchase from the GM Parts Dealer Part No. 12572886. Modify the fuel rail inlet connections for connection to the laboratory fuel supply system.

6.14 *Miscellaneous Apparatus Related to Engine Operation:*

6.14.1 *Special Tools Purchase from the CPD:*

6.14.1.1 Flywheel Torque Tool, Purchase from the CPD, OHT3H-002-1 shown in [Fig. A5.18](#).

6.14.1.2 Balancer Torque Tool, Purchase from the CPD, OHT3H-003-1 shown in [Fig. A5.19](#).

6.14.2 *Additional Sensors and Other Hardware CPD:*

6.14.2.1 Mass Airflow Sensor, Purchase from the CPD, OHT6D-040-1.

6.14.2.2 Fuel Injectors, Purchase from the CPD, OHT6D-042-1.

6.14.2.3 Spark Plug, Purchase from the CPD, OHT6D-043-1.

6.14.2.4 Crank Position Sensor, Purchase from the CPD, OHT6D-044-1.

6.14.2.5 Cam Position Sensor, Purchase from the CPD, OHT6D-045-1.

6.14.2.6 Knock Sensor, Purchase from the CPD, OHT6D-046-1.

6.14.2.7 Coolant Temperature Sensor, Purchase from the CPD, OHT6D-048-1.

7. Reagents and Materials

7.1 *Engine Oil:*

7.1.1 Use VID BL (see [X1.2](#)) for new engine break-in and as primary calibration oil for evaluation of test oils. It is an SAE 20W-30 grade. The amount of BL oil required for each test is approximately 49 L.

7.1.2 Use VID BL Flush Oil (FO) (see [X1.2](#)), which is a special flushing oil (BL oil with increased solubility), when changing oil after a test oil has been in the engine. For each test use an FO volume of approximately 11 L.

7.2 *Test Fuel*—Use only Haltermann (see [X1.33](#)) HF 003 fuel. Specification for HF 003 fuel is contained in [Table 1](#). (**Warning**—Danger! Extremely flammable. Vapors harmful if inhaled. Vapors may cause flash fire (see [Annex A8](#)).)

7.2.1 Make certain that all tanks used for storage are clean before they are filled with test fuel.

7.2.2 *Fuel Batch Usage/Documentation*—A laboratory should strive to complete the test on a single batch of test fuel. If a laboratory is not able to complete a test on a single fuel batch, the laboratory can switch to the next available fuel batch. Fuel is consumed at the stand level on a first-in-first-out basis. Once a stand migrates to the next fuel batch, it can no longer use a prior batch. Document the fuel batch in use at the start of the test in the test report. In cases where the run tank contains more than one fuel batch, document the predominate fuel batch in the report.

7.3 *Engine Coolant*—The engine coolant shall be GM Dex-Cool⁴ at 100 %.

7.4 *Cleaning Materials:*

7.4.1 *Organic Solvent Penmul L460*—See [X1.29](#). (**Warning**—Harmful vapor. Store at moderate temperature (see [Annex A8](#))).

7.4.2 *Solvent*—Use only mineral spirits meeting the requirements of Specification [D235](#), Type II, Class C for Aromatic Content (0-2 vol %), Flash Point (61 °C, min) and Color (not darker than +25 on Saybolt Scale or 25 on Pt-Co Scale). (Combustible Health hazard.) Obtain a Certificate of Analysis for each batch of solvent from the supplier (see [X1.30](#)).

8. Preparation of Apparatus

8.1 This section assumes that the engine test stand facilities and hardware as described in Section 6 are in place. Emphasis is on the recurring preparations needed in the routine conduct of the test.

8.2 Test Stand Preparation:

8.2.1 *Instrumentation Preparation*—Perform the calibration of the temperature measuring system, the dynamometer torque measuring system, the fuel flow measuring system, and the pressure measuring system (see 10.2 for additional details concerning instrumentation calibration) in a manner consistent with good laboratory practices and record it for future reference.

8.2.2 *External Oil System Cleaning*—Clean the entire external oil system using cleaning solvent (see 7.4.2) each time a newly built engine is installed.

8.2.3 *Exhaust Back Pressure Probe Renewal*—The exhaust back pressure probe can be used until it becomes cracked, brittle, or deformed. Clean the outer surface of the probe and clear all port holes. Check the probe for possible internal obstruction and reinstall the probe in the exhaust pipe. Stainless steel probes are generally serviceable for several tests; mild steel probes tend to become brittle after fewer tests.

8.2.4 *AFR Sensor Renewal*—Inspect AFR sensor (see 10.2 for AFR system calibration requirements).

8.2.5 *Hose Replacement*—Inspect all hoses and replace any that are deteriorated. Check for internal wall separations that would cause flow restriction.

9. Engine Preparation

9.1 Purchase the engine OHT6D-099-3 as a test ready unit, purchase from CPD. The OHT6D-099-1 and the OHT6D-099-2 engines are no longer available from the CPD but are acceptable for use.

9.2 Stand set up kit, that contains engine mounts and other reusable parts, can be purchased from CPD, OHT6D-100-S1.

9.3 Cleaning of Engine Parts:

9.3.1 *Cleaning*—Soak any parts to be cleaned in degreasing solvent until clean.

9.3.2 *Rinsing*—Wash the parts thoroughly with hot water.

9.4 Engine Assembly Procedure:

9.4.1 *General Assembly Instructions*—Assemble the external engine dress components according to the detailed description in the 2008 VID Assembly Manual, a copy of which can be obtained from the ASTM TMC (see Annex A4) website. In cases of disparity, the explicit instructions contained in this test method take precedence over the assembly manual.

9.4.2 *Bolt Torque Specifications*—When installing the engine components, use a calibrated torque wrench to obtain the values specified. Specifications are shown in the 2008 VID Assembly Manual.

9.4.3 *Sealing Compounds*—Sealing compounds are as specified in the VID Engine Assembly Manual. Do not use sealers in tape form (loose shreds of tape can circulate in the engine oil and plug critical orifices).

9.4.4 New parts required for each new test stand installation (see X1.3) are listed in Annex A7.

9.4.5 *Harmonic Balancer*—The balancer Part No. GM 12603180 is included on the engine by the engine supplier.

9.4.6 *Thermostat*—Remove the thermostat and replace with special plate OHT6D-004-1.

9.4.7 *Coolant Inlet*—Install water pump plate OHT6D-005-1 (see X1.28).

9.4.8 *Oil Filter Adapter*—Install oil filter adapter Part No. OHT6D-003-1.

9.4.9 *Dipstick Tube*—Dipstick tube, Part No. GM 12612349 is included on the engine by the engine supplier.

9.4.10 Sensors, Switches, Valves, and Positioners:

9.4.10.1 *Camshaft Position Sensors (2 ea.) (CMP)*—Camshaft position sensors, OHT6D-045-1 (2) are included on the engine by the engine supplier.

9.4.10.2 *Crankshaft Position Sensor (CKP)*—Crankshaft position sensor, OHT6D-044-1 is included on the engine by the engine supplier.

9.4.10.3 *Engine Coolant Temperature Sensor (ECT)*—Install engine coolant temperature sensor, Part No. OHT6D-048-1.

9.4.10.4 *Heated Exhaust Gas Oxygen Sensors (HEGO)*—Use heated exhaust gas oxygen sensors, Part No. OHT6D-047-1. Ensure the HEGO's are correctly connected.

9.4.10.5 *PCV*—Remove the PCV valve and install OHT6D-013-1, vent all PCV points of connection to the crankcase pressure control system as detailed in Annex A14 and Fig. A5.17 (see 6.12.9). Plug all associated vacuum lines.

9.4.10.6 *Mass Air Flow Sensor*—Use mass air flow sensor, Part # OHT6D-040-1.

9.4.11 Ignition System:

9.4.11.1 *Ignition Coils*—GM 12618542 is included on the engine by the engine supplier.

9.4.11.2 *Spark Plugs*—Use spark plugs, OHT6D-043-1.

9.4.12 Fuel Injection System:

9.4.12.1 *Fuel Injectors*—Use fuel injectors, OHT6D-042-1. Refer to Annex A12 for injector flow specifications. Verification of each injector is required prior to use.

9.4.12.2 *Fuel Rail*—Install modified fuel rail, Part No GM 12572886 as modified in 6.12.4.

9.4.12.3 *Fuel Pressure Regulator*—Install a fuel pressure regulator. Paxton Model # 8F002-004 has been found to be suitable for this application (see X1.35).

9.4.13 *Intake Air System*—The engine intake air system components may be oriented according to laboratory requirement. However, use all of the specified components.

9.4.13.1 *Air Cleaner Housing (Air Box)*—Use GM 15147455 housing, and 19151528 lower cover. Use clamps 15147463 and 15147462 along with screws 11588831 as needed.

9.4.13.2 *Crankcase Ventilation Tube*—Plug crankcase ventilation tube on duct, GM 25733251.

9.4.13.3 *Air Cleaner Modification*—Modify the GM elbow #25733251 for the thermocouple and pressure taps (see Fig. A5.16).

9.4.13.4 *Air Cleaner Element*—Use air cleaner element, GM 25798271.

9.4.13.5 *Throttle Body*—Use two throttle bodies. OHT6D-050-1 with modified throttle linkage is installed on the engine.

A second throttle body Part No. OHT6D-041-1 (supplied with engine when purchased) is connected to the wiring harness and mounted at the stand.

9.4.13.6 *Throttle Body Air Duct*—Use throttle body air duct, GM 25733251.

9.4.14 *Engine Management System*—GM ECU E77 with Revision 3 software, part number OHT6D-012-4.

9.4.14.1 *Engine Wiring Harness*—Use a special engine/dyno wiring harness, Part No. OHT6D-011-2, purchase this part from the CPD (see [X1.34](#)).

9.4.14.2 *Engine Control Unit*—Use ECU engine control module, Part No. OHT6D-012-4, purchase this part from the CPD (see [X1.34](#)). This unit controls ignition and fuel supply functions.

(1) Supply the ECU power from a battery or a regulated power supply.

9.4.15 *Accessory Drive Units*—Do not use external drive units, including alternators, fuel pumps, power steering units, air pumps, air conditioning compressors, and so forth.

9.4.16 *Exhaust Manifolds*—Use exhaust manifolds, right hand GM # 12571102 and left hand GM # 12571101 and heat shields GM # 12617267 and GM # 12580706. Torque bolts in the sequence shown in the 2008 VID Assembly Manual.

9.4.17 *Engine Flywheel and Guards*—Use flywheel OHT6D-020-X (Lab specific adapter plate). Purchase this part from the CPD, install an engine flywheel guard and safety housing to suit test stand requirements.

9.4.18 *Lifting of Assembled Engines*—Do not lift assembled engines by the intake manifold since this is known to cause engine coolant leaks. Refer to 2008 VID Assembly Manual for proper lifting instructions and lift locations.

9.4.19 *Engine Mounts*—Engine mounts use OHT3H-026-1 front and OHT3H-025-1 rear (see [X1.35](#)).

9.4.20 *Non-Phased Camshaft Gears*—These gears (OHT6D-016-1 GEAR, CAMSHAFT, EXHAUST & OHT6D-017-1 GEAR, CAMSHAFT, INTAKE) will need to be installed by the end user prior to running the new engine break-in; they will be supplied with the engine when purchased. Install these gears in accordance with the instructions detailed in [Annex A17](#).

9.4.21 *Internal Coolant Orifice*—This orifice (OHT6D-025-1 Orifice, Coolant, Internal, Sequence VID) needs to be installed by the end user prior to running the new engine break-in. It will be supplied with the engine when purchased.

9.4.22 *Camshaft Position Actuator Modification*—For Sequence VID test operation, the camshaft position actuator shall be in place to provide lubrication to the front camshaft journals. Close, by tig welding, the actuator drain ports to reduce excessive oil bleeding through the control valves during engine operation as the valves are positioned in a manner that allows complete drainage through the spool valves (see [Fig. A2.21](#)).

10. Calibration

10.1 *Stand/Engine Calibration*—To ensure proper response to various oil parameters, conduct a reference oil test when a new or previously used test engine is installed in a test stand. This event is monitored by the TMC. See [Annex A2](#) prior to

attempting calibration of a new stand. The TMC assigns reference oils for calibration tests. These oils are formulated or selected to represent specific chemical types or performance levels or both. They are usually supplied directly to a testing laboratory under code numbers to ensure that the laboratory is not influenced by prior knowledge of acceptable results in assessing test results. Number each Sequence VID test to identify the stand number, the number of runs on that stand, the engine number, and the number of runs on the engine. For example, 56-21-3-8 defines a test on stand 56, which is test 21 on stand 56, engine number 3, and the 8th test on engine number 3. For reruns of operationally invalid or unacceptable reference oil tests, the stand run number shall be incremented by one and the engine run number shall be followed by the letter A for the first re-run, B for the second re-run, and so forth. For example, the next test number for an operationally invalid or unacceptable test would be 56-22-3-8A.

10.1.1 *Procedure*—Test stand/engine calibration is accomplished by conducting tests on TMC reference oils (see [Annex A2](#)).

10.1.1.1 Conduct reference oil tests on each test stand/engine combination within a laboratory according to TMC Lubricant Test Monitoring System (LTMS)⁹ guidelines. *Do not terminate a reference test due to an FEI result.*

10.1.1.2 The first three calibration periods on a given stand/engine combination are ten full-length non-reference oil tests or 1750 engine hours or 100 days, whichever occurs first.

10.1.1.3 Subsequent calibration periods on a given stand/engine combination are seven full-length non-reference oil tests or 1225 engine hours or 100 days, whichever occurs first.

10.1.1.4 If the elapsed time between Sequence VID tests on a stand/engine combination is more than 100 days EOT (end-of-test) to SOT (start-of-test), a minimum of one operationally valid, statistically acceptable reference oil test is required.

10.1.1.5 Re-reference the engines once removed from the test stand and re-installed, even if the test number and time criteria are met by the engine. Laboratories shall inform the TMC with a written explanation when a test engine is removed from a test stand and installed into another test stand. Only appropriate Sequence VID test engines (see [X1.3](#)) may be referenced.

10.1.1.6 The effective date of a reference test is the LTMS date and time of the reference test. Test start time is defined as the introduction of the reference oil into the engine, but the total test length shall include the BLB runs also. The LTMS date and time are defined as the date and time the test was completed (completion of the BL run following the reference oil) unless a different date and time are assigned by the TMC. The TMC may schedule more frequent reference oil tests (or approve less frequent reference oil tests) at its discretion. Under special circumstances (that is, extended downtime due to industry-wide parts or fuel outages) the TMC may extend

⁹ The Lubricant Test Monitoring System may be obtained from the ASTM Test Monitoring Center, 6555 Penn Avenue, Pittsburgh, PA 15206-4489, Attention: Administrator.

reference periods. Note non-reference oil tests conducted during the extended time allowance in the test note section of the report.

10.1.1.7 Failure of a reference oil test to meet Shewhart or Exponentially Weighted Moving Average (EWMA) control chart limits can be indicative of a false alarm, engine, test stand, or industry-related problem. When this occurs, the laboratory, in conjunction with the TMC, shall attempt to determine the problem source. The ASTM Sequence VI Surveillance Panel adjudicates industry problems. The TMC decides, with input as needed from industry expertise (testing laboratories, test procedure developer, ASTM Technical Guidance Committee, Surveillance Panel, and so forth), if the reason for any unacceptable blind reference oil test is isolated to one particular engine or stand or related to other stands. If it is decided that the problem is isolated to an individual engine or stand, calibrated testing on other stands may continue throughout the laboratory. The laboratory may elect to attempt additional reference oil tests in the same engine. In the event the engine does not attain calibration, the laboratory shall remove the engine and go through the normal process of calibrating a new engine. Include operationally valid, statistically unacceptable data on removed engines in all appropriate databases (industry reference oil severity and precision) unless the engine failing to calibrate is a new engine (has never been calibrated and conducted non-reference oil tests).

10.1.1.8 If non-standard tests are conducted on a calibrated engine or test stand, recalibrate the stand and engine prior to running standard tests.

10.1.2 *Reporting of Reference Results*—Upon completion of the reference oil test, the test laboratory transmits the data electronically to the TMC, as described in Section 13. The TMC reviews the data and contacts the laboratory engineer to report the laboratory’s calibration status. All reference oil test results, whether aborted, invalidated, or successfully completed, shall be reported to the TMC.

10.1.3 *BL Baseline Calibration Oil and BL-FO Flush Oil*—The Baseline Calibration (BL) Oil and BL-FO Flush Oil may be analyzed only to the extent required to evaluate the effectiveness of a test stand’s flushing system. This analysis will be limited to molybdenum content. Do not subject the BL oil or BL-FO oil to further physical or chemical analyses other than those specified within this procedure unless specifically authorized by the TMC. In such instances, supply written confirmation of the circumstances involved, the data to be obtained, and the name of the person requesting the analysis to the TMC.

10.2 *Instrument Calibration*—Document all instrument calibrations.

10.2.1 Upon initial stand installation and every six months thereafter perform a full instrumentation calibration according to Table 6.

10.2.2 Prior to each reference oil test sequence, or when introducing a new engine on an existing stand, perform a partial instrumentation calibration according to Table 7.

10.2.2.1 If a full instrumentation calibration is due at the same time, perform Table 6 calibrations instead of Table 7.

TABLE 6 Sequence VID Instrument Calibrations to be Performed every 6 Months

Temperatures
Intake Air, °C
Oil Gallery, °C
Oil Sump, °C
Coolant Inlet, °C
Coolant Out, °C
Fuel to Fuel Rail, °C
Fuel to Flowmeter, °C
Load Cell, °C
Pressures
Crankcase, kPa
Engine Oil, kPa
Fuel to fuel Rail, kPa
Fuel to Flowmeter, kPa
Exhaust Back Pressure, kPa (absolute)
Intake Air, kPa
Intake Manifold, kPa (absolute)
Flows
Air to Fuel Ratio
Coolant, L/min
Fuel Flow, kg/h
General
Intake Air Humidity, grains/kg
Speed, r/min
Torque, N·m (performed at beginning of every test)

TABLE 7 Sequence VID Instrument Calibrations to be Performed before Reference Tests

Flows
Fuel Flow, kg/h
Air to Fuel Ratio
Pressures
Exhaust Back Pressure, kPa (absolute)
General
Speed, r/min
Torque, N·m (performed at beginning of every test)

10.2.3 *Engine Torque Measurement System*—Use deadweights to calibrate at the start of a test and before each reference oil test. Prior to calibration, start the engine and run for a minimum of 30 min at 1500 r/min \pm 5 r/min, 70 N·m \pm 2 N·m. Shut the engine down, leave dynamometer cooling water on, and start performing the load cell calibration within 3 min after shutdown.

10.2.3.1 Perform the calibration at the 3 designated torques (approximately 26 N·m, 37 N·m, and 107 N·m. The stand load cell measurement system shall perform within \pm 0.3 N·m of the calibration standard.

10.2.4 *Fuel Flow Measurement System*—Use accurate mass scale measurements for calibrating. Perform this calibration at three fuel flow rates (approximately 1.0 kg/h, 4.0 kg/h, and 7.5 kg/h. Evaluate each flow rate a minimum of three times to verify repeatability. Adjust the results to compensate for evaporation.

10.2.4.1 The test stand flowmeter shall perform to within 0.25 % at 7.5 kg/h, 0.32 % at 4.0 kg/h, and 0.54 % at 1.0 kg/h of the calibration standard. For each flow rate, a minimum of three consecutive flow readings shall be within the specified

tolerance. The calibration standard shall be at least 4 times more accurate than the test stand flowmeter at each specified flow rate.

10.2.5 Coolant Flow Measurement System—Calibrate the flow measurement device as installed in the system at the test stand every six months. Starting September 26, 2012, and mandatory on or after January 1, 2013, the following is prescribed:

10.2.5.1 Calibrate the stand flow measurement device with a suitable flow measurement device using 100 % water as the calibration media.

10.2.5.2 Calibrate the flow measurement device used for calibration of the stand flow measurement device every 12 months using 100 % water as the calibration media and traceable to NIST.

10.2.6 Thermocouple and Temperature Measurement System—Check the calibration of the test stand temperature measurement system (thermocouple through readout) at the test stand using the existing readout system a minimum of once every six months. For the critical temperatures (see **Table 3**) the individual temperature sensors shall indicate within ± 0.56 °C of the laboratory calibration standards. The calibration equipment utilized shall be appropriate for the desired ± 0.56 °C accuracy level. See **6.9** for additional thermocouple calibration requirements.

10.2.7 Humidity Measurement System—Calibrate the primary laboratory measurement system at each stand a minimum of once every six months using a hygrometer with a minimum dew point accuracy of ± 0.55 °C at 16 °C. Locate the sample tap on the air supply line to the engine in the intake air cleaner.

10.2.7.1 The calibration consists of a series of paired humidity measurements comparing the laboratory system with the calibration hygrometer. The comparison period lasts from 20 min to 2 h with measurements taken at intervals of 1 min to 6 min, for a total of twenty paired measurements. The measurement interval shall be appropriate for the time constant of the humidity measuring instruments.

10.2.7.2 Verify that the flow rate is within the equipment manufacturer’s specification, and that the sample lines are non-hygroscopic. Correct dew point hygrometer measurements to standard conditions 101.12 kPa using the appropriate equation (see **6.8.1**). Compute the difference between each pair of readings and calculate the mean and standard deviation of the twenty paired readings, using **Eq A10.1** and **Eq A10.2** in **Annex A10**. The absolute value of the mean difference shall not exceed 1.43 g/kg, and the standard deviation shall not be greater than 0.714 g/kg. If these conditions are not met, investigate the cause, make repairs, and recalibrate. Maintain calibration records for two years.

10.2.8 Other Instrumentation—As a minimum, calibrate instrumentation for measuring parameters other than those detailed in **10.2.3 – 10.2.7** every six months. Calibration of the oil heater instrumentation is not required.

11. Test Procedure

11.1 External Oil System—Clean the external oil system each time a new engine is installed (see **8.2.2**). If this is a new test stand, demonstrate the flush effectiveness.

11.2 Flush Effectiveness Demonstration—A laboratory shall demonstrate the flush effectiveness of their flying flush oil system for any new stand and for any stand that has had modifications made to the oil system. By using an oil containing molybdenum at a minimum concentration of 400 mg/kg a laboratory shall demonstrate a flush effectiveness of 99 %, by Inductive Coupled Plasma (ICP), after the final flush of a detergent flush (see **11.6.2.1** when detergent flushing from the demonstration oil to BL oil. ASTM oil FEEO-103 (FEEO-103 available from TMC, see **X1.1**) has proven satisfactory for use in this demonstration. The procedure is as follows (FM = ASTM FEEO-103 (FM) or other suitable oil containing molybdenum):

11.2.1 With the engine already charged with BL oil, warm engine to Stage Flush (see **Table 4**).

11.2.2 Take a sample of the FM oil from the oil reservoir (Sample New Oil) of 118 mL.

11.2.3 Flush in FM oil, run 30 min.

11.2.4 Flush in FM oil, run 30 min.

11.2.5 Flush in FM oil (this completes the FM oil change).

11.2.6 Run 30 min, take a purge sample of 118 mL and pour back into the engine. Take a retain sample (Sample 1) of 118 mL.

11.2.7 Flush to FO Flush oil, run 30 min.

11.2.8 Flush to FO Flush oil, run 2 h, take a purge sample of 118 mL and pour back into the engine. Take a retain sample (Sample 2) of 118 mL.

11.2.9 Flush in BL oil, run 30 min, take a purge sample of 118 mL, pour back into engine. Take a retain sample (Sample 3) of 118 mL.

11.2.10 Flush in BL oil, run 30 min, take a purge sample of 118 mL and pour back into engine. Take a retain sample (Sample 4) of 118 mL.

11.2.11 Flush in BL oil, take a purge sample of 118 mL and pour back into engine. Take a retain sample (Sample 5) of 118 mL.

11.2.12 Analyze Samples—Analyze new oil, 1, 2, 3, 4, and 5 (Comparison is Sample **11.2.11** versus **11.2.6**) by ICP Test Method **D5185** for the molybdenum and report the results to TMC.

11.3 Preparation for Oil Charge—Check the apparatus carefully to be sure that all oil lines and fittings are properly tightened and aligned. This includes the apparatus for the flying flush oil change system.

11.4 Initial Engine Start-Up—Connect the fuel line to the engine fuel rail or open the fuel shut-off valves, or both. Ready the control console (engine ignition on, external oil circulation pump on, safety circuits ready). Crank the engine. When the engine is running at idle (approximately 700 r/min, zero torque), check for fuel, oil, coolant, water, and exhaust leaks.

11.5 New Engine Break-In—A broad overview of the new engine break-in is as follows:

11.5.1 Cyclical operation with BL oil is required for engine break-in for a minimum of 150 h. Hourly BSFC measurements are routinely recorded. The intense care for precision required for test operation is not required for cyclical break-in operation.

11.5.2 *Oil Charge for Break-In*—Service both oil filters to ensure that they are clean. Drain oil and charge the engine with fresh BL oil, adding 5.4 L.

11.5.2.1 *Oil Additions During Break-In*—Monitor oil pan level on an hourly basis, during Step A operation. When oil pan level reaches 400 mL below test full, add fresh BL oil to bring it back to the original test full level, using the same batch of BL used for initial break-in oil charge. Record oil addition amount and break-in hour that the addition was completed.

11.5.3 *Break-in Operating Conditions*—Follow the break-in schedule for new engines as shown in [Table 2](#). It is suggested that the cycling be a step function, rather than a ramp function. If a ramp function is used, take care to ensure that the ramp is not too mild, since too mild a ramp may not work the engine hard enough to successfully accomplish break-in.

11.5.4 *Stand Requirements for Break-In*—Do the engine break-in on a test stand that has a Midwest or Eaton 37 kW Model 758 dry gap dynamometer (see [X1.4](#)) and meets the specifications shown in [Table 2](#).

11.5.5 Provide ramp traces to the TMC for review prior to the assignment of the initial reference oil at (1, 75 and 149) h. When it is necessary to extend break-in beyond 150 h, provide a ramp trace taken prior to termination of break-in by 1 h. Record speed, MAP, and torque at a minimum of 1 s intervals.

11.6 Routine Test Operation:

11.6.1 *Start-Up and Shutdown Procedures*—In accomplishing a routine engine shutdown, disconnect the fuel lines or close the fuel valves for the fuel supply after the engine has been shut down.

11.6.1.1 *Unscheduled Shutdown and Restart*—There are no scheduled shutdown periods in the test. Continuous operation is expected from initial warm-up prior to flushing in the BL oil before test oil through the final testing of the BL oil segment after the test oil. If an unexpected shutdown does occur, the maximum allowable downtime per test is 18 h. Only four unscheduled shutdowns per test are allowed. Report all shutdowns and the amount of time per shut down in the downtime occurrence section of the final report. Report all other deviations in test time from the appropriate table in the comment section of the final report. Include details in these comments as to why the deviation occurred and the total time of the occurrence. If unexpected shutdowns occur, the following guidelines apply:

Testing Phase	Restart and Continuation Procedure
During Stabilization Runs	Return to start of current step.
During BSFC Measurement Runs	Re-accomplish the stabilization run in entirety and acquire all new BSFC data after the designated stabilization.
During Oil Flushes or During Test Oil Aging	Continue on existing schedule without deleting any of the prescribed operating time.

11.6.2 *Flying Flush Oil Exchange Procedures*—These flushing procedures involve oil exchanges without stopping the engine. In all cases, bring the engine to Stage Flush conditions (see [Table 4](#)) before initiating any flush.

11.6.2.1 *Detergent Flush (FO), Test Oil to BL Oil*—This procedure is intended to remove any residual effects from the previous oil and is performed when flushing from test oil to BL oil. Accomplish this detergent flush in the following steps:

(1) Heat the FO oil and BL oil external reservoirs within the range of 93 °C to 107 °C.

(2) Bring the engine to Stage Flush conditions (see [Table 4](#)).

(3) Switch external oil system to Flush Mode and allow the engine to draw FO Oil while oil is being scavenged from the oil sump. Note that the scavenge pump draws oil from the oil sump until the oil level in the dump tank reaches the 5.4 L level and the float level switch in the dump tank turns off the scavenge pump. When the scavenge pump is turned off, the solenoids switch so that oil starts circulating to the engine as the oil sump fills to 5.4 L. When the oil level in the sump reaches the full level of 5.4 L, the float level switch in the oil pan closes the solenoid to the oil reservoir and the oil then fully circulates to the engine.

(4) Allow the engine to continue running at Stage Flush conditions for 30 min.

(5) Re-accomplish Step 3 with FO oil.

(6) Allow the engine to continue running at Stage Flush conditions for 2 h.

(7) With BL oil at the specified temperature for flushing, switch to the BL oil reservoir and accomplish Step 3 with BL (flush, fill, run).

(8) Allow the engine to continue running at Stage Flush conditions for 30 min.

(9) Re-accomplish Step 3 with BL oil.

(10) Allow the engine to continue running at Stage Flush conditions for 30 min.

(11) Re-accomplish Step 3 with BL oil.

(12) After completing the flush and when Flush conditions are met, add or drain oil to achieve the engine full level.

(13) Return the engine to Stage 1 (see [Table 3](#)), and follow stabilization procedure for BSFC measurement with BL oil.

11.6.2.2 *Double Flush From BL Oil to Test Oil*—This procedure removes the previous oil and is performed when flushing from BL oil to test oil. This double flush is accomplished as follows:

(1) Heat the test oil in the external reservoir within the range of 93 °C to 107 °C.

(2) Bring the engine to Stage Flush conditions.

(3) Switch the external oil system to Flush Mode and allow the engine to draw non-reference oil while oil is being scavenged from the oil sump. Note that the scavenge pump will draw oil until the level in the oil dump tank reaches the 5.4 L level and the float level switch in the dump tank turns off the scavenge pump. When the scavenge pump is turned off, the solenoids switch so that oil starts recirculation to the engine as the sump fills to 5.4 L. When the oil level in the sump reaches the full level of 5.4 L, the float level switch in the oil pan closes the solenoid to the oil reservoir, and the oil fully recirculates to the engine.

(4) Allow the engine to continue running at Stage Flush conditions for 30 min.

(5) Re-accomplish Step 3.

(6) Allow the engine to continue running at Stage Flush conditions for 30 min.

(7) Re-accomplish Step 3.

(8) Bring the engine to Flush conditions.

(9) After completing the flush and when Flush conditions are met, add or drain oil to achieve the engine full level.

11.6.2.3 Double Flush From BLA Oil (Baseline After) to BLB1 Oil (Baseline Before Set 1)—This procedure removes the previous oil and is performed when flushing from BLA oil to BLB1 oil between oil tests. Accomplish this double flush as follows:

(1) Heat the BL oil in the external reservoir within the range of 93 °C to 107 °C.

(2) Bring the engine to Stage Flush conditions.

(3) Switch the external oil system to Flush Mode and allow the engine to draw BL oil while BL oil is being scavenged from the oil sump. Note that the scavenge pump will draw oil until the level in the oil dump tank reaches the 5.4 L level and the float level switch in the dump tank turns off the scavenge pump. When the scavenge pump is turned off, the solenoids switch so that oil starts recirculation to the engine as the sump fills to 5.4 L. When the oil level in the sump reaches the full level of 5.4 L, the float level switch in the oil pan closes the solenoid to the oil reservoir, and the oil fully recirculates to the engine.

(4) Allow the engine to continue running at Stage Flush conditions for 30 min.

(5) Re-accomplish Step 3.

(6) Allow the engine to continue running at Stage Flush conditions for 30 min.

(7) Re-accomplish Step 3.

(8) Return the engine to Stage 1, and follow the stabilization procedure for BSFC measurement with BL oil.

11.6.2.4 Double Flush From BLB1 Oil to BLB2 Oil—This procedure removes the previous oil and is performed when flushing from BLB1 oil to BLB2 oil between oil tests. Accomplish this double flush as follows:

(1) Heat the BL oil in the external reservoir within the range of 93 °C to 107 °C.

(2) Bring the engine to Stage Flush conditions.

(3) Switch the external oil system to Flush Mode and allow the engine to draw BL oil while BL oil is being scavenged from the oil sump. Note that the scavenge pump will draw oil until the level in the oil dump tank reaches the 5.4 L level and the float level switch in the dump tank turns off the scavenge pump. When the scavenge pump is turned off, the solenoids switch so that oil starts recirculation to the engine as the sump fills to 5.4 L. When the oil level in the sump reaches the full level of 5.4 L, the float level switch in the oil pan closes the solenoid to the oil reservoir, and the oil fully recirculates to the engine.

(4) Allow the engine to continue running at Stage Flush conditions for 30 min.

(5) Re-accomplish Step 3.

(6) Allow the engine to continue running at Stage Flush conditions for 30 min.

(7) Re-accomplish Step 3.

(8) Return the engine to Stage 1, and follow the stabilization procedure for BSFC measurement with BL oil.

(9) Compare total fuel consumption between BLB1 and BLB2. The percentage delta between BLB1 and BLB2 shall fall within -0.20% to $+0.40\%$. If total fuel consumption

percentage delta falls outside of these values, conduct BLB3 by repeating steps 1 through 9. If the percentage delta between BLB2 and BLB3 exceeds -0.20% to $+0.40\%$, investigate potential cause and restart test at BLB1.

11.6.3 Test Operating Stages—**Table 3** depicts the test operating conditions for the stages, and **Table 5** depicts the schedule of operation.

11.6.3.1 After an engine has been broken in and deemed an acceptable stand/engine combination by TMC, evaluate non-reference oils relative to BL oil. This entails comparing the mass of fuel consumed for test oil aged for 16 h and 84 h run at the six stages, with fuel consumed for the fresh BL oil run before and after the test oil.

11.6.4 Stabilization to Stage Conditions—After the flying flush to each oil (BL or test oil) and for the change to each stage, prior to beginning the BSFC measurement cycle a stabilization time is specified of 1 h. This time is that which elapses between initially changing the speed/torque/temperature set points and the beginning of the first BSFC measurement cycle for that stage. It, therefore, includes the time during which the temperatures are changing. Manage the speed, torque, coolant, and oil temperature control loops such that the processes are brought to the desired set points.

11.6.5 Stabilized BSFC Measurement Cycle—After the stabilization period of 1 h has elapsed for each stage, use data obtained every 1 s for each of six 5 min segments. Use the data obtained for each 5 min segment to provide average values for speed, torque and fuel flow for the 300 ± 10 samples. Use these values in the calculation of the BSFC for each segment. These 300 samples are snapshot readings and no averaging or filtering is allowed.

11.6.5.1 During the BSFC measurement cycle of a test, a stage restart may be conducted for any stage provided the average of any critical parameter, as detailed in **Table 3**, is projected to be out of the specified range for that stage, and provided the sixth reading of that stage has not been completed. If the sixth reading of any stage is completed, do not conduct a stage restart for that stage. Additionally, if the sixth reading of any stage is completed and a critical parameter average is out of the specified range for that stage, the test is considered invalid. Only one stage restart per stage as shown in **Table 5** and no more than 4 stage restarts within a test are allowed. Document each stage restart in the comments section.

11.6.6 BLB1 Oil Flush Procedure for BL Oil Before Test Oil Run 1—At the start of test, warm the engine to Stage Flush conditions (see **Table 4**) and flush the BL oil into the engine without shutting the engine down. The sequences of events for this flush are as follows (see **11.6.2.3**):

11.6.6.1 Warm engine to Stage Flush.

11.6.6.2 Double flush to BL oil.

11.6.6.3 Proceed with BL oil BSFC data acquisition.

11.6.7 BSFC Measurement of BLB1 Oil Before Test Oil—Run Stages 1 through 6 as detailed in **Table 3**. Obtain 6 BSFC measurements at each stage according to the Critical Data Acquisition Period as detailed in and **11.6.5**.

11.6.8 BLB2 Oil Flush Procedure for BL Oil Before Test Oil Run 2—At the start of test, warm the engine to Stage Flush conditions (see **Table 4**) and flush the BL oil into the engine

without shutting the engine down. The sequences of events for this flush are as follows (see 11.6.2.4):

11.6.8.1 Warm engine to Stage Flush.

11.6.8.2 Double flush to BL oil.

11.6.8.3 Proceed with BLB2 oil BSFC data acquisition.

11.6.9 *BSFC Measurement of BLB2 Oil Before Test Oil*—Run Stages 1 through 6 as detailed in Table 3. Obtain 6 BSFC measurements at each stage according to the Critical Data Acquisition Period as detailed in and 11.6.5.

11.6.10 *Percent Delta Calculation for BLB1 vs. BLB2*—Following the completion of BLB-2, calculate the Total Consumed (non-weighted) between these using the equations in A16.8.

11.6.10.1 Acceptable range for baseline between BLB1 & BLB2 is -0.20% to $+0.40\%$, if total fuel consumption percent delta between BLB2 and BLB1 exceeds -0.20% to $+0.40\%$, a third BLB3 shall be run.

11.6.10.2 If the calculated percentage delta between BLB2 and BLB3 exceeds -0.20% to $+0.40\%$, shutdown the test and investigate potential cause and restart test at BLB1.

11.6.11 *Test Oil Flush Procedure*—After the BL oil before test oil segment is completed, flush the test oil into the engine without shutting the engine down. The sequences of events for this flush are as follows (see 11.6.2.2):

11.6.11.1 Double flush to test oil.

11.6.11.2 Adjust test oil to full mark at stage flush conditions. No oil additions are allowed after the first hour of aging.

11.6.11.3 Proceed with test oil aging.

11.6.12 *Test Oil Aging, Phase I*—Run at the aging conditions shown in Table 4 for 16 h. This 16 h interval starts when the double flush procedure is completed. The maximum allowable off-test-time during Phase I Aging is 2 h. If off-test time exceeds 2 h, the test is invalid. At the completion of the Phase I aging, run the first of two fuel economy measurements on the test oil.

11.6.13 *BSFC Measurement of Aged (Phase I) Test Oil*—After Aging Phase I (16 h) has completed, run Stages 1 through 6 as detailed in Table 3. Obtain 6 BSFC measurements at each stage according to the Critical Data Acquisition Period as detailed 11.6.5.

11.6.14 *Test Oil Aging, Phase II*—Run at the aging conditions shown in Table 4 for 84 h. The maximum allowable off-test-time during Phase II Aging is 2 h. If off-test time exceeds 2 h, the test is invalid. At the completion of the Phase II aging, run the second of two fuel economy measurements on the test oil.

11.6.15 *BSFC Measurement of Aged (Phase II) Test Oil*—After Aging Phase II (84 h) has completed, run Stages 1 through 6 as detailed in Table 3. Obtain 6 BSFC measurements at each stage according to the Critical Data Acquisition Period as detailed in 11.6.5.

11.6.15.1 *Oil Consumption During Aging*—Monitor test oil consumption during the aging period of 84 h by observing the running oil level in the engine oil sight glass. Final oil consumption is recorded at the completion of the second fuel economy measurement (Phase II) once the engine is stable in the Flush conditions.

11.6.16 *Oil Consumption and Sampling*—Once Phase II FEI Stage 6 is completed the test will go to Flush conditions; once it is stabilized, record the oil consumption prior to the first flush. The maximum allowable oil consumption for reference and non-reference oil tests is 1400 mL. After recording the oil level, take a 120 mL sample from the outlet (top) of the oil heater for viscosity measurement (see 13.17).

11.6.17 *Flush Procedure for BL Oil (BLA) After Test Oil*—After the test oil segment of the test is completed, flush FO oil into the engine without shutting the engine down. The sequence of events for flush is shown in 11.6.2.1.

11.6.17.1 FO to BL oil.

11.6.17.2 Proceed with BL oil BSFC data acquisition.

11.6.17.3 *BSFC Measurement of BL Oil After Test Oil*—Run Stages 1 through 6 as detailed in Table 3. When the BLA Test Oil is completed, calculate the BL shift as follows: Using unweighted, total fuel consumption data, BL shift after = BLB2-BLA/BLB2.

11.6.18 *General Test Data Logging Forms*—Forms used for recording data are left up to the laboratory's discretion.

11.6.19 *Diagnostic Review Procedures*—To ensure test operational validity, conduct a critical review of the data at frequent intervals during the test. The final review after the test is completed is only partially effective in identifying problems since the indicated data cannot be cross examined by first hand observation. Early detection of instrumentation errors is essential and often the record for information parameters (dependent variables) indicate problem areas involving the primary control parameters. The following parameter response characteristics are significant:

11.6.19.1 Stabilization trends.

11.6.19.2 Air fuel ratio stability.

11.6.19.3 Fuel flow stability.

11.6.19.4 Intake manifold absolute pressure.

11.6.19.5 Speed.

11.6.19.6 Torque.

11.6.19.7 Exhaust back pressure.

11.6.19.8 Fuel rail temperature.

12. Determination of Test Results

12.1 *FEI1 and FEI2 Calculations*:

12.1.1 Calculate the test results as detailed in Annex A15.

13. Report

13.1 For reference oil results, use the standardized report form set available from the ASTM TMC and data dictionary for reporting test results and for summarizing operational data.

NOTE 3—Report the non-reference oil test results on these same forms if the results are intended to be submitted as candidate oil results against a specification.

13.1.1 Fill out the report forms according to the formats shown in the data dictionary.

13.1.2 Transmit results to the TMC within 5 working days of test completion.

13.1.3 Transmit the results electronically as described in the ASTM Data Communications Committee Test Report Transmission Model (Section 2 — Flat File Transmission Format) available from the ASTM TMC. Upload files via the TMC's website.

13.2 All reference oil test results, whether aborted, invalidated, or successfully completed, shall be reported to the TMC.

13.3 *Deviations from Test Operational Limits*—All deviations from specified test shall be reported.

13.4 *Precision of Reported Units*—Use the Practice E29 rounding off method for critical pass/fail test result data. Report the data to the same precision as indicated in data dictionary. (13.1.1)

13.5 In the space provided, note the time, date, test hour, and duration of any shutdown or off-test condition. Document the outcome of all prior reference oil tests from the current calibration sequence that were operationally or statistically invalid.

13.6 If a calibration period is extended beyond the normal calibration period length, make a note in the comment section and attach a written confirmation of the granted extension from the TMC to the test report. List the outcomes of previous runs that may need to be considered as part of the extension in the comment section.

13.7 *Validity Statement*—Include a statement pertaining to the validity of the test at the bottom of the appropriate form, that is signed by the person responsible for conducting the test.

13.8 *BL Before 1 and 2 Start Dates*—The BL before 1 and 2 start dates are defined as the date when the BL before test oil(s) flush enters into the engine.

13.9 *BL Before Start Time*—The BL before start time(s) are defined as the time when the BL before test oil(s) flush enters into the engine.

13.10 *Test Oil Start Date*—This is defined as the date when the first non-reference or reference test oil flush enters into the engine.

13.11 *Test Oil Start Time*—This is defined as the time when the first non-reference or reference test oil flush enters into the engine.

13.12 *BL After Test Oil Start Date*—The BL after test oil start date is defined as the date when the FO test oil flush enters into the engine.

13.13 *BL After Test Oil Start Time*—The BL after test oil start time is defined as the time when the FO test oil flush enters into the engine.

13.14 *Total Engine Hours at End of Test*—This is defined as the cumulative engine hours at the completion of BL After Test Oil.

13.15 *Total Test Length*—This is defined as the total test hours accumulated from BLB1 time/date through the completion of BLA Stage 6.

13.16 *Fuel Batch*—This is defined as the batch number for the most recent batch of fuel that has been put into the fuel tank (it is recognized that in most cases a fuel tank will not be completely empty before a new load of fuel is put into the tank, so the fuel in the tank may actually be a mixture of two or more batches).

13.17 *Oil Viscosity Measurement*—Measure and report viscosity determinations at 40 °C and 100 °C on the appropriate form for New Oil and for Aged (Phase II) Oil. Make the viscosity determinations according to Test Method D445.

14. Precision and Bias¹⁰

14.1 *Precision*—Test precision is established on the basis of reference oil test results (for operationally valid tests) monitored by the TMC.³ The data are reviewed semi-annually by the Sequence VI Surveillance Panel. Contact the TMC for current industry data. Precision data for non-reference oils are reviewed semi-annually by the ASTM Sequence VI Surveillance Panel.

14.1.1 Test precision as established for the official acceptance of this procedure is shown in Table 8.

14.1.2 *Intermediate Precision Conditions*—Conditions where test results are obtained with the same test method using the same test oil, with changing conditions such as operators, measuring equipment, test stands, test engines, and time.

NOTE 4—Intermediate precision is the appropriate term for this test method rather than repeatability, which defines more rigorous within-laboratory conditions.

14.1.2.1 *Intermediate Precision Limit (i.p.)*—The difference between two results obtained under intermediate precision conditions that would in the long run, in the normal and correct conduct of the test method, exceed the values shown in Table 8 in only one case in twenty. When only a single test result is available, the Intermediate Precision Limit can be used to calculate a range (test result ± Intermediate Precision Limit) outside of which a second test would be expected to fall about one time in twenty.

14.1.3 *Reproducibility Conditions*—Conditions where test results are obtained with the same test method using the same test oil in different laboratories with different operators using different equipment.

14.1.3.1 *Reproducibility Limit (R)*—The difference between results obtained under reproducibility conditions that would, in the long run, in the normal and correct conduct of the test method, exceed the values in Table 8 in only one case in twenty. When only a single test result is available, the Reproducibility Limit can be used to calculate a range (test result ± Reproducibility Limit) outside of which a second test would be expected to fall about one time in twenty.

¹⁰ Supporting data have been filed at ASTM International Headquarters and may be obtained by requesting Research Report RR:D02-1678.

TABLE 8 Sequence VID Reference Oil Precision Statistics^A

Variable Fuel Economy Improvement, %	Intermediate Precision		Reproducibility	
	$s_{i.p.}^B$	i.p.	s_R^B	R
at 16 h	0.13	0.36	0.16	0.45
at 100 h	0.14	0.39	0.17	0.40

^A These statistics are based on results obtained on Sequence VID matrix oils GF5A, GF5B, GF5C, GF5D and GF5X, 540, 541-1, 542, 542-1, 542-2 and reference oil 1010 over the period Jan. 18, 2009 through July 6, 2015.

^B s = standard deviation.

14.2 *Bias*—Bias is determined by applying an acceptable statistical technique to reference oil test results and when a significant bias is determined, a severity adjustment is permitted for non-reference oil test results.

15. Keywords

15.1 aged test oil; brake specific fuel consumption; break-in; calibration oil; flying flush; fuel economy; reference oil; sequence VID; spark-ignition automotive engine

ANNEXES

(Mandatory Information)

A1. ASTM TEST MONITORING CENTER ORGANIZATION

A1.1 *Nature and Functions of the ASTM Test Monitoring Center (TMC)*—The TMC is a non profit organization located in Pittsburgh, Pennsylvania and is staffed to: administer engineering studies; conduct laboratory inspections; perform statistical analyses of reference oil test data; blend, store, and ship reference oils; and provide the associated administrative functions to maintain the referencing calibration program for various lubricant tests as directed by ASTM Subcommittee D02.B0 and the ASTM Executive Committee. The TMC coordinates its activities with the test sponsors, the test developers, the surveillance panels, and the testing laboratories. Contact TMC through the TMC Director at:

ASTM Test Monitoring Center
6555 Penn Avenue
Pittsburgh, PA 15206-4489
www.astmtmc.cmu.edu

A1.2 *Rules of Operation of the ASTM TMC*—The TMC operates in accordance with the ASTM Charter, the ASTM Bylaws, the Regulations Governing ASTM Technical Committees, the Bylaws Governing ASTM Committee D02, and the Rules and Regulations Governing the ASTM Test Monitoring System.

A1.3 *Management of the ASTM TMC*—The management of the Test Monitoring System is vested in the Executive Committee elected by Subcommittee D02.B0. The Executive Committee selects the TMC Director who is responsible for directing the activities of the TMC.

A1.4 *Operating Income of the ASTM TMC*—The TMC operating income is obtained from fees levied on the reference oils supplied and on the calibration tests conducted. Fee schedules are established by the Executive Committee and reviewed by Subcommittee D02.B0.

A2. ASTM TEST MONITORING CENTER: CALIBRATION PROCEDURES

A2.1 *Reference Oils*—These oils are formulated or selected to represent specific chemical, or performance levels, or both. They are usually supplied directly to a testing laboratory under code numbers to ensure that the laboratory is not influenced by prior knowledge of acceptable results in assessing test results. The TMC determines the specific reference oil the laboratory shall test.

A2.1.1 *Reference Oil Data Reporting*—Test laboratories that receive reference oils for stand calibration shall submit data to the TMC on every sample of reference oil they receive. If a shipment contains any missing or damaged samples, the laboratory shall notify the TMC immediately.

A2.2 *Calibration Testing:*

A2.2.1 Full scale calibration testing shall be conducted at regular intervals. These full scale tests are conducted using coded reference oils supplied by the TMC. It is a laboratory's responsibility to keep the onsite reference oil inventory at or above the minimum level specified by the TMC test engineers.

A2.2.2 *Test Stands Used for Non Standard Tests*—If a non standard test is conducted on a previously calibrated test stand, the laboratory shall conduct a reference oil test on that stand to demonstrate that it continues to be calibrated, prior to running standard tests.

A2.3 *Reference Oil Storage*—Store reference oils under cover in locations where the ambient temperature is between $-10\text{ }^{\circ}\text{C}$ and $+50\text{ }^{\circ}\text{C}$.

A2.4 *Analysis of Reference Oil*—Unless specifically authorized by the TMC, do not analyze TMC reference oils, either physically or chemically. Do not resell ASTM reference oils or supply them to other laboratories without the approval of the TMC. The reference oils are supplied only for the intended purpose of obtaining calibration under the ASTM Test Moni-

toring System. Any unauthorized use is strictly forbidden. The testing laboratory tacitly agrees to use the TMC reference oils exclusively in accordance with the TMC's published Policies for Use and Analysis of ASTM Reference Oils, and to run and report the reference oil test results according to TMC guidelines. Additional policies for the use and analysis of ASTM Reference Oils are available from the TMC.

A2.5 *Conducting a Reference Oil Test*—When laboratory personnel are ready to run a reference calibration test, they shall request an oil code via the TMC website.

A2.6 *Reporting Reference Oil Test Results*—Upon completion of the reference oil test, the test laboratory transmits the data electronically to the TMC, as described in Section 13. The TMC reviews the data and contacts the laboratory engineer to report the laboratory's calibration status. All reference oil test results, whether aborted, invalidated, or successfully completed, shall be reported to the TMC.

A2.6.1 All deviations from the specified test method shall be reported.

A3. ASTM TEST MONITORING CENTER: MAINTENANCE ACTIVITIES

A3.1 *Special Reference Oil Tests*—To ensure continuous severity and precision monitoring, calibration tests are conducted periodically throughout the year. Occasionally, the majority or even all of the industry's test stands will conduct calibration tests at roughly the same time. This could result in an unacceptably large time frame when very few calibration tests are conducted. The TMC can shorten or extend calibration periods as needed to provide a consistent flow of reference oil test data. Adjustments to calibration periods are made such that laboratories incur no net loss or gain in calibration status.

A3.2 *Special Use of the Reference Oil Calibration System*—The surveillance panel has the option to use the reference oil system to evaluate changes that have potential impact on test severity and precision. This option is only taken when a program of donated tests is not feasible. The surveillance panel and the TMC shall develop a detailed plan for the test program. This plan requires all reference oil tests in the program to be completed as close to the same time as possible, so that no laboratory/stand calibration status is left pending for an excessive length of time. In order to maintain the integrity of the reference oil monitoring system, each reference oil test is conducted so as to be interpretable for stand calibration. To facilitate the required test scheduling, the surveillance panel may direct the TMC to lengthen and shorten reference oil calibration periods within laboratories such that the laborato-

ries incur no net loss or gain in calibration status. To ensure accurate stand, or laboratory, or both severity assessments, conduct non reference oil tests the same as reference oil tests.

A3.3 *Donated Reference Oil Test Programs*—The surveillance panel is charged with maintaining effective reference oil test severity and precision monitoring. During times of new parts introductions, new or re blended reference oil additions, and procedural revisions, it may be necessary to evaluate the possible effects on severity and precision levels. The surveillance panel may choose to conduct a program of donated reference oil tests in those laboratories participating in the monitoring system, in order to quantify the effect of a particular change on severity and precision. Typically, the surveillance panel requests its panel members to volunteer enough reference oil test results to create a robust data set. Broad laboratory participation is needed to provide a representative sampling of the industry. To ensure the quality of the data obtained, donated tests are conducted on calibrated test stands. The surveillance panel shall arrange an appropriate number of donated tests and ensure completion of the test program in a timely manner.

A3.4 *Intervals Between Reference Oil Tests*—Under special circumstances, such as extended downtime caused by industry wide parts or fuel shortages, the TMC may extend the intervals between reference oil tests. Such extensions shall not exceed one regular calibration period.

A3.5 Introducing New Reference Oils—Reference oils produce various results. When new reference oils are selected, participating laboratories will be requested to conduct their share of tests to enable the TMC to recommend industry test targets. ASTM surveillance panels require a minimum number of tests to establish the industry test targets for new reference oils.

A3.6 TMC Information Letters—Occasionally it is necessary to revise the test method, and notify the test laboratories of the change, prior to consideration of the revision by Subcommittee D02.B0. In such a case, the TMC issues an Information Letter. Information Letters are balloted semi annually by Subcommittee D02.B0, and subsequently by D02. By this means, the Society due process procedures are applied to these Information Letters.

A3.6.1 Issuing Authority—The authority to issue an Information Letter differs according to its nature. In the case of an Information Letter concerning a part number change which

does not affect test results, the TMC is authorized to issue such a letter. Long term studies by the surveillance panel to improve the test procedure through improved operation and hardware control may result in the issuance of an Information Letter. If obvious procedural items affecting test results need immediate attention, the test sponsor and the TMC issue an Information Letter and present the background and data supporting that action to the surveillance panel for approval prior to the semiannual Subcommittee D02.B0 meeting.

A3.7 TMC Memoranda—In addition to the Information Letters, supplementary memoranda are issued. These are developed by the TMC and distributed to the appropriate surveillance panel and participating laboratories. They convey such information as batch approvals for test parts or materials, clarification of the test procedure, notes and suggestions of the collection and analysis of special data that the TMC may request, or for any other pertinent matters having no direct effect on the test performance, results, or precision and bias.

A4. ASTM TEST MONITORING CENTER: RELATED INFORMATION

A4.1 New Laboratories—Laboratories wishing to become part of the ASTM Test Monitoring System will be requested to conduct reference oil tests to ensure that the laboratory is using the proper testing techniques. Information concerning fees, laboratory inspection, reagents, testing practices, appropriate committee membership, and rater training can be obtained by contacting the TMC Director.

A4.2 Information Letters: COTCO Approval—Authority for the issuance of Information Letters was given by the committee on Technical Committee Operations in 1984, as

follows: “COTCO recognizes that D02 has a unique and complex situation. The use of Information Letters is approved providing each letter contains a disclaimer to the affect that such has not obtained ASTM consensus. These Information Letters should be moved to such consensus as rapidly as possible.”

A4.3 Precision Data—The TMC determines the precision of test methods by analyzing results of calibration tests conducted on reference oils. Precision data are updated regularly. Current precision data can be obtained from the TMC.

A5. DETAILED SPECIFICATIONS AND DRAWINGS OF APPARATUS

A5.1 Figs. A5.1-A5.21 present the detailed specifications and drawings of apparatus.

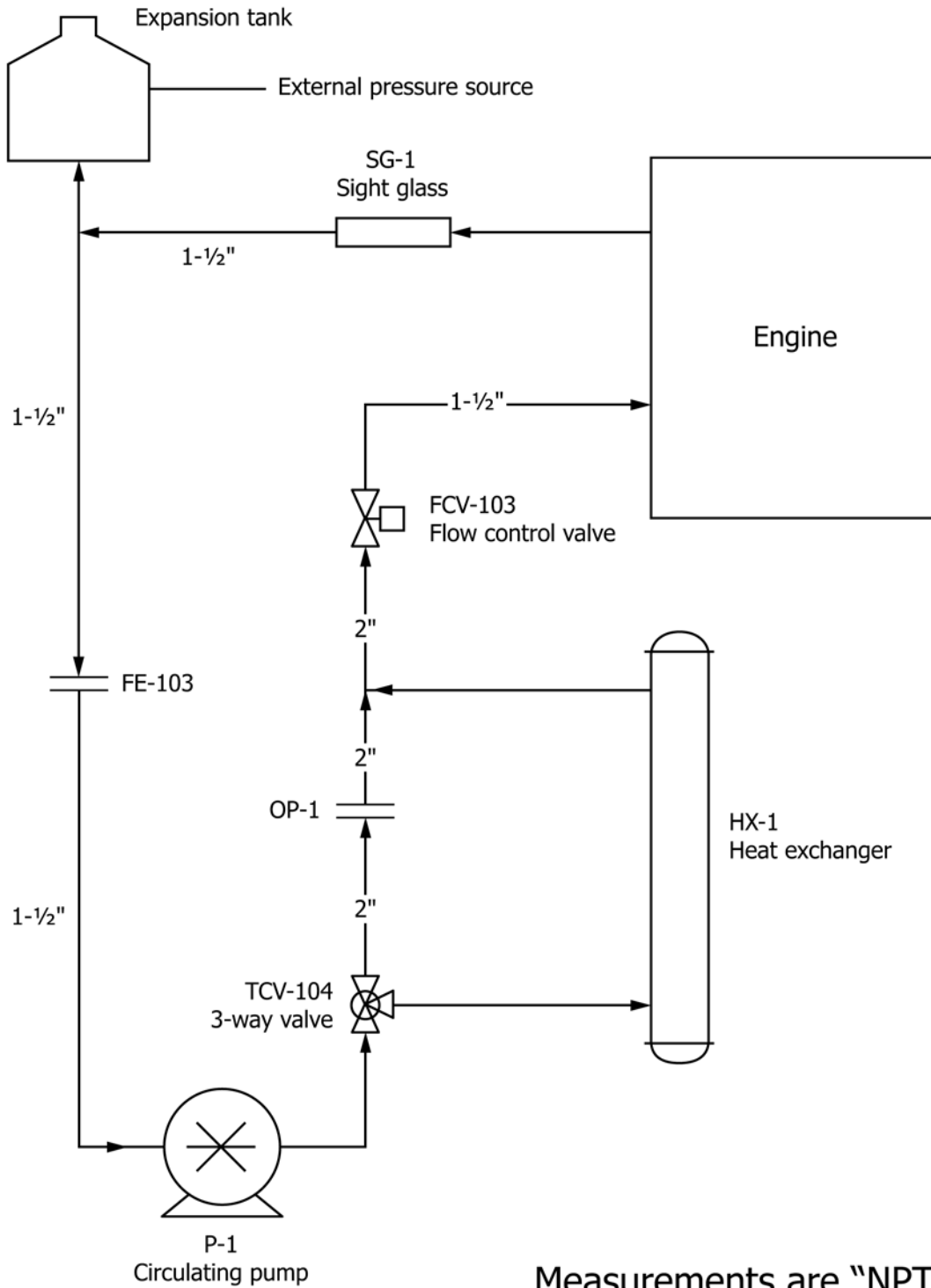
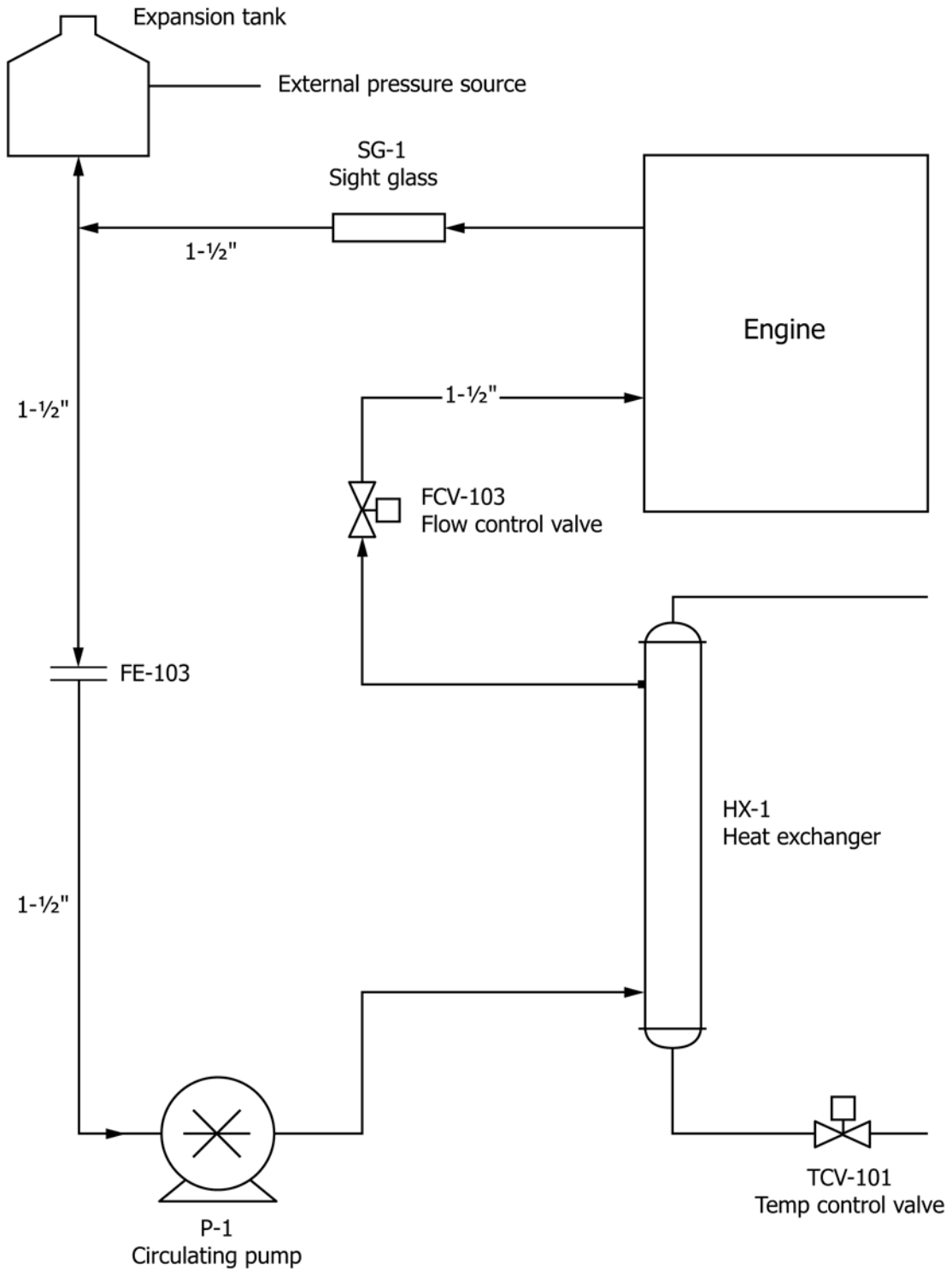
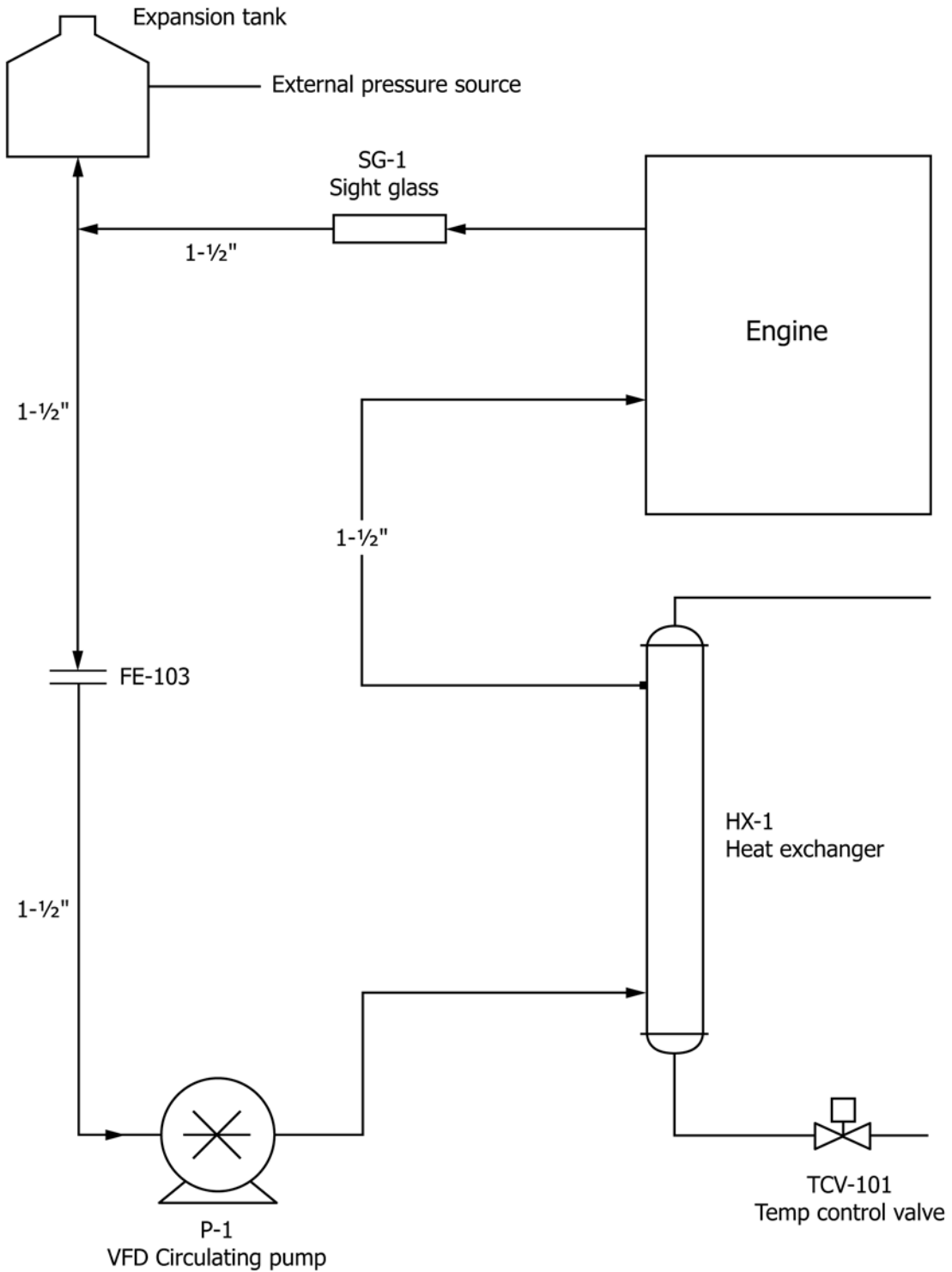

FIG. A5.1 Typical Engine Cooling System



Measurements are "NPT"

FIG. A5.2 Alternate Cooling System



Measurements are "NPT"

FIG. A5.3 Alternative Cooling System With VFD



FIG. A5.4 Water Pump Plate



FIG. A5.5 Coolant System Block-off Plate

Normal Operating Mode

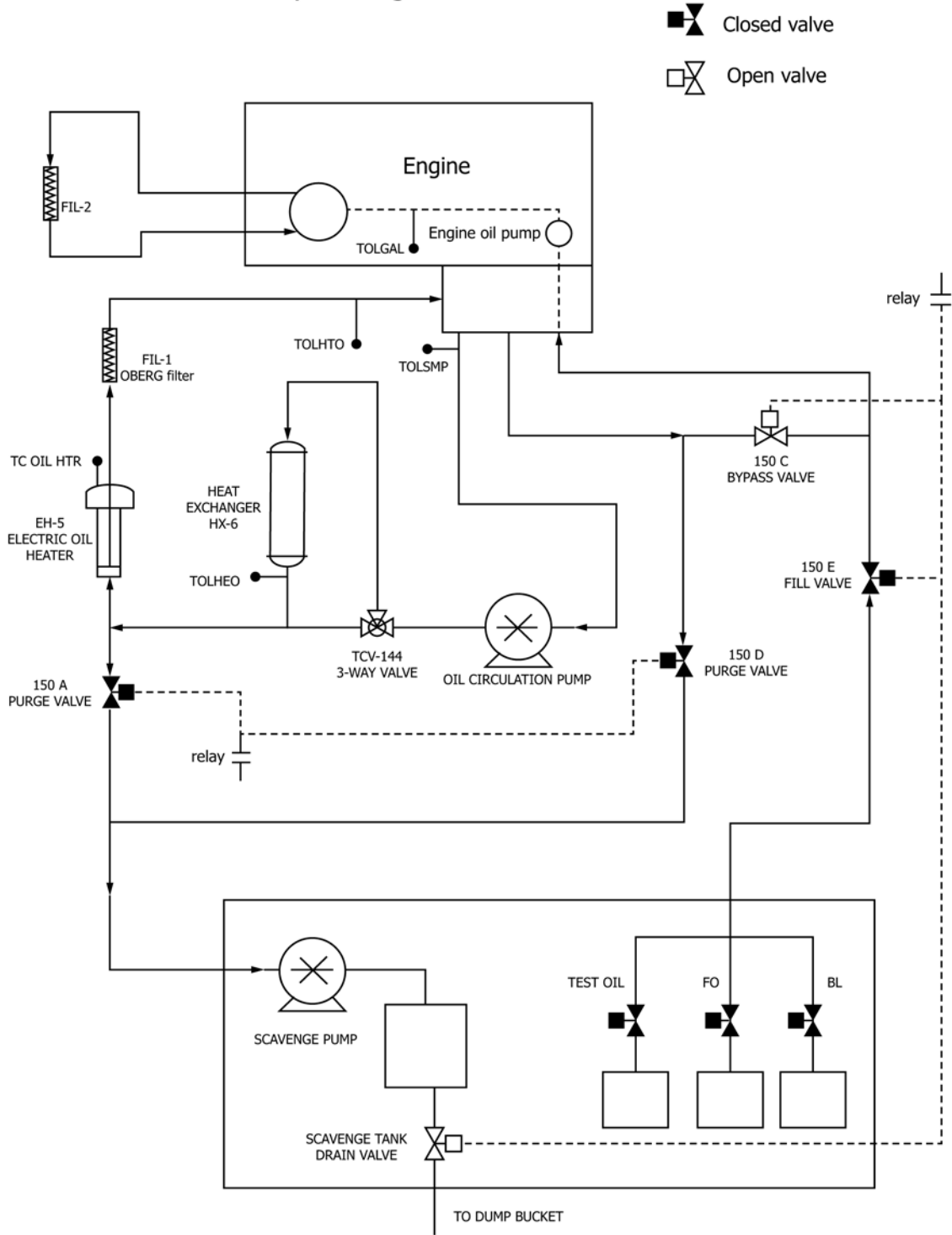
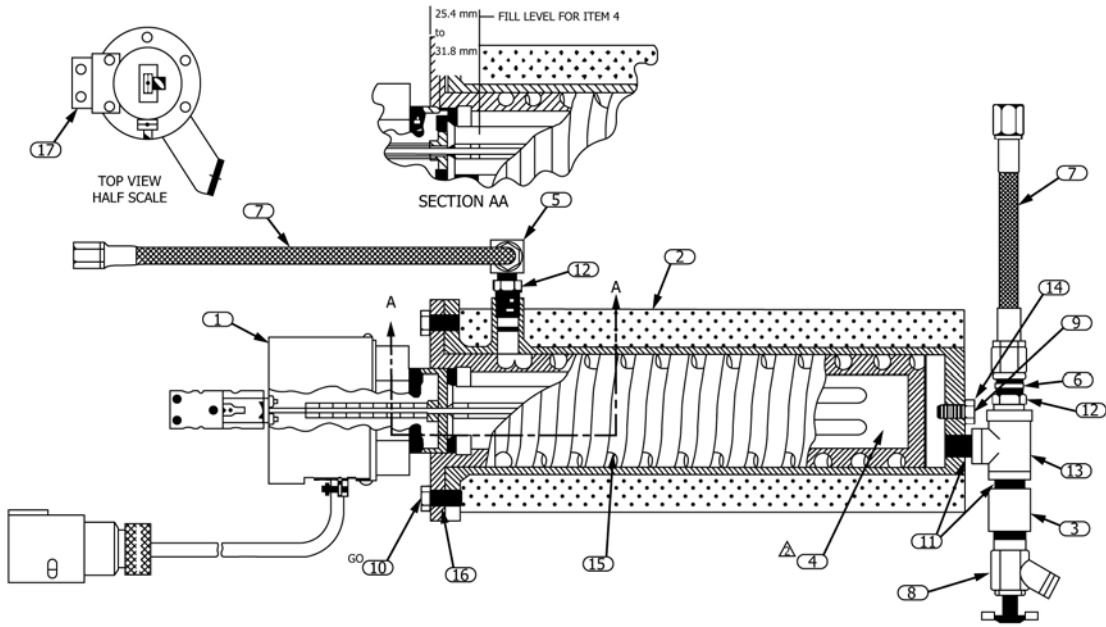

FIG. A5.6 External Oil System



- 3. TWO ROWS X NOT ASSEMBLED
- △ Fill with approximately 5.47 kg of Cerro Base
- 1. Oil Capacity 425-475 ml including hose and fillings shown

FIG. A5.7 Thermocouple in Oil Heater

FOLD FROM ABOUT 1.27 TO 1.52 STAINLESS STEEL AND WELD ALL JOINT SO CONTAINER HOLDS LIQUID.

TOP GETS A HINGED TRANSPARENT PLASTIC COVER TO CONTAIN FUMES.

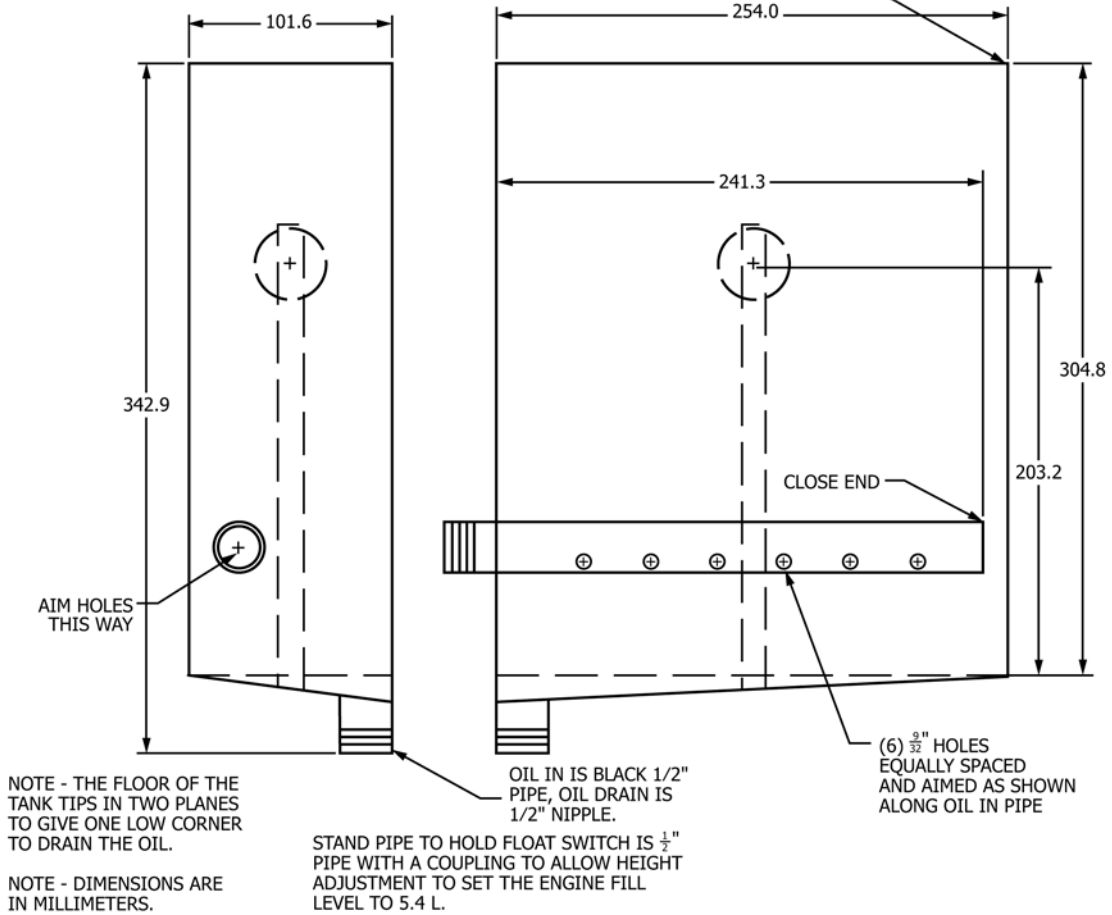

FIG. A5.8 Typical Oil Dump Tank

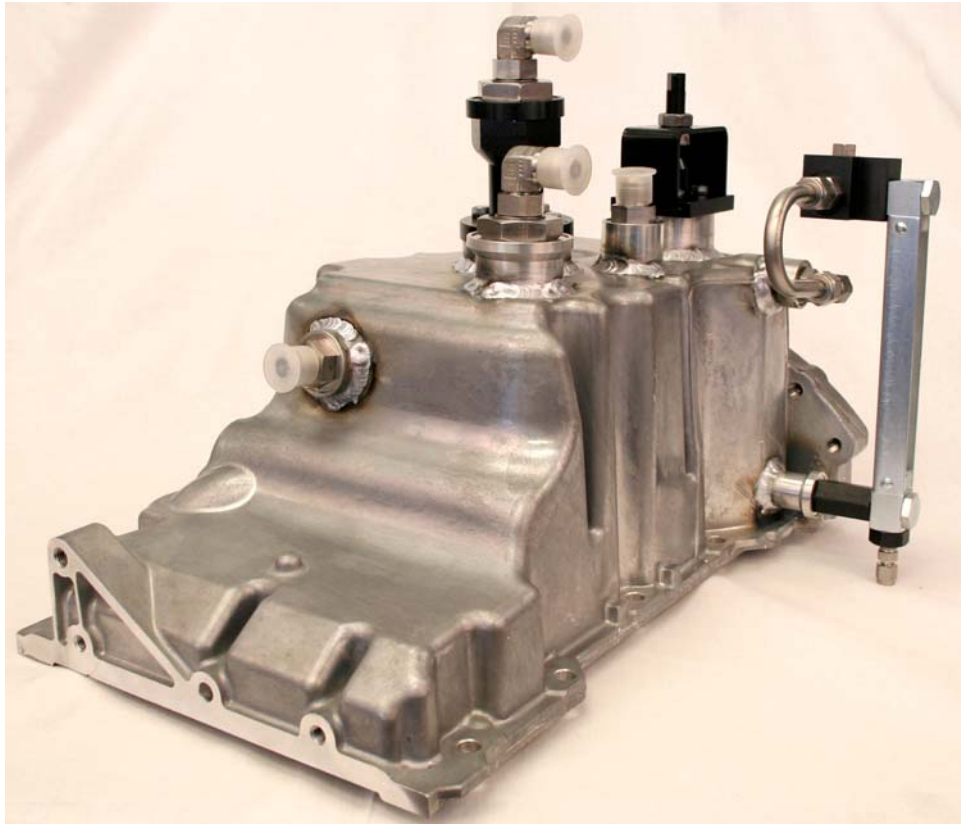

FIG. A5.9 Sequence VID Pan Modifications

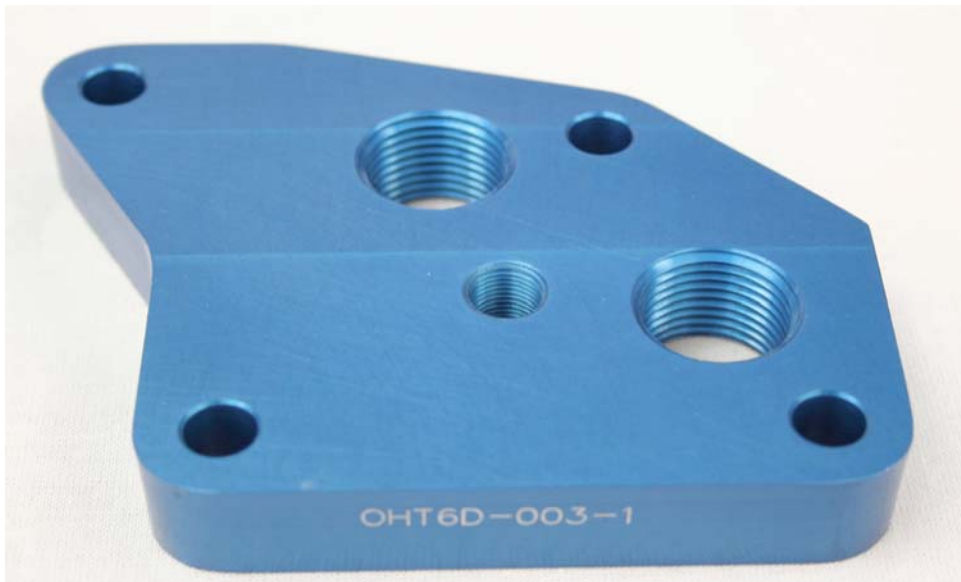

FIG. A5.10 Oil Filter Adapter Assembly

Position VI D Fuel System Diagram

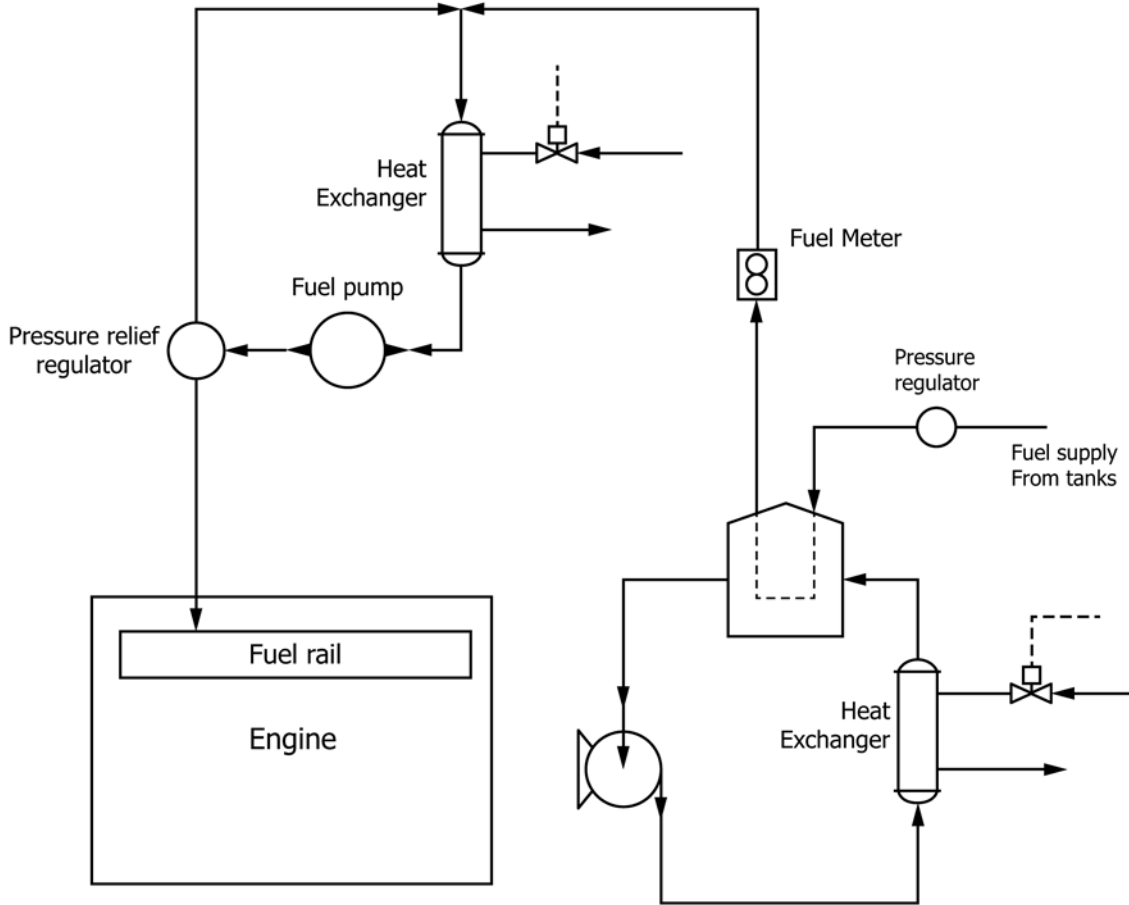
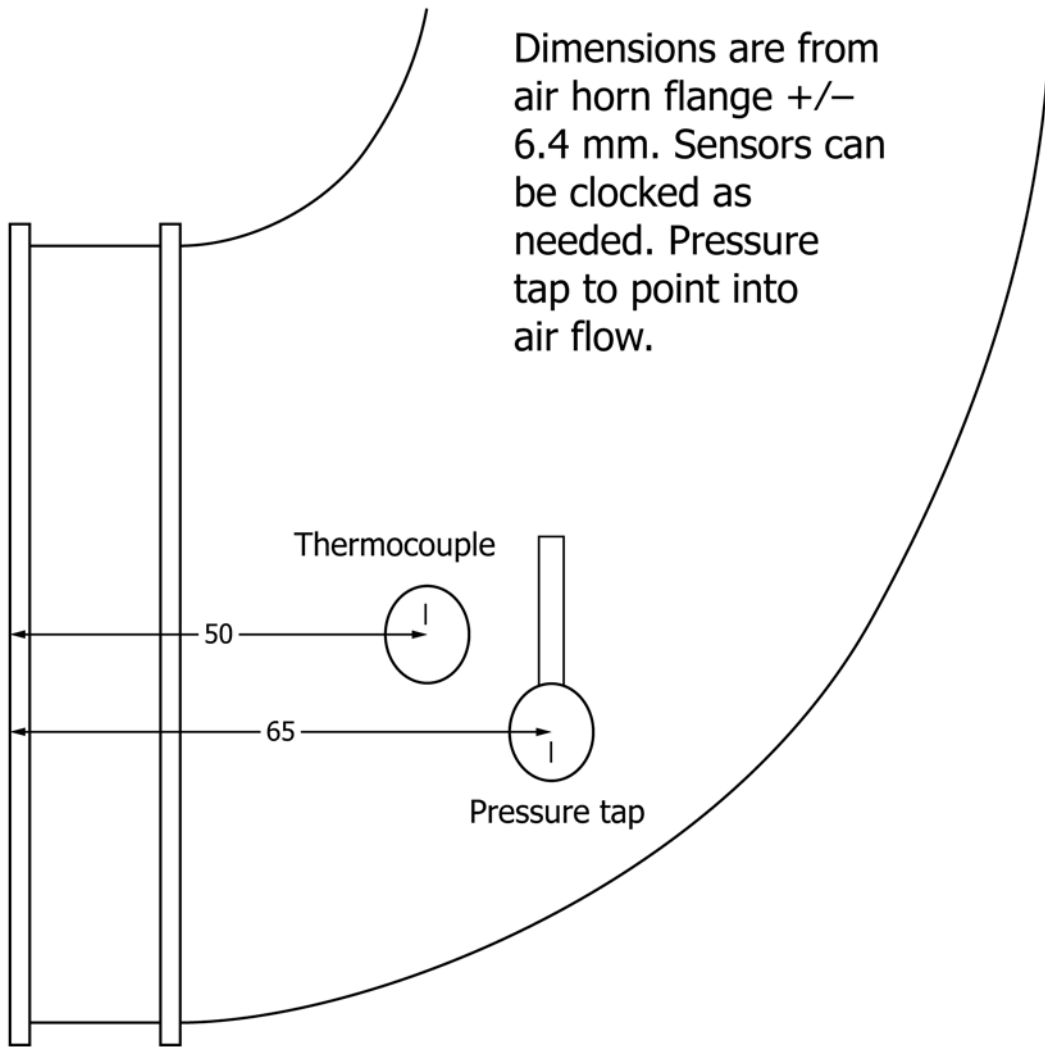

FIG. A5.11 Typical Fuel Delivery System

Dimensions are from air horn flange +/- 6.4 mm. Sensors can be clocked as needed. Pressure tap to point into air flow.



Measurements are in millimeters.

FIG. A5.12 Air Intake Tap Locations

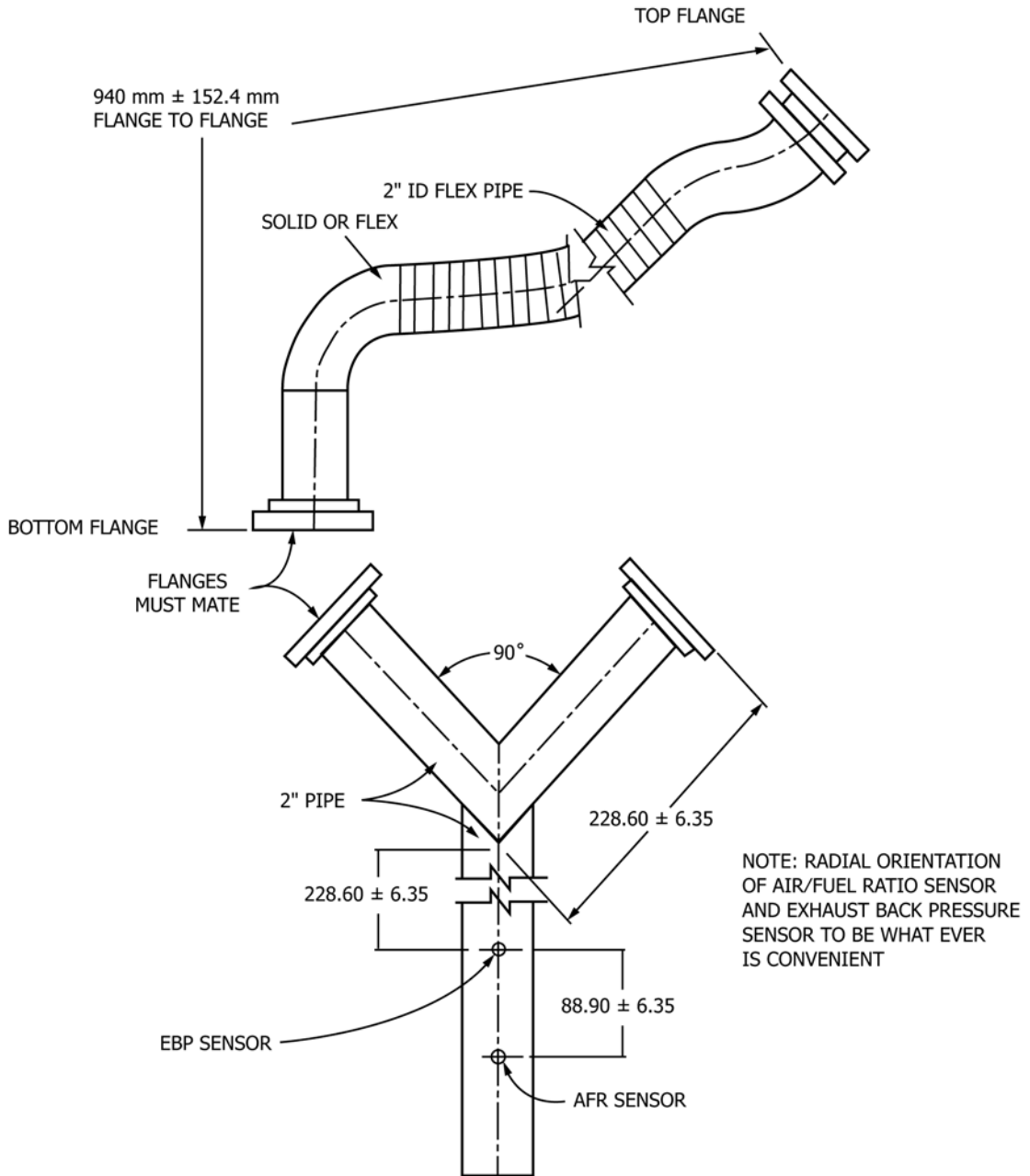

Measurements are in Millimeters with the exception of National Pipe Size

FIG. A5.13 VID Laboratory Exhaust System



FIG. A5.14 Take Down Tube, R.H. Assy.

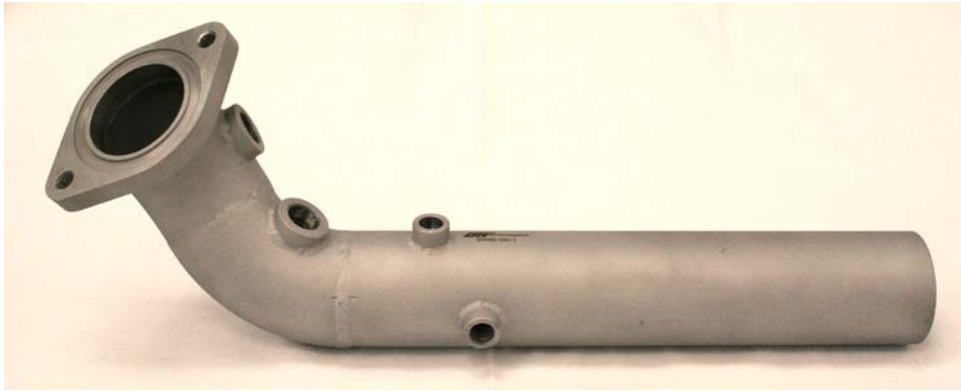
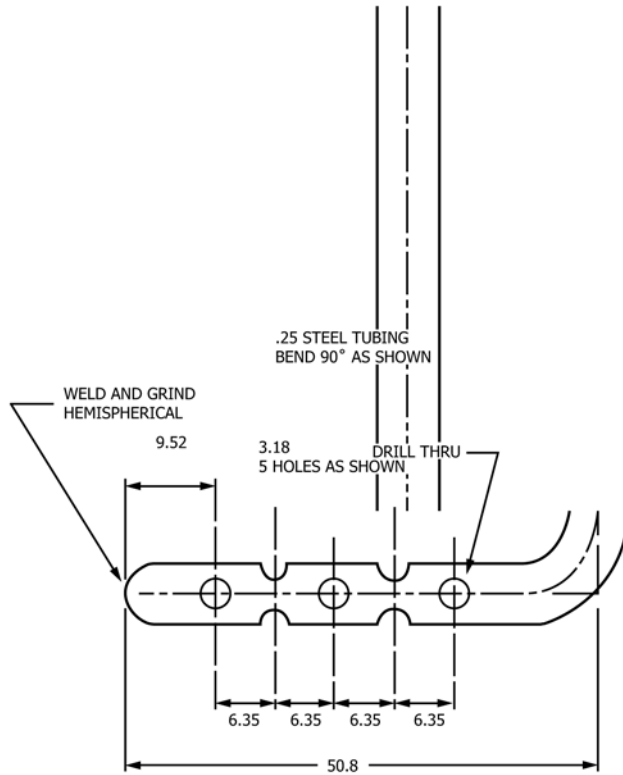
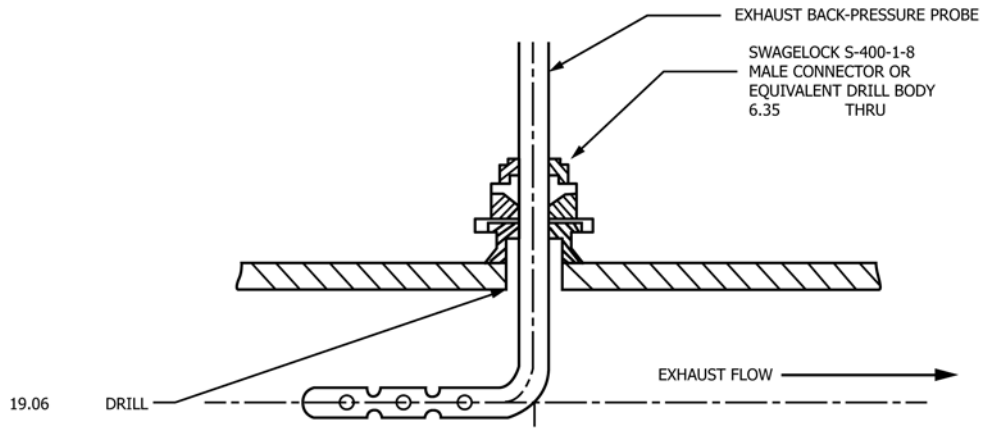

FIG. A5.15 Take Down Tube, L.H. Assy.



PROBE DETAIL



NOTE: BEND EXTERNAL TUBING SEGMENT AFTER ASSY PARALLEL WITH PROBE AXIS AS SHOWN. THIS PERMITS VISUAL ALIGNMENT CHECK DURING OPERATION.

ASSEMBLY DETAIL

Measurements are in millimeters

FIG. A5.16 Exhaust Back Pressure Probe

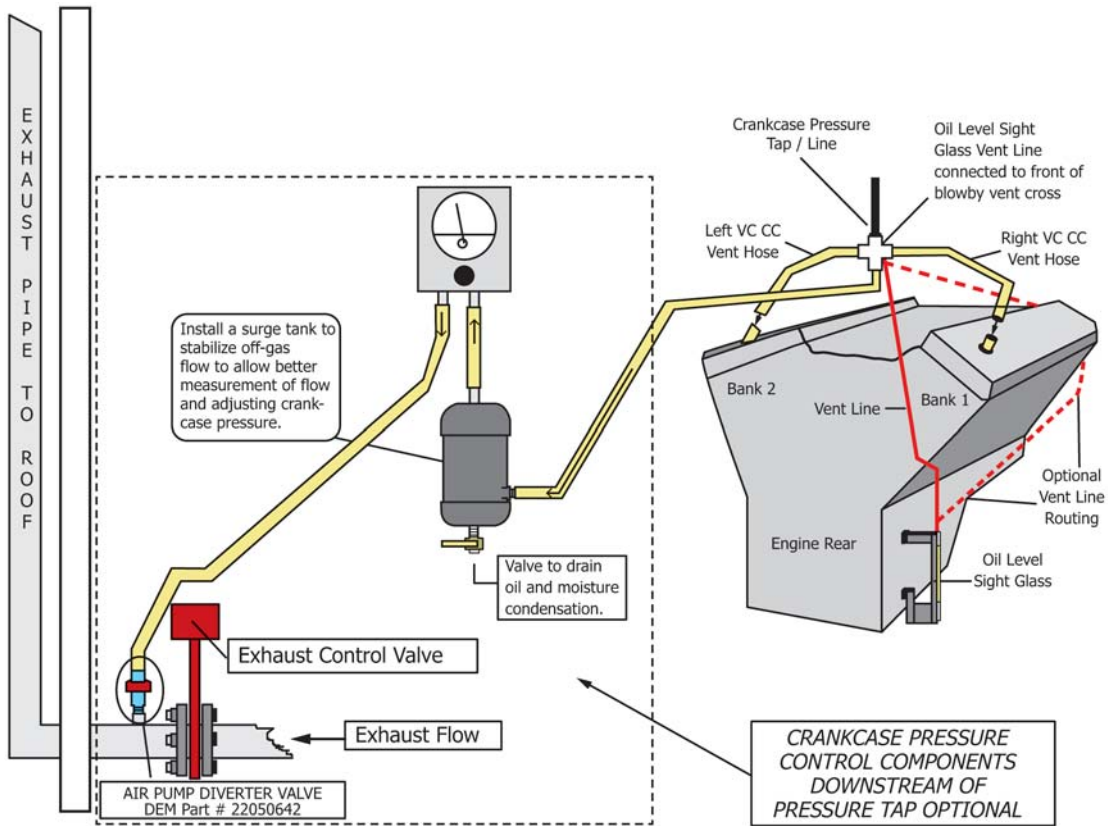

FIG. A5.17 Typical Crankcase Pressure and Blow-by Ventilation System



FIG. A5.18 Flywheel Torque Tool



FIG. A5.19 Crankshaft Holding Tool

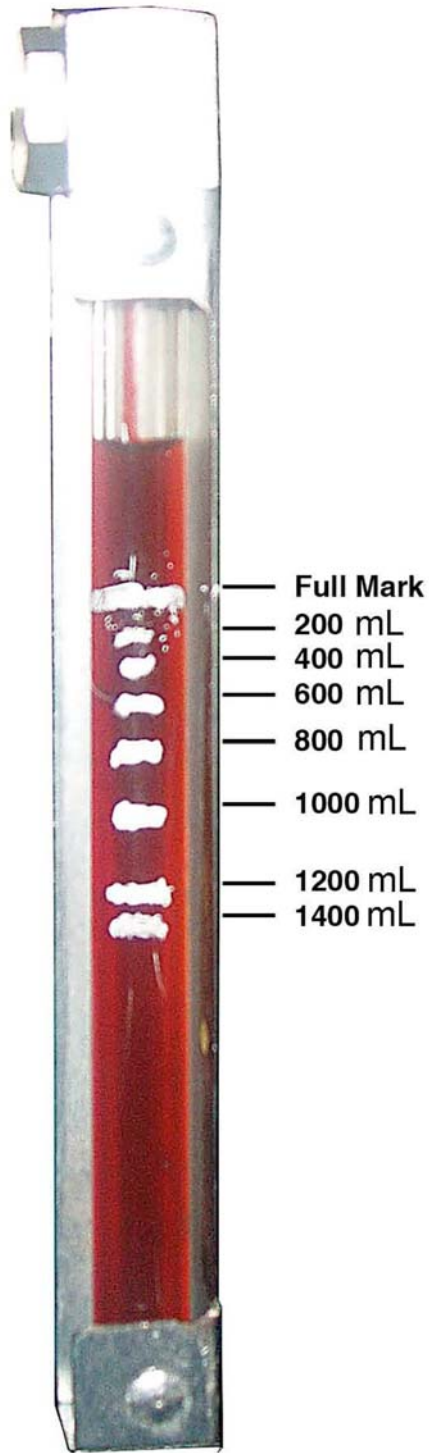

FIG. A5.20 Oil Level Sight Glass

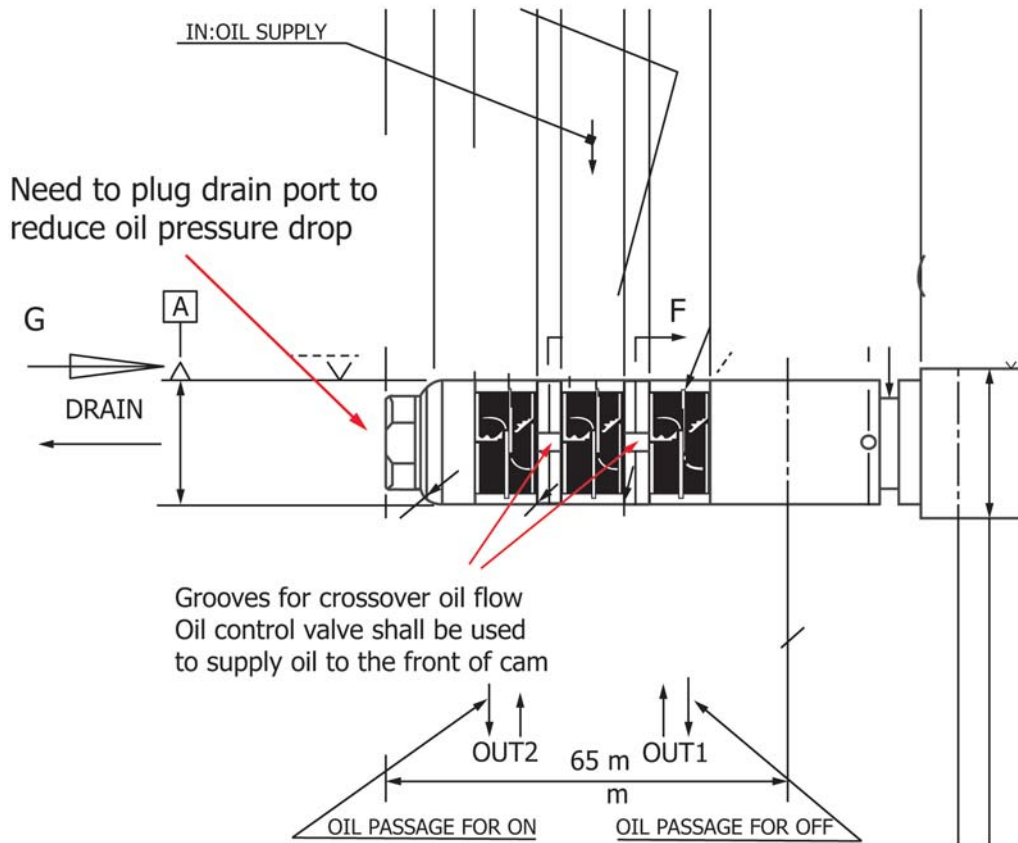

FIG. A5.21 Camshaft Position Actuator Modifications

A6. OIL HEATER CERROBASE REFILL PROCEDURE

A6.1 The cylinder that holds the Cerrobases, Chromalox heater element, and thermocouple is called the cartridge. Take the cartridge out of its insulated case at the engine by backing out six $\frac{3}{8}$ -16 by $\frac{7}{8}$ hex head screws. Hold the cartridge upright in a vise at the work bench.

A6.2 Remove the cable cover and cable connections at the heater element. It is a good idea to make a sketch of the cable connections and shorting bars because this arrangement is not always the same. Remove two $\frac{1}{8}$ NPT pipe plugs at the top of the cartridge so the Cerrobases chamber will be fully vented to atmosphere.

A6.3 Using an acetylene torch, play it on all accessible surfaces of the cartridge until the Cerrobases are completely melted. The Cerrobases shall be liquid. Check with a pre-heated welding rod through one of the $\frac{1}{8}$ NPT holes. Put a wrench on the 3 in. hex flat and try to remove the heater element from the cartridge. Again, be sure the Cerrobases are completely melted before screwing out on the 3 in. hex. Cerrobases melt at 123.8 °C. Don't force the hex. Keep heating the cartridge and pumping the wrench until the heater element can be backed out of the cartridge.

A6.4 After removing the heater element, lay it aside and pour the melted Cerrobases out of the cartridge into a suitable, dry receiver. Keep heat on the cartridge and be sure it is completely empty of Cerrobases and oxide. Clean all surfaces of the cartridge thoroughly by heating and wire brushing.

A6.5 Hold the heater element in a vise across the hex flats. Remove the thermocouple. Play the torch along the heater elements and wire brush, as necessary, to remove oxide.

A6.6 Replace the cartridge in the vise and heat it with a torch. If the Cerrobases are clean and bright, reuse it. In any case, melt 3.85 kg of Cerrobases, enough to fill the cartridge about two-thirds full. A good way to melt the Cerrobases is to hold the ladle in a vise. Heat the ladle and Cerrobases until melted, remembering to put occasional heat on the cartridge to keep Cerrobases in the cartridge liquid. Pour from the ladle carefully to avoid splashing. Avoid thermal shock by keeping all parts coming into contact with Cerrobases well heated.

A6.7 Preheat the heater element and immerse it in the liquid Cerrobases. Pull up on the 3 in. hex to secure the assembly. Screw the heater funnel into one of the 1/8 NPT holes. The heater funnel is made up of a heavy wall funnel welded to a 76.2 mm long, 1/8 in. pipe nipple.

NOTE A6.1—Do not over-torque the 3 in. hex because differential contraction can lock the hex.

A6.8 Keep playing the torch on the cartridge while working and when the heater funnel has been screwed in place, heat it also. Finish filling the cartridge with Cerrobases. Look through the open 1/8 NPT hole to see the Cerrobases liquid level and pour Cerrobases through the funnel until the liquid level is within 57 to 60 mm of the top of the plug. As shown on TD-428, this will leave expansion space for the Cerrobases in the cartridge. If the cartridge should be overfilled use the following technique to remove Cerrobases.

A6.8.1 Cool a piece of welding rod in ice water. Wipe the rod completely dry and immerse it in the Cerrobases. Pull it out. Some Cerrobases will have solidified and frozen to the rod.

Slide Cerrobases off the rod and repeat as necessary to get the liquid level to within 6 mm of the plug.

A6.9 Use a new thermocouple. Thread eleven heat insulation beads on the thermocouple. Check the Cerrobases with welding rod to be sure it is liquid. Pre-heat the thermocouple and push it into the Cerrobases through the drilled hole in the center with a diameter of 6 mm. The eleven beads will serve as a gage to determine immersion depth of the thermocouple. Ensure the 6 mm hole is clean. In the final assembly clearance between this hole and the thermocouple will be the only vent between the Cerrobases and atmosphere. Tie the thermocouple down, otherwise, the thermocouple will float out of the liquid Cerrobases.

A6.10 Let the cartridge cool to room temperature. Remove the heater funnel and install two 1/8 NPT pipe plugs. Connect the cable and shorting bars in their original arrangement. Replace the thermocouple connector and cable cover. Reinstall the cartridge in its insulated case at the engine.

A7. ENGINE PART NUMBER LISTING

A7.1 [Table A7.1](#) lists other specified engine parts.

A7.2 [Table A7.2](#) is the Sequence VID Parts List.

TABLE A7.1 Other Specified Engine Parts

Part Name	Part No.
Mass Air Meter	OHT6D-040-1
Throttle Body	OHT6D-041-1
Dual Throttle Body	OHT6D-050-1
Fuel Injector	OHT6D-042-1
Spark Plug	OHT6D-043-1
Crankshaft Sensor	OHT6D-044-1
Camshaft Sensor	OHT6D-045-1
Knock Sensor	OHT6D-046-1
Pre-Cat Sensor	OHT6D-047-1
Coolant Sensor	OHT6D-048-1
Exhaust Shield (L.H.)	GM12617267
Exhaust Shield (R.H.)	GM12580706
Fuel Rail	GM12572886
Engine Air Cleaner Assembly	See description in standard text
Air Cleaner Element	GM 25798271
Engine Wiring Harness	OHT6D-011-2
Engine Control Module	OHT6D-012-4 (Revision 3)
Exhaust Manifold (R.H.)	GM12571101
Exhaust Manifold (L.H.)	GM12571102
Exhaust Adapter, (R.H.)	OHT6D-010-1
Exhaust Adapter, (L.H.)	OHT6D-009-1
Engine Flywheel	OHT6D-020-X (Lab specific)
Engine Mount Front	OHT3H-026-1
Engine Mount Rear	OHT3H-025-1
Engine Mount Isolators	Labs discretion
Gear, Camshaft, Exhaust, Non-Phased	OHT6D-016-1
Gear, Camshaft, Intake, Non-Phased	OHT6D-017-1
Orifice, Coolant, Internal	OHT6D-025-1

TABLE A7.2 Sequence VID Parts List (June 02, 2009)

OHT Part Number	Description
OHT6D-100-S1 Kit Includes the following items:	Seq. VID Initial Stand Setup Kit
OHT3H-002-1	BLOCK, FLYWHEEL TORQUE
OHT3H-003-1	TOOL, BALANCER TORQUE
OHT3H-025-1	MOUNT, REAR
OHT3H-026-1	MOUNT, FRONT
OHT6D-009-1	TUBE, TAKE DOWN ASSY, RIGHT, SEQ. VID
OHT6D-010-1	TUBE, TAKE DOWN ASSY, LEFT, SEQ. VID
OHT6D-020-X	FLYWHEEL, UNIVERSAL IIIH/VID
6D020-0X	ADAPTER, FLYWHEEL (LAB SPECIFIC: STANDARD/ SWRI/ IMPERIAL/ IAR)
6D011-05	EST, IGNITION HARNESS SECTION, VID E77
6D011-06	CONNECTOR, ECT SENSOR, VID E77 ENGINE HARNESS SEGMENT
6D020-03	BOLTS, FLYWHEEL, VID (PKG. of 8 EACH)
OHT6D-001-1	PAN, OIL, SEQ. VID (w/ Gems Sensor and Displacement Block)
OHT6D-003-1	PLATE, ADAPTER, OIL FILTER
OHT6D-004-1	PLATE, BLOCK-OFF, THERMOSTAT
OHT6D-005-1	PLATE, WATER PUMP
OHT6D-013-1	PCV VALVE, DUMMY
OHT6D-011-2	HARNESS, ENGINE, FOR E77 CONTROLLER
OHT6D-012-4	E77 ECU, HFV6 PFI, LY7, REV. 3
OHT3H-011-2	THROTTLE CONTROL, ENGINE DYNO
OHT6D-040-1	METER, MASS AIR FLOW (HFM), SEQ. VID
OHT6D-042-1	INJECTOR FUEL, SEQ. VID
OHT6D-043-1	PLUG, SPARK, SEQ. VID.
OHT6D-044-1	SENSOR, CRANKSHAFT POSITION, SEQ. VID
OHT6D-045-1	SENSOR, CAMSHAFT POSITION, SEQ. VID
OHT6D-046-1	SENSOR, KNOCK, SEQ. VID
OHT6D-047-1	SENSOR, PRE-CAT O2, SEQ. VID
OHT6D-048-1	SENSOR, COOLANT TEMP, SEQ. VID
OHT6D-050-1	THROTTLE BODY, DUAL
OHT6D-099-1	2008, LY7, HFV6 ENGINE, SEQ. VID (not available from CPD)
OHT6D-099-2	2009, LY7, HFV6 ENGINE, SEQ. VID (not available from CPD)
OHT6D-099-3	LY7, HFV6 ENGINE, TEST PISTON & RING ASSEMBLIES INSTALLED @ OEM, (INCLUDES FIXED GEARS FOR INSTALLATION), SEQ. VID

A8. SAFETY PRECAUTIONS

A8.1 *General Information:*

A8.1.1 The operating of engine tests can expose personnel and facilities to a number of safety hazards. It is recommended that only personnel who are thoroughly trained and experienced in engine testing should undertake the design, installation, and operation of engine test stands.

A8.1.2 Each laboratory conducting engine tests should have their test installation inspected and approved by their Safety Department. Personnel working on the engines should be provided with the proper tools, be alert to common sense safety practices, and avoid contact with moving or hot engine parts, or both. Guards should be installed around all external moving or hot parts. When engines are operating at high speeds, heavy duty guards are required and personnel should be cautioned against working alongside the engine and coupling shaft. Barrier protection should be provided for personnel. All fuel lines, oil lines, and electrical wiring should be properly routed, guarded, and kept in good order. Scraped knuckles, minor burns, and cuts are common if proper safety precautions are not taken. Safety masks or glasses should always be worn by personnel working on the engines and no loose or flowing clothing shall be worn near running engines.

A8.1.3 The external parts of the engine and the floor area around the engines should be kept clean and free of oil and fuel spills. In addition, the working areas should be free of all tripping hazards. In case of injury, no matter how slight, first aid attention should be applied at once and the incident reported. Personnel should be alert for leaking fuel or exhaust gas. Leaking fuel represents a fire hazard and exhaust gas fumes are noxious. Containers of oil or fuel cannot be permitted to accumulate in the testing area.

A8.1.4 The test installation should be equipped with a fuel shut-off valve which is designed to automatically cut off the fuel supply to the engine when the engine is not running. A remote station for cutting off fuel from the test stand is recommended. Suitable interlocks should be provided so that the engine is automatically shut down when any of the following events occur: dynamometer loses field current, engine over speeds, engine oil pressure is lost, exhaust system fails, room ventilation fails, or the fire protection system activates. Consider an excessive Vibration pick-up interlocks if equipment operates unattended. Fixed fire protection equipment should be provided.

A8.1.5 ASTM Sequence Tests use chemicals to clean engines between tests. Some of these chemicals require that personnel wear face masks, dust breathers, and gloves as exothermic reactions are possible. Emergency showers and face rinse facilities should be provided when handling such materials.

A8.2 *Physical and Chemical Hazards List:*

A8.2.1 *Physical Hazards:*

A8.2.1.1 Hot engine parts, exhaust pipe.

A8.2.1.2 Rotating engine/test stand parts (belts, pulleys, shafts).

A8.2.1.3 Electrical shock.

A8.2.1.4 Noise.

A8.2.2 *Chemical and Materials Hazards:*

A8.2.2.1 *Gasoline—(Unleaded):*

(1) Extremely flammable. Vapors harmful if inhaled. Vapors may cause flash fire.

(2) Keep away from heat, sparks, and open flames.

(3) Keep containers closed; use positive shut off valves on fuel lines.

(4) Use with adequate ventilation.

(5) Avoid buildup of vapors and eliminate all sources of ignition, especially non-explosion proof electrical apparatus and heaters.

(6) Avoid prolonged breathing of vapor.

(7) Avoid prolonged or repeated skin contact.

A8.2.2.2 *Organic Solvent (Penmul L460):*

(1) Before opening the container, relieve pressure. Keep the container tightly closed when not in use.

(2) Store at moderate temperatures and keep away from heat, sparks, open flame, and strong oxidizing agents.

(3) Use dry chemical, foam or CO₂ as extinguishing media.

(4) Use safety glasses and impervious gloves when handling.

(5) Use respiratory hydrocarbon vapor canister in enclosed areas.

(6) Use only if adequate ventilation is available.

(7) Avoid contact with eyes, skin, and clothing.

A8.2.2.3 *Degreasing Solvent:*

(1) Combustible vapor harmful if inhaled.

(2) Keep away from heat, sparks, and open flame.

(3) Use with adequate ventilation.

(4) Avoid breathing vapor or spray mist.

(5) Use water spray, dry chemical, foam, or CO₂ as extinguishing media.

(6) Avoid prolonged or repeated contact with skin.

A8.2.2.4 *Cooling System Cleanser:*

(1) Store at moderate temperatures. Keep container closed until used.

(2) Use water spray, dry chemical, foam, or CO₂ as extinguishing media.

(3) Use safety glasses and impervious gloves when handling.

(4) Use respiratory protection in absence of proper environmental control.

(5) Use only if adequate ventilation is available.

(6) Avoid contact with eyes, skin, and clothing.

A8.2.2.5 *Oxalic Acid (Cooling System Cleanser):*

(1) Toxic substance. Avoid contact with eyes, skin, and clothing.

(2) Do not inhale dust.

(3) Keep away from feed or food products.

A8.2.2.6 *New and Used Oil Samples:*

(1) Store at moderate temperatures and keep away from extreme heat, sparks, open flame, and oxidizing agents.

(2) Use dry chemical, foam, or CO₂ as extinguishing media.

(3) Use safety glasses and impervious gloves when handling.

(4) Avoid contact with eyes, skin, and clothing.

A8.2.2.7 Used Oil Samples Only—Since used oils contain compounds that were not originally present in the new oil, stringently follows the Materials Safety Data Sheet's guidelines for all components present.

NOTE A8.1—In addition to other precautions, note that continuous contact with used automotive engine oils has caused skin cancer in laboratory mice.

A9. SEQUENCE VID TEST REPORT FORMS AND DATA DICTIONARY

A9.1 The actual report forms and data dictionary shall be downloaded separately from the ASTM TMC Web Page at <http://www.astmtmc.cmu.edu/>, or they can be obtained in hardcopy format from the TMC.

A10. STATISTICAL EQUATIONS FOR MEAN AND STANDARD DEVIATION

A10.1 *Equations:*

$$\text{mean} = \frac{1}{n} \sum_{i=1}^n [Y_i(\text{standard}) - Z_i(\text{reading})] \quad (\text{A10.1})$$

$$\text{standard deviation} = \sqrt{\frac{\sum_{i=1}^n [(Y_i - Z_i) - \text{mean}]^2}{df}} \quad (\text{A10.2})$$

where:

N = total number of data pairs, and
 df = degrees of freedom = $n - 1$.

A11. DETERMINING THE OIL SUMP FULL LEVEL

A11.1 *Determining the Oil Sump Full Level:*

A11.1.1 Verify engine orientation on the test stand:

A11.1.1.1 Side to side engine mounting ($0.0 \pm 0.5^\circ$),

A11.1.1.2 Engine flywheel friction faceplate ($3.0 \pm 0.5^\circ$), and

A11.1.1.3 Driveline angle not less than 1.0° or greater than 2.0° in the vertical.

A11.1.2 Charge the engine with 5.4 L of BL oil.

A11.1.3 Start the engine and bring to stage Flush 1500 r/min, 70 N·m, coolant in 109°C , and oil temperature 115°C . Stabilize for 15 min.

A11.1.4 Shut engine down.

A11.1.5 Remove the oil from the engine using the scavenge pump.

A11.1.6 Disconnect all lines from the oil pan and allow to gravity drain.

A11.1.7 Connect the complete external oil system, including the engine oil filter, in series and in the same direction as

normal oil flow. Use extra lines if needed to connect the engine oil filter into the complete system.

A11.1.8 Set the 3-way control valve (TCV-144) so that 100 % of the flow is through the heat exchanger (HX-60).

A11.1.9 Connect and purge air through the external oil flush system (step 7) using a minimum of 138 kPa. (**Warning**—Lock recirculation oil pump shaft to avoid damage.)

A11.1.10 Flow air through the external oil flush system (step 7) until most of the oil has been purged from the system.

A11.1.11 Cycle the 3-way control valve (TCV-144) a few times to ensure oil is purged from the bypass section of the heat exchanger (HX-6).

A11.1.12 Disconnect air supply.

A11.1.13 Connect degreasing solvent flush system to the external oil flush system (step 7).

A11.1.14 Circulate degreasing solvent (minimum of 8 L) through the external oil flush system (step 7) for a minimum of 30 min.

A11.1.15 Cycle the 3-way control valve (TCV-144) a few times to ensure oil is purged from the bypass section of the heat exchanger (HX-6).

A11.1.16 Disconnect the degreasing solvent flush system and drain the solvent from the external oil flush system.

A11.1.17 Connect and purge air through the external oil flush system (step 7) for minimum of 1 h using a minimum of 138 kPa. Set the 3-way control valve (TCV-144) so that 100 % of the flow is through the heat exchanger (HX-6) for most of the hour. Cycle the 3-way control valve (TCV-144) a few times during the hour to ensure the degreasing solvent has been flushed from the bypass section of the heat exchanger (HX-6).

A11.1.18 Individually check, and purge with air if necessary, the heat exchanger (HX-6), oil heater, circulating oil pump, and oil filters to ensure all the degreasing solvent has been removed.

A11.1.19 Measure 5.4 L of BL oil and pour into engine.

A11.1.20 Start engine and ramp to Flush conditions.

A11.1.21 Once stabilized at the above conditions; mark the level on the sight glass (Fig. A5.20) and consider this as the Oil Sump Full Level.

A11.2 Oil Pan Sight Glass Calibration:

A11.2.1 With the proper full mark established on the oil pan sight glass tube (see Fig. A5.20) and the engine running at flush

conditions drain 200 mL of oil from the engine at the outlet (top) of the oil heater. Allow a few minutes for system to stabilize then mark sight glass (–200 mL).

A11.2.2 Repeat above in increments of 200 mL until a total of 1400 mL has been removed from engine. Mark the sight glass in increments of 200 mL.

A11.2.3 Return the 1400 mL of oil with engine running at flush conditions, allow the system to stabilize a few minutes. The oil level should now be at the original full mark on the sight glass. Repeat the calibration procedure if the level does not return to the original sight glass full mark.

A11.2.4 Determine the oil level in the oil pan using a level made of Tygon tubing filled with water. Use the full mark on the oil sight glass as the reference point.

A11.2.5 Mark the oil level on the outside of the oil pan with a paint marker.

A11.2.6 The paint mark on the oil pan shall be approximately located above the oil pump inlet fitting and lined up with the center of the oil pan tab. This tab is approximately 100 mm from the top sight glass fitting and toward the front of the engine.

A11.2.7 Measure the distance from the bottom surface of the oil pan tab to the paint mark. This is the engine oil full level measurement. This measurement shall be 77 mm ± 5 mm.

A12. FUEL INJECTOR EVALUATION

A12.1 *Fuel Injector Test Rig*—A suitable device capable of accurate, repeatable flow measurement of port fuel injectors is required. This device shall be capable of performing necessary port fuel injector evaluations as outlined in A12.2. Since no suitable commercially available apparatus has been identified, design of the test rig is up to the laboratory. Flow test the injectors using degreasing solvent as the test fluid.

A12.2 *Fuel Injectors*—Prior to engine installation, evaluate all injectors (new and used) for spray pattern and flow-rate using the test rig in A12.1. Injectors may be cleaned and reused if the criteria outlined in this procedure are satisfied.

A12.2.1 Perform a visual inspection of each injector to ensure that each injector has been cleaned of all oily deposits.

A12.2.2 Check the injector “O” ring for cracking or tearing and replace as required.

A12.2.3 Flush new injectors to remove any assembly residue before flow testing for 30 s.

A12.2.4 Place the injector(s) in the test rig and turn the test fluid on. Verify the flow of test fluid through the injector(s). Maintain the test fluid pressure supplied to the injector(s) during the entire test at 290 kPa ± 3.4 kPa. The maintenance of this pressure is critical as a small change in pressure will have a dramatic effect on the flow rate and spray pattern. Once pressure is set, zero the volume measuring device.

A12.2.5 Flow test each injector for a 60 s period. While the injector is flowing, make a visual observation of the spray pattern quality. The spray pattern shall be typical for the make and model of the injector.

A12.2.6 The set of injectors for an engine shall have a flow rate within of each other of 5 mL. Discard any injector that does not flow within this range.

A12.2.7 At completion of the 60 s period, close the injector and maintain the test fluid pressure for a minimum of 30 s. Discard any injector that leaks or drips.

A13. PRE-TEST MAINTENANCE CHECKLIST

A13.1 See [Table A13.1](#).

TABLE A13.1 Pre-test Maintenance Checklist

Required Maintenance	Schedule
Replace spark plugs	A
Service racor filters	B
Verify injector flows	C
Clean/recondition throttle body	A
Clean coolant heat exchanger	A
Clean / flush oil heat exchanger	C
Replace fuel filters	A
Inspect / service driveline	B
Rotate dyno trunion bearings	A
Clean / replace EBP probe	A

^A As required by normal laboratory practice.

^B Prior to each test.

^C With the installation of new engine.

A14. BLOW-BY VENTILATION SYSTEM REQUIREMENTS

A14.1 NPT cross fitting, $\frac{3}{8}$ in.

A14.2 NPT pipe nipple (three), $\frac{3}{8}$ in., used to connect the 12.7 mm ID or 15.8 mm ID hose to the $\frac{3}{8}$ in. NPT cross fitting.

A14.3 OHT6D-013-1 Dummy PCV fitting installed in the right side of the rocker cover.

A14.4 Left rocker cover shall use the original 45° fitting supplied with the engine.

A14.5 Right rocker cover shall have 304.8 mm \pm 127 mm of (ID) 12.7 mm or (ID) 15.8 mm hose to the $\frac{3}{8}$ in. NPT cross fitting.

A14.6 Left rocker cover shall have 304.8 mm \pm 127 mm of (ID) 12.7 mm or (ID) 15.8 mm hose to the required cross fitting.

A14.7 Monitor crankcase pressure at the top of the $\frac{3}{8}$ in. NPT cross fitting.

A15. CALCULATION OF TEST RESULTS

A15.1 Calculate each BSFC measurement ([11.6.5](#)) taken at 5 min using the average speed, torque, and fuel flow acquired during the stabilized BSFC measurement cycle as follows:

$$\text{BSFC} = \frac{(\text{average fuel flow, kg/h})(9549.3)}{(\text{average speed, r/min})(\text{average torque, N}\cdot\text{m})} \quad (\text{A15.1})$$

A15.1.1 Ensure average speed is acquired to a minimum of one whole number (zero decimal places).

A15.1.2 Ensure average torque is acquired to a minimum of two decimal places.

A15.1.3 Ensure fuel flow is acquired to a minimum of three decimal places.

A15.2 For Stage 1, segment 1 through 6, round and record the 5 min BSFC measurements to 4 decimal places using ASTM rounding.

A15.3 Average the BSFC measurements of the six steps to 5 decimal places using ASTM rounding. Units for BSFC are kg/kWh.

A15.4 Multiply the average by the nominal power, stage length, and weight factor (below) for Stage 1 and record the answer to 6 decimal places. The unit for this number is kilograms of fuel consumed.

Test Stage	Nominal Speed (r/min)	Nominal Power (kW)	Stage Length (h)	Weight Factor
1	2000	21.99	0.5	0.300
2	2000	21.99	0.5	0.032
3	1500	16.49	0.5	0.310
4	695	1.46	0.5	0.174
5	695	1.46	0.5	0.011
6	695	2.91	0.5	0.172

A15.5 Perform calculation steps A15.1 – A15.4 for the remaining test stages (2 to 6) using the respective nominal power, stage length, and weight factors.

A15.6 Total the mass fuel consumption values for all 6 stages.

A15.7 Complete the total fuel consumed calculation detailed in Steps A15.1 – A15.6 above for the BL Before Test Oil 1, BL Before Test Oil 2, Test Oil Phase I, Test Oil Phase II, and BL After Test Oil.

A15.8 Compute the test oil fuel economy improvement (FEI) as follows:

$$\text{Percent FEI Test Oil Phase I} = \left\{ \left[(\text{BL Before 2} \times 80\%) + (\text{BL After} \times 20\%) - \text{Test Oil} \right] / \left[(\text{BL Before 2} \times 80\%) + (\text{BL After} \times 20\%) \right] \right\} \times 100 \quad (\text{A15.2})$$

$$\text{Percent FEI Test Oil Phase II} = \left\{ \left[(\text{BL Before 2} \times 10\%) + (\text{BL After} \times 90\%) - \text{Test Oil} \right] / \left[(\text{BL Before 2} \times 10\%) + (\text{BL After} \times 90\%) \right] \right\} \times 100 \quad (\text{A15.3})$$

A15.9 Adjust the FEI results for engine hours as follows:

$$\text{Adjusted FEI1} = \text{FEI1} + (0.28897 \times (\text{natural log}(\text{engine hours}) - 7.377)) \quad (\text{A15.4})$$

$$\text{Adjusted FEI2} = \text{FEI2} + (0.27207 \times (\text{natural log}(\text{engine hours}) - 7.377)) \quad (\text{A15.5})$$

A15.10 Adjust the FEI engine hour adjusted result(s) on non-reference oil tests for the stand/engine severity in accordance with Annex A10.

A16. CALCULATION OF UNWEIGHTED BASELINE SHIFT

A16.1 Calculate each BSFC measurement taken at 5 min using the average speed, torque, and fuel flow acquired during the stabilized BSFC measurement cycle as follows:

$$\text{BSFC} = \frac{(\text{average fuel flow, kg/h})(9549.3)}{(\text{average speed, r/min})(\text{average torque, N}\cdot\text{m})} \quad (\text{A16.1})$$

A16.1.1 Ensure average speed is acquired to a minimum of one whole number (zero decimal places).

A16.1.2 Ensure average torque is acquired to a minimum of two decimal places.

A16.1.3 Ensure fuel flow is acquired to a minimum of three decimal places.

A16.2 For Stage 1, segments 1 through 6, round and record the 5 min BSFC measurements to 4 decimal places using ASTM rounding.

A16.3 Average the BSFC measurements of the six steps to 5 decimal places using ASTM rounding. Units for BSFC are kg/kWh.

A16.4 Multiply the average by the shown nominal power and stage length from Table 6 for Stage 1 and record the answer to 6 decimal places. The unit for this number is kg of fuel consumed.

A16.5 Perform calculation steps 1, 2, 3, and 4 for the remaining test stages (2 to 6) using the respective nominal power and stage lengths.

A16.6 Total the mass fuel consumption values for all 6 stages.

A16.7 Complete the total fuel consumed calculation detailed in Steps 1 to 6 above for the BL Before Test Oil 1, BL Before Test Oil 2, and BL After Test Oil.

A16.8 Compute the baseline shift results as follows:

$$\begin{aligned} \text{Percent unweighted Baseline Shift BLB1 to BLB2} \\ = \left\{ \left[\text{Unweighted BLB1} - \text{Unweighted BLB2} \right] / \text{Unweighted BLB1} \right\} \\ \times 100 \quad (\text{A16.2}) \end{aligned}$$

$$\begin{aligned} \text{Percent unweighted Baseline Shift BLB2 to BLA} \\ = \left\{ \left[\text{Unweighted BLB2} - \text{Unweighted BLA} \right] / \text{Unweighted BLB2} \right\} \\ \times 100 \quad (\text{A16.3}) \end{aligned}$$

A17. NON-PHASED CAM GEAR AND POSITION ACTUATOR INSTALLATION PROCEDURE

A17.1 Ensure all four camshafts are positioned with flats parallel to rocker cover sealing surface. Positioning the flats parallel assures that the cam lobes are all on a portion of the base circle and the engine will thereby be a free spin so you can rotate the crankshaft without the pistons hitting the valves (see [Fig. A17.1](#)).

A17.2 Install all four camshaft sprockets, i.e., intakes on the inboard cams and exhausts on the outboard camshafts (see [Fig. A17.2](#)).

A17.3 After installation of left side gears, torque all four fasteners to $58 \text{ N}\cdot\text{m} \pm 7 \text{ N}\cdot\text{m}$, holding camshafts on hex with open end wrench (see [Fig. A17.3](#)).

A17.4 Install left chain assembly with left side idler gear (do not remove grenade pin), aligning white marks on chain with dots on camshaft gears identified as “L” Intake and “L” Exhaust on camshaft gears. Torque left side idler gear to $58 \text{ N}\cdot\text{m} \pm 7 \text{ N}\cdot\text{m}$ (see [Fig. A17.4](#)).

A17.5 Install left side chain guides, left side tensioner and gasket. Torque tensioner and chain guide fasteners to $23 \text{ N}\cdot\text{m} \pm 3 \text{ N}\cdot\text{m}$ (see [Fig. A17.5](#)).

A17.6 Install right side idler gear and torque to $58 \text{ N}\cdot\text{m} \pm 7 \text{ N}\cdot\text{m}$, and verify the left side idler gear still has grenade pin holding chain assembly in proper position (see [Fig. A17.6](#)).

A17.7 Install crankshaft gear and align dot for left side chain alignment (see [Fig. A17.7](#)).

A17.8 Install primary chain assembly over left, right idlers and crankshaft gears with white identification marks aligned with marks on all three gears (see [Fig. A17.8](#)).

A17.9 Install primary chain guides, primary chain tensioner and gasket. Torque tensioner and guide fasteners to $23 \text{ N}\cdot\text{m} \pm 3 \text{ N}\cdot\text{m}$. Torque right side idler gear to $58 \text{ N}\cdot\text{m} \pm 7 \text{ N}\cdot\text{m}$ (see [Fig. A17.9](#)).

A17.10 Remove grenade pin from left side idler and rotate crankshaft to right side alignment marks. Verify the dot on crankshaft gear aligns with the mark on timing chain and boss on oil pump housing (see [Fig. A17.8](#) and [Fig. A17.10](#)).

A17.11 Note hole in right side idler gear as noted by pen and align right side chain over idler with white link positioned at hole in right side idler and white marks positioned on cam gears at “R” Exhaust and “R” Intake (see [Fig. A17.11](#)).

A17.12 Holding chain together, install chain guides and tensioner. Note, the right bank is the hardest chain to keep tension on during the assembly process. Torque tensioner and chain guides to $23 \text{ N}\cdot\text{m} \pm 3 \text{ N}\cdot\text{m}$ (see [Fig. A17.12](#)).

A17.13 Remove grenade pin from right side chain tensioner (see [Fig. A17.13](#)).

A17.14 Check alignment on all four cam gears, primary chain idlers, and crank gear (see [Fig. A17.14](#) and [Fig. A17.15](#)).

A17.15 Rotate crankshaft backward (counter clockwise just past left side alignment and then back to left side alignment and check white marks for proper alignment. Rotate crankshaft clockwise to right side alignment and check marks. Ensure that chain assemblies do not jump on gears.

A17.16 Install 8 mm (0.315 in.) guide pins into the cylinder block positions as shown in [Fig. A17.16](#).

A17.17 Inspect front cover to cylinder block seal. Install existing seal or replace with a new seal if existing seal is damaged or otherwise unusable (see [Fig. A17.17](#)).

A17.18 Place a 3 mm bead of RTV sealant, GM P/N 12378521 on the engine front cover as shown in [Fig. A17.18](#) (1).

A17.19 Place the engine front cover onto the guide pins and slide into position (see [Fig. A17.19](#)).

A17.20 Loosely install the front cover bolts and install the engine front cover sound deadener (see [Fig. A17.20](#)).

A17.21 Tighten the engine front cover bolts in the sequence shown in [Fig. A17.21](#) (1-22). Torque to $20 \text{ N}\cdot\text{m}$. Tighten an additional 60° using the sequence shown (1-22).

A17.22 Install the modified Camshaft Position Actuators as shown in [Fig. A17.22](#). Torque bolts to $10 \text{ N}\cdot\text{m}$.

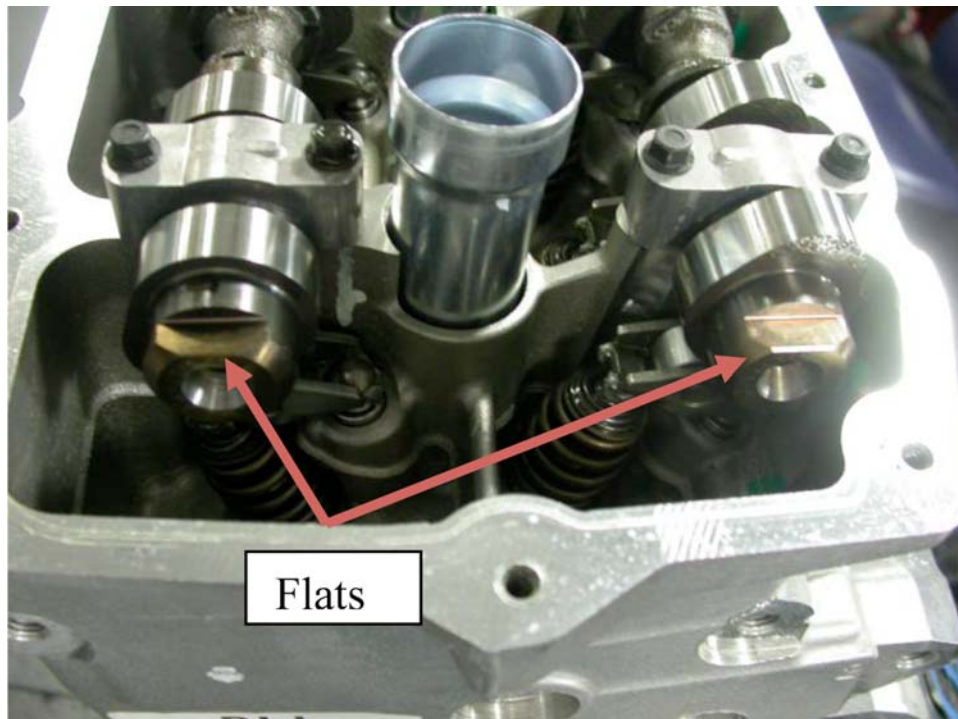

FIG. A17.1 Locating Camshaft "Flats"

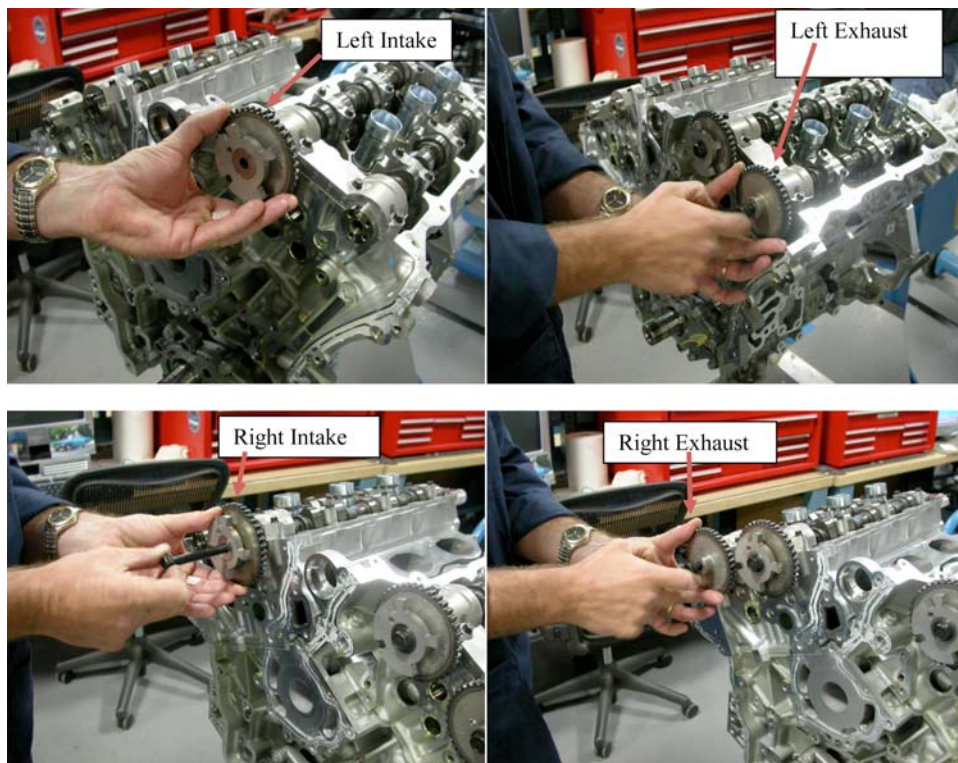

FIG. A17.2 Camshaft Sprocket Installation

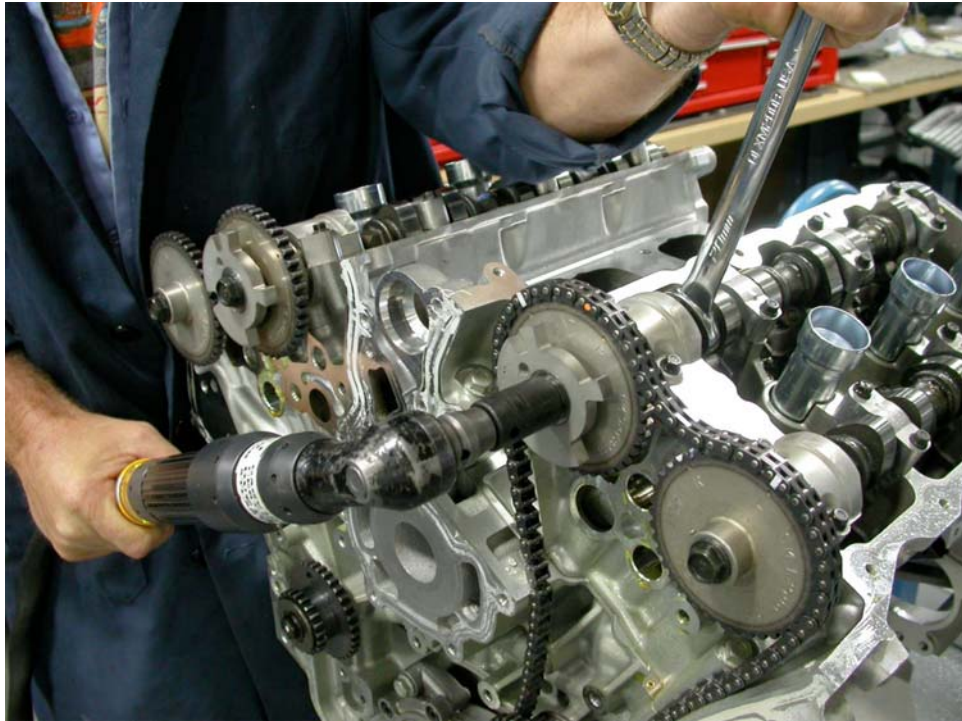

FIG. A17.3 Torquing Camshaft Sprocket Fasteners

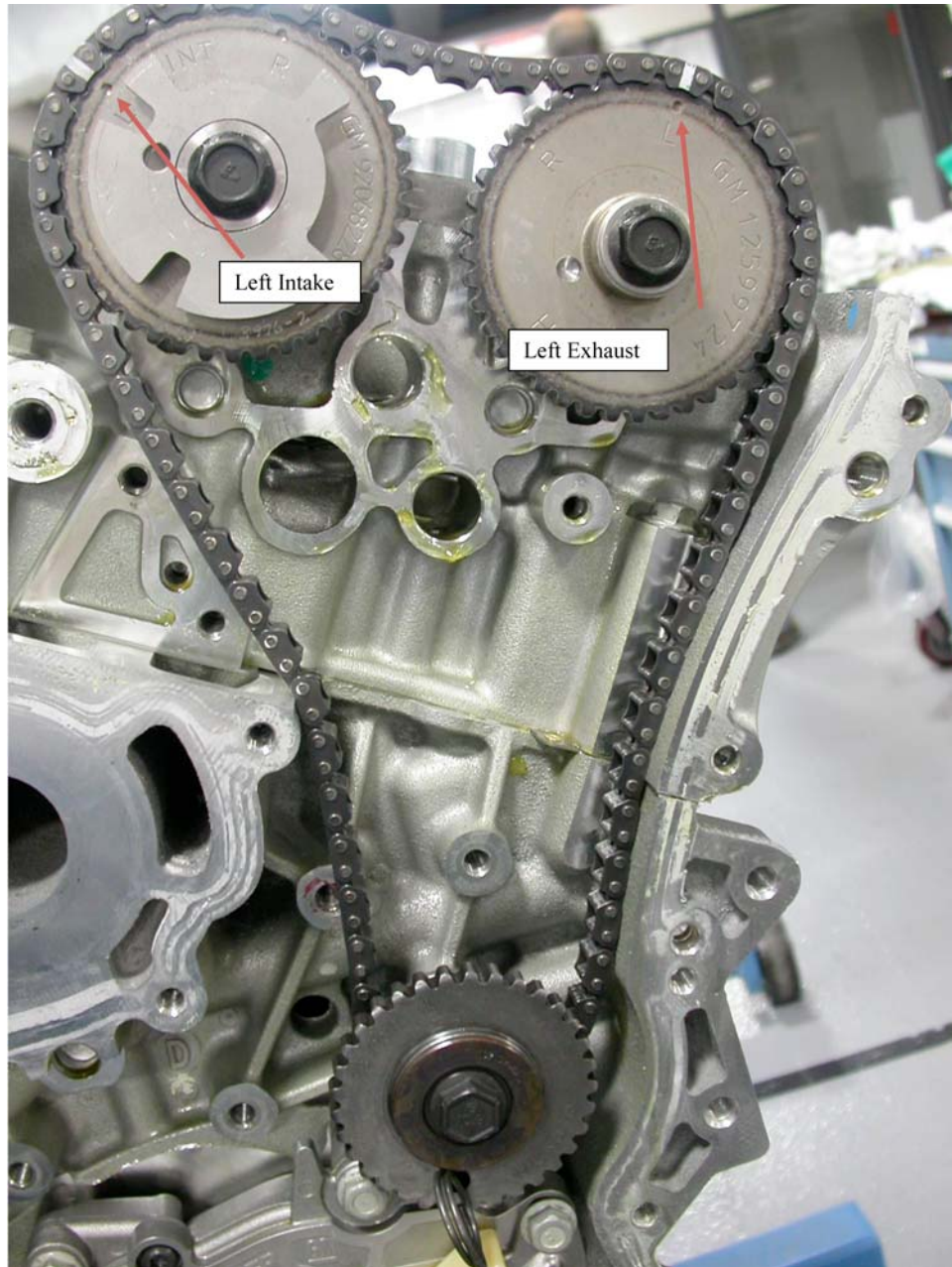

FIG. A17.4 Alignment of Timing Marks, Left Side, with Grenade Pin Installed

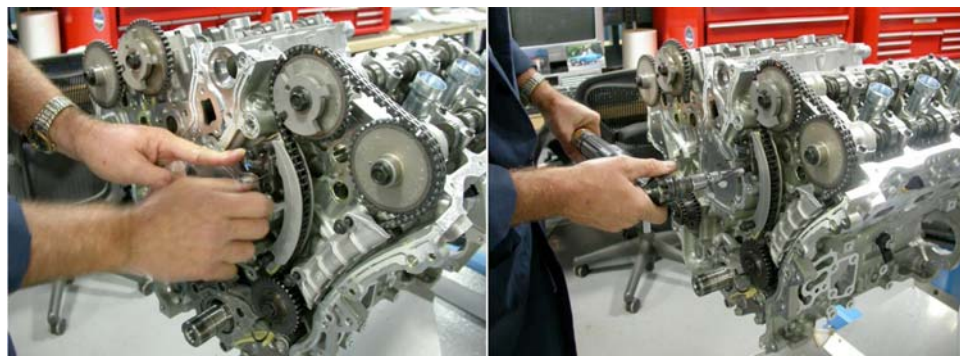
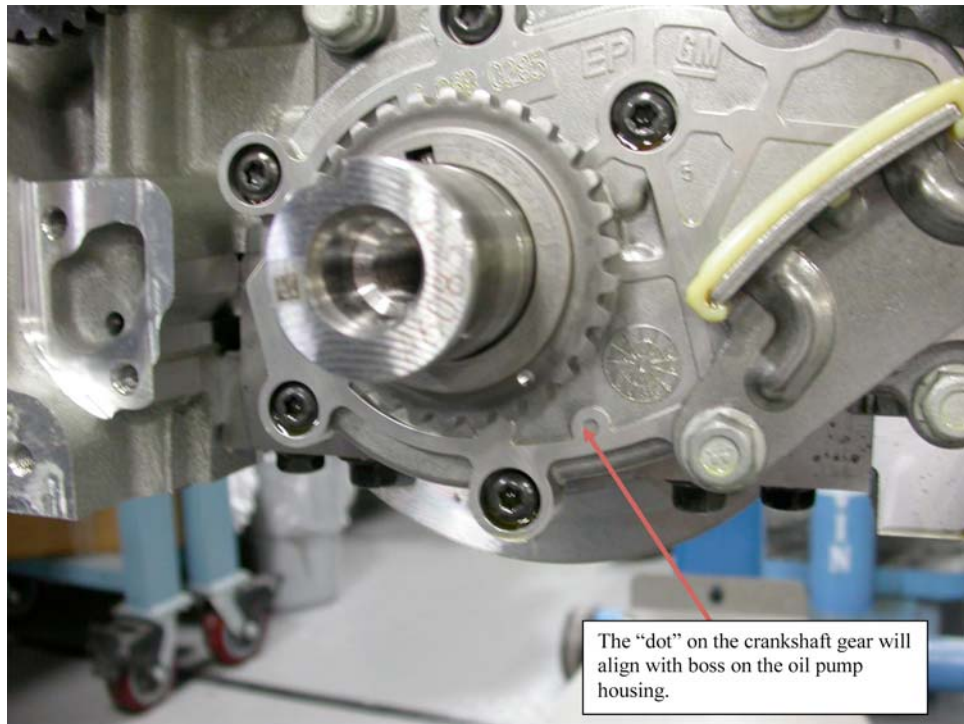

FIG. A17.5 Installation of Chain Guide, Tensioner and Gasket, Left Side



FIG. A17.6 Installation of Right Side Idler Gear



The "dot" on the crankshaft gear will align with boss on the oil pump housing.

FIG. A17.7 View Showing Installation and Alignment Marks

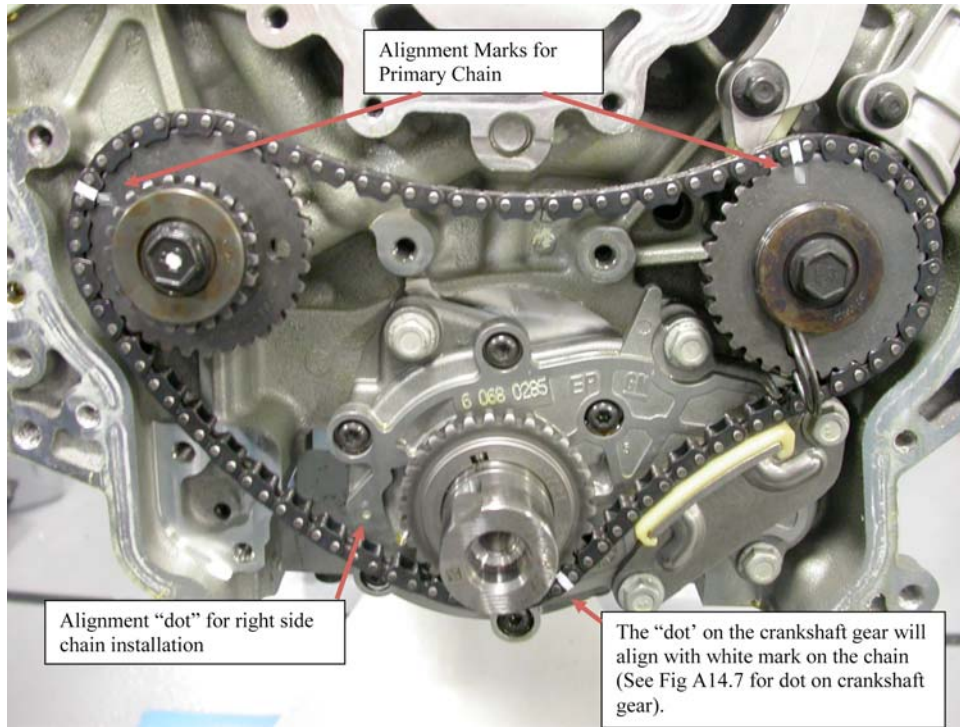

FIG. A17.8 Primary Chain Alignment Marks



FIG. A17.9 View Showing Installation of Primary Chain Tensioner and Guides

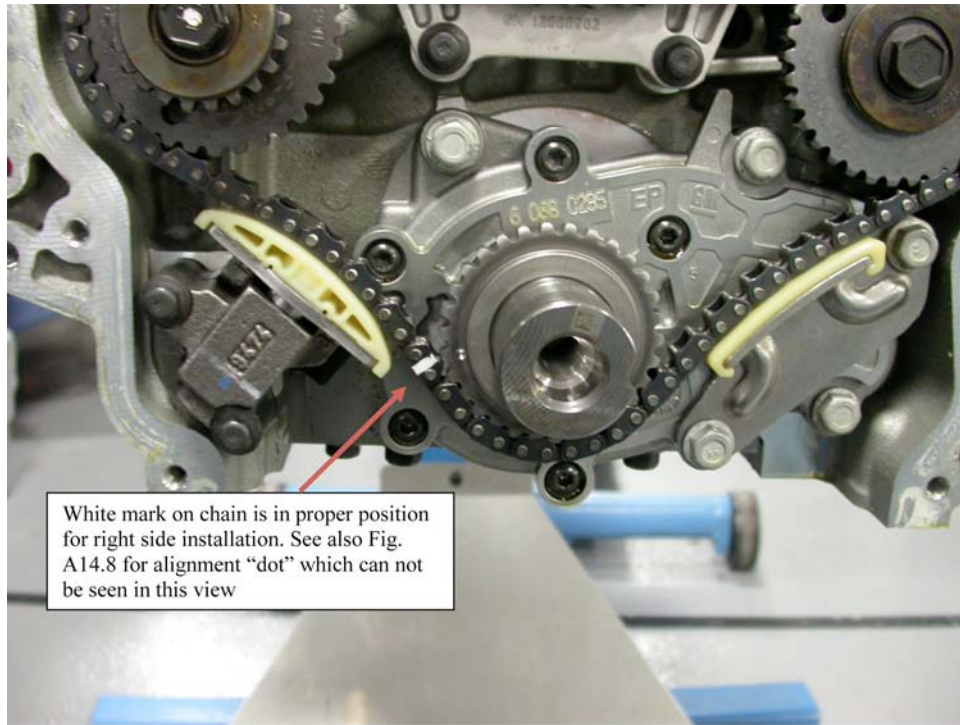

FIG. A17.10 View Showing Timing Proper Alignment

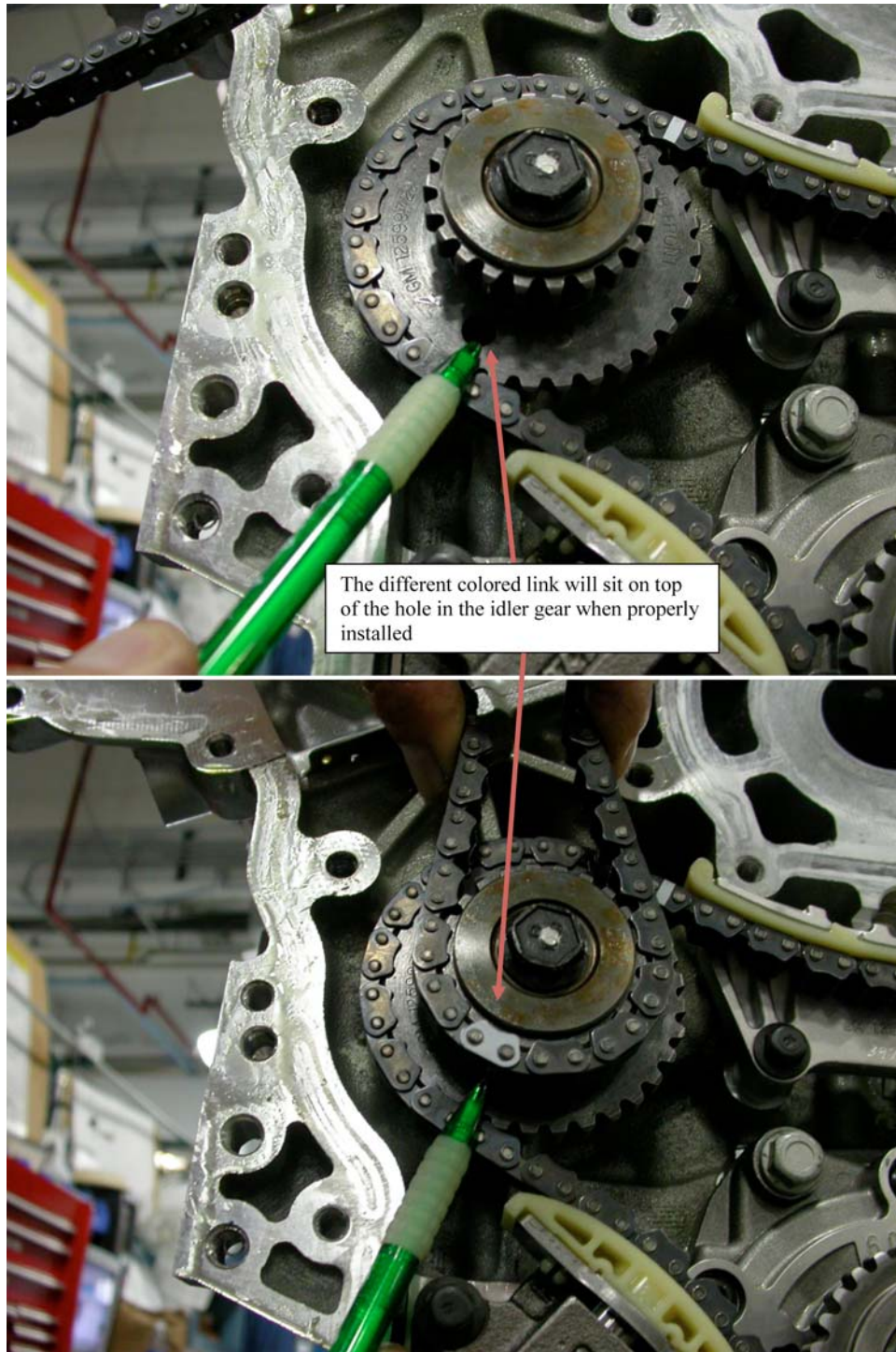

FIG. A17.11 View Showing Proper Gear Alignment for Right Side

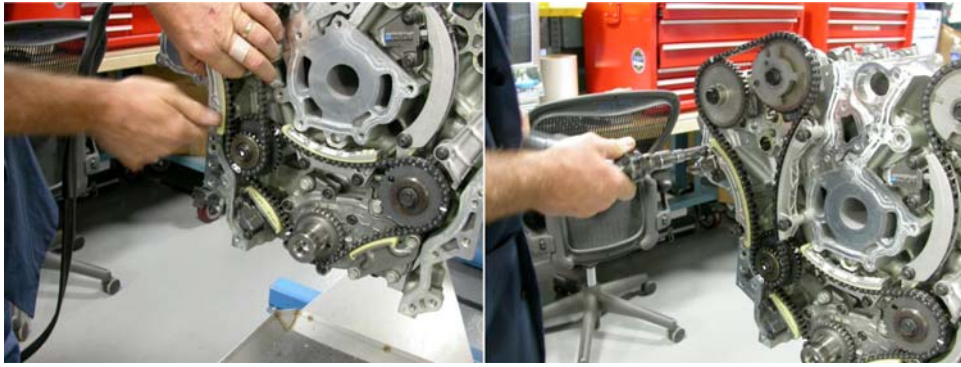

FIG. A17.12 View Showing Chain Guide and Tensioner Installation



FIG. A17.13 View Showing Grenade Pins from Right Side Tensioner Removed

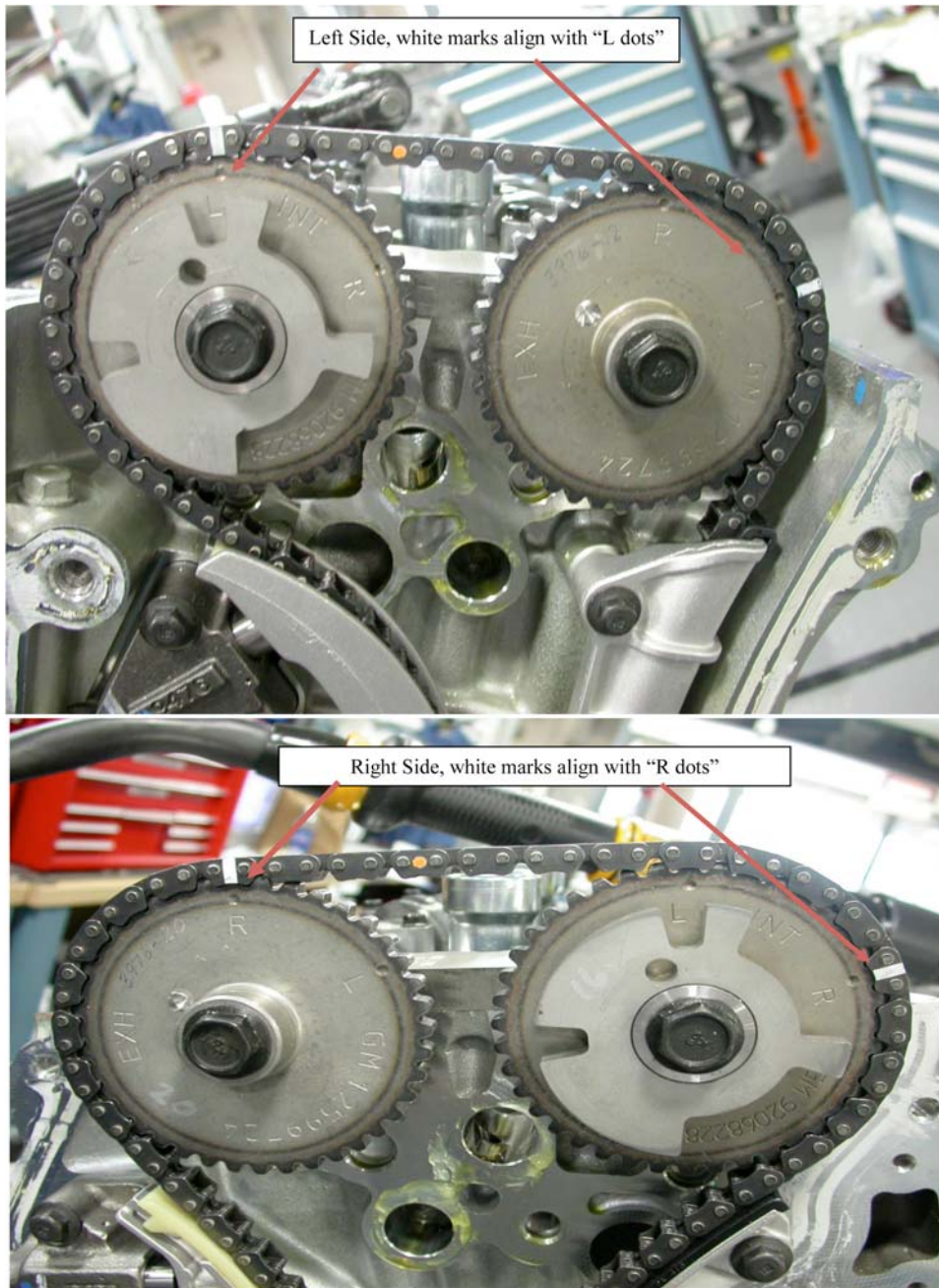

FIG. A17.14 Views Showing Proper Alignment, Left and Right Chains



FIG. A17.15 Right Side Chain and Idler Alignment Marks

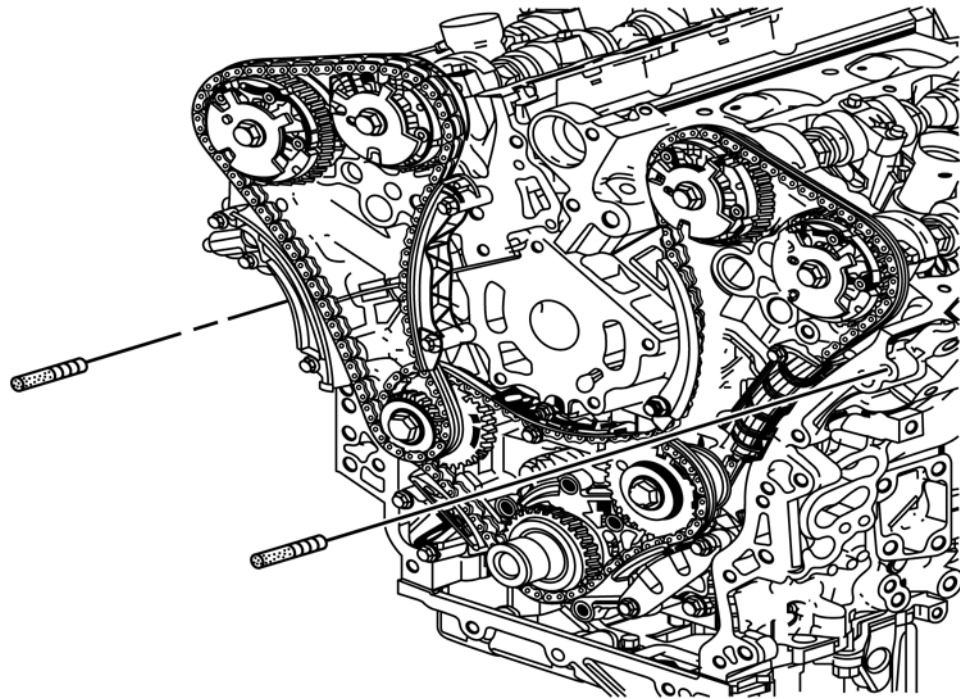

FIG. A17.16 Location of Guide Pins

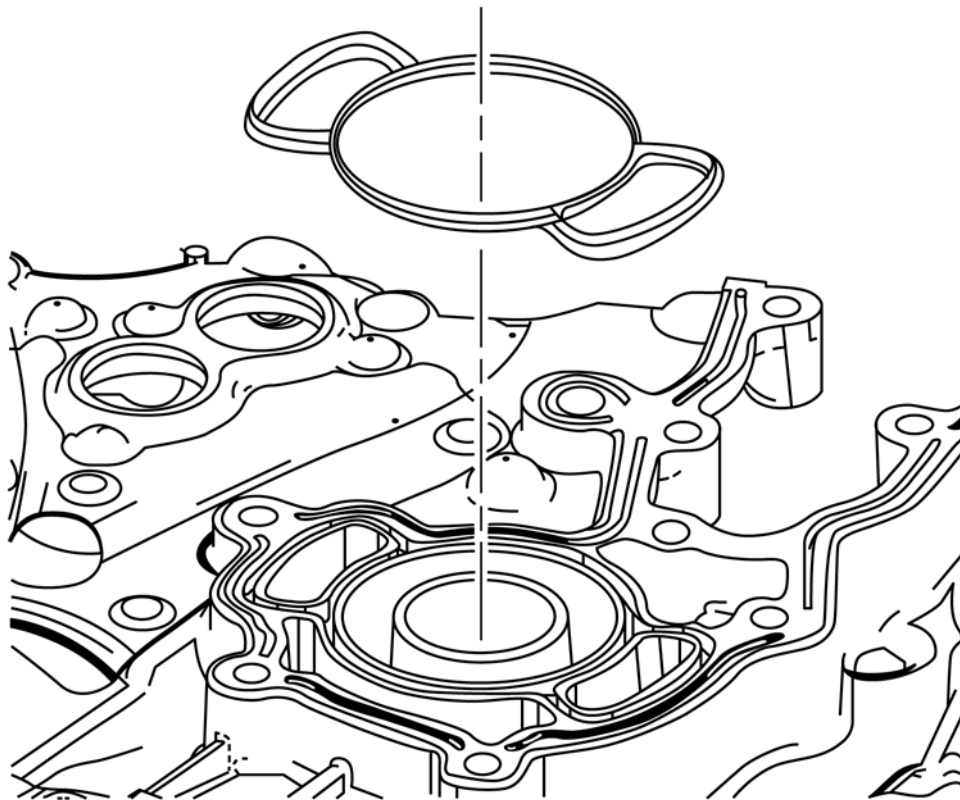

FIG. A17.17 Location of Front Cover Seal

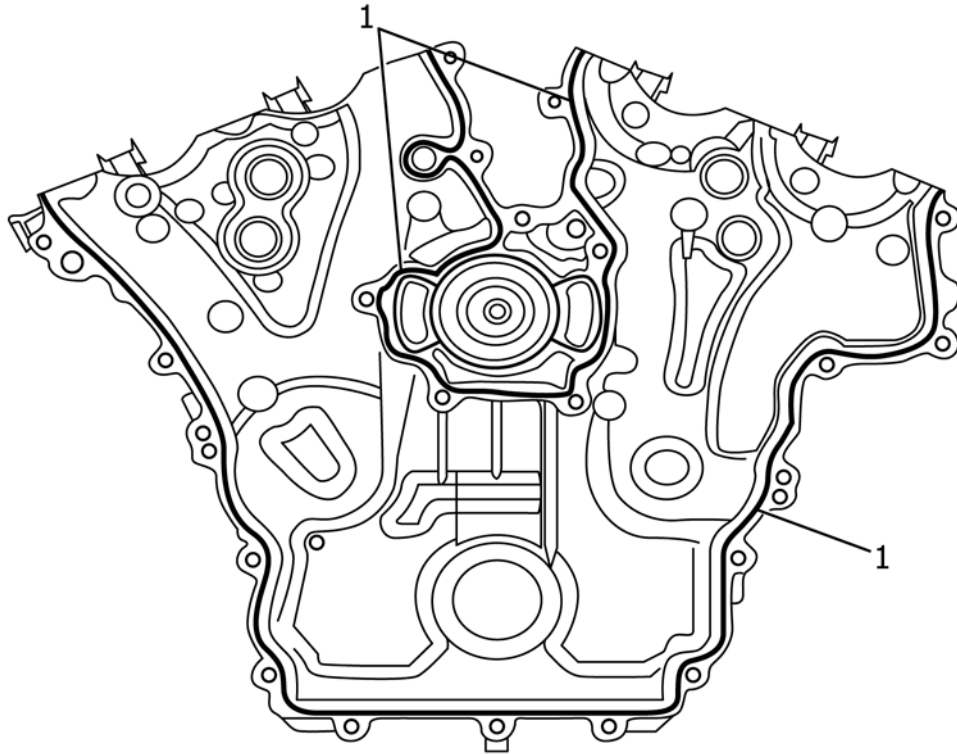

FIG. A17.18 Location of RTV Bead Placement

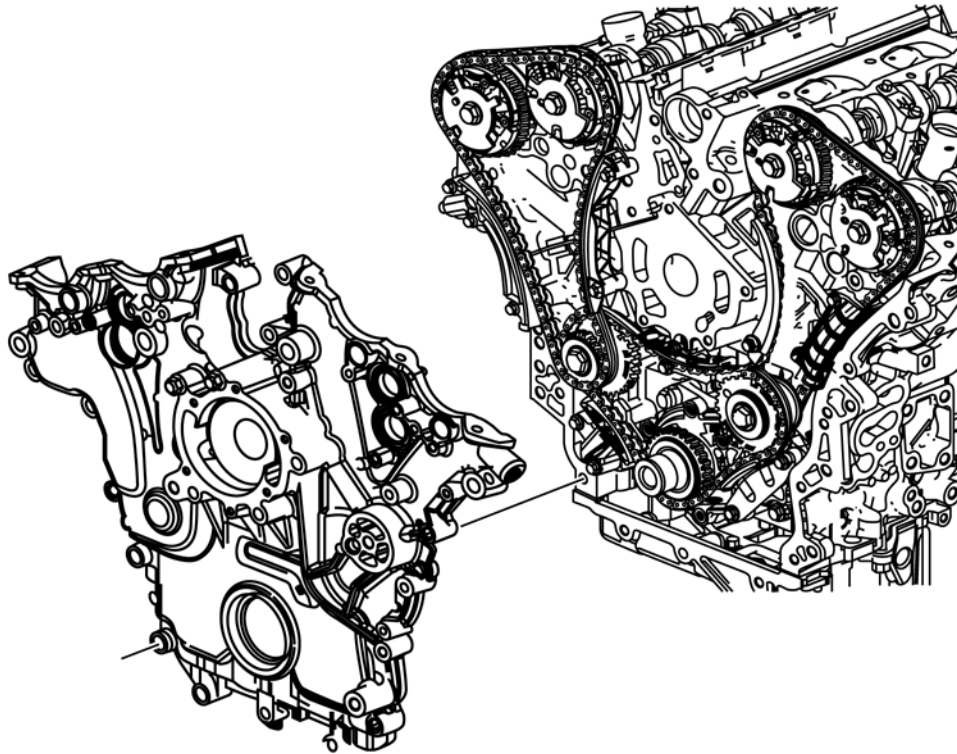

FIG. A17.19 Installation of Front Cover

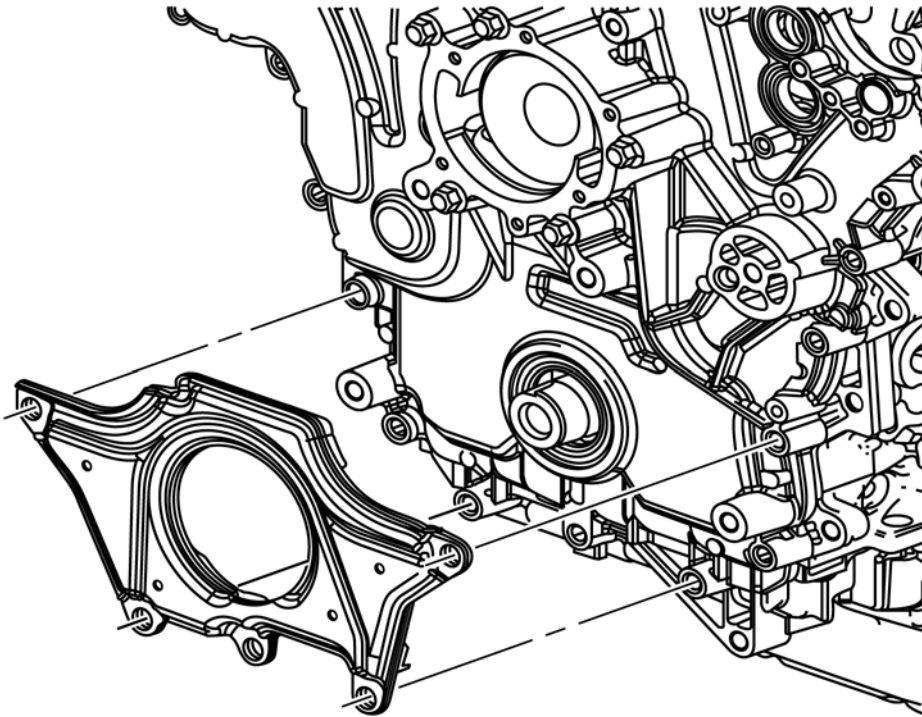

FIG. A17.20 Front Cover Sound Deadener Installation

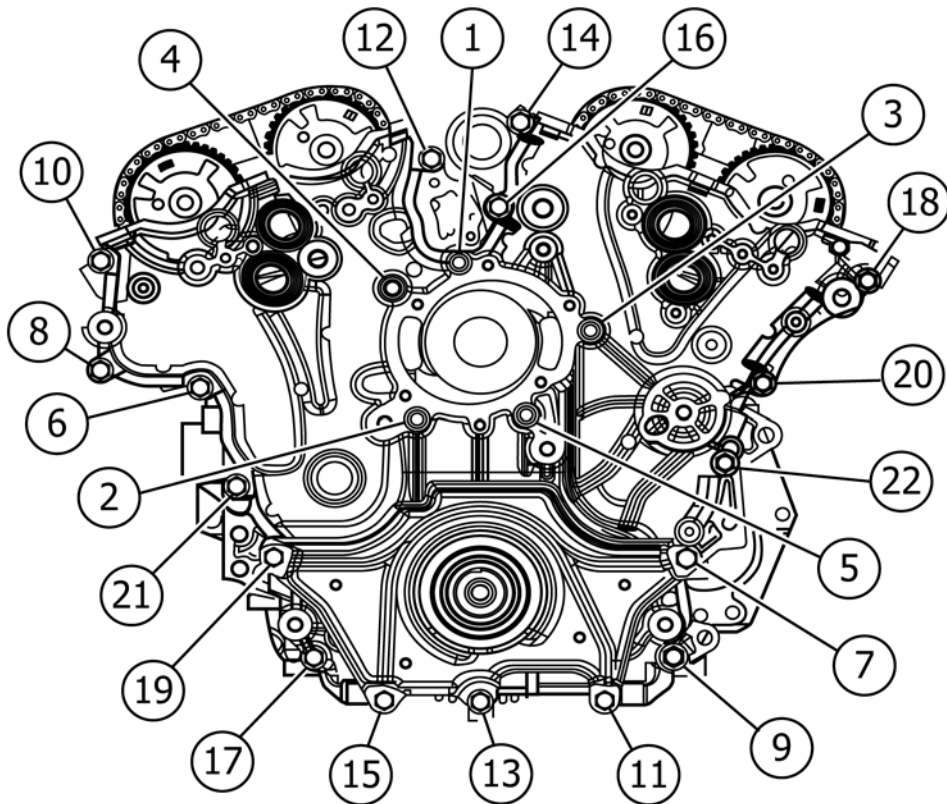

FIG. A17.21 Tightening Sequence For Front Cover

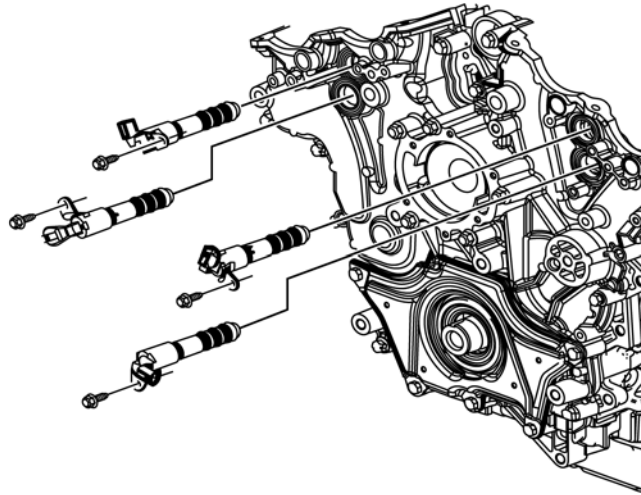

FIG. A17.22 Cam Position Actuator Location

APPENDIX

(Nonmandatory Information)

X1. PROCUREMENT OF TEST MATERIALS

INTRODUCTION

Throughout the text, references are made to necessary hardware, reagents, materials, and apparatus. In many cases, for the sake of uniformity and ease of acquisition, certain suppliers are named. If substitutions are deemed appropriate for the specified suppliers, permission in writing must be obtained from the TMC before such will be considered to be equivalent. The following entries for this appendix represent a consolidated listing of the ordering information necessary to complete the references found in the text.

X1.1 General Communications Concerning Sequence VID Reference Tests, Procedural Questions and Non-Reference Tests:

ASTM Test Monitoring Center
Attention: Administrator
6555 Penn Avenue
Pittsburgh, PA 15206-4489
Telephone: (412) 365-1005

X1.2 Reference Oils and Calibration Oils:
Purchase reference oils and calibration oils by contacting:

ASTM Test Monitoring Center
Attention: Operations Manager
6555 Penn Avenue
Pittsburgh, PA 15206-4489
Telephone: (412) 365-1010

X1.3 Test Engine:
Sequence VID engines, part No. OHT6D-099-3
OH Technologies, Inc.
9300 Progress Parkway
P.O. Box 5039
Mentor, OH 44061-5039

Telephone: (440) 354-7007
Fax (440) 354-7080

X1.4 Dynamometer:

A Midwest Model 758 (50-hp) dry gap dynamometer may be ordered from:

Midwest Dynamometer Engineering Company
3100 River Road
River Grove, IL 60171
Telephone: (708) 453-5156
Fax: (708) 453-5171

X1.5 Dynamometer Load Cell:

The recommended load cell is a Lebow Model 3397 which may be ordered from:

Honeywell
2080 Arlingate Lane
Columbus, OH 43228-4112
Telephone: (800) 867-3888

X1.6 Cooling System Pressure Cap:

A satisfactory coolant system pressure cap (70 kPa, normally closed cap) is available through local distributors.

X1.7 Cooling System Pump (P-1):

The specified cooling system pump may be obtained from:
Gould Pumps, Inc.
240 Fall Street
Seneca Falls, NY 13148

X1.8 Coolant Heat Exchanger (HX-1):

ITT (Model 320-20)
ITT Standard
175 Standard Parkway
Buffalo, NY 14227
or
Bell & Gossett (BP 75H-20 or BP 420-20)
Bell & Gossett ITT
8200 N. Austin Avenue
Morton Grove, IL 60053

X1.9 Coolant Orifice Plate (Differential Pressure):

Flowell
8308 South Regency Drive
Tulsa, OK 74131
Telephone: (918) 224-6969

X1.10 Coolant Control Valves (TCV-104, FCV-103 and TCV-101):

Badger Meter, Inc.
P.O. Box 581390
Tulsa, OK 74158
Telephone: (918) 836-8411

X1.11 Differential Pressure Transducer (DPT-1):

The recommended transducers are Viatran Model 274 or Model 374, Validyne Model DP15, and Rosemount model 1151 which may be ordered from:

Viatran Corp.
300 Industrial Drive
Grand Island, NY 14072
Telephone: (716) 773-1700
or
Validyne Engineering Corp.
8626 Wilbur Ave.
Northridge, CA 91324
Telephone: (818) 886-2057
or
Rosemount Inc.
4001 Greenbriar Street 150B
Stafford, Texas 77477
Telephone: 1-800 999-9307

X1.12 Water Pump Plate:

The water pump block off plate OHT6D-005-1 may be purchased from:
OH Technologies, Inc.
9300 Progress Parkway
P.O. Box 5039
Mentor, OH 44061-5039
Telephone: (440) 354-7007
Fax (440) 354-7080

X1.13 Oil Scavenge Pump (P-3):

Houdaille Industries, Inc.

Viking Pump Division

George and Wyeth Street
Cedar Falls, IA 50613
Telephone: (319) 266-1741

X1.14 Thermocouples:

www.omega.com
Telephone: (888) 826-6342

X1.15 Oil Circulation Pump (P-4):

Houdaille Industries, Inc.
Viking Pump Division
George and Wyeth Street
Cedar Falls, IA 50613
Telephone: (319) 266-1741

X1.16 External Oil System Solenoid Valves (FCV-150A, FCV-150C, FCV-150D, FCV-150E and FCV-150F):

Burkert Contromatic Corp.
1091 N. Batavia Street
Orange, CA 92667
Telephone: (714) 744-3230
Fax: (714) 639-4998

X1.17 External Oil System Control Valves (TCV-144 and TCV-145):

Badger Meter, Inc.
P.O. Box 581390
Tulsa, OK 74158
Telephone: (918) 836-8411

X1.18 Oil Heat Exchanger (HX-6):

ITT (Model 310-20):
ITT Standard
175 Standard Parkway
Buffalo, NY 14227
or
Bell & Gossett (Model BP 25-20 or BP 410-020):
Bell & Gossett ITT
8200 N. Austin Avenue
Morton Grove, IL 60053

X1.19 Electric Oil Heater Housing (EH-5):

TEST ENGINEERING, INC. (TEI)
12718 Cimarron Path
San Antonio, TX 78249
Telephone: (210) 690-1958
Fax: (210) 690-1959

X1.20 Oil Filter Housing Assembly OHT6A-013-2 and Filters (Screen) (FIL-2)

Racor 28 micron screen OHT6A-012-3:
OH Technologies, Inc.
9300 Progress Parkway
P.O. Box 5039
Mentor, OH 44061-5039
Telephone: (440) 354-7007
Fax: (440) 354-7080

X1.21 Modified Oil Filter Adapter Plate OHT6D-003-1:

OH Technologies, Inc.

9300 Progress Parkway
P.O. Box 5039
Mentor, OH 44061-5039
Telephone: (440) 354-7007
Fax: (440) 354-7080

X1.22 External Oil System Hose and Quick Disconnect Fittings:

Aeroquip products are available through local distributors or:
Aeroquip Corporation
Industrial Division
1225 W. Main Street
Van Wert, OH 45891
Telephone: (419) 238-1190

X1.23 Modified Oil Pan and Modified Oil Pick-Up Tube OHT6D-001-1:

The oil pan and oil level blocking plate may be purchased from:
OH Technologies, Inc.
9300 Progress Parkway
P.O. Box 5039
Mentor, OH 44061-5039
Telephone: (440) 354-7007
Fax: (440) 354-7080

X1.24 Fuel Flow Measurement Mass Flow Meter:

MicroMotion, Inc.
7070 Winchester Circle
Boulder, CO 80301
Telephone: (303) 530-8400 or (800) 522-6277
Fax: (303) 530-8209

X1.25 AFR Analyzer:

The recommended AFR analyzers are a Horiba MEXA 700 or an ECM AFM1000 that can be ordered from, respectively:
Horiba Instruments, Inc.
17671 Armstrong
Irvine Industrial Complex
Irvine, CA 92623
Telephone: (714) 250-4811
OR
Engine Control and Monitoring (ECM)
Los Altos, CA
Telephone: (408) 734-3433

X1.26 ECU (Engine Control Unit) Revision 3, OHT6D-012-4:

OH Technologies Inc.
9300 Progress Parkway
P.O. Box 5039
Mentor, OH 44061-5039
Telephone: (440) 354-7007
Fax: (440) 354-7080

X1.27 Engine Wiring Harness Without Interface OHT6D-011-2:

OH Technologies Inc.

9300 Progress Parkway
P.O. Box 5039
Mentor, OH 44061-5039
Telephone: (440) 354-7007
Fax: (440) 354-7080

X1.28 Modified Coolant Inlet:

The coolant inlet may be purchased from:
OH Technologies Inc.
9300 Progress Parkway
P.O. Box 5039
Mentor, OH 44061-5039
Telephone: (440) 354-7007
Fax: (440) 354-7080

X1.29 Organic Solvent (Penmul L460):

Penetone Corporation
74 Hudson Avenue
Tenafly, NJ 07670

X1.30 Degreasing Solvent:

Available from local suppliers.

X1.31 Damper drivelines may be purchased from:

Machine Service Inc.
<http://www.machineservice.com/contact.htm>
American VULKAN Corporation
2525 Dundee Road,
Winterhaven, FL 33884
(863)-324-2424

X1.32 Engine Mounts:

OH Technologies Inc.
9300 Progress Parkway
P.O. Box 5039
Mentor, OH 44061-5039
Telephone: (440) 354-7007
Fax: (440) 354-7080

X1.33 Test Fuel:

Haltermann Products
1201 South Sheldon Road
PO BOX 429
Channelview, TX 77530-0429
Telephone: 281-457-2768

X1.34 Order parts specified as “available from CPD” from:

OH Technologies Inc.
9300 Progress Parkway
P.O. Box 5039
Mentor, OH 44061-5039
Telephone: (440) 354-7007
Fax: (440) 354-7080

X1.35 Paxton Fuel Pressure Regulator

Can be obtained from Summit Racing
960 East Glendale Avenue
Sparks, NV 89431
www.summitracing.com

SUMMARY OF CHANGES

Subcommittee D02.B0.10 has identified the location of selected changes to this standard since the last issue (D7589 – 15a) that may impact the use of this standard. (Approved April 1, 2016.)

(1) Subsection **6.6.5.5** revised to allow the use of another oil cooling heat exchanger.

Subcommittee D02.B0.10 has identified the location of selected changes to this standard since the last issue (D7589 – 15) that may impact the use of this standard. (Approved Oct. 1, 2015.)

(1) Introduction revised.

(2) **Annex A1** revised, new **Annex A2 – Annex A4** added, with standardized wording describing the functions of the TMC. Subsequent Annex sections were renumbered.

(3) Subsection **6.6.5.11**, added an oil pan displacement block.

(4) Sections **10** and **13**, revised.

(5) **Table 8**, revised.

Subcommittee D02.B0.10 has identified the location of selected changes to this standard since the last issue (D7589 – 14) that may impact the use of this standard. (Approved Feb. 1, 2015.)

(1) Subsection **7.2.2** revised to clarify proper usage of existing and new fuel batches.

ASTM International takes no position respecting the validity of any patent rights asserted in connection with any item mentioned in this standard. Users of this standard are expressly advised that determination of the validity of any such patent rights, and the risk of infringement of such rights, are entirely their own responsibility.

This standard is subject to revision at any time by the responsible technical committee and must be reviewed every five years and if not revised, either reapproved or withdrawn. Your comments are invited either for revision of this standard or for additional standards and should be addressed to ASTM International Headquarters. Your comments will receive careful consideration at a meeting of the responsible technical committee, which you may attend. If you feel that your comments have not received a fair hearing you should make your views known to the ASTM Committee on Standards, at the address shown below.

This standard is copyrighted by ASTM International, 100 Barr Harbor Drive, PO Box C700, West Conshohocken, PA 19428-2959, United States. Individual reprints (single or multiple copies) of this standard may be obtained by contacting ASTM at the above address or at 610-832-9585 (phone), 610-832-9555 (fax), or service@astm.org (e-mail); or through the ASTM website (www.astm.org). Permission rights to photocopy the standard may also be secured from the Copyright Clearance Center, 222 Rosewood Drive, Danvers, MA 01923, Tel: (978) 646-2600; <http://www.copyright.com/>