



Standard Test Method for John Deere Coolant Cavitation Test¹

This standard is issued under the fixed designation D7583; the number immediately following the designation indicates the year of original adoption or, in the case of revision, the year of last revision. A number in parentheses indicates the year of last reapproval. A superscript epsilon (ϵ) indicates an editorial change since the last revision or reapproval.

1. Scope

1.1 This test method is commonly referred to as the John Deere Cavitation Test.² The test method defines a heavy-duty diesel engine to evaluate coolant protection as related to cylinder liner pitting caused by cavitation.

1.2 The values stated in SI units are to be regarded as the standard. The values given in parentheses are for information only. The only exception is where there is no direct SI equivalent such as screw threads, national pipe threads/diameters, and tubing sizes.

1.3 *This standard does not purport to address all of the safety concerns, if any, associated with its use. It is the responsibility of the user of this standard to establish appropriate safety and health practices and determine the applicability of regulatory limitations prior to use. See Annex A1 for general safety precautions.*

1.4 *Table of Contents:*

¹ This test method is under the jurisdiction of ASTM Committee D15 on Engine Coolants and Related Fluids and is the direct responsibility of Subcommittee D15.11 on Heavy Duty Coolants.

Current edition approved April 1, 2016. Published May 2016. Originally approved in 2009. Last previous edition approved in 2009 as D7583-09. DOI: 10.1520/D7583-16.

² American Society for Testing and Materials takes no position respecting the validity of any patent rights asserted in connection with any item mentioned in this standard. Users of this standard are expressly advised that determination of the validity of any such patent rights, and the risk of infringement of such rights, are entirely their own responsibility.

Scope	1
Referenced Documents	2
Terminology	3
Summary of Test Method	4
Significance and Use	5
Apparatus	6
Test Engine Configuration	6.1
Test Engine	6.1.1
Test Stand Configuration	6.2
Engine Mounting	6.2.1
Intake Air System	6.2.2
Aftercooler	6.2.3
Exhaust System	6.2.4
Fuel System	6.2.5
Coolant System	6.2.6
Oil System	6.2.7
Oil Volume	6.2.7.1
Pressurized Oil Fill System	6.2.7.2
External Oil System	6.2.7.3
Oil Sample Valve Location	6.2.7.4
Unacceptable Oil System Materials	6.2.7.5
Crankcase Aspiration	6.3
Blowby Rate	6.4
System Time Responses	6.5
Clearance Measurements	6.6
Engine and Cleaning Fluids	7
Engine Oil	7.1
Test Fuel	7.2
Test Coolant	7.3
Solvent	7.4
Preparation of Apparatus	8
Cleaning of Parts	8.1
General	8.1.1
Engine Block	8.1.2
Cylinder Head	8.1.3
Rocker Cover and Oil Pan	8.1.4
External Oil System	8.1.5

Rod Bearing Cleaning and Measurement	8.1.6	Warm-Up	10.3.3
Ring Cleaning and Measurement	8.1.7	Warm-up Conditions	10.3.3.1
Injector Nozzle	8.1.8	Shutdown during Warm-up	10.3.3.2
Pistons	8.1.9	20-Hour Steady State Extended Break-in	10.3.4
Engine Assembly	8.2	20-Hour Steady State Extended Break-in Conditions	10.3.4.1
General	8.2.1	Shutdown during 20-Hour Extended Break-in	10.3.4.2
Parts Reuse and Replacement	8.2.2	230-Hour Cyclic	10.4
Build-Up Oil	8.2.3	230-Hour Cyclic Conditions	10.4.1
Coolant Thermostat	8.2.4	Shutdown during 230-Hour Cyclic	10.4.2
Fuel Injectors	8.2.5	Shutdown and Maintenance	10.5
New Parts	8.2.6	Normal Shutdown	10.5.1
Operational Measurements	8.3	Emergency Shutdown	10.5.2
Units and Formats	8.3.1	Maintenance	10.5.3
Instrumentation Calibration	8.3.2	Downtime	10.5.4
Fuel Consumption Rate Measurement Calibration	8.3.2.1	Operating conditions	10.6
Temperature Measurement Calibration	8.3.2.2	Stage Transition Times	10.6.1
Pressure Measurement Calibration	8.3.2.3	Test Timer	10.6.2
Temperatures	8.3.3	Operational Data Acquisition	10.6.3
Measurement Location	8.3.3.1	Operational Data Reporting	10.6.4
Coolant Out Temperature	8.3.3.2	Coolant Sampling	10.6.5
Coolant In Temperature	8.3.3.3	Oil Sampling	10.6.6
Fuel In Temperature	8.3.3.4	End of Test (EOT)	10.7
Oil Gallery Temperature	8.3.3.5	Shutdown	10.7.1
Intake Air Temperature	8.3.3.6	Oil Drain	10.7.2
Intake Air after Compressor Temperature	8.3.3.7	Coolant Drain	10.7.3
Intake Manifold Temperature	8.3.3.8	Engine Disassembly	10.7.4
Exhaust Temperature	8.3.3.9	Calculations, Ratings and Test Validity	11
Exhaust after Turbo Temperature	8.3.3.10	Liner Pit Count	11.1
Additional Temperatures	8.3.3.11	Coolant Analysis	11.2
Pressures	8.3.4	Oil Analyses	11.3
Measurement Location and Equipment	8.3.4.1	Assessment of Operational Validity	11.4
Condensation Trap	8.3.4.2	Report	12
Coolant Pressure	8.3.4.3	Report Forms	12.1
Fuel Pressure	8.3.4.4	Reference Coolant Test	12.2
Oil Gallery Pressure	8.3.4.5	Electronic Transmission of Test Results	12.3
Intake Air Pressure	8.3.4.6	Precision and Bias	13
Intake Air after Compressor Pressure	8.3.4.7	Precision	13.1
Intake Manifold Pressure	8.3.4.8	Intermediate Precision Conditions	13.1.1
Exhaust after Turbo Pressure	8.3.4.9	Intermediate Precision Limit	13.1.2
Crankcase Pressure	8.3.4.10	Reproducibility Conditions	13.2
Additional Pressures	8.3.4.11	Reproducibility Limit	13.2.1
Flow Rates	8.3.5	Bias	13.3
Flow Rate Location and Measurement Equipment	8.3.5.1	Keywords	14
Blowby	8.3.5.2	Annexes	
Fuel Flow	8.3.5.3	Safety Precautions	Annex A1
Engine/Stand Calibration and Non-Reference Coolant Tests	9	Intake Air Aftercooler	Annex A2
General	9.1	Engine Build Parts Kit	Annex A3
New Test Stand	9.2	Sensor Locations, Special Hardware, and Engine Block Modifications	Annex A4
New Test Stand Calibration	9.2.1	Fuel Specifications	Annex A5
Stand Calibration Period	9.3	John Deere Service Publications	Annex A6
Stand Modification and Calibration Status	9.4	Specified Units and Formats	Annex A7
Test Numbering System	9.5	Report Forms and Data Dictionary	Annex A8
General	9.5.1	Coolant Analysis	Annex A9
Reference Coolant Tests	9.5.2	Oil Analysis	Annex A10
Non-Reference Coolant Tests	9.5.3	Determination of Operational Validity	Annex A11
Reference Coolant Test Acceptance	9.6	Typical System Configurations	Appendix X1
Reference Coolant Accountability	9.7		
Last Start Date	9.8		
Donated Reference Coolant Test Programs	9.9		
Adjustments to Reference Coolant Calibration Periods	9.10		
Procedure Development	9.10.1		
Parts and Fuel Shortages	9.10.2		
Reference Coolant Test Data Flow	9.10.3		
Special Use of The Reference Coolant Calibration System	9.10.4		
Procedure	10		
Engine Installation and Stand Connections	10.1		
Break-in	10.2		
Coolant System Fill for Break-in	10.2.1		
Oil Fill for Break-in	10.2.2		
Engine Build Committed	10.2.3		
Break-in Conditions	10.2.4		
Shutdown during Break-in	10.2.5		
250-Hour Test Procedure	10.3		
Coolant System Fill for Test	10.3.1		
Zero-Hour Coolant Sample	10.3.1.1		
Oil Fill for Test	10.3.2		
Zero-Hour Oil Sample	10.3.2.1		

2. Referenced Documents

2.1 ASTM Standards:³

- [D86 Test Method for Distillation of Petroleum Products and Liquid Fuels at Atmospheric Pressure](#)
- [D93 Test Methods for Flash Point by Pensky-Martens Closed Cup Tester](#)
- [D97 Test Method for Pour Point of Petroleum Products](#)
- [D130 Test Method for Corrosiveness to Copper from Petroleum Products by Copper Strip Test](#)

³ For referenced ASTM standards, visit the ASTM website, www.astm.org, or contact ASTM Customer Service at service@astm.org. For *Annual Book of ASTM Standards* volume information, refer to the standard's Document Summary page on the ASTM website.

D235 Specification for Mineral Spirits (Petroleum Spirits) (Hydrocarbon Dry Cleaning Solvent)

D287 Test Method for API Gravity of Crude Petroleum and Petroleum Products (Hydrometer Method)

D445 Test Method for Kinematic Viscosity of Transparent and Opaque Liquids (and Calculation of Dynamic Viscosity)

D482 Test Method for Ash from Petroleum Products

D524 Test Method for Ramsbottom Carbon Residue of Petroleum Products

D613 Test Method for Cetane Number of Diesel Fuel Oil

D664 Test Method for Acid Number of Petroleum Products by Potentiometric Titration

D976 Test Method for Calculated Cetane Index of Distillate Fuels

D1121 Test Method for Reserve Alkalinity of Engine Coolants and Antirusts

D1177 Test Method for Freezing Point of Aqueous Engine Coolants

D1287 Test Method for pH of Engine Coolants and Antirusts

D1319 Test Method for Hydrocarbon Types in Liquid Petroleum Products by Fluorescent Indicator Adsorption

D2274 Test Method for Oxidation Stability of Distillate Fuel Oil (Accelerated Method)

D2500 Test Method for Cloud Point of Petroleum Products

D2622 Test Method for Sulfur in Petroleum Products by Wavelength Dispersive X-ray Fluorescence Spectrometry

D2709 Test Method for Water and Sediment in Middle Distillate Fuels by Centrifuge

D4052 Test Method for Density, Relative Density, and API Gravity of Liquids by Digital Density Meter

D4485 Specification for Performance of Active API Service Category Engine Oils

D4737 Test Method for Calculated Cetane Index by Four Variable Equation

D5185 Test Method for Multielement Determination of Used and Unused Lubricating Oils and Base Oils by Inductively Coupled Plasma Atomic Emission Spectrometry (ICP-AES)

D5302 Test Method for Evaluation of Automotive Engine Oils for Inhibition of Deposit Formation and Wear in a Spark-Ignition Internal Combustion Engine Fueled with Gasoline and Operated Under Low-Temperature, Light-Duty Conditions (Withdrawn 2003)⁴

D5844 Test Method for Evaluation of Automotive Engine Oils for Inhibition of Rusting (Sequence IID) (Withdrawn 2003)⁴

D5967 Test Method for Evaluation of Diesel Engine Oils in T-8 Diesel Engine

E29 Practice for Using Significant Digits in Test Data to Determine Conformance with Specifications

E202 Test Methods for Analysis of Ethylene Glycols and Propylene Glycols

E344 Terminology Relating to Thermometry and Hydrometry

3. Terminology

3.1 Definitions:

3.1.1 *blind reference coolant, n*—a reference coolant, the identity of which is unknown by the test facility.

3.1.2 *blowby, n*—in internal combustion engines, the combustion products and unburned air-and-fuel mixture that enter the crankcase. **D5302**

3.1.3 *calibrate, v*—to determine the indication or output of a measuring device with respect to that of a standard. **E344**

3.1.4 *heavy-duty, adj*—in internal combustion engine operation, characterized by average speed, power output, and internal temperatures that are close to the potential maximum. **D4485**

3.1.5 *heavy-duty engine, n*—in internal combustion engines, one that is designed to allow operation continuously at or close to its peak output. **D4485**

3.1.6 *non-reference coolant, n*—any coolant other than a reference coolant, such as a research formulation, commercial coolant or candidate coolant. **D5844**

3.1.7 *non-standard test, n*—a test that is not conducted in conformance with the requirements in the standard test method; such as running in an non-calibrated test stand or using different test equipment, applying different equipment assembly procedures, or using modified operating conditions. **D5844**

3.1.8 *reference coolant, n*—a coolant of known performance characteristics, used as a basis for comparison.

3.1.9 *test coolant, n*—any coolant subjected to evaluation in an established procedure.

3.1.10 *wear, n*—the loss of material from, or relocation of material on, a surface.

3.1.10.1 *Discussion*—Wear generally occurs between two surfaces moving relative to each other, and is the result of mechanical or chemical action or by a combination of mechanical and chemical actions. **D5302**

3.2 Definitions of Terms Specific to This Standard:

3.2.1 *cylinder liner, n*—in internal combustion engines, the replaceable cylinders in which the pistons move up and down and combustion takes place.

3.2.2 *overhead, n*—in internal combustion engines, the components of the valve train located in or above the cylinder head.

3.2.3 *valve train, n*—in internal combustion engines, the series of components, such as valves, crossheads, rocker arms, push rods and camshaft, that open and close the intake and exhaust valves.

4. Summary of Test Method

4.1 This test engine is a John Deere six-cylinder 10.1 L (6101H). Test operation includes a 19-min engine break-in, a 20-h coolant break-in, and 230-h in five cyclic steps.

4.2 Prior to each test, the engine is cleaned and assembled with new cylinder liners and gaskets.

⁴ The last approved version of this historical standard is referenced on www.astm.org.

4.3 The test stand is equipped with the appropriate instrumentation to control engine speed, fuel flow, and other operating parameters.

4.4 Coolant performance is characterized by determining the total liner pit count area.

5. Significance and Use

5.1 This test method was developed to evaluate the ability of a heavy-duty diesel engine coolant to provide protection against damage resulting from a phenomenon known as cylinder liner cavitation corrosion.

5.2 This test method may be used for engine coolant specification acceptance when all details of this test method are in compliance.

5.3 The design of the engine used in this test method is a production OEM diesel engine modified to consistently produce the operating conditions that accelerate damage from cylinder liner cavitation. This factor, along with the accelerated operating conditions needs to be considered when extrapolating test results.

6. Apparatus

6.1 *Test Engine Configuration:*

6.1.1 *Test Engine*—The John Deere 6101H is an inline six-cylinder heavy duty diesel engine with 10.1 L of displacement and is turbocharged and aftercooled. The engine has an overhead valve configuration. It features mechanical control of fuel metering and fuel injection timing.

6.1.2 *Oil Pan Modification*—Modify the oil pan as shown in Fig. A4.9.

6.2 *Test Stand Configuration:*

6.2.1 *Engine Mounting*—Install the engine so that it is upright and the crankshaft is horizontal.

6.2.1.1 The engine mounting hardware should be configured to minimize block distortion when the engine is fastened to the mounts. Excessive block distortion may influence test results.

6.2.2 *Intake Air System*—With the exception of the intake air tube, the intake air system is not specified. A typical configuration is shown in Fig. X1.1. The air filter should be typical of air filters used for engines in heavy-duty applications. Install the intake air tube (Fig. A4.2) near the intake of the turbocharger compressor. The system shall allow control of applicable parameters listed in Table 1 and Table 2.

6.2.3 *Aftercooler*—Use a Modine aftercooler. Instructions for obtaining the correct aftercooler are listed in A2.1.

NOTE 1—Difficulty in achieving or maintaining intake manifold pressure or intake manifold temperature, or both, may be indicative of insufficient or excessive restriction.

6.2.4 *Exhaust System*—Install the exhaust tube (Fig. A4.7) near the discharge flange of the turbocharger turbine housing. The piping downstream of the exhaust tube is not specified. A method to control exhaust pressure is required.

6.2.5 *Fuel System*—The fuel supply and filtration system is not specified. A typical configuration is shown in Fig. X1.2. The fuel consumption rate is determined by measuring the rate of fuel flowing into the day tank. A method to control the fuel temperature is required.

6.2.6 *Coolant System*—The system configuration is not specified. A typical configuration consists of a non-ferrous core heat exchanger, a reservoir (expansion tank), a temperature control valve, and a vent line from the coolant vent block on the engine to the bottom of the expansion tank as shown in Fig. X1.3. This is a non-pressurized system. The system should have a sight glass to detect air entrapment.

6.2.7 *Oil System:*

6.2.7.1 *Oil Volume*—Although the system volume is not specified, an excessively large volume may increase the time required for the engine fluid temperatures to attain specification. A system volume of 50.5 L or less, including the volume contained in the engine, has proven satisfactory.

6.2.7.2 *Pressurized Oil Fill System*—The oil fill system is not specified. A typical configuration includes an electric pump, a 50-L reservoir, and a transfer hose. The location for the pressurized fill is located on the filter head (Fig. A4.12).

6.2.7.3 *External Oil System*—Configure the external oil system according to Fig. A4.12. Use a 10 to 13 L container for the external oil reservoir. Use Viking Pump model number SG053514. Nominal pump motor speed is 1725 r/min.

6.2.7.4 *Oil Sample Valve Location*—Locate the oil sample valve on the return line from the external oil system to the engine. Locate the valve as close to the return pump as possible (Fig. A4.11).

6.2.7.5 *Unacceptable Oil System Materials*—Brass or copper fittings can influence used oil wear metals analyses and shall not be used in the external oil system.

6.3 *Crankcase Aspiration*—Vent the blowby gas at the port located on the left side of the valve cover (Fig. A4.10). Route

TABLE 1 230-Hour Test Sequence Controlled Conditions^A

Parameter	Unit	Stage				
		Low Idle	Peak Torque	Full Load	Over Speed	Fast Idle
Stage Length	min	1.5	1	4	1	0.5
Speed	r/min	900 ± 5	1500 ± 5	2100 ± 5	2300 ± 5	2500 ± 5
Power	kW	record	record	record	record	record
Torque (typical) ^A	N·m	0 ± 5	1680 ± 10	1220 ± 10	1080 ± 10	0 ± 5
Intake Manifold Temperature ^A	°C	93 ± 5	100 ± 5	100 ± 5	100 ± 5	100 ± 5
Coolant Out Temperature ^A	°C	70 ± 2	70 ± 2	70 ± 2	70 ± 2	70 ± 2
Fuel In Temperature	°C	40 ± 2	40 ± 2	40 ± 2	40 ± 2	40 ± 2
Turbo Compressor Inlet Temperature ^A	°C	30 ± 2	30 ± 2	30 ± 2	30 ± 2	30 ± 2
Exhaust Pressure	kPa	record	record	5 ± 1	record	record

^A Intended set point, but may vary due to cyclic conditions.

TABLE 2 230-Hour Test Sequence Typical Conditions

Parameter	Unit	Stage				
		Low Idle	Peak Torque	Full Load	Over Speed	Fast Idle
Fuel Flow	Kg/h	0 ± 1	40 ± 1	68 ± 1	68 ± 1	45 ± 1
Blowby Flow	l/min	85 ± 2	311 ± 2	311 ± 2	283 ± 2	141 ± 2
Coolant In Temperature	°C	56 ± 2	66 ± 2	63 ± 2	61 ± 2	61 ± 2
Oil Gallery Temperature	°C	82 ± 2	83 ± 2	89 ± 2	91 ± 2	90 ± 2
Intake Manifold Pressure	kPa	≥1	≥70	≥70	≥70	≥55
Exhaust Temperature	°C	260 ± 100	705 ± 100	760 ± 100	760 ± 100	427 ± 100
Fuel Pressure	kPa	record	record	record	record	record
Oil Gallery Pressure	kPa	record	record	record	record	record
Coolant Inlet Pressure	kPa	record	record	record	record	record
Coolant Outlet Pressure	kPa	record	record	record	record	record
Coolant System Pressure	kPa	open	open	open	open	open
Crankcase Pressure	kPa	record	record	record	record	record
Inlet Air Pressure	kPa	record	record	record	record	record

the vent line downward from the valve cover port to the blowby canister. The line shall be between 1.2 and 1.8 m in length and minimum 15.9 mm inside diameter.

6.4 Blowby Rate—The flow rate measurement device is not specified. The blowby canister shall be a minimum of 35 L in volume. The outlet of the blowby canister to the flow rate device shall be a minimum of 31.8 mm inside diameter. The hose connecting the blowby canister to the flowrate device shall be a minimum of 38.1 mm inside diameter. The length of this hose is not specified.

6.5 System Time Responses—The maximum allowable system time responses are shown in [Table 3](#).

6.6 Clearance Measurements—Piston skirt outside diameter and liner inside diameter, piston pin, rod and main bearings.

6.6.1 Piston Skirt—Measure and record the piston skirt outside diameter.

Spec = 130.04–130.05 mm, max

6.6.2 Main Bearings—Inspect the crankshaft main bearings for condition and clearance. The crankshaft will have to be supported to perform the plastigage clearance check.

Spec = 0.046–0.152 mm, max

6.6.3 Rod Bearings—Inspect the crankshaft main bearings for condition and clearance. The crankshaft will have to be supported to perform the plastigage clearance check.

Spec = 0.046–0.152 mm, max

6.6.4 Cylinder Liners—Measure and record the cylinder liners inside diameter.

OEM liner ID spec = 130.165–130.175 mm
 Test liner ID spec = Piston Skirt OD + 0.254 mm
 Test liner OD spec = Block ID – 0.1016 mm

6.6.5 Piston Ring End Gap—Measure and record the piston ring end gap and the oil control ring side clearance.

Spec Top = 0.432–0.686 mm
 2nd = 1.016–1.27 mm
 Oil = 0.330–0.635 mm
 OCSC = 0.061–0.102 mm
 New Max Used = 0.165 cm

6.6.6 Piston Pin to Connecting Rod Bushing—Measure and record the piston pin to connecting rod bushing clearance.

Spec = 0.018–0.762 mm

6.6.7 Connecting Rod Bearing Clearance—Install the pistons and connecting rods. Use plastigage to measure the connecting rod bearing clearance.

Spec = 0.051–0.127 mm

6.6.8 Cylinder Head—Measure and record the cylinder head specifications as per [Table 4](#).

7. Engine and Cleaning Fluids

7.1 Engine Oil—Approximately 70 L of John Deere Plus 50 TY6391 is required to complete the test.

7.2 Test Fuel—Approximately 4500 gal of Off-Highway diesel fuel is required to complete the test. Fuel property tolerances are shown in [Annex A5](#).

TABLE 4 Cylinder Head Rebuild Specifications

Head Flatness	0.1016 mm entire length or width
Head Thickness	166.294 to 166.802 mm
Intake Valve Stem OD	9.462 to 9.487 mm
Exhaust Valve Stem OD	9.436 to 9.462 mm
Valve Guide ID	9.512 to 9.538 mm
Valve Guide Installed Height	36.170 to 39.167 mm
Intake Valve to Guide Clear	0.025 to 0.127 mm
Exhaust Valve to Guide Clear	0.051 to 0.152 mm
Valve Seat Run Out	0.051 mm max
Intake Spring Tension Closed	35.3802 to 40.82331 kg at 52.578 mm
Intake Spring Tension Open	82.55381 to 89.81129 kg at 38.1 mm
Exhaust Spring Tension Closed	29.02991 to 34.47302 kg at 54.61 mm
Exhaust Spring Tension Open	81.19303 to 88.45051 kg at 38.608 mm
Intake Valve Seat Angle	29.5 to 30.5 degrees
Exhaust Valve Seat Angle	37 to 38 degrees
Intake Valve Recession	2.692 to 3.327 mm
Exhaust Valve Recession	1.626 to 2.286 mm
Intake Valve Lash	0.330 to 0.432 mm
Exhaust Valve Lash	0.584 to 0.686 mm
Intake Seat Width	1.600 to 2.997 mm
Exhaust Seat Width	1.194 to 2.997 mm

TABLE 3 Maximum Allowable System Time Responses

Measurement	Time Response (s)
Speed	2.0
Temperature	3.0
Pressure	3.0
Flow	15.0

7.3 *Engine Coolant*—Use specified test coolant mixed with deionized water.

7.4 *Solvent*—Use a solvent which meets Specification **D235** for mineral spirits, Type II, Class C for Aromatic Content (0–2 % vol), Flash Point (142°F / 61°C, min), and Color (not darker than +25 on Saybolt Scale or 25 on Pt-Co Scale).⁵ Obtain a Certificate of Analysis for each batch of solvent from the supplier. (**Warning**—Combustible. Health Hazard. Use adequate safety precautions with all solvents and cleaners.)

8. Preparation of Apparatus

8.1 *Cleaning of Parts:*

8.1.1 *General*—The preparation of test engine components specific to the John Deere Coolant Cavitation Test are indicated in this section. Use the John Deere publication CTM61 (13MAY93) 6101 Component Technical Manual⁶ for preparation of other engine parts. Take precautions to prevent rusting of iron components.

8.1.2 *Engine Block*—Disassemble the engine, including removal of the pistons and cylinder liners. Thoroughly clean the surfaces and oil passages (galleries). Removal of camshaft bearings is at the discretion of the laboratory.

8.1.3 *Cylinder Head*—Disassemble and clean the cylinder head. Use a brush as necessary to remove deposits.

8.1.4 *Rocker Cover and Oil Pan*—Clean the rocker cover and oil pan. Use a brush as necessary to remove deposits.

8.1.5 *External Oil System*—Flush the internal surfaces of the oil lines and the external reservoir with solvent. Repeat until the solvent drains clean. Flush solvent through the oil pumps until the solvent drains clean.

8.1.6 *Rod Bearing Cleaning and Measurement:*

8.1.6.1 Clean the rod bearings with Stoddard solvent. Use a non-metallic soft bristle brush if necessary. Avoid handling the rod bearings with bare hands. Use gloves or plastic covered tongs.

8.1.6.2 Spray the rod bearings with air until dry.

8.1.6.3 Rinse the rod bearings in pentane and dry with air.

8.1.6.4 Perform the plastigage clearance check (0.051–0.127 cm max).

8.1.7 *Ring Cleaning and Measurement:*

8.1.7.1 After the piston rings have been removed from the piston use carburetor cleaner or Stoddard solvent to soften the carbon deposits. Once the deposits have softened use a hand held brass wire brush or a brass pick to remove the carbon deposits. Scotch-Brite (3M part number 7440) may also be used to help remove carbon deposits. Once the piston rings have had all of the carbon removed spray them down with Stoddard solvent and dry them with compressed air. Place the piston rings in clean numbered bags for later measurement and installation on the pistons. Avoid handling the rings with bare hands. Use gloves or plastic covered tongs.

8.1.8 *Injector Nozzle:*

8.1.8.1 Verify nozzle retaining nut torque is tightened to 88 N·m.

8.1.8.2 Test nozzle for opening pressure, leakage, chatter, and spray pattern per the CTM61 component technical manual.

8.1.9 *Pistons*—Care must be taken in cleaning the pistons in order to prolong life.

8.1.9.1 After the pistons have been removed from the connecting rods remove loose carbon and oil by washing the pistons in hot soapy water or Stoddard solvent.

8.1.9.2 Carefully remove the piston rings with ring pliers and place them in numbered plastic bags.

8.1.9.3 Soak the pistons in carburetor cleaner until the carbon deposits are softened, then wash the pistons in hot soapy water to neutralize the carburetor cleaner.

8.1.9.4 Remove any remaining carbon deposits with a hand held brass wire brush or a brass pick.

8.1.9.5 When all of the carbon deposits have been removed from the pistons spray them down with solvent and dry them with compressed air.

8.1.9.6 Place the pistons in clean numbered bags for later measurement and installation.

8.2 *Engine Assembly:*

8.2.1 *General*—Except as noted in this section, use the procedures indicated in the John Deere CTM61 (13MAY93) Component Technical Manual. Assemble the engine with new liners and gaskets.

8.2.2 *Parts Reuse and Replacement*—Engine components may be reused or replaced at the discretion of the laboratory, except as noted in 8.2.6.

8.2.3 *Build-Up Oil*—Use John Deere Plus 50 SAE 15w-40.

8.2.4 *Coolant Thermostat*—Lock the engine coolant thermostat open.

8.2.5 *Fuel Injectors*—The fuel injectors may be reused. Dedicate the injectors to a particular cylinder.

8.2.6 *New Parts*—The only standard new parts are liners and gaskets.

8.3 *Operational Measurements:*

8.3.1 *Units and Formats*—See **Annex A7**.

8.3.2 *Instrumentation Calibration:*

8.3.2.1 *Fuel Consumption Rate Measurement Calibration*—Calibrate the fuel consumption rate measurement system before every reference test sequence and at least once every twelve months. Temperature-compensate volumetric systems, and calibrate them against a mass flow device. The flow meter located on the test stand shall indicate within 0.2 % of the calibration standard. Trace the calibration standard to national standards.

8.3.2.2 *Temperature Measurement Calibration*—Calibrate the temperature measurement systems before every reference test sequence and at least once every twelve months. Each temperature measurement system shall indicate within $\pm 0.5^\circ\text{C}$ of the laboratory calibration standard. Trace the calibration standard to national standards.

8.3.2.3 *Pressure Measurement Calibration*—Calibrate the pressure measurement systems before every reference test sequence and at least once every twelve months. Trace the calibration standard to national standards.

8.3.3 *Temperatures:*

8.3.3.1 *Measurement Location*—The temperature measurement locations are specified in this section. The measurement

⁵ Cleaning solvent that meets the requirements of 7.4 is available from local petroleum products suppliers.

⁶ Available from <http://www.deere.com>.

equipment is not specified. Install the sensors such that the tip is located midstream of the flow unless otherwise indicated. The accuracy and resolution of the temperature measurement sensors and the complete measurement system shall follow the guidelines detailed in ASTM Research Report RR:D02-1218.⁷

8.3.3.2 *Coolant Out Temperature*—Install the sensor in a ¼ in. NPT hole at the top of the coolant out tube (Fig. A4.4).

8.3.3.3 *Coolant In Temperature*—Install the sensor located on the right side of the coolant pump intake housing in a ¼ in. NPT hole (Fig. A4.3).

8.3.3.4 *Fuel In Temperature*—Install the sensor in a ¼ in. NPT hole located on the side of the injector pump (Fig. A4.5).

8.3.3.5 *Oil Gallery Temperature*—Install the sensor in a ¼ in. NPT hole located at the right rear of the engine (Fig. A4.8).

8.3.3.6 *Intake Air Temperature*—Install the sensor in a ¼ in. NPT hole located approximately 26 in. from the compressor inlet (Fig. A4.2).

8.3.3.7 *Intake Air after Compressor Temperature*—Install the sensor in a ¼ in. NPT hole located approximately 24 in. from the compressor outlet (Fig. A4.1).

8.3.3.8 *Intake Manifold Temperature*—Install the sensor in a ¼ in. NPT hole located approximately 24 in. from the modine outlet (Fig. A4.1).

8.3.3.9 *Exhaust Temperature*—Install the sensors on the center flange of the exhaust manifold as per Fig. A4.6.

8.3.3.10 *Exhaust after Turbo Temperature*—Install the sensor in a ¼ in. NPT hole located approximately 48 in. from the turbo outlet (Fig. A4.7).

8.3.3.11 *Additional Temperatures*—Monitor any additional temperatures considered to be beneficial.

8.3.4 Pressures:

8.3.4.1 *Measurement Location and Equipment*—The pressure measurement locations are specified in this section. The measurement equipment is not specified. The accuracy and resolution of the pressure measurement sensors and the complete measurement system shall follow the guidelines detailed in ASTM Research Report RR:D02-1218.⁷

8.3.4.2 *Condensation Trap*—A condensation trap should be installed at the lowest elevation of the tubing between the pressure measurement location and the final pressure sensor for Crankcase Pressure, Intake Air Pressure, and Exhaust Pressure. Route the tubing to avoid intermediate loops or low spots before and after the condensation trap.

8.3.4.3 *Coolant Pressure*—Tank is open to atmosphere.

8.3.4.4 *Fuel Pressure*—Measure the pressure at the ¼ in. NPT hole located on the side of the injector pump (Fig. A4.5).

8.3.4.5 *Oil Gallery Pressure*—Measure the pressure at the ¼ in. NPT hole located at the right rear of the engine (Fig. A4.8).

8.3.4.6 *Intake Air Pressure*—Measure the pressure at the ¼ in. NPT hole located approximately 26 in. from the compressor inlet (Fig. A4.2).

8.3.4.7 *Intake Air Pressure after Compressor*—Measure the pressure at the ¼ in. NPT hole located approximately 24 in. from the compressor outlet (Fig. A4.1).

8.3.4.8 *Intake Manifold Pressure*—Measure the pressure at the ¼ in. NPT hole located approximately 24 in. from the modine outlet (Fig. A4.1).

8.3.4.9 *Exhaust after Turbo Pressure*—Measure the pressure at the ¼ in. NPT hole located approximately 48 in. from the turbo outlet (Fig. A4.7).

8.3.4.10 *Crankcase Pressure*—Measure the pressure at the boss on the top-front, left-hand side of the rocker cover (Fig. A4.10).

8.3.4.11 *Additional Pressures*—Monitor any additional pressures considered to be beneficial.

8.3.5 Flow Rates:

8.3.5.1 *Flow Rate Location and Measurement Equipment*—The flow rate measurement locations are specified in this section. The equipment for the blowby rate and the fuel rate are not specified. The accuracy and resolution of the flow rate measurement system shall follow the guidelines detailed in ASTM Research Report RR:D02-1218.⁷

8.3.5.2 *Blowby*—The device used to measure the blowby flow rate is not specified. See 6.4 for blowby measurement system configuration details.

8.3.5.3 *Fuel Flow*—The fuel consumption rate is determined by measuring the fuel flowing to the day tank (Fig. X1.2).

9. Engine/Stand Calibration and Non-Reference Oil Tests

9.1 *General*—Calibrate the test stand by conducting a test with the designated reference coolant. Submit the results to the ASTM Test Monitoring Center (TMC) for determination of acceptance according to the Lubricant Test Monitoring System (LTMS).⁸

9.2 *New Test Stand*—A new test stand is defined as a test stand that has never been calibrated.

9.2.1 *New Test Stand Calibration*—New stand calibration is determined according to the LTMS.⁸

9.3 *Stand Calibration Period*—The calibration period is 12 months for all calibration periods. Up to 12 operationally valid, non-reference coolant tests may be completed during each calibration period.

9.3.1 The TMC may schedule more frequent reference coolant tests or extend the calibration period.

9.4 *Stand Modification and Calibration Status*—Stand calibration status may be invalidated by conducting any non-standard test or modification of the test and control systems or both. A non-standard test includes any test conducted under a modified procedure, non-procedural hardware, controller set-point modifications, or any combination thereof. The TMC should be contacted prior to any changes to determine the effect on the calibration status.

9.5 Test Numbering System:

9.5.1 *General*—The test number has three parts, W-X-Y-Z. W represents the test stand number, X represents the stand run

⁷ Supporting data have been filed at ASTM International Headquarters and may be obtained by requesting Research Report RR:D02-1218. Contact ASTM Customer Service at service@astm.org.

⁸ Available from the ASTM Test Monitoring Center at Carnegie Mellon University, 6555 Penn Avenue, Pittsburgh, PA 15206, <http://www.astmtmc.cmu.edu>.

number, Y represents the engine serial number, and Z represents the block run number. For example, test number 27-10-4B4607-2 indicates stand number 27, stand test number 10, engine serial number 4B4607, and the second test on engine number 4B4607.

9.5.2 *Reference Coolant Tests*—The block run number shall be 1 for the first reference attempt. If a second attempt must be made the block run number shall be 2, etc. For example, if two consecutive reference coolant tests were conducted and the first test number was 27-10-4B4607-1, the second test number would be 27-11-4B4607-2 etc.

9.5.3 *Non-Reference Coolant Tests*—Increment X and Z by one for each non-reference test start.

9.6 *Reference Coolant Test Acceptance:*

9.6.1 Reference coolant test acceptance is determined in accordance with the LTMS.⁸

9.7 *Reference Coolant Accountability:*

9.7.1 Laboratories shall provide a full accounting of the identification and quantities of all reference coolant used. No physical or chemical analyses of reference coolant shall be performed without written permission from the TMC. In such an event, include the written confirmation and the data generated in the reference coolant test report.

9.7.2 Retain used reference coolant samples for 90 days from the EOT date.

9.8 *Last Start Date*—In order for a non-reference coolant test to be within a calibration period, the assembled engine shall be cranked (10.3.3) prior to the expiration of the calibration period (9.3).

9.9 *Donated Reference Coolant Test Programs*—The surveillance panel is charged with maintaining effective reference coolant test severity and precision monitoring. During times of new parts introductions and procedural revisions, it may be necessary to evaluate the possible effects on severity and precision levels. The surveillance panel may choose to conduct a program of donated reference coolant tests in those laboratories participating in the monitoring system, in order to quantify the effect of a particular change on severity and precision. Typically, the surveillance panel requests its panel members to volunteer enough reference coolant test results to create a robust data set. Broad laboratory participation is needed to provide a representative sampling of the industry. To ensure the quality of the data obtained, donated tests are conducted on calibrated test stands. The surveillance panel shall arrange an appropriate number of donated tests and ensure completion of the test program in a timely manner.

9.10 *Adjustments to Reference Coolant Calibration Periods:*

9.10.1 *Procedural Deviations*—On occasions when a laboratory becomes aware of a significant deviation from the test method, such as might arise during an in-house review or a TMC inspection, the laboratory and the TMC shall agree on an appropriate course of action to remedy the deviation. This action may include the shortening of existing reference coolant calibration periods.

9.10.2 *Parts and Fuel Shortages*—Under special circumstances, such as industry-wide parts or fuel shortages,

the surveillance panel may direct the TMC to extend the time intervals between reference coolant tests. These extensions shall not exceed one regular calibration period.

9.10.3 *Reference Coolant Test Data Flow*—To ensure continuous severity and precision monitoring, calibration tests are conducted periodically throughout the year. There may be occasions when laboratories conduct a large portion of calibration tests in a short period of time. This could result in an unacceptably large time frame when very few calibration tests are conducted. The TMC can shorten or extend calibration periods as needed to provide a consistent flow of reference coolant test data. Adjustments to calibration periods are made such that laboratories incurred no net loss (or gain) in calibration status.

9.10.4 *Special Use of the Reference Coolant Calibration System*—The surveillance panel has the option to use the reference coolant system to evaluate changes that have potential impact on test severity and precision. This option is only taken when a program of donated tests is not feasible. The surveillance panel and the TMC shall develop a detailed plan for the test program. This plan requires all reference coolant tests in the program to be completed as close to the same time as possible, so that no laboratory/stand calibration is left in an excessively long pending status. In order to maintain the integrity of the reference coolant monitoring system, each reference coolant test is conducted so as to be interpretable for stand calibration. To facilitate the required tests and scheduling, the surveillance panel may direct the TMC to lengthen and shorten reference coolant calibration periods within laboratories such that the laboratories incur no net loss (or gain) in calibration status.

10. Procedure

10.1 *Engine Installation and Stand Connections*—Install the test engine on the stand and connect the engine to the stand support equipment.

NOTE 2—A final check of valve and injector settings is recommended at this time.

10.2 *Break-in*—Perform a break-in on each new engine build prior to the start of the 250-h test procedure.

10.2.1 *Coolant System Fill for Break-in:*

10.2.1.1 Install a new Deere RE1192 coolant filter.

10.2.1.2 Charge the cooling system with 52 L of the specified concentration of new coolant and record the weight.

10.2.1.3 *Coolant Sample*—Take a 0.5 L coolant sample at the start of the break-in.

NOTE 3—The coolant system should be pressurized to specification and checked for leaks prior to adding the engine oil.

10.2.2 *Oil Fill for Break-in:*

10.2.2.1 Install a new Deere RE44647 oil filter.⁹

10.2.2.2 Use the pressurized oil fill system (6.2.7.2) to charge the engine with 33.7 L of John Deere Torque Guard Plus 50 oil at the location shown in Fig. A4.12.

10.2.2.3 *Oil Sample*—Take a 0.25 liter oil sample at the start of the break-in.

⁹ Available from a Cummins parts distributor.

10.2.3 *Engine Build Committed*—After the test coolant has been introduced into the engine, the engine build and the test number are valid only for the respective test. However, if the engine has not been started (whereby the test parts have not been subjected to heated coolant), then the new build may be used again.

10.2.4 *Break-in Conditions*—Start the engine and proceed directly to the break-in (Table 5 and Table 6).

10.2.5 *Shutdown during Break-in*—If a shutdown occurs during the break-in, rerun the entire break-in.

10.2.6 At the completion of the break-in, perform a normal shutdown (Table 7) and shut off the engine.

10.2.7 Drain the oil from the engine and the external oil system.

10.2.8 Remove the RE44647 oil filter.

10.2.9 Properly dispose of the drain oil and oil filter.

10.2.10 Once completed, the break-in is not repeated for the respective test.

NOTE 4—Use the break-in as an opportunity to confirm engine performance and to make repairs prior to the start of the 250-h test procedure.

10.3 *250-Hour Test Procedure:*

10.3.1 *Coolant Fill for Test*—Charge the system with approximately 52 L of the specified concentration of new coolant and record the weight.

10.3.1.1 *Zero-hour Coolant Sample*—Take a 0.7 L coolant sample of the fresh coolant from the original container.

10.3.2 *Oil Fill for Test*—Use the pressurized oil fill system (6.2.7.2) to charge the engine with 33.7 kg of John Deere Plus 50 oil at the location shown in Fig. A4.12.

10.3.2.1 *Zero-hour Oil Sample*—Take a 0.4 L oil sample of the fresh oil from the original oil container.

10.3.3 *Warm Up*—This warm-up procedure is used after the break-in and every time the engine is brought up.

10.3.3.1 Start the engine and perform the warm-up (Table 8 and Table 9).

10.3.3.2 *Shutdown During Warm-up*—If a shutdown occurs during the warm-up restart the warm-up procedure.

10.3.4 *20-Hour Steady State Extended Break-in*—After the warm-up, proceed directly to the 20-Hour Steady State Extended Break-in (Table 10 and Table 11).

10.3.4.1 Run the engine at the conditions stated in the 20-Hour Steady State Extended Break-in Conditions (Table 10).

TABLE 5 Break-in Conditions

Parameter	Unit	Stage				
Stage Length	min	5	2	10	5	1
Speed	r/min	700	1150	2100	2100	2500
Torque	N·m	13.5	40	760	1186	13.5
Coolant Out Temperature	°C	70 ± 2				
Fuel In Temperature	°C	40 ± 2				
Turbo Compressor Inlet Air Temperature	°C	30 ± 2				
Intake Manifold Temperature	°C	100 ± 2				
Exhaust Pressure	kPa	3.5 ± 2				

TABLE 6 Break-in Typical Conditions

Parameter	Unit	Stage				
Fuel Flow	Kg/h	4.5	20	41	68	27
Oil Gallery Temperature	°C	85 ± 2				
Oil Gallery Pressure	kPa	380 ± 4.5				
Intake Manifold Pressure	kPa	155 ± 7				
Crankcase Pressure	kPa	71 ± 7				
Inlet Air Pressure	kPa	record				
Coolant System Pressure	kPa	open				

TABLE 7 Shutdown Conditions

Parameter	Unit	Stage	
		A	B
Stage Length	min	2	5
Speed	r/min	Ramp down to 1200	900
Torque	N·m	Ramp down to low load (~20 Nm)	No load
Coolant Out Temperature	°C	70 max	70 max
Intake Manifold Temperature	°C	100 max	100 max

TABLE 8 Warm-up Conditions

Parameter	Unit	Stage		
		A	B	C
Stage Length	min	5	5	5
Speed	r/min	900	1200	2100
Torque	N·m	0	520	766
Coolant Out Temperature	°C	70 max	70 max	70 max
Intake Manifold Temperature	°C	100 max	100 max	100 max

TABLE 9 Warm-up Typical Conditions

Parameter	Unit	Stage		
		A	B	C
Oil Gallery Temperature	°C	50	62	78

TABLE 10 20-Hour Steady State Extended Break-in Conditions

Parameter	Unit	Stage
Stage Length	h	20
Speed	r/min	2100 ± 10
Torque	N·m	766 ± 5
Coolant Out Temperature	°C	70 ± 2
Fuel In Temperature	°C	40 ± 2
Turbo Inlet Air Temperature	°C	30 ± 2
Intake Manifold Temperature	°C	100 ± 2
Exhaust Pressure	kPa	3.5 ± 2

10.3.4.2 *Shutdown During Extended Break-in*—If a shutdown occurs during the 20-Hour Extended Break-in, Stop the Test Timer and proceed to the Normal Shutdown (Table 7).

10.4 *230-Hour Cyclic*—No intervention is necessary between the 20-Hour Steady State and the 230-Hour Cyclic portions of the test.

10.4.1 Run the engine at the conditions stated in the 230-Hour Test Sequence (Table 1).

TABLE 11 20-Hour Steady State Extended Break-in Typical Conditions

Parameter	Unit	Stage
Fuel Flow	kg/h	42 ± 2
Oil Gallery Temperature	°C	85 ± 2
Intake Manifold Pressure	kPa	155 ± 7
Oil Gallery Pressure	kPa	380 ± 4.5
Crankcase Pressure	kPa	71 ± 7
Inlet Air Pressure	kPa	record
Coolant System Pressure	kPa	open
Coolant Inlet Pressure	kPa	record
Coolant Outlet Pressure	kPa	record

10.4.2 *Shutdown During 230-Hour Cyclic*—If a shutdown occurs during the 230-Hour Cyclic, Stop the Test Timer and proceed to the Normal Shutdown (Table 7).

10.5 *Shutdown and Maintenance*—The test may be shut down at the discretion of the laboratory to perform repairs. However, the intent of this test method is to conduct the 250-h test procedure without shutdowns.

10.5.1 *Normal Shutdown*—Proceed directly from the operating conditions to the shutdown schedule (Table 7).

10.5.2 *Emergency Shutdown*—An emergency shutdown occurs when the normal shutdown cannot be performed, such as an alarm condition.

10.5.3 *Maintenance*—Engine components or stand support equipment, or both, may be repaired or replaced at the discretion of the laboratory and in accordance with this test method.

10.5.4 *Downtime*—The limit for total downtime and number of shutdowns is not specified. Record all shutdowns, pertinent actions, and total downtime during the 250-h test procedure.

10.6 *Operating Conditions:*

10.6.1 *Stage Transition Times*—Less than 10 s with the exception of Intake Manifold Temperature.

10.6.2 *Test Timer*—The 250-h test timer starts when all controlled parameters in the Steady State Extended Break-in are within specification. If a shutdown occurs, stop the test timer immediately at the initiation of the shutdown. The test timer shall resume when the test has been returned to the appropriate stage and all controlled parameters are within specification.

10.6.3 *Operational Data Acquisition*—Record all operational parameters shown in Tables 1 and 10, with automated data acquisition 15 s before the end of each step.

10.6.4 *Operational Data Reporting*—The operational data is reported on Form 5 listed in Annex A8, Table A8.1.

10.6.5 *Coolant Sampling*—Take a coolant sample at the end of each 125-h period. Do not shut down the engine for coolant sampling.

10.6.5.1 *Coolant Sample*—Remove a nominal 500-mL coolant sample and retain at the stand. Identify the coolant sample container with the test number, coolant code, date, and test hour.

10.6.6 *Oil Sampling*—Take an oil sample at the end of each 50-h period before any new oil is added during the oil addition procedure. Do not shut down the engine for oil sampling and oil addition.

10.6.6.1 *Oil Sample*—Remove a nominal 250-mL purge. Remove a nominal 250-mL oil sample and retain at the stand. Return the purge to the engine oil system. Identify the oil sample container with the test number, date, and test hour.

10.6.6.2 *Oil Addition*—Verify oil adder tank is approximately 50 % full after 1 h. After the oil sampling has been completed at the end of each 50-h period, add John Deere Plus 50 as needed to return to the full mark.

10.7 *End of Test (EOT):*

10.7.1 *Shutdown*—After completing the test procedure, perform a normal shutdown (Table 7), and shut down the engine. Disconnect the test stand support equipment. (**Warning**—The coolant and oil may be hot. The installation of a valve to safely vent the coolant system pressure is recommended.)

10.7.2 *Oil Drain*—Drain the oil from the engine and the external oil system and retain at stand.

10.7.3 *Coolant Drain*—Drain the coolant from the engine and external cooling system and retain at stand.

10.7.4 *Engine Disassembly*—Disassemble the engine and remove the liners for ratings.

11. Calculations, Ratings and Test Validity

11.1 *Liner Pit Count*—Using a microscope, place the transparent grid (squares are 2.14 mm) on the liner surface over the pitted area(s) of the liner. Assign a count of one pit area to each grid square containing a pit or pits. The pit (or pits) does not have to cover the entire square. If any portion of a pit or group of pits is contained in a square, it receives a count of one. Total all the pit areas on a given liner. Total the pit areas on all six liners, and this is the total pit count for the coolant being tested.

11.2 *Coolant Analysis*—Typical coolant analysis results are itemized in Annex A9.

11.3 *Oil Analysis*—Typical oil analysis results are listed in Annex A10.

11.4 *Assessment of Operational Validity*—Determine operational validity according to Annex A11.

12. Report

12.1 *Report Forms*—For reference coolant tests the standardized report form set and data dictionary for reporting test results and for summarizing the operational data are required. The report forms and data dictionary are available from the TMC. Instructions for obtaining the report forms and data dictionary and a list of report forms are shown in Annex A8.

12.1.1 Report latest stand Reference Data, Pit Counts, Operational Summary, Coolant and Oil Analysis, Downtime, and Photographs on the appropriate form in the test report.

12.2 *Reference Coolant Test*—Send the test report forms and any other supporting information, to the TMC⁸ by facsimile or electronic transmission within five days of the EOT date for test acceptance determination. Reference oil test reports should be mailed or electronically transmitted to the TMC within 30 days of the EOT date.

12.3 *Electronic Transmission of Test Results*—Use ASTM Data Communications Committee Test Report Transmission Model (Section 2—Flat File Transmission Format).

13. Precision and Bias

13.1 *Precision*—Precision is based on operationally valid calibration test results monitored by the TMC. The research report contains industry data developed prior to the establishment of this test method.

13.1.1 *Intermediate Precision (formerly called repeatability) Conditions*—Conditions where test results are obtained with the same test method using the same test coolant, with changing conditions such as operators, measuring equipment, test stands, test engines, and time.

13.1.2 *Intermediate Precision Limit (i.p.)*—The difference between two results obtained under intermediate precision conditions that would in the long run, in the normal and correct conduct of the test method, exceed the values shown in **Table 1** in only one case in twenty.

13.2 *Reproducibility Conditions*—Conditions where test results are obtained with the same test method using the same test coolant in different laboratories with different operators using different equipment.

13.2.1 *Reproducibility Limit (R)*—The difference between two results obtained under reproducibility conditions that would, in the long run, in the normal and correct conduct of the test method, exceed the values in **Table 7** in only one case in twenty.

13.3 *Bias*—Bias is determined by applying a defined statistical technique to calibration test results. When a significant bias is determined, a severity adjustment is applied to the non-reference coolant test result.

14. Keywords

14.1 cavitation; engine coolant; heavy duty; liner pitting; piston liners

ANNEXES

(Mandatory Information)

A1. SAFETY PRECAUTIONS

A1.1 The operation of engine tests may expose personnel and facilities to safety hazards. Personnel trained and experienced with engine testing should perform the design, installation, and operation of test stands.

A1.2 Guards (shields) should be installed around all external moving, hot, or cold components. Design the guard to contain the energy level of a rotating component should the component break free. Fuel, oil, coolant and electrical wiring should be properly routed, guarded, grounded and kept in good order.

A1.3 The test stand should be kept free of oil and fuel spills and tripping hazards. Containers of oil or fuel, or both, should not be permitted to accumulate in the testing area. Fire fighting equipment should be immediately accessible. Normal precautions should be observed whenever using flammable solvents for cleaning purposes.

A1.4 Safety masks, glasses, or hearing protection, or a combination thereof, should be worn by personnel working on

the test stand. No loose or flowing clothing, including long hair or other accessory to dress, should be worn near rotating equipment. Personnel should be cautioned against working alongside the engine and driveline while the engine is running.

A1.5 Interlocks should automatically shut down the engine when an anomaly of any of the following occur: engine or dynamometer coolant temperature, engine oil pressure, dynamometer field current, engine speed, exhaust temperature, excessive vibration or when the fire protection system is activated. The interlock should include a method to cut off the fuel supply to the engine at the injector pump (including the return line). A remote fuel cut off station (external to the test stand) is recommended.

A1.6 Employ other safety precautions as required by regulations.

A2. INTAKE AIR AFTERCOOLER

A2.1 Obtain the Modine aftercooler from a Mack Truck dealer. Order the aftercooler using part number 5424 03 928 031. This is a non-stocked part in the Mack Parts Distribution System and will appear as an invalid part number.

Instruct the dealer to expedite the aftercooler on a Ship Direct purchase order. The aftercooler will be shipped directly from Modine, bypassing the normal Mack Parts Distribution System.

A3. ENGINE BUILD PARTS KIT

A3.1 See [Table A3.1](#).

TABLE A3.1 Engine Build Parts Kit

Description	Part Number	Priority	Quantity
Cam Follower Parts			
Injector Nozzle	RE48480	As Required	6
Injector Return O-Ring	R77551	As Required	6
Injector Washer	R84472	As Required	6
Holder Fuel Injector	RE48359	As Required	6
Cylinder Head Parts			
Valve (Intake)	R101304	As Required	6
Valve (Exhaust)	R101305	As Required	6
Valve Stem Cap	T20129	As Required	12
Valve Shield	RE57234	As Required	12
Valve Insert (Intake)	R102860	As Required	6
Valve Insert (Exhaust)	R102859	As Required	6
Valve Retainer	T20077	As Required	12
Valve Spring	R91822	As Required	12
Overhead Components			
Rocker Lever (Intake)	AR69901	As Required	6
Rocker Lever (Exhaust)	AR69902	As Required	6
Rocker Lever Shaft	AR92514	As Required	12
Bearings			
Rod Bearing (Std)	AR101271	As Required	6
Main Bearing (Std)	AR101268	As Required	6
Main Bearing Thrust	AR101269	As Required	1
Thrust Washer	AR89622	As Required	1
Connecting Rod Bolt	R66453	As Required	12
Gaskets			
Gasket Set	RE524384	Each Test	1
Gasket Oil Pan	R64828	As Required	1
Gasket Cylinder Head	R112725B / RE34009	As Required	1
Gasket Exhaust Manifold Outer	R86454 / R80970	As Required	1
Gasket Exhaust Manifold Inner	R86455 / R80969	As Required	1
Gasket Intake Manifold	R40088	As Required	1
Gasket Water Manifold	R88397	As Required	1
Gasket Thermostat Housing	R81274	As Required	1
Gasket Valve Cover	R74365	As Required	1
Gasket Breather	R49492	As Required	1
Gasket Oil Pump	R100569 / R69418	As Required	1
Pistons/Rings/Liners^A			
Piston	RE42231	As Required	6
Piston Ring (1 set)	AR82355	Each Test	6
Piston Pin	R64451	As Required	6
Piston Retaining Ring	R51168	As Required	12
Piston & Liner Kit	RE40476	As Required	6
Cylinder Liner Packing (Upper)	R66309	Each Test	6
Cylinder Liner Packing (Center)	R57495	Each Test	6
Cylinder Liner Packing (Lower)	R57496	Each Test	6
Cylinder Liner Packing Set	AR72351	Each Test	6
Miscellaneous Parts			
Exhaust Manifold (Front)	R120570	As Required	1
Exhaust Manifold (Rear)	R120571	As Required	1
Turbo	RE53399	As Required	1
Water Pump	SE500897 / RE42155	As Required	1
Oil Filter	RE44647	Each Test	1
Coolant Filter	R11992	Each Test	1
Fuel Filter	AR86745	Each Test	1
Packing Fuel Small	R51936	Each Test	14
Packing Fuel Large	R79605	Each Test	6

^A The sole source of supply of the Liners known to the committee at this time is Richland LTD, P.O. Box 489, 481 East Hoxie Street, Spring Green, WI 53588. If you are aware of alternative suppliers, please provide this information to ASTM International Headquarters. Your comments will receive careful consideration at a meeting of the responsible technical committee,¹ which you may attend.

TABLE A3.2 Non-Kit Parts Available from ReGen Technologies

Description	P/N	Critical Part
6101H Complete Engine	XXXX	
Engine Block	XXXX	Y
Cylinder Head	XXXX	Y

A4. SENSOR LOCATIONS, SPECIAL HARDWARE, AND ENGINE BLOCK MODIFICATIONS



FIG. A4.1 Intake Manifold Temperature and Pressure Location



FIG. A4.2 Intake Air Temperature and Pressure Location



FIG. A4.3 Coolant In Temperature and Pressure Location



FIG. A4.4 Coolant Out Temperature and Pressure Location

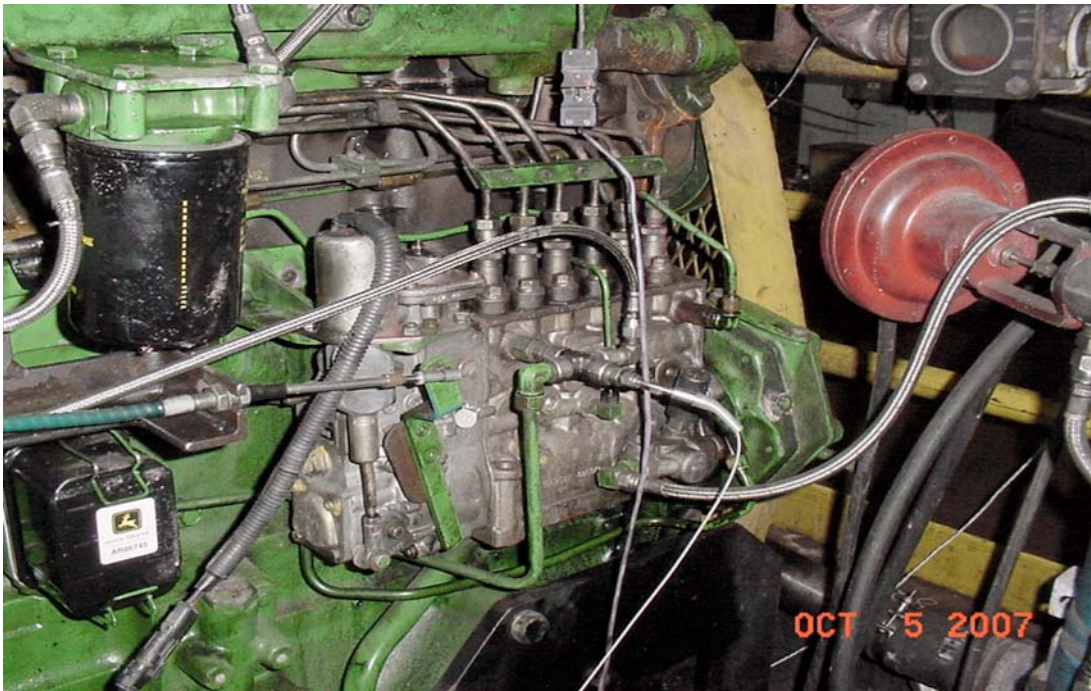

FIG. A4.5 Fuel In Temperature and Pressure Location

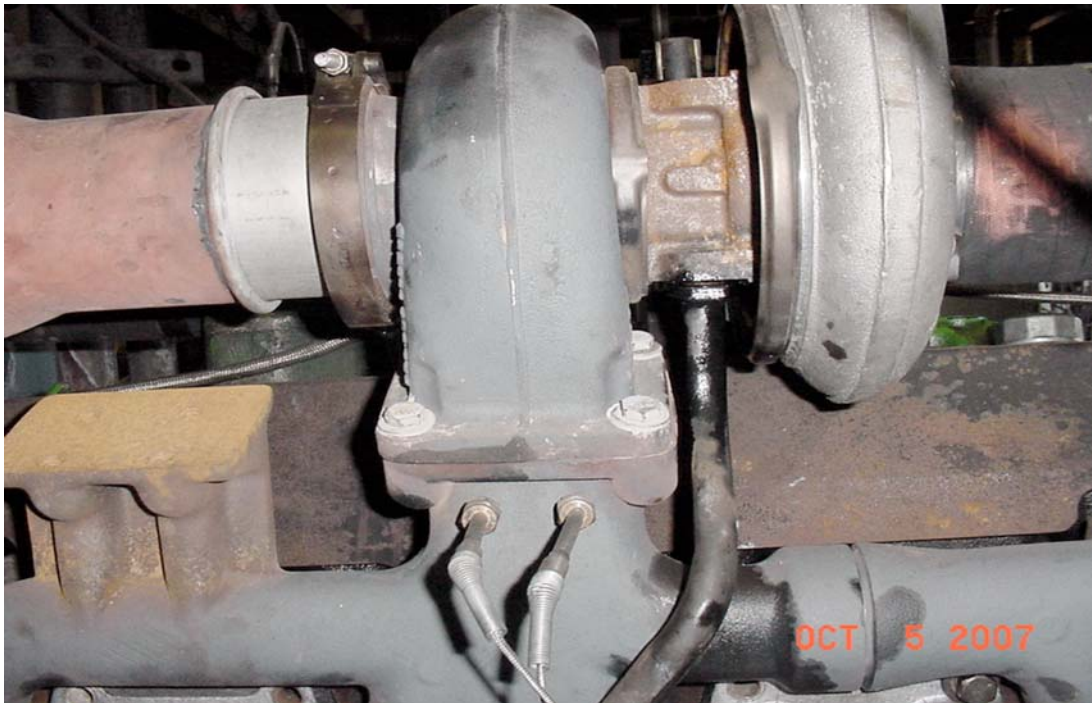

FIG. A4.6 Exhaust Temperature Location



FIG. A4.7 Exhaust After Turbo Temperature and Pressure Location



FIG. A4.8 Oil Gallery Temperature and Pressure Location



FIG. A4.9 Oil Pan Modifications and Oil Sump Temperature Location



FIG. A4.10 Oil Fill, Blowby, and Crankcase Pressure Location



FIG. A4.11 Oil Sample Valve Location



FIG. A4.12 External Oil System

A5. FUEL SPECIFICATIONS

TABLE A5.1 Fuel Specifications

Property	Test Method	Minimum ^A	Maximum ^A
Sulfur, % mass	D2622	0.04	0.05
Gravity, degrees API	D287 or D4052	34.5	36.5 (37)
Hydrocarbon Composition, % volume			
Aromatics	D1319 (FIA)	28 (27)	33
Olefin	D1319 (FIA)		Report
Cetane Number	D613	42 (40)	48
Cetane Index	D4737 and D976		Report
Copper Strip Corrosion	D130		1
Flash Point, °C	D93	54	
Pour Point, °C	D97		-18
Cloud Point, °C	D2500		Report
Carbon Residue on 10 % Residuum, %	D524 (10 % Bottoms)		0.35
Water and Sediment, % volume	D2709		0.05
Viscosity, cSt at 40°C	D445	2.4	3.0
Ash, % mass	D482		0.005
Total Acid Number	D664		0.05
Strong Acid Number	D664		0.00
Accelerated Stability	D2274		TBD
Distillation, °C	D86		
IBP			Report
10 %			Report
50 %			Report
90 %		282	338
EP			Report

^A Minimum and maximum numbers in parentheses are EPA Certification Fuel Specifications.

A6. JOHN DEERE SERVICE PUBLICATIONS

A6.1 General preparation techniques for John Deere 6101 engines are detailed in the John Deere publication titled, Component Technical Manual–6101 Engines, Deere Power Systems Group, CTM61 (13May93).

A7. SPECIFIED UNITS AND FORMATS

A7.1 Specified Units:

A7.1.1 The parameters in this test method are specified in metric units except for pipe fittings, tubing, tubing fittings, and Compuccheck fittings. Pipe fittings, tubing and tubing fittings are available worldwide and are not interchangeable with metric-sized equivalents because of differences in thread dimensions. Therefore no metric conversion is stated. The ports are standard straight thread and are not interchangeable with metric-sized equivalents.

A7.1.2 *Test Report*—Record operational parameters according to **Table A7.1**. Report test results in the units and with the significant digits shown in **Table A7.1**. Round test results in compliance with Practice **E29**.

A7.1.3 *Measurements and Conversions*—With the exceptions noted in **A7.1.1**, all parameters have been specified in SI units. The intent of this test method is to measure all parameters directly in SI units.

TABLE A7.1 Minimum Resolution of Recorded Measurements

Parameter	Record Data to Nearest
Speed	1 r/min
Power	1 kW
Torque	1 N·m
Fuel Flow	0.1 kg/h
Coolant In Temperature	0.1°C
Coolant Out Temperature	0.1°C
Fuel In Temperature	0.1°C
Oil Gallery Temperature	0.1°C
Intake Air Temperature	0.1°C
Exhaust (Tailpipe) Temperature	1°C
Intake Manifold Pressure	0.1 kPa
Crankcase Pressure	0.01 kPa
Exhaust Pressure	0.1 kPa

A7.1.3.1 Significant error may occur due to rounding or tolerance stacking, or both, when converting from inch-pound units to SI units.

A7.2 *Specification Format*—Specifications are listed in three formats: (1) target, (2) target and range, and (3) range with no target.

A7.2.1 *Target*—A target specification has no tolerance. Therefore the only acceptable value is the target. A representative specification format is xx.xx (target). For example, the oil pan oil charge is listed as 24.7 kg.

A7.2.1.1 A parameter with a target shall not be intentionally calibrated or controlled at a level other than the target.

A7.2.2 *Target and Range*—A target and a range specification implies the correct value is the target and the range is intended as a guide for maximum acceptable variation about

the mean. A representative specification format is xx.xx ± x.xx (target ± range). For example, the engine speed is 1800 ± 5 r/min.

NOTE A7.1—The mean of a random sample should be equivalent to the target. Operation within the range does not imply that parameter will not bias the final test results.

A7.2.3 *Range with No Target*—A range with no target specification is used when (1) the parameter is not critical and control within the range is sufficient or (2) the measurement technique is not precise, or both. A representative specification format is xx.xx – xx.xx (range_{low} – range_{high}). For example, the coolant system pressure is 99–107 kPa.

A8. REPORT FIGURES (FORMS) AND DATA DICTIONARY

A8.1 Download the actual report figures (forms) and data dictionary separately from the ASTM Test Monitoring Center Web Page at <http://www.astmtmc.cmu.edu/> or they can be obtained in hardcopy format from the TMC.

TABLE A8.1 List of Report Forms

1. Final Report Cover Sheet	Fig. A9.1 (Form 1)
2. Summary of Key Performance Measurements	Fig. A9.2 (Form 2)
3. Test Results Comparison	Fig. A9.3 (Form 3)
4. Test Results Summary	Fig. A9.4 (Form 4)
5. Operational Summary	Fig. A9.5 (Form 5)
6. Unscheduled Downtime & Maintenance Summary	Fig. A9.10 (Form 6)
7. Coolant and Oil Analysis Summary	Fig. A9.13 (Form 7)
8. Photograph Requirements	Fig. A9.14 (Form 8)

A9. COOLANT ANALYSIS

TABLE A9.1 Coolant Analysis

Sample Hour	Parameter				
	Metals ^A	RA ^B	FREEZE PtC ^C	Dilution ^D	pH ^E
0	X	X	X	X	X
0 (2 oz)			X		
20	X	X	X	X	X
125 (2 oz)			X		
125	X	X	X	X	X
250 (2 oz)			X		
250	X	X	X	X	X

^A D5185 (Ca, Cu, Fe, Mo, Mg, Pb, Si, Cl, NO₂, NO₃, PHO₄, SO₄)

^B D1121

^C D1177

^D E202

^E D1287

A10. OIL ANALYSIS
TABLE A10.1 Oil Analysis

Sample Hour	Parameter		
	Metals ^A	Vis at 100°C ^B	Soot
0	X	X	X
50	X	X	X
100	X	X	X
125	X	X	
150	X	X	X
200	X	X	X
250	X	X	X

^A **D5185** (Copper, Iron, Lead, Chromium, Aluminum)

^B **D5967** Annex 3 or **D445**
A11. DETERMINATION OF OPERATIONAL VALIDITY

A11.1 See **Table A11.1**.

TABLE A11.1 Diesel Engine Coolant Cavitation Test—Operational Summary

Laboratory:		EOT Date:		EOT Time:	
Test Number:*					
Coolant Code:					
Formulation / Stand Code:					
* Test Number is: Stand - Stand Run No. - Engine No. - Engine Run No.					
Parameter	Specification	Average	Std. Dev.	Minimum	Maximum
Engine Speed, r/min (20 h SS)	2,100 ± 15				
Torque, Nm (20 h SS)	~762				
Engine Speed, r/min (Low Idle)	>800				
Torque, Nm (Low Idle)	~0				
Engine Speed, r/min (Peak Torq)	~1,500				
Torque, Nm (Peak Torq)	>1,425				
Engine Speed, r/min (Full Load)	~2100				
Torque, Nm (Full Load)	>1,200				
Fuel Flow, kg/h (Full Load)	>61.0				
Engine Speed, r/min (FL O-Speed)	~2,310				
Torque, Nm (FL O-Speed)	>795				
Engine Speed, r/min (Fast Idle)	~2,625				
Torque, Nm (Fast Idle)	~0				
Temperatures					
Coolant Out, C (20 h SS)	70 ± 5				
Coolant Out, C (Low Idle)	70 ± 5				
Coolant Out, C (Peak Torq)	70 ± 5				
Coolant Out, C (Full Load)	70 ± 5				
Coolant Out, C (FL O-Speed)	70 ± 5				
Coolant Out, C (Fast Idle)	70 ± 5				
Intake Air, C (Low Idle)	29 ± 10				
Intake Air, C (Peak Torq)	29 ± 10				
Intake Air, C (Full Load)	29 ± 10				
Intake Air, C (FL O-Speed)	29 ± 10				
Intake Air, C (Fast Idle)	29 ± 10				
Fuel, C (Low Idle)	~40				
Fuel, C (Peak Torq)	~40				
Fuel, C (Full Load)	~40				
Fuel, C (FL O-Speed)	~40				
Fuel, C (Fast Idle)	~40				

APPENDIX

(Nonmandatory Information)

X1. TYPICAL SYSTEM CONFIGURATIONS

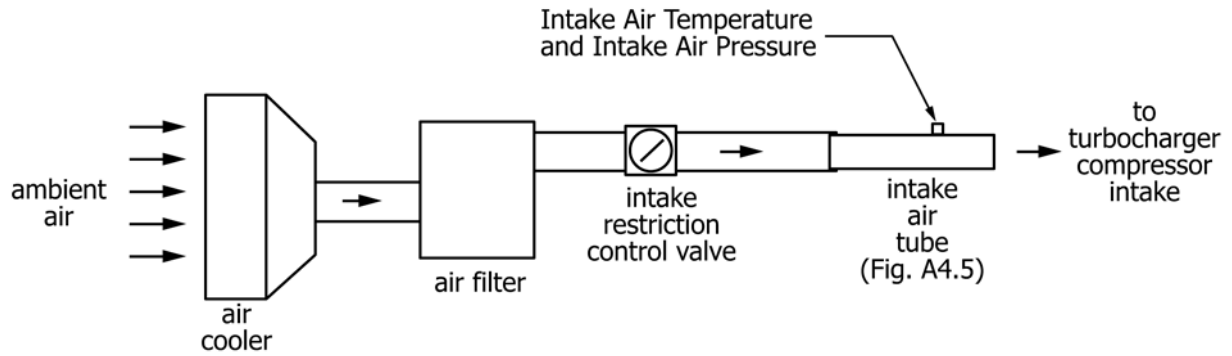
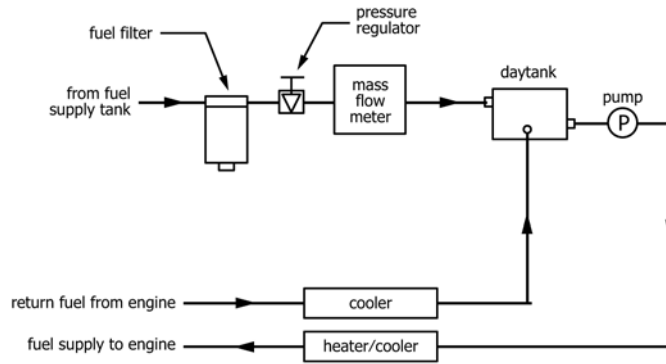

FIG. X1.1 Intake Air System (Typical)



Heating or cooling, or both, may be necessary to maintain fuel temperature.

NOTE 1—Heating or cooling, or both, may be necessary to maintain fuel temperature.

FIG. X1.2 Fuel System (Typical)

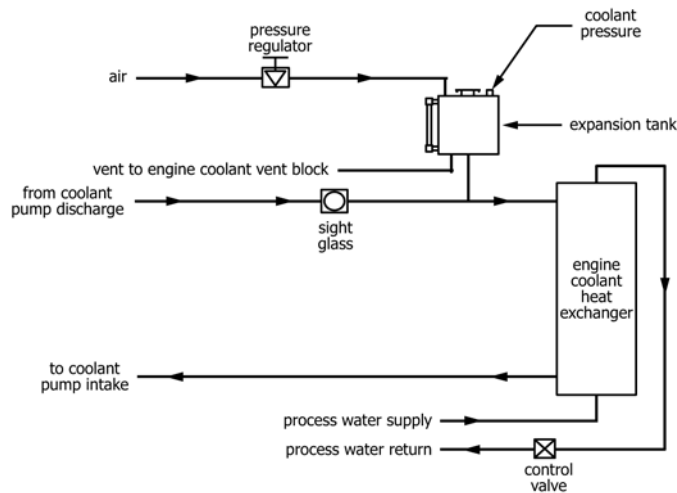

FIG. X1.3 Coolant System (Typical)

ASTM International takes no position respecting the validity of any patent rights asserted in connection with any item mentioned in this standard. Users of this standard are expressly advised that determination of the validity of any such patent rights, and the risk of infringement of such rights, are entirely their own responsibility.

This standard is subject to revision at any time by the responsible technical committee and must be reviewed every five years and if not revised, either reapproved or withdrawn. Your comments are invited either for revision of this standard or for additional standards and should be addressed to ASTM International Headquarters. Your comments will receive careful consideration at a meeting of the responsible technical committee, which you may attend. If you feel that your comments have not received a fair hearing you should make your views known to the ASTM Committee on Standards, at the address shown below.

This standard is copyrighted by ASTM International, 100 Barr Harbor Drive, PO Box C700, West Conshohocken, PA 19428-2959, United States. Individual reprints (single or multiple copies) of this standard may be obtained by contacting ASTM at the above address or at 610-832-9585 (phone), 610-832-9555 (fax), or service@astm.org (e-mail); or through the ASTM website (www.astm.org). Permission rights to photocopy the standard may also be secured from the Copyright Clearance Center, 222 Rosewood Drive, Danvers, MA 01923, Tel: (978) 646-2600; <http://www.copyright.com/>