



Designation: D7549 – 17

Standard Test Method for Evaluation of Heavy-Duty Engine Oils under High Output Conditions—Caterpillar C13 Test Procedure¹

This standard is issued under the fixed designation D7549; the number immediately following the designation indicates the year of original adoption or, in the case of revision, the year of last revision. A number in parentheses indicates the year of last reapproval. A superscript epsilon (ϵ) indicates an editorial change since the last revision or reapproval.

INTRODUCTION

Any properly equipped laboratory, without outside assistance, can use the test procedure described in this test method. The ASTM Test Monitoring Center (TMC)² provides calibration and an assessment of the test results obtained on those oils by the laboratory. By this means the laboratory will know whether its use of the test method gives results statistically similar to those obtained by other laboratories. Furthermore, various agencies require that a laboratory utilizes the TMC services in seeking qualification of oils against specifications. For example, the U.S. Army has such a requirement in some of its engine oil specifications. Accordingly, this test method is written for those laboratories that use the TMC services. Laboratories that choose not to use these services should ignore those portions of the test method that refer to the TMC. Information letters² issued periodically by the TMC may modify this test method. In addition the TMC may issue supplementary memoranda related to the test method.

1. Scope*

1.1 The test method covers a heavy-duty engine test procedure under high output conditions to evaluate engine oil performance with regard to piston deposit formation, piston ring sticking and oil consumption control in a combustion environment designed to minimize exhaust emissions. This test method is commonly referred to as the Caterpillar C13 Heavy-Duty Engine Oil Test.³

1.2 The values stated in SI units are to be regarded as standard. No other units of measurement are included in this standard.

1.2.1 *Exceptions*—Where there are no SI equivalent such as screw threads, National Pipe Treads (NPT), and tubing sizes.

1.3 *This standard does not purport to address all of the safety concerns, if any, associated with its use. It is the responsibility of the user of this standard to establish appropriate safety and health practices and determine the applica-*

bility of regulatory limitations prior to use. See Annex A1 for general safety precautions.

1.4 *This international standard was developed in accordance with internationally recognized principles on standardization established in the Decision on Principles for the Development of International Standards, Guides and Recommendations issued by the World Trade Organization Technical Barriers to Trade (TBT) Committee.*

2. Referenced Documents

2.1 *ASTM Standards:*⁴

[D86 Test Method for Distillation of Petroleum Products and Liquid Fuels at Atmospheric Pressure](#)

[D93 Test Methods for Flash Point by Pensky-Martens Closed Cup Tester](#)

[D97 Test Method for Pour Point of Petroleum Products](#)

[D130 Test Method for Corrosiveness to Copper from Petroleum Products by Copper Strip Test](#)

[D235 Specification for Mineral Spirits \(Petroleum Spirits\) \(Hydrocarbon Dry Cleaning Solvent\)](#)

[D445 Test Method for Kinematic Viscosity of Transparent and Opaque Liquids \(and Calculation of Dynamic Viscosity\)](#)

[D482 Test Method for Ash from Petroleum Products](#)

¹ This test method is under the jurisdiction of ASTM Committee D02 on Petroleum Products, Liquid Fuels, and Lubricants and is the direct responsibility of Subcommittee D02.B0 on Automotive Lubricants.

Current edition approved May 1, 2017. Published June 2017. Originally published in 2009. Last previous edition approved in 2016 as D7549 – 16. DOI: 10.1520/D7549-17.

² The ASTM Test Monitoring Center will update changes in this test method by means of Information Letters. This edition includes all information letters through No. 16-1. Information Letters may be obtained by from the ASTM Test Monitoring Center, 6555 Penn Avenue, Pittsburgh, PA 15206-4489, Attention: Administrator.

³ Caterpillar Inc., Engine System Technology Development, PO Box 610, Mossville, IL 61552-0610.

⁴ For referenced ASTM standards, visit the ASTM website, www.astm.org, or contact ASTM Customer Service at service@astm.org. For *Annual Book of ASTM Standards* volume information, refer to the standard's Document Summary page on the ASTM website.

*A Summary of Changes section appears at the end of this standard

D524 Test Method for Ramsbottom Carbon Residue of Petroleum Products

D613 Test Method for Cetane Number of Diesel Fuel Oil

D664 Test Method for Acid Number of Petroleum Products by Potentiometric Titration

D975 Specification for Diesel Fuel Oils

D976 Test Method for Calculated Cetane Index of Distillate Fuels

D1319 Test Method for Hydrocarbon Types in Liquid Petroleum Products by Fluorescent Indicator Adsorption

D2274 Test Method for Oxidation Stability of Distillate Fuel Oil (Accelerated Method)

D2622 Test Method for Sulfur in Petroleum Products by Wavelength Dispersive X-ray Fluorescence Spectrometry

D2709 Test Method for Water and Sediment in Middle Distillate Fuels by Centrifuge

D3524 Test Method for Diesel Fuel Diluent in Used Diesel Engine Oils by Gas Chromatography

D4052 Test Method for Density, Relative Density, and API Gravity of Liquids by Digital Density Meter

D4175 Terminology Relating to Petroleum Products, Liquid Fuels, and Lubricants

D4294 Test Method for Sulfur in Petroleum and Petroleum Products by Energy Dispersive X-ray Fluorescence Spectrometry

D4739 Test Method for Base Number Determination by Potentiometric Hydrochloric Acid Titration

D5185 Test Method for Multielement Determination of Used and Unused Lubricating Oils and Base Oils by Inductively Coupled Plasma Atomic Emission Spectrometry (ICP-AES)

D5186 Test Method for Determination of the Aromatic Content and Polynuclear Aromatic Content of Diesel Fuels and Aviation Turbine Fuels By Supercritical Fluid Chromatography

D5453 Test Method for Determination of Total Sulfur in Light Hydrocarbons, Spark Ignition Engine Fuel, Diesel Engine Fuel, and Engine Oil by Ultraviolet Fluorescence

D5967 Test Method for Evaluation of Diesel Engine Oils in T-8 Diesel Engine

D6078 Test Method for Evaluating Lubricity of Diesel Fuels by the Scuffing Load Ball-on-Cylinder Lubricity Evaluator (SLBOCLE)

D6681 Test Method for Evaluation of Engine Oils in a High Speed, Single-Cylinder Diesel Engine—Caterpillar 1P Test Procedure

D6987/D6987M Test Method for Evaluation of Diesel Engine Oils in T-10 Exhaust Gas Recirculation Diesel Engine

E29 Practice for Using Significant Digits in Test Data to Determine Conformance with Specifications

E178 Practice for Dealing With Outlying Observations

2.2 *Other ASTM Document:*

ASTM Deposit Rating Manual 20 (formerly CRC Manual 20)⁵

3. Terminology

3.1 Definitions:

3.1.1 *blind reference oil, n*—a reference oil, the identity of which is unknown by the test facility.

3.1.1.1 *Discussion*—This is a coded reference oil that is submitted by a source independent of the test facility. **D4175**

3.1.2 *blowby, n*—in internal combustion engines, the combustion products and unburned air-and-fuel mixture that enter the crankcase. **D4175**

3.1.3 *calibrate, v*—to determine the indication or output of a measuring device with respect to that of a standard. **D4175**

3.1.4 *heavy duty, adj*—in internal combustion engine operation, characterized by average speeds, power output, and internal temperatures that are close to the potential maximums. **D4175**

3.1.5 *heavy-duty engine, n*—in internal combustion engine types, one that is designed to allow operation continuous at or close to its peak output.

3.1.5.1 *Discussion*—This type of engine is typically installed in large trucks and buses as well as farm, industrial, and construction equipment. **D4175**

3.1.6 *non-reference oil, n*—any oil other than a reference oil, such as a research formulation, commercial oil, or candidate oil. **D4175**

3.1.7 *non-standard test, n*—a test that is not conducted in conformance with the requirements in the standard test method, such running on an uncalibrated test stand, using different test equipment, applying different equipment assembly procedures, or using modified operating conditions. **D4175**

3.1.8 *reference oil, n*—an oil of known performance characteristics, used as a basis for comparison.

3.1.8.1 *Discussion*—Reference oils are used to calibrate testing facilities, to compare the performance of other oils, or to evaluate other materials (such as seals) that interact with oils. **D4175**

3.1.9 *test oil, n*—any oil subjected to evaluation in an established procedure.

3.1.9.1 *Discussion*—It can be any oil selected by the laboratory conducting the test. It could be an experimental product or a commercially available oil. Often, it is an oil that is a candidate for approval against engine oil specifications (such as manufacturers' or military specifications, and so forth). **D4175**

3.1.10 *wear, n*—the loss of material from a surface, generally occurring between two surfaces in relative motion, and resulting from mechanical or chemical action or a combination of both.

3.2 Definitions of Terms Specific to This Standard:

3.2.1 *overhead, n*—in internal combustion engines, the components of the valve train located in or above the cylinder head.

3.2.2 *tote, n*—a container, smaller in capacity than a gallon.

⁵ For Stock #TMCML20, visit the ASTM website, www.astm.org, or contact ASTM International Customer Service at service@astm.org.

3.2.3 *valve train, n*—in internal combustion engines, the series of components, such as valves, crossheads, rocker arms, push rods and camshaft that open and close the intake and exhaust valves.

3.3 Abbreviations and Acronyms:

3.3.1 *ACERT*—Advanced Combustion Emission Reduction Technology

3.3.2 *ATGC*—average top groove carbon

3.3.3 *ATGCO*—average top groove carbon offset

3.3.4 *CARB*—California Air Resources Board

3.3.5 *CAT*—acronym for Caterpillar

3.3.6 *CRC*—Coordinating Research Council

3.3.7 *DACA*—Data Acquisition and Control Automation

3.3.8 *ECM*—engine control module

3.3.9 *EOT*—end of test

3.3.10 *HC*—heavy carbon

3.3.11 *IMP*—intake manifold pressure

3.3.12 *LC*—light carbon

3.3.13 *LTMS*—Lubricant Test Monitoring System

3.3.14 *MC*—medium carbon

3.3.15 *NPT*—National Pipe Thread

3.3.16 *OC*—oil consumption

3.3.17 *P/N*—part number

3.3.18 *QI*—quality index

3.3.19 *RPTGC*—reference relative top groove carbon profile

3.3.20 *SDTGCO*—standard deviation top groove carbon outlier

3.3.21 *TGC*—top groove carbon

3.3.22 *ULSD*—ultra low sulfur diesel

4. Summary of Test Method

4.1 This test method uses a Caterpillar production C13 diesel engine (see [Annex A3](#) for ordering information and list of engine build parts). Test operation includes a 60 min engine warm-up and break-in, followed by a 4 h cool down and valve lash adjustment. After the valve lash adjustment and any other needed adjustments, a 500 h test is begun. The engine is operated under steady-state, rated-power conditions known to generate excessive piston deposits or oil consumption or both in field service. Report the total engine oil consumption as the sum of the measured volumes in 50 h increments.

4.2 Equip the test stand with the appropriate instrumentation to control engine speed, fuel flow, and other operating parameters.

4.3 Determine the engine oil performance by assessing piston deposits and ring sticking, and oil consumption.

4.3.1 Prior to each test, clean and assemble the engine with new cylinder liners, pistons, piston rings, bearings and certain valve train components. All aspects of the assembly are specified. After the test, dismantle the engine and examine and rate the parts.

4.3.2 A sample of engine oil is removed and an oil addition is made at the end of each 50 h period. The volume of the oil addition is the sum of the volume of sample plus the volume of oil consumed by the engine.

5. Significance and Use

5.1 This test method assesses the performance of an engine oil with respect to control of piston deposits and maintenance of oil consumption under heavy-duty operating conditions selected to accelerate deposit formation in a turbocharged, intercooled four-stroke-cycle diesel engine equipped with a combustion system that minimizes federally controlled exhaust gas emissions.

5.2 The results from this test method may be compared against specification requirements to ascertain acceptance.

5.3 The design of the test engine used in this test method is representative of many, but not all, diesel engines. This factor, along with the accelerated operating conditions, needs to be considered when comparing test results against specification requirements.

6. Apparatus

6.1 Test Engine Configuration:

6.1.1 *Test Engine*—The test engine is a production 2004 Caterpillar 320 kW C13 engine, designed for heavy duty on-highway truck use. It is an electronically controlled, turbocharged, after-cooled, direct injected, six cylinder diesel engine with an in-block camshaft and a four-valve per cylinder arrangement. The engine uses Caterpillar's ACERT technology featuring multiple injections per cycle and inlet valve actuation control. It features a 2004 US EPA emissions configuration with electronic control of fuel metering, fuel injection timing and inlet valve actuation timing. Critical parts that can affect piston deposit formation are specified for oil test engine use. See [Annex A3](#) for source of the test engine and critical and non-critical parts.

6.1.2 *Oil Heat Exchanger and Oil Heat System*—Replace the standard Caterpillar oil heat exchanger core with a stainless steel core, Caterpillar P/N 1Y-4026. Additionally install a remotely mounted heat exchanger. Control the oil temperature with a dedicated cooling loop and control system which is separate from the engine coolant (see [Annex A12](#)). Ensure that the oil cooler bypass valve is blocked closed.

6.1.3 *Oil Pan Modification*—Modify the oil pan as shown in [A4.1](#).

6.1.4 *Engine Control Module (ECM)*—The ECM defines the desired engine fuel timing and quantity. It also limits maximum engine speed and power. Caterpillar electronic governors are designed to maintain a speed indicated by the throttle position signal. Speed variation drives fuel demand (rack). Rack and engine speed are input to the injection duration and timing maps to determine duration and timing commands for the fuel injectors. Obtain special oil test engine control software (module P/N 250-6775) for correct maps. Contact the Caterpillar oil test representative through TMC for installation of this software. Use the Caterpillar engine technician (ET)

service software package, version 2004B or later,⁶ to monitor engine parameters, flash software, and to change power and injector trim values. Use the full dealer version purchased from a Caterpillar dealer with a yearly subscription.

6.1.5 Crankshaft Position Sensor—Sense the crankshaft position using a primary sensor at the crankshaft gear and as secondary sensor at the camshaft gear. The secondary sensor provides position information during cranking and in the event of a primary sensor position failure. *Calibrate the engine control software before starting the timed test operation.*

6.1.6 Air Compressor—Do not use the engine-mounted air compressor for this test method. Remove the air compressor and install a block-off plate kit in its place (P/N 227-2574 cover group and P/N 223-3873, plug group) (Fig. A4.5 or equivalent).

6.1.6.1 Modify the turbocharger waste-gate for manual control by replacing the supplied pressure control with a manual linkage. See Figs. A4.21-A4.23.

6.2 Test Stand Configuration:

6.2.1 Engine Mounting—Install the engine so that it is upright and the crankshaft is horizontal.

6.2.1.1 Configure the engine mounting hardware to minimize block distortion when the engine is fastened to the mounts. Excessive block distortion may influence test results.

6.2.2 Intake Air System—With the exception of the air filter and intake air tube, the intake air system is not specified. See Fig. X1.1 of a typical configuration. Use a suitable air filter. Install the intake air tube (Fig. A4.6) at the intake of the turbocharger compressor. The intake air tube is a minimum 305 mm of straight, nominal 102 mm diameter tubing. The system configuration upstream of the air tube is not specified.

NOTE 1—Difficulty in achieving or maintaining intake manifold pressure or intake manifold temperature, or both, may be indicative of insufficient or excessive restriction.

6.2.3 Charge Air Cooler—In addition to the Caterpillar supplied charge air cooler which is engine mounted, use another cooler to simulate the air-to-air charge air cooler used in most field applications. A Modine (P/N 1A012865) cooler has been found suitable for this use. See A2.1 for instructions on obtaining this cooler. Alternatively, other charge air coolers may be used with the following limitations: (1) the cooler shall provide sufficient cooling capacity to control inlet manifold temperatures in the range specified elsewhere in this test method; (2) the boost air pressure drop across the cooler not exceed 15 kPa; and (3) the cooler is equipped with a drain system to remove condensate continuously from the boost air cooler outlet side. Remove the coolant diverter valve diaphragm for the Caterpillar supplied charge air cooler.

6.2.4 Exhaust System—Install the exhaust tube, see Fig. A4.7, at the discharge flange of the turbocharger turbine housing. The piping downstream of the exhaust tube is required, but not specified. Provide a method to control exhaust pressure.

6.2.5 Fuel System—The fuel supply and filtration system is not specified. See Fig. X1.2 for a typical configuration.

Determine the fuel consumption rate by measuring the rate of fresh fuel flowing into the day tank. Provide a method to control fuel temperature. Return the excess fuel from the engine into the day tank.

6.2.6 Coolant System—The system configuration is not specified. See Fig. X1.3 showing a typical configuration consisting of a non-ferrous core heat exchanger, a reservoir (expansion tank) and a temperature control valve. Pressurize the system by regulating air pressure at the top of the expansion tank. Ensure the system has a sight glass to detect air entrapment.

6.2.6.1 System volume is not specified. Avoid a very large volume as it may increase the time required for the engine coolant to reach operating temperatures.

6.2.7 Pressurized Oil Fill System—The oil fill system is not specified. A typical system includes an electric pump, a 50 L reservoir, and a transfer hose. Fig. A4.24 shows the location of the pressurized oil fill system.

6.2.8 External Oil System—Configure the oil system according to Fig. A5.1. The capacity of the oil reservoir is (10 to 13) L. Ensure that the oil return is drawn from the bottom of the oil reservoir Fig. A4.9. Use Viking Pump Model No. SG053514. Locate the external oil pumps at an elevation that is below the pump supply fitting on the oil pan. The nominal oil pump motor speed is 1725 rpm. Figs. A4.1-A4.4 show the pump supply and return port locations.

6.2.8.1 Oil Sample Valve Location—Locate the oil sample valve on the return line from the external oil system to the engine, and as close as possible to the return pump see Fig. A4.9 and Fig. A5.1.

6.2.8.2 Unacceptable Oil System Materials—Do not use brass or copper fittings because they can adversely influence oil wear metal analyses in the external oil system.

6.2.9 Crankcase Aspiration—Vent the blowby gas at the blowby filter housing located at the left front side of the cylinder head cover (Fig. A4.10). Use crankcase breather P/N 9Y-4357. Use breather spacer P/N 221-3934 or equivalent 20 mm thick plate with a fully open center. Use a P/N 9Y-1758 gasket on each side of the spacer.

6.2.10 Blowby Rate—See the general configuration of this system in Fig. A4.10. The minimum internal volume of the blowby canister is 26.5 L. The inside diameter of the pipe connecting the breather outlet to the blowby canister is 32 mm. Incline the pipe downward to the canister. The hose connecting the blowby canister to the flow rate measuring device is not specified but shall match closely to the inlet of the device. The flow rate measurement device is not specified. The J-TEC Associates, Inc. Model No. YF563C⁷ does give satisfactory results under the conditions specified in this test method.

6.3 System Time Responses—The maximum allowable system time responses are shown in Table 1. Determine system

⁷ The sole source of supply of the apparatus known to the committee at this time is J-TEC Associates, Inc., 5005 Blairs Forest Lane NE, Suite L, Cedar Rapids, IA 52402, www.j-tecassociates.com. If you are aware of alternative suppliers, please provide this information to ASTM International Headquarters. Your comments will receive careful consideration at a meeting of the responsible technical committee,¹ which you may attend.

⁶ Trademark of Caterpillar Inc., 100 North East Adams St., Peoria, IL 61629.

TABLE 1 Maximum Allowable System Time Responses

Measurement	Time Response
Speed	2.0 s
Temperature	3.0 s
Pressure	3.0 s
Flow	45.0 s

time responses in accordance with the Data Acquisition and Control Automation II (DACA II) Task Force Report.⁵

6.4 *Oil Sample Containers*—Preferably use high-density polyethylene containers for oil samples. (**Warning**—Avoid using glass containers which may break and cause injury or exposure to hazardous materials.)

7. Engine Liquids and Cleaning Solvent

7.1 *Test Oil*—Approximately 150 L of test oil is required to complete the test.

7.2 *Test Fuel*—Approximately 45 000 L of Chevron Philips PC-10 ultra low sulfur diesel fuel⁸ is required to complete the test. Fuel property tolerances are shown in **Annex A6**.

7.3 *Engine Coolant*—Prepare the engine coolant by mixing 50 % volume of mineral-free water with 50 % volume of Caterpillar brand coolant concentrate (As an option, pre-mixed coolant is available and may be used directly).

7.3.1 **Table 2** shows Caterpillar part numbers for several sized containers of concentrate or premixed coolant.

7.3.2 The mineral-free water shall have a mineral content not exceeding 34.4 mg/kg of total dissolved solids.

7.3.3 The coolant mixture may be used for 6 test starts or up to 3400 h. The mixture shall remain at a 50/50 ratio during the course of the test. Verify by using either Caterpillar testers 5P3514 or 5P0957 or an equivalent tester. Keep the coolant mixture free from contamination.

7.3.4 Keep the total solids below 5000 mg/kg.

7.3.5 Maintain a correct additive level. Verify by checking the coolant using Caterpillar test kit P/N 8T5296.

7.4 *Solvents and Cleaners Required*: (**Warning**—Use adequate safety precautions with all solvents and cleaners.)

7.4.1 *Solvent*—Use mineral spirits meeting Specification **D235**, Type II, Class C requirements for aromatic content (0 to 2 % by vol), flash point (61 °C, min), and color (not darker than +25 on Saybolt Scale or 25 on Pt-Co Scale). Obtain a Certificate of Analysis for each batch of solvent from the supplier. (**Warning**—Combustible. Health Hazard.)

7.4.2 *Pentane*—Used for rinsing and cleaning components before measurement. (**Warning**—Flammable. Health hazard.)

7.4.3 *Degreasing Solvent*—EnSolv⁹, a proprietary *n*-propyl bromide based solvent that can be used for cleaning the second rings. (**Warning**—Health hazard.)

⁸ The sole source of supply of the apparatus known to the committee at this time is Chevron Phillips Chemical Company LP, 10001 Six Pines Drive, Suite 4036B, The Woodlands, TX 77387-4910, www.cpchem.com. If you are aware of alternative suppliers, please provide this information to ASTM International Headquarters. Your comments will receive careful consideration at a meeting of the responsible technical committee,¹ which you may attend.

⁹ EnSolv is a registered trademark of and is available from Enviro Tech International, Inc., 2525 West LeMoyné Ave., Melrose Park, IL 60160, http://www.ensolv.com.

TABLE 2 Cat ELC^A Coolant Concentrate and Premix 50/50 Options

Container Size	3.8 L	19 L	208 L	Tote, ^B 275 g
Concentrate P/N	119-5150	...	136-3707	...
Premixed 50/50 P/N	101-2844	129-2151	101-2845	222-1534

^A Trademark of Caterpillar Inc., 100 North East Adams St., Peoria, IL 61629.

^B A small container.

8. Preparation of Apparatus

8.1 Cleaning of Parts:

8.1.1 *General*—Preparation of test engine components specific to the Caterpillar C13 test are indicated in this section. Use the Caterpillar Service Manual Form SEN R 9700¹⁰ (**Annex A7**) for the preparation of other components (except for the piston second ring—see **8.2.7**). Take precautions to protect rusting of iron components. Use of an engine parts washer followed by a solvent wash is permitted.

8.1.2 *Engine Block*—Disassemble the engine, including removal of the crankshaft, camshaft, piston cooling tubes, oil pump, and oil gallery plugs. Thoroughly clean the surfaces and oil passages (galleries). Use a nylon brush to clean the oil passages. Removal of camshaft bearings is optional.

8.1.3 *Cylinder Head, Intake System and Duct*—Disassemble and clean these components before each test. Scrub with a nylon brush and solvent. Use of an engine parts washer followed by a solvent wash is permitted.

8.1.4 *Rocker Cover and Oil Pan*—Clean the Rocker Cover and Oil Pan. Use a nylon brush, as necessary, to remove deposits.

8.1.5 *External Oil System*—Flush the internal surfaces of the oil lines and the external reservoir with solvent. Repeat until the solvent drains cleanly. Flush the solvent through the oil pumps until the solvent drains cleanly, then air dry.

8.1.6 *High Pressure Turbocharger*—Carefully remove the turbine housing from the turbocharger and clean the waste-gate valve with solvent and a soft wire brush.

8.1.7 *Cam Follower Assembly*—Take the cam follower assembly apart and inspect the bushings and pins. Replace the parts as necessary.

8.2 Engine Assembly:

8.2.1 *General*—Except as noted in this section, use the procedures described in the Caterpillar Service Manual Form SEN R 9700¹⁰ (**Annex A7**). Assemble the engine with the components shown in the Engine Build Parts List (**Annex A3**).

8.2.2 *Parts Reuse and Replacement*—Reuse engine components, except as noted in **8.2.7**, and provided that they meet production tolerances as described in the Caterpillar Service Manual.

8.2.3 *Build-up Oils*—For the head, main caps, and rod bolts, use Exxon Mobil 600N engine oil¹¹ as the build-up oil. For the rest of the engine build, use Mobil EF-411 engine oil¹¹ or test

¹⁰ Available from a Caterpillar parts distributor.

¹¹ The sole source of supply of the apparatus known to the committee at this time is ExxonMobil Corporation, 3225 Gallows Road, Fairfax, VA 22037, www.exxonmobil.com. If you are aware of alternative suppliers, please provide this information to ASTM International Headquarters. Your comments will receive careful consideration at a meeting of the responsible technical committee,¹ which you may attend.

oil to lubricate the parts. If test oil is used, the engine build is valid only for the respective test oil.

8.2.4 *Coolant Thermostat*—Lock the engine coolant thermostat open.

8.2.5 *Fuel Injectors*—Use P/N 239-4908 fuel injectors. If fuel injectors are reused, exercise caution to avoid mechanical damage to or contamination of the nozzles. Dedicate the injectors to a particular cylinder. Install the injectors according to the method described in Caterpillar Service Manual Form SENR9700 (Annex A7). Use Mobil EF-411 engine oil as the build-up oil for the injector o-rings.

8.2.6 *Piston Cooling Tubes*—Target the piston cooling tubes. Contact TMC for directions.

8.2.7 *New Parts*—The following new parts are included in the Engine Build Parts List. They are not reusable, except as noted in 10.3.3. Clean the parts prior to use. For piston second rings, cleaning with a solvent such as EnSolv and following with a pentane rinse has been shown to be effective. During a test, a replacement of any of the new parts listed below will invalidate the test.

8.2.7.1 Pistons.

8.2.7.2 Piston rings (top, second and oil).

8.2.7.3 Cylinder liners.

8.2.7.4 Valves (intake, exhaust).

8.2.7.5 Valve guides.

8.2.7.6 Valve seats.

8.2.7.7 Connecting rod bearings, main bearings and thrust plate.

8.3 *Operational Measurements:*

8.3.1 *Units and Formats*—See Annex A8.

8.3.2 *Instrumentation Calibration:*

8.3.2.1 *Fuel Consumption Rate Measurement*—Calibrate the fuel consumption rate measurement system before each reference oil test sequence and within six months after completion of the last successful calibration test. Temperature-compensate volumetric systems, and calibrate them against a standard mass flow device. The flowmeter on the test stand shall agree within 0.2 % of the calibration standard, that standard itself being calibrated against a national standard.

8.3.2.2 *Temperature Measurement Calibration*—Calibrate the temperature measurement systems before each reference oil test sequence and within six months after completion of the last successful calibration test. Each temperature measurement system shall agree within ± 0.5 °C of the laboratory calibration standard, that standard itself being calibrated against a national standard.

8.3.2.3 *Pressure Measurement Calibration*—Calibrate the pressure measurement systems before each reference oil test sequence and within six months after completion of the last successful calibration test. Confirm the calibration standard against a national standard.

8.3.3 *Temperature Measurement Locations:*

8.3.3.1 *General*—See Table A14.1. The measurement equipment is not specified. Install the sensors such that the tip is located midstream of the flow unless otherwise indicated. The accuracy and measurement of the temperature measure-

ment sensors and the complete measurement system shall follow the guidelines in ASTM Research Report RR:D02-1218.¹²

8.3.3.2 *Coolant Out Temperature*—Install the sensor in the fitting on the thermostat housing (Fig. A4.12).

8.3.3.3 *Coolant In Temperature*—Install the sensor on the right side of the coolant pump intake housing at the 1-in. NPT port (Fig. A4.13).

8.3.3.4 *Fuel In Temperature*—Install the sensor in the fuel pump inlet fitting (Fig. A4.15).

8.3.3.5 *Oil Gallery Temperature*—Install the sensor at the ¼ in. NPT female boss on the right rear of the engine (Fig. A4.14).

8.3.3.6 *Intake Air Temperature*—Install the sensor in the inlet air tube 127 mm upstream of the compressor connection (Fig. A4.6).

8.3.3.7 *Intake Manifold Temperature*—Install the sensor at the ⅛ in. NPT female boss on the outside radius of the inlet manifold elbow (Fig. A4.16).

8.3.3.8 *Exhaust Temperature*—Install the sensor in the exhaust tube (Fig. A4.7).

8.3.3.9 *Additional Temperatures*—It is permissible to measure any additional temperatures that may be useful for test operation or engine diagnostics.

NOTE 2—Additional exhaust sensor locations, at the exhaust ports and pre-turbine (front and rear), are recommended. The detection of changes in exhaust temperatures is an important diagnostic feature.

8.3.4 *Pressure Measurement Locations:*

8.3.4.1 *General*—The measurement equipment is not specified. Follow the guidelines in ASTM Research Report RR:D02-1218¹² for the accuracy and resolution of the pressure measurement sensors and the complete measurement system. If the laboratory has problems with condensation forming in the pressure lines, install a condensation trap at the lowest elevation of the tubing between the pressure measurement location and the final pressure sensor for crankcase pressure, intake air pressure, and exhaust pressure. Route the tubing to avoid intermediate loops or low spots before and after the condensation trap.

8.3.4.2 *Oil Gallery Pressure*—Measure the pressure at the ¼ in. NPT fitting on the right rear of the engine (Fig. A4.14).

8.3.4.3 *Oil Filter Inlet Pressure*—Measure the pressure at the plug located on the inlet side of the oil filter assembly (Fig. A4.8).

8.3.4.4 *Inlet Manifold Pressure*—Measure the pressure at the ¼ in. NPT port on the outside radius of the inlet manifold elbow (Fig. A4.16).

8.3.4.5 *Crankcase Pressure*—Measure the pressure by installing a bulkhead fitting in the valve cover, top-front (Fig. A4.11).

8.3.4.6 *Intake Air Pressure*—Measure the pressure at a wall tap on the intake air tube 153 mm upstream of the compressor connection (Fig. A4.6).

8.3.4.7 *Exhaust Pressure*—Measure the pressure on the exhaust tube (Fig. A4.7).

¹² Supporting data have been filed at ASTM International Headquarters and may be obtained by requesting Research Report RR:D02-1218.

8.3.4.8 *Fuel Pressure*—Measure the pressure at the fuel filter head (Fig. A4.25).

8.3.4.9 *Coolant Pressure*—Measure the pressure on top of the expansion tank (Fig. X1.3).

8.3.4.10 *Intercooler Delta Pressure*—Measure the pressure drop across the intercooler. Measure the intercooler inlet pressure at the elbow outlet of the CAT charge air cooler (Fig. A4.19). Use the intake manifold pressure (8.3.4.4) as the intercooler outlet pressure. The intercooler delta pressure is the difference between the intercooler outlet pressure and the intercooler inlet pressure.

8.3.4.11 *Additional Pressures*—It is permissible to measure any additional pressures that may be useful for test operation or engine diagnostics.

NOTE 3—See Fig. A4.19 and Fig. A4.20 for additional instrument placement information.

8.3.5 *Flow Rate Measurement Locations:*

8.3.5.1 *General*—The equipment for the blowby rate and fuel rate measurements is not specified. Follow the guidelines in ASTM Research Report RR:D02-1218¹² for the accuracy and resolution of the flow rate measurement system.

8.3.5.2 *Blowby*—The device used to measure the blowby flow rate is not specified. See 6.2.10 for blowby measurement system configuration details.

8.3.5.3 *Fuel Flow*—Determine the fuel consumption rate by measuring the fuel flowing to the day tank (Fig. X1.2).

8.3.5.4 *Coolant Flow*—Coolant flow rate measurement is not a test requirement, but may be useful for diagnostic purposes. The design and use of a coolant flow measuring system is optional.

8.3.6 *Humidity Measurement*—Measure intake air humidity anywhere in the air intake system between air conditioning and the turbo inlet.

9. Engine/Stand Calibration and Non-Reference Oil Tests

9.1 *General*—Calibrate the test stand by conducting a test with a blind reference oil.⁸ Submit the results to the TMC for determination of acceptance according to the Lubricant Test Monitoring System (LTMS).⁵

9.2 *New Laboratories and New Test Stands:*

9.2.1 *New Laboratory*—A new laboratory is any laboratory that has never previously calibrated a test stand by this test method.

9.2.2 *New Test Stand*—A new test stand is a test cell and support hardware that has never previously been calibrated by this test method. Perform a calibration (9.2.3) to introduce a new test stand.

9.2.3 *New Test Stand Calibration*—Calibrate a new test stand in accordance with the LTMS.⁵

9.3 *Stand Calibration Period*—The calibration period is 12 operationally valid (Annex A11) non-reference oil tests or 12 months, whichever comes first, from the EOT date of the last acceptable reference oil test.

9.4 *Stand Modification and Calibration Status*—Stand calibration status will be invalidated by conducting any non-standard test or modification of the test and control systems, or both. A non-standard test is any test conducted under a

modified procedure, non-procedural hardware, controller set-point modifications, or any combination thereof. If changes are contemplated, contact the TMC beforehand to ascertain the effect on the calibration status.

9.5 *Test Numbering System:*

9.5.1 *General*—The test number has two parts, X and Y. X represents the test stand number and Y represents the sequential test stand run number. For example 27-15 indicates test stand number 27 and test stand run number 15. The test stand run number, Y will increase sequentially by one for each test start (reference oil or non-reference oil). A letter suffix may also be necessary (see 9.5.2).

9.5.2 *Reference Oil Tests*—A reference oil test conducted subsequent to an unacceptable reference oil test shall include a letter suffix after Y. The letter suffix shall begin with A and incremented alphabetically until acceptable reference oil test is completed. For example, if two consecutive unacceptable reference oil tests were conducted and the first number was 27-15, the second test number would be 27-16A. A third calibration attempt would have the test number 27-17B. If the third test were acceptable, then 27-17B would identify the reference oil test in the test report.

9.5.3 *Non-Reference Oil Tests*—Add no letter suffix to Y for aborted or operationally invalid non-reference oil tests.

9.6 *Reference Oil Test Acceptance*—Determine reference oil test acceptance in accordance with the LTMS.⁵

9.7 *Reference Oil Accountability:*

9.7.1 Keep full accounts of the identification and quantities of all reference oils used. With the exception of the oil analyses required in 11.3, perform no chemical or physical analyses on reference oils without written permission from the TMC. In such an event, include the written confirmation and the analytical results generated in the reference oil test report.

9.7.2 Retain used reference oil samples for 90 days from the EOT date.

9.8 *Non-Reference Oil Tests: Last Start Date*—When running a non-reference oil test during the calibration period; crank the engine prior to the expiration of the calibration period (9.3).

9.9 *Donated Reference Oil Test Programs*—The surveillance panel is charged with maintaining effective reference oil test severity and precision monitoring. During times of new parts introductions, new or re-blended reference oil additions, and procedural revisions, it may be necessary to evaluate the possible effects on severity and precision levels. The surveillance panel may choose to conduct a program of donated reference oil tests in those laboratories participating in the monitoring system to quantify the effect of a particular change on severity and precision. Typically the surveillance panel requests its panel members to volunteer enough reference oil test results to create a robust data set. Broad laboratory participation is needed to provide a representative sampling of the industry. To ensure the quality of the data obtained, donated tests are conducted on calibrated test stands. The surveillance panel shall arrange an appropriate number of donated tests and ensure completion of the test program in a timely manner.

TABLE 3 Break-in Conditions

Parameter	Unit	Stage				
		1	2	3	4	5
Stage Length	min	5	5	10	20	20
Speed	rpm	1100	1200	1600	1800	1800 ± 5
Fuel Flow	g/min	Record	Record	Record	Record	1200 ± 6
Torque	N·m	0	480	1000	1160	Record
Coolant Out Temperature ^A	°C	88	88	88	88	88 ± 2
Oil Gallery Temperature ^A	°C	Record	Record	Record	Record	98 ± 2
Intake Manifold Temperature ^A	°C	40	40	40	40	40 ± 2

^A This is the control set-point. It can require up to 30 min of operation to achieve.

9.10 Adjustment to Reference Oil Calibration Periods:

9.10.1 *Procedural Deviations*—On occasions when a laboratory becomes aware of a significant deviation from the test method, such as might arise during an in-house review or a TMC inspection, the laboratory and the TMC shall agree on an appropriate course of action to remedy the deviation. This action may include the shortening of existing reference oil calibration periods.

9.10.2 *Parts and Fuel Shortages*—Under special circumstances, such as industry-wide parts or fuel shortages, the surveillance panel may direct the TMC to extend the time intervals between reference oil tests. These extensions shall not exceed one regular calibration period.

9.10.3 *Reference Oil Test Data Flow*—To ensure continuous severity and precision monitoring, calibration tests are conducted periodically throughout the year. There may be occasions when laboratories conduct a large portion of calibration tests in a short period of time. This could result in an unacceptably large time frame when very few calibration tests are conducted. The TMC can shorten or extend calibration periods as needed to provide a consistent flow of reference oil test data. Adjustments to calibration periods are made such that laboratories incur no net loss (or gain) in calibration status.

9.10.4 *Special Use of the Reference Oil Calibration System*—The surveillance panel has the option to use the reference oil system to evaluate changes that have potential impact on test severity and precision. This option is only taken when a program of donated tests is not feasible. The surveillance panel and the TMC shall develop a detailed plan for the test program. This plan requires all reference oil tests in the program to be completed as close to the same time as possible, so that no laboratory or stand calibration is left in an excessively long pending status. In order to obtain the integrity of the reference oil monitoring system each reference oil test is conducted so as to be interpretable for stand calibration. To facilitate the required test scheduling, the surveillance panel may direct the TMC to lengthen and shorten reference oil calibration periods within laboratories such that the laboratories incur no net loss (or gain) in calibration status.

10. Procedure

10.1 *Engine Installation and Stand Connections*—Install the test engine on the stand and connect the engine to the stand support equipment.

10.2 *Coolant System Fill*—Fill the cooling system with pre-diluted Caterpillar Extended Life Coolant (see 7.3 for part

numbers and available container sizes). The coolant for non-reference oil tests may be reused provided the level of inhibitors is within specification requirements. Use new coolant for each reference oil test. Pressurize the cooling system as required by the specification and check for leaks prior to adding the test oil.

10.3 Oil Fill for Break-in and Test:

10.3.1 Install a new Caterpillar 1R-1808 oil filter.¹⁰

10.3.2 Use the pressurized oil fill system (6.2.7) to charge the engine with 32.8 kg ± 0.2 kg of test oil at the location shown in Fig. A4.8.

10.3.3 *Engine Build Committed*—After the test oil has been introduced into the engine, the engine build and test number are valid only for the respective test. However, if the engine has not been cranked (whereby the test parts have not been subjected to wear or injected fuel, or both), then the new parts may be used again. Disassemble and clean the engine according to 8.1.

10.4 *Fuel Samples*—Take a minimum 60 mL fuel sample at the start of the test and at EOT.

10.5 *Engine Warm-up and Break-in*—Prior to firing the engine, ensure that the oil temperature is at least 15 °C. The oil gallery startup pressure shall be at least 350 kPa. Perform a timing calibration for the engine control software and timing sensor components as specified in Caterpillar Service Manual Form SEN R 9700 (Annex A7). If the coolant temperature is less than 18 °C, the engine will operate under cold mode thereby preventing the timing calibration procedure from being performed. When this happens, start the engine and allow it to idle until the speed drops from 1000 rpm to 600 rpm, signaling that the coolant temperature has exceeded 18 °C. After the timing calibration is completed, continue break-in conditions as shown in Table 3. Turn on the external oil weigh system pumps at the beginning of stage 2.

10.5.1 *Shutdown During Break-in*—If a shutdown occurs during the break-in, resume the break-in from the point at which the shutdown occurred. Such an occurrence is described in Other Comments on the appropriate form.

NOTE 4—Use the break-in as an opportunity to confirm engine performance and to make repairs prior to the start of the 500 h test procedure.

10.5.2 *Valve Lash Adjustment*—At the completion of the 60 min break-in, shut the engine down, using the normal shutdown procedure as shown in 10.7.1. Allow the engine to cool for a minimum of 4 h and then perform the valve lash

TABLE 4 Warm-up Conditions

Parameter	Unit	Stage				
		1	2	3	4	5
Stage Length	min	2.5	2.5	5	10	10
Speed	rpm	1100	1200	1600	1800	1800
Fuel Flow	g/min	Record	Record	Record	Record	1200
Torque	N·m	0	480	1000	1160	Record
Coolant Out Temperature ^A	°C	88	88	88	88	88
Oil Gallery Temperature ^A	°C	Record	Record	Record	Record	98 ± 2
Intake Manifold Temperature ^A	°C	40	40	40	40	40

^A This is the control set-point. It can require up to 30 min of operation to achieve.

adjustment as described in Caterpillar Service Manual Form SEN R 9700 (**Annex A7**) At the same time, do the inlet valve actuator valve adjustment.

10.6 *Warm-up*—Start the engine, perform the warm-up (**Table 4**), and proceed directly to the test conditions (**Table 5**). At the engine start, the oil gallery temperature shall be at least 15 °C. The start-up oil gallery pressure shall be at least 350 kPa.

10.7 *Shutdown and Maintenance*—The test may be shut down at the discretion of the laboratory to perform repairs. However, the intent of this test method is to conduct the 500 h test procedure without shutdowns.

10.7.1 *Normal Shutdown*—A normal shutdown is accomplished by ramping in 30 s from test conditions to stage 2 of the warm-up conditions (**Table 4**), running for 5 min at stage 2, ramping in 30 s to stage 1, running for 5 min at stage 1, and then stopping the engine.

10.7.2 *Emergency Shutdown*—An emergency shutdown occurs when the normal shutdown cannot be performed, such as under an alarm condition. Such an occurrence is described in Other Comments of the appropriate form.

10.7.3 *Maintenance*—Engine components or stand support equipment, or both may be repaired or replaced at the discretion of the laboratory, and in accordance with this test method.

10.7.3.1 *Deposits Around Turbo-charger Waste-gate Shaft*—Deposits tend to build up with time and thereby prevent free movement of the turbo-charger waste-gate shaft. When the engine is shut down for maintenance at any time, free the shaft mechanically. Otherwise follow such a procedure if the intake manifold pressure (IMP) falls outside of the 275 kPa to 285 kPa range and does not respond to normal adjustment techniques.

10.7.4 *Downtime*—The limit for total downtime and number of shutdowns is not specified. Record all shutdowns, pertinent actions, and total downtime during the 500 h test procedure on the appropriate form.

10.8 500 h Test Procedure:

10.8.1 Start the test procedure following break-in, normal shutdown, valve lash adjustment and warm-up, as described in **10.2** through **10.7**.

10.8.2 *New Oil Sample*—Take a 120 mL sample of the fresh oil from the original oil container.

10.8.3 *Operating Conditions*—After warm-up proceed directly to the 500 h Test Schedule (**Table 5**).

10.8.4 *Test Timer*—The 500 h test timer starts when all controlled parameters shown in **Table 5** are all within speci-

TABLE 5 500 h Test, Schedule of Conditions

Parameter	Unit	Requirement
Test Length	h	500
Speed	rpm	1800
Power	kW	Record
Torque (Typical) ^A	N·m	1760
Fuel Flow	g/min	1200
Intake Manifold Temperature	°C	40
Blowby Flow	L/min	Record
Coolant Out Temperature	°C	88
Coolant In Temperature	°C	Record
Coolant Delta Temperature	°C	Record
Fuel In Temperature	°C	40
Oil Gallery Temperature	°C	98
Inlet Air Temperature	°C	25
Intake Manifold Pressure	kPa, Gauge	275-285
Exhaust Temperature	°C	Record
Fuel Pressure	kPa	Record
Oil Gallery Pressure	kPa	Record
Oil Filter Delta Pressure	kPa	Record
Coolant System Pressure ^B	kPa	99-107
Exhaust Restriction	kPa	6
Crankcase Pressure	kPa	Record
Inlet Air Pressure	kPa, Absolute	93.0 ± 1.5
Intercooler Delta Pressure	kPa	15 max
Humidity	g/kg	Record

^A At standard atmospheric temperature and pressure.

^B As measured at the top of the expansion tank.

cation requirements. If a shutdown occurs, stop the test timer immediately at the initiation of the shutdown. The test timer shall resume when the test has been returned to the test operation schedule and all controlled parameters are within specification requirements.

10.8.5 *Operational Data Acquisition*—Record all operational parameters shown in **Table 5** with automated data acquisition at a minimum frequency of once every 6 min. Recorded values shall have minimum resolution in accordance with **Annex A8**.

10.8.5.1 Report the operational data on the appropriate form.

10.8.6 *Oil Purge Sample and Addition*—Perform a purge and take an oil sample at 4 h. Do not add fresh oil at the 4 h point. Perform a purge, take an oil sample and make an oil addition at the end of each 50 h period. Add new oil and purge sample to the external oil system reservoir.

10.8.6.1 *Do not shut down the engine for oil sampling and oil addition.*

10.8.6.2 *Full Mass*—Record the oil mass indicated by the external oil system at the completion of the fourth test hour and before removal of the 150 mL purge and the 120 mL oil sample. This mass is the *full mass*.

10.8.6.3 At the end of each 50 h period, record the oil mass indicated by the external oil system and take a 150 mL oil purge sample followed by a 120 mL oil analysis sample. Identify the oil sample container with the test number, oil code, date and test hour.

10.8.6.4 Add new oil equivalent to *full mass* minus the external oil system mass (as determined in step 10.8.6.3), plus the 120 mL sample. Add back the purge sample taken in 10.8.6.3. At 500 h make no oil additions.

10.8.6.5 *Emergency Oil Additions*—If the external oil weigh system retained mass falls to 0.5 kg or less at any time before the next scheduled 50 h oil add point, calculate, based on the immediately preceding oil consumption history, the amount of oil required to maintain the external oil weigh system mass above 0.5 kg until the next scheduled oil addition. Add this amount of fresh oil to the system.

10.9 End of Test (EOT):

10.9.1 After completing the test procedure, perform a normal shutdown. Release the cooling system pressure and drain the coolant. Disconnect the test stand support equipment. (**Warning**—The coolant and oil may be very hot. The installation of a valve to safely vent the cooling system pressure is recommended.)

10.9.2 Drain the oil from the engine and the external oil system.

10.9.3 *Engine Disassembly*—Disassemble the engine and remove the following components for ratings and measurements.

10.9.3.1 Pistons.

10.9.3.2 Piston rings. *Do not remove rings from pistons until ring sticking has been rated.*

11. Calculations, Ratings, Test Validity, and Test Results

11.1 *Piston Ratings*—Rate the pistons according to ASTM Deposit Rating Manual 20 at the locations specified using the special instructions noted in Annex A9. For deposit weighting factors, use those described in the Caterpillar 1P test method, Test Method D6681. For the varnish ratings, use the Manual 20 expanded varnish scale and convert to demerits.

11.1.1 *Rate the pistons for ring sticking prior to the removal of the rings from the pistons for cleaning and rating.*

11.2 Ring Cleaning and Rating:

11.2.1 For ring cleaning and rating, Use the procedure described in C13 Ring Cleaning and Rating Procedure available from the TMC.

11.3 *Oil Analyses*—Analyze the oil samples according to the schedule and methods shown in Annex A11.

11.4 *Oil Consumption*—Using the 6 min oil mass measurements, determine the oil consumption in grams per hour by performing linear regression on the data for each of the ten 50 h periods. The oil consumption for a 50 h period is the slope of the regression line for that same period.

11.4.1 Exclude the first 4 h of oil mass data following any shutdowns or oil additions from the regression to account for the stabilization of the oil scale.

11.4.2 If any shutdowns occur during a 50 h period, the result for that 50 h period shall be the weighted average of all

the regression slopes that apply to that period. The weighting of a regression slope is the length of run time associated with it. For example, a test experiences a shutdown at test hour 20. The slope for the first period of 16 h (hour 4 to 20) is 14.6 g/h, and the slope for the second period of 26 h (hour 24 to 50) is 28.6 g/h. The weighted average is calculated as follows:

$$\text{OC-weighted average} = \frac{[(14.6 \text{ g/h})(16 \text{ h}) + (28.6 \text{ g/h})(26 \text{ h})]}{(16 \text{ h} + 26 \text{ h})} \quad (1)$$

11.5 *Fuel Analyses*—Report the analytical data provided by the fuel supplier on the appropriate form. Report the analytical data of the final batch if more than one fuel batch was used.

11.5.1 *Additional Analyses*—Perform the following analyses on the 60 mL new and EOT fuel samples.

11.5.1.1 API Gravity at 15.6 °C, Test Method D4052.

11.5.1.2 Total Sulfur, mass percent, Test Method D5453 (D2622 or D4294 may be substituted).

11.6 *Assessment of Operational Validity*—Determine operational validity according to Annex A11.

11.7 *Test Results*—The specified reference oil test results are: (1) average top groove carbon (demerits), (2) average top land carbon (demerits), (3) average second ring top carbon (demerits), and (4) delta oil consumption (grams per hour). The non-reference oil test specified result is the C13 Merit Rating as shown in Annex A14.

11.7.1 *Three Average Carbon (Demerits), Calculation and Reporting*—Screen each carbon (demerits) data set (top groove carbon, top land carbon, and second ring top carbon) for outliers according to Annex A13. Calculate the average carbon (demerits) for each set, excluding any outliers, and report the data on the appropriate forms.

11.7.2 *Delta Oil Consumption*—Calculate the delta oil consumption according to the following:

$$\text{Delta Oil Consumption (g/h)} \quad (2)$$

$$= [(OC450 + OC500)/2] - [(OC100 + OC150)/2]$$

where:

OC100 = the average oil consumption (g/h) for the 50 h period from 50 h to 100 h as determined in 11.4,

OC150 = the average oil consumption (g/h) for the 50 h period from 100 h to 150 h as determined in 11.4,

OC450 = the average oil consumption (g/h) for the 50 h period from 400 h to 450 h as determined in 11.4, and

OC500 = the average oil consumption (g/h) for the 50 h period from 450 h to 500 h as determined in 11.4.

12. Test Report

12.1 Reporting Reference Oil Test Results:

12.1.1 For reference oil tests, the standardized report form set and data dictionary for reporting test results and for summarizing operational data are required. Report forms and the Data Dictionary are available from the TMC. Fill out the report forms according to the formats shown in the Data Dictionary. When transmitting data electronically, a Header Data Dictionary shall precede the Data Dictionary. The latest

TABLE 6 Test Precision

Test Result	Measured Units	
	Intermediate Precision, (i.p.)	Reproducibility, (R)
Average Top Groove Carbon, Demerits	20.2	19.6
Average Top Land Carbon, Demerits	12.9	15.7
Oil Consumption Delta, g/h (transformed units) ^A	2.340	2.845
Average Second Ring Top Carbon, Demerits (transformed units) ^B	1.691	1.658

^A This parameter is transformed using a square root. When comparing two test results on this parameter, first apply this transformation to each test result. Compare the absolute difference between the transformed results with the appropriate (intermediate or reproducibility) precision limit.

^B This parameter is transformed using a natural log. When comparing two test results on this parameter, first apply this transformation to each test result. Compare the absolute difference between the transformed results with the appropriate (intermediate or reproducibility) precision limit.

version of this Header Data Dictionary can be obtained from the TMC either by ftp (internet) or by calling the Test Engineer responsible for this particular test. Round the data in accordance with Practice E29.

12.1.2 When reporting reference oil test results, transmit the test data electronically by utilizing the ASTM Data Communications Committee Test Report Transmission Model (see Section 2—Flat File Transmission Format)⁵ which is available from the TMC. Transmit the data within five working days of test completion. Mail a copy of the final test report within 30 days of test completion to TMC.⁵

12.2 *Deviations from Test Operational Limits*—Report all deviations from specified test operational limits on the appropriate form under Other Comments.

13. Precision and Bias

13.1 *Precision*—Precision (intermediate precision and reproducibility) is based on operationally valid calibration test results monitored by the TMC.

13.1.1 *Intermediate Precision:*

13.1.1.1 *Intermediate Precision Conditions*—Conditions where test results are obtained with the same method and the same test oil, with changing conditions such as operators, measuring equipment, test stands, test engines and time.

NOTE 5—*Intermediate precision* is the appropriate term for this test method rather than *repeatability*, which defines more vigorous within-laboratory conditions.

13.1.1.2 *Intermediate Precision Limit (i.p.)*—The difference between two results obtained under intermediate precision conditions that would in the long run, in the normal and correct

conduct of the test method, exceed the values shown in Table 6 in only one case in twenty. When only a single result is available, the Intermediate Precision Limit can be used to calculate a range (test result \pm Intermediate Precision Limit) outside of which a test result would be expected to fall about one time in twenty.

13.1.2 *Reproducibility:*

13.1.2.1 *Reproducibility Conditions*—Conditions where test results are obtained with the same test method using the same test oil in different laboratories with different operators using different equipment.

13.1.2.2 *Reproducibility Limit (R)*—The difference between two results obtained under reproducibility conditions that would, in the long run, in the normal and correct conduct of the test method, exceed the values in Table 6 in only one case in twenty. When only a single test result is available, the Reproducibility Limit can be used to calculate a range (test result \pm Reproducibility Limit) outside of which a second test result would be expected to fall about one time in twenty.

13.1.3 The test precision for this test method as of July 2015 is shown in Table 6.

13.2 *Bias*—Bias is determined by applying a defined statistical technique to calibration test results. When a significant bias is determined, apply a severity adjustment to the non-reference oil test result.

14. Keywords

14.1 2nd ring top carbon; Caterpillar C13; diesel engine oil; lubricants; oil consumption; piston deposits; piston ring sticking; top groove carbon; top land carbon

ANNEXES

(Mandatory Information)

A1. SAFETY PRECAUTIONS

Annex A1
Annex A2
Annex A3
Annex A4
Annex A5
Annex A6
Annex A7
Annex A8
Annex A9
Annex A10
Annex A11
Annex A12
Annex A13
Annex A14

Safety Precautions
Intake Air Aftercooler
Engine Build Parts Kit
Sensor Locations and Special Hardware
External Oil System
Fuel Specification
Caterpillar Service Publications
Specified Units and Formats
Piston Ring Locations
Oil Analyses
Determination of Operational Validity
Oil Temperature Control System
C13 Outlier Screening Methods
C13 Merit Rating Calculation

A1.1 The operation of engine tests may expose personnel and facilities to safety hazards. Personnel trained and experienced with engine testing shall perform the design, installation and operation of the test stands.

A1.2 Install guards (shields) around all external moving, hot, or cold components. Design the guard to contain the energy level of a rotating component should the component break free. Properly route fuel, oil and electrical wiring, and guard, ground and keep in good order.

A1.3 Keep the test stand free of oil and fuel spills and tripping hazards. Do not permit containers of oil or fuel, or both, to accumulate in the testing area. Fire fighting equipment shall be immediately accessible. Observe normal precautions whenever using combustible solvents for cleaning purposes.

A1.4 Safety masks, glasses or hearing protection, or a combination thereof, shall be worn by personnel working on the test stand. Do not wear loose or flowing clothing, including

neither long hair nor other accessory to dress, near rotating equipment. Caution personnel against working alongside the engine and driveline while the engine is running.

A1.5 Interlocks shall automatically shut down the engine when an anomaly in any of the following occurs: engine or dynamometer coolant temperature, engine oil pressure, dynamometer field current, engine speed, exhaust temperature, excessive vibration, or when the fire protection system is activated. The interlock shall include a method to cut off the fuel supply to the engine at the injector pipe (including the return line). A remote fuel cutoff station (external to the test stand) is recommended.

A1.6 Employ other safety precautions as required by regulations.

A2. INTAKE AIR AFTERCOOLER

A2.1 Obtain the Modine air aftercooler from a Mack Truck dealer. Order the aftercooler using part number 5424 03 928 031. This is a non-stocked part in the Mack Parts Distribution System and appears as an invalid part number. Instruct the

dealer to expedite the aftercooler on a Ship Direct purchase order. The aftercooler will be shipped directly from Modine, bypassing the normal Mack Parts Distribution System.

A3. ENGINE AND ENGINE BUILD PARTS KIT

A3.1 Obtain the Caterpillar C13 Engine Arrangement Number 244-4803 or 249-8361 by contacting the Caterpillar Oil Test Engine Representative. Current contact information is maintained at the ASTM Test Monitoring Center (TMC).

A3.3 A listing of non-critical engine build parts is available from the TMC. The list shows current part numbers. The parts may be obtained directly from a Caterpillar dealer.

A3.2 Critical parts are shown in [Table A3.1](#).

A3.2.1 Obtain critical parts by contacting the Caterpillar Oil Test Engine Representative. Current contact information is maintained at the TMC.

TABLE A3.1 Engine Build Parts (Critical)

Item	Part Number
Piston	1Y-4106
Liner – Cylinder	1Y-4107
Ring – Top	1Y-4108
Ring – Intermediate	1Y-4109
Ring – Oil	1Y-4110
Valve – Intake	224-3028
Valve – Exhaust	224-3030
Valve Guide	259-2186
Valve Seat – Intake	224-2410
Valve Seat – Exhaust	224-1270
Connecting Rod Bearing	116-1089
Main Bearing	211-0587 and 211-0588
Thrust Plate	1Y4118 or 116-1107

A4. SENSORS LOCATION AND SPECIAL HARDWARE

A4.1 See [Table A4.1](#) and [Figs. A4.1-A4.25](#).

TABLE A4.1 Temperature, Pressure and Flow Measurements Locations (Including Optional Measurements)

Description	Instrument	Location
Total Coolant In	Temperature	Coolant Pump Inlet Pipe
Engine Coolant In	Temperature	Coolant Pump Suction
Primary Turbo Compressor Out	Temperature	Cast Aluminum Pipe between Turbos
Inlet Manifold	Temperature	Inlet Manifold Elbow
Oil Gallery	Temperature	Side of Block
Coolant Out	Temperature	Thermostat Housing
Secondary Turbo Turbine Out	Temperature	Facility Piping—Locate 305 mm after flange/bend and 102 mm before transition
Secondary Turbo Compressor Out	Temperature	Facility Piping
Oil Filter In	Temperature	Oil Filter Housing
Oil Filter Out	Temperature	Oil Filter Housing
Primary Turbo Drain	Temperature	Turbo Drain
Secondary Turbo Drain	Temperature	Turbo Drain
Oil Sump	Temperature	Oil Pump Plug below oil level
Cylinders 1, 2 and 3	Temperature	Exhaust Manifold
Cylinder 4	Temperature	Not accessible
Cylinders 5 and 6	Temperature	Exhaust Manifold
Exhaust Manifold Front	Temperature	Exhaust Manifold
Exhaust Manifold Rear	Temperature	Exhaust Manifold
Fuel at Pump	Temperature	Transfer Pump
Oil Regulator	Temperature	Oil Filter Housing
Charge Air Cooler Water In	Temperature	Facility Piping
Total Coolant In	Pressure	Coolant Pump Inlet Pipe
Secondary Turbo Compressor Out	Pressure	Facility Piping
Inlet Manifold	Pressure	Inlet Manifold Elbow
Oil Gallery	Pressure	Side of Block
Secondary Turbo Turbine Out	Pressure	Facility Piping—Locate 305 mm after flange/bend and 102 mm before transition
Secondary Turbo Compressor Out	Pressure	Facility Piping
Crankcase	Pressure	Valve Cover—Use a bulkhead with seal fitting
Fuel at Filter Housing	Pressure	Fuel Filter Housing
Oil Filter In	Pressure	Filter Housing
Oil Filter Out	Pressure	Oil Filter Housing
Exhaust Manifold Front	Pressure	Exhaust Manifold
Exhaust Manifold Rear	Pressure	Exhaust Manifold
Fuel at Pump	Pressure	Transfer Pump
Coolant	Flow	Facility Piping
Fuel	Flow	Remote Measurement
Blowby	Flow	Remote Measurement

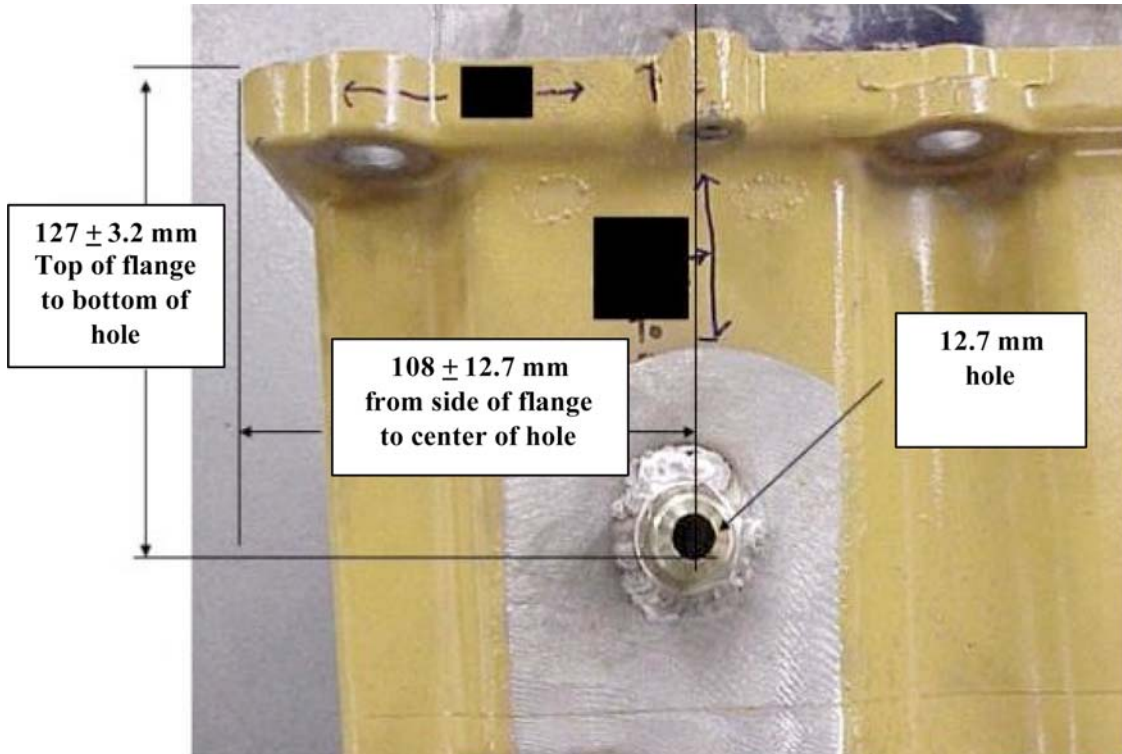
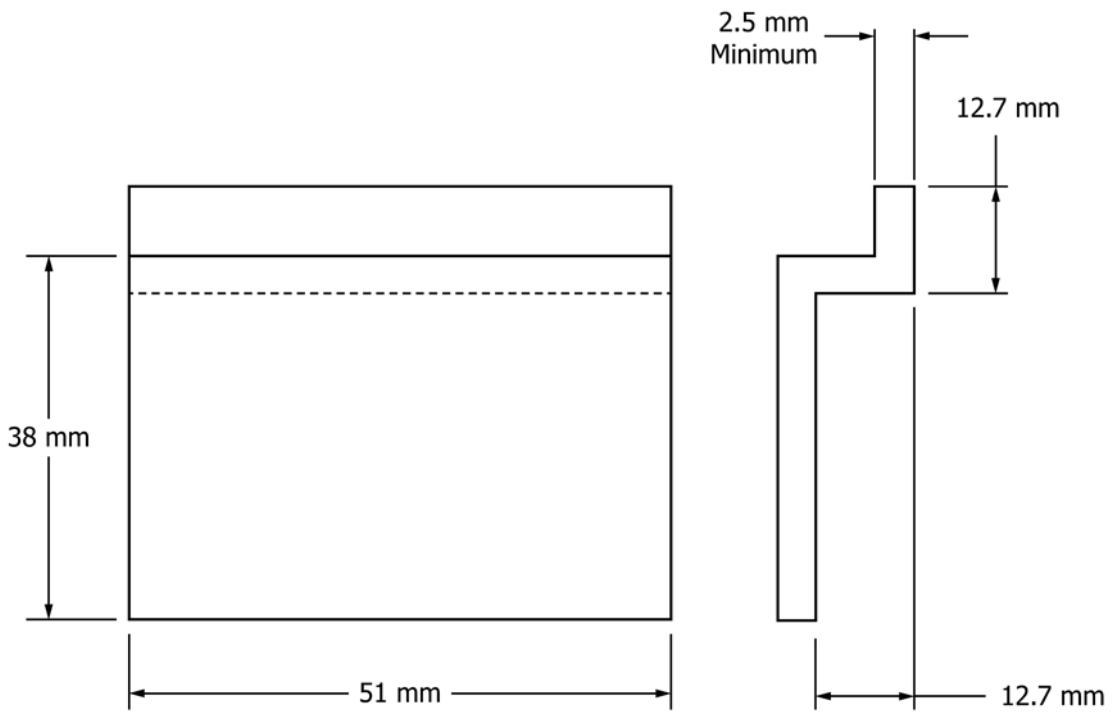

FIG. A4.1 Oil Pan Modifications for External Oil System—Auxiliary Oil System Suction Port Location



NOTE 1—Bend radii to be compatible with material thickness.

FIG. A4.2 Oil Pan Modifications for External Oil System—Suction Port Baffle Design

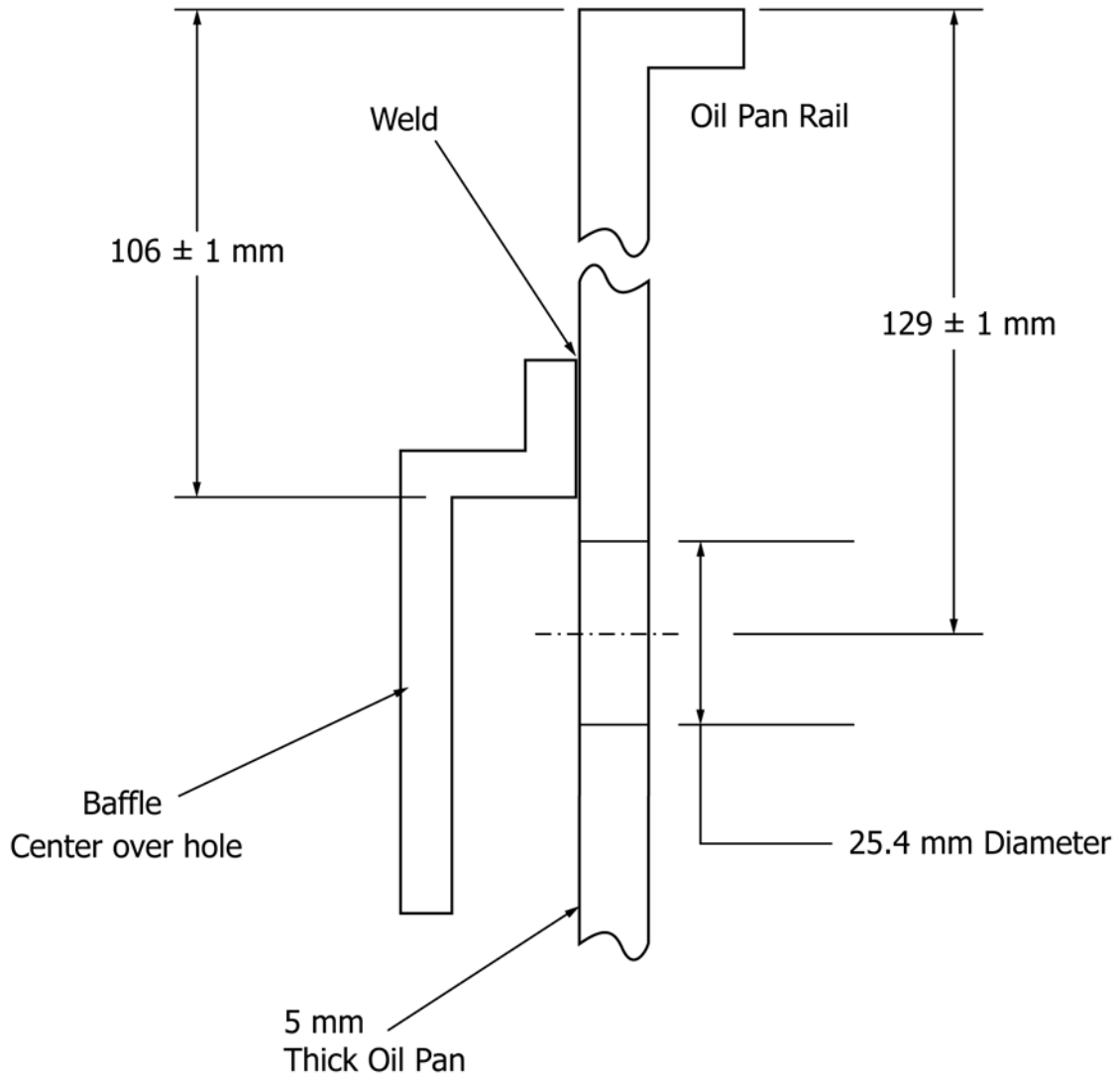

FIG. A4.3 Oil Pan Modifications for External Oil System—Baffle Placement on Oil Pan

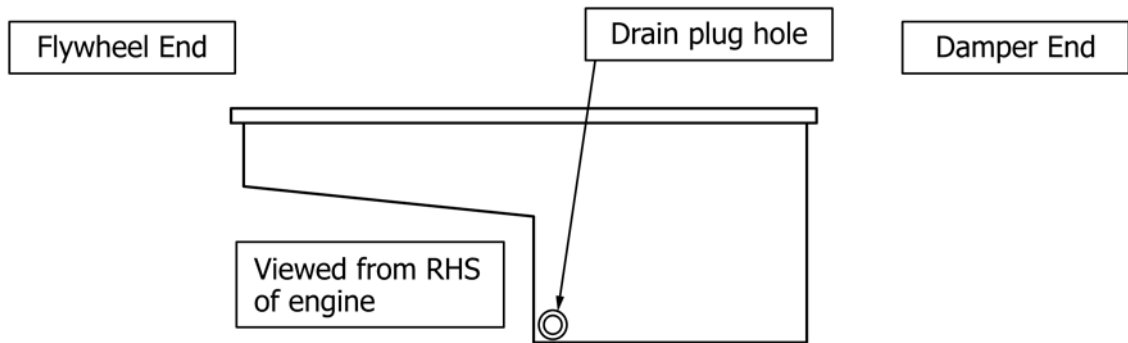

FIG. A4.4 Oil Pan Modifications for External Oil System—Auxiliary Oil System Return Port Location

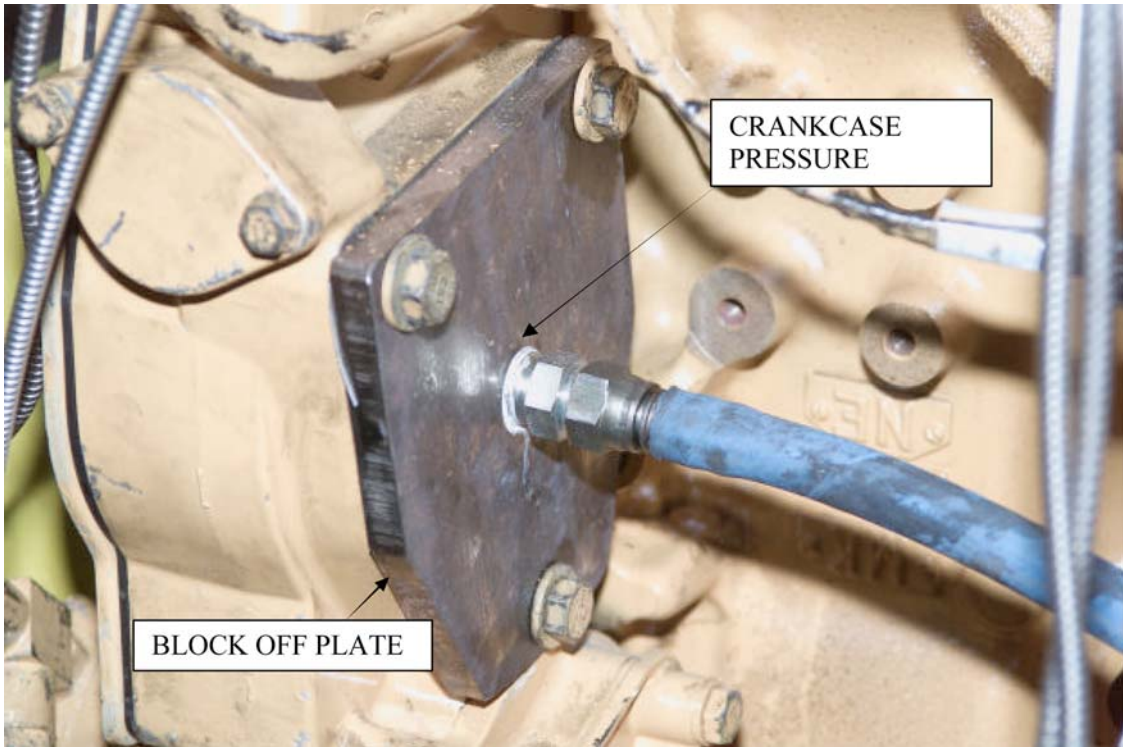

FIG. A4.5 Compressor Block off Plate and Crankcase Pressure Balance Connection

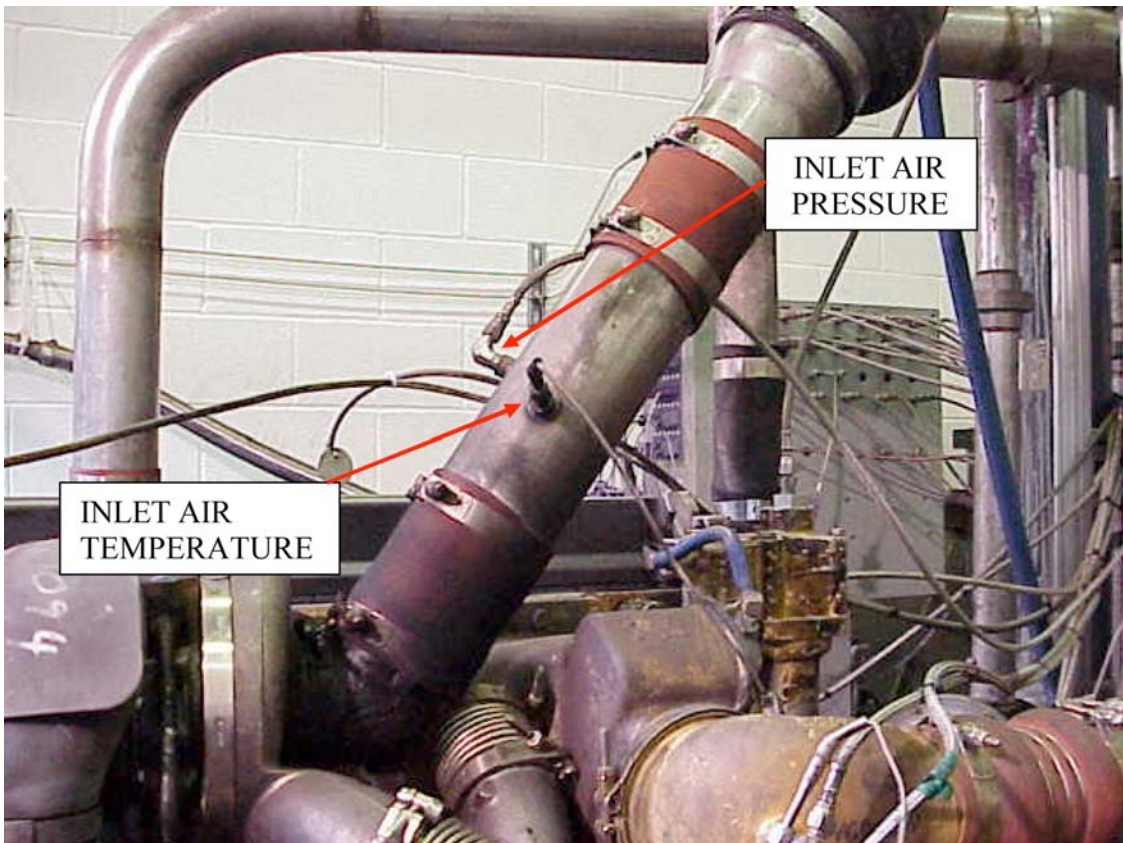

FIG. A4.6 Inlet Tube

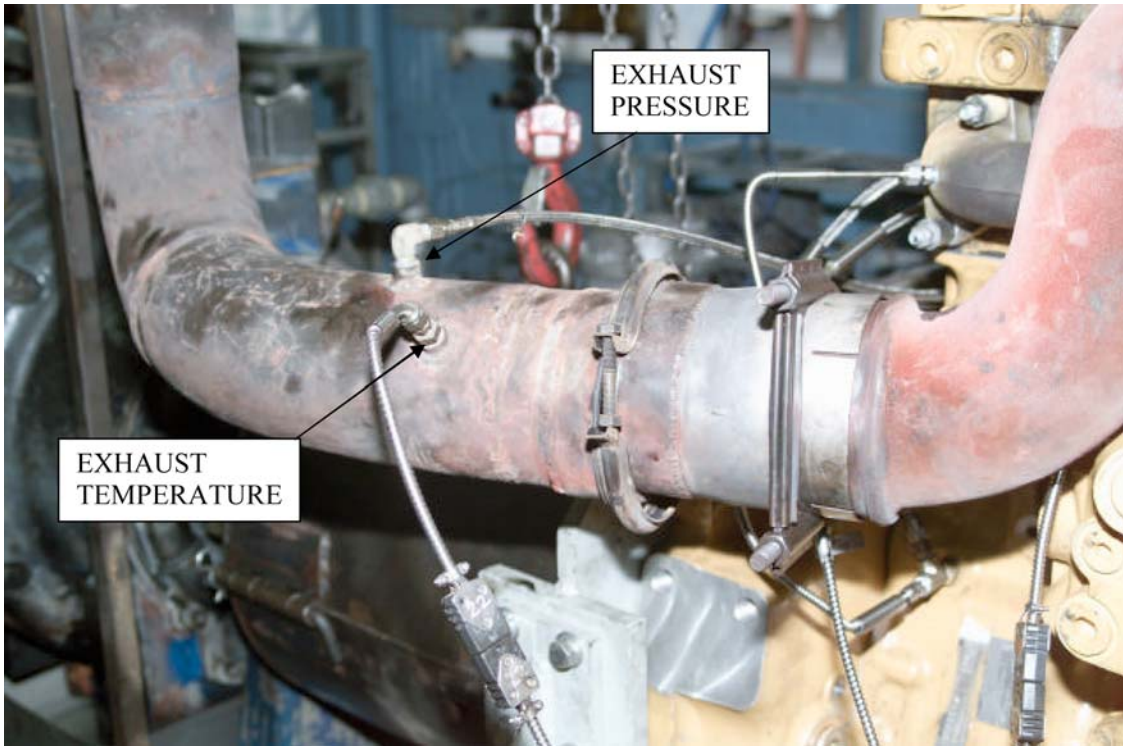

FIG. A4.7 Exhaust Tube



FIG. A4.8 Oil Filter Inlet Pressure Port



FIG. A4.9 Oil Weight Cart

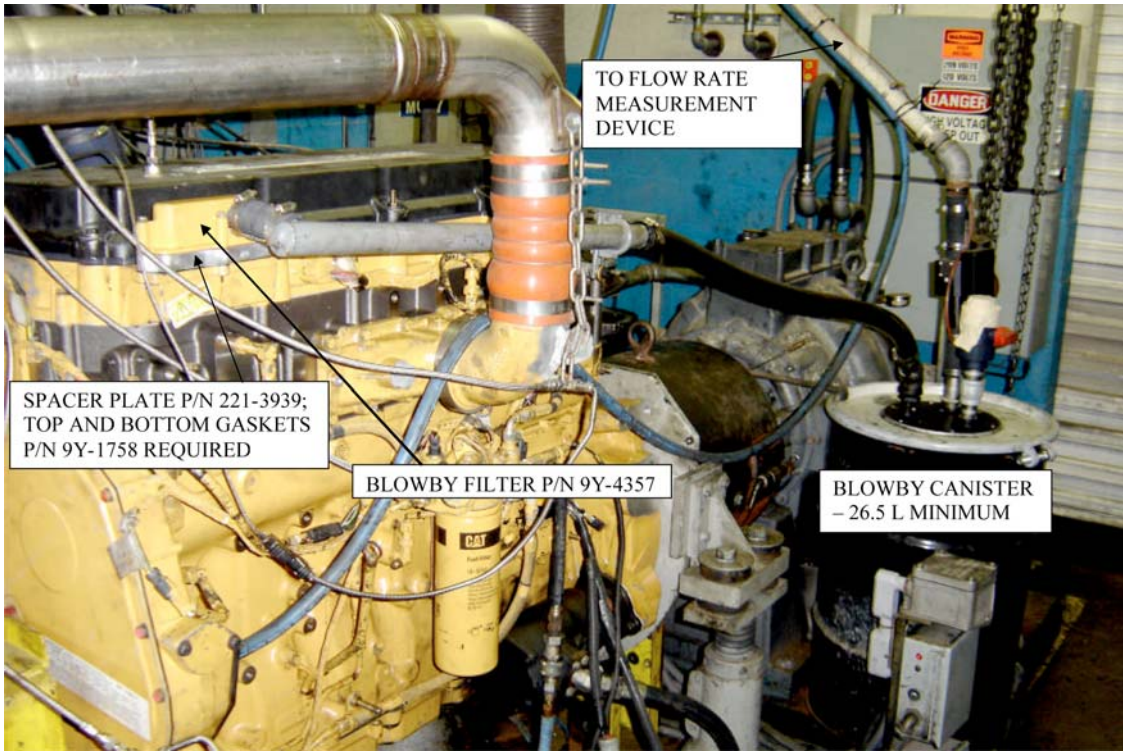

FIG. A4.10 Crankcase Aspiration System

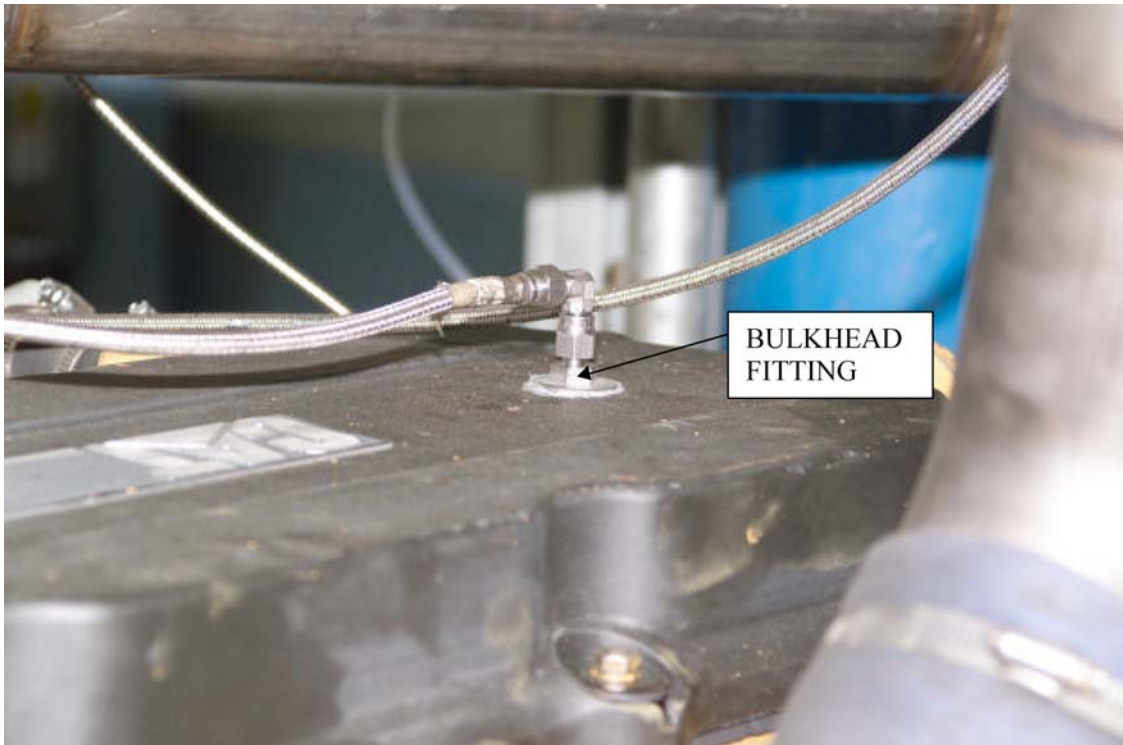

FIG. A4.11 Crankcase Pressure Connection

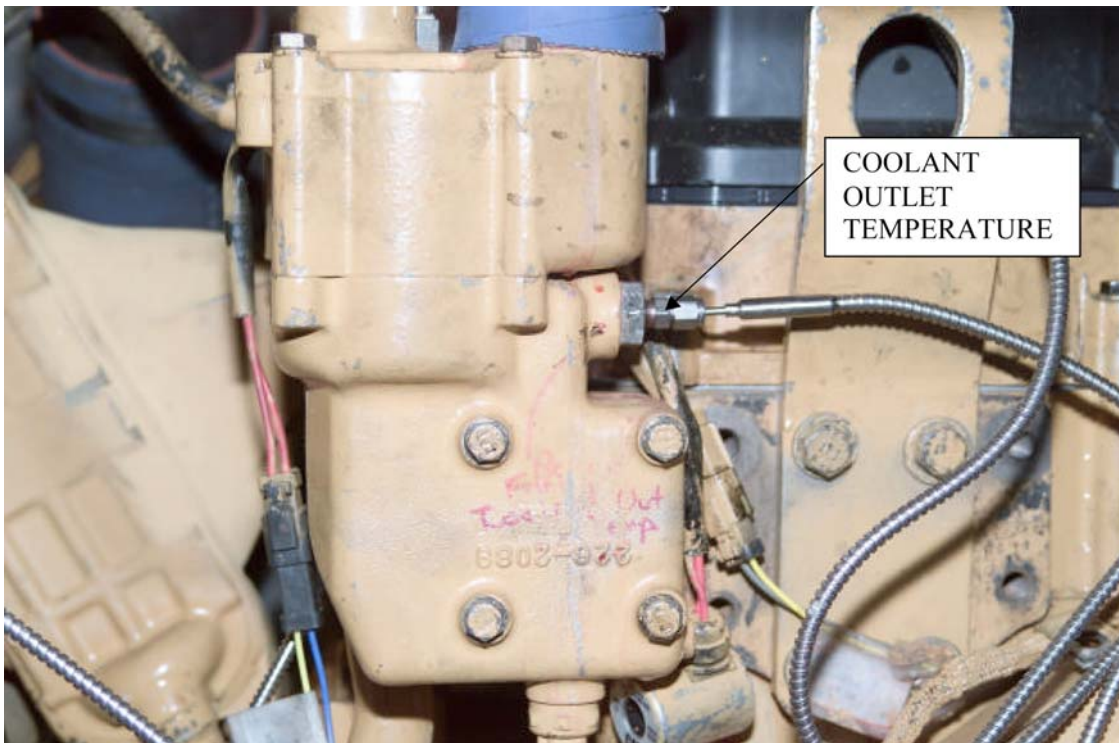

FIG. A4.12 Coolant Outlet Temperature

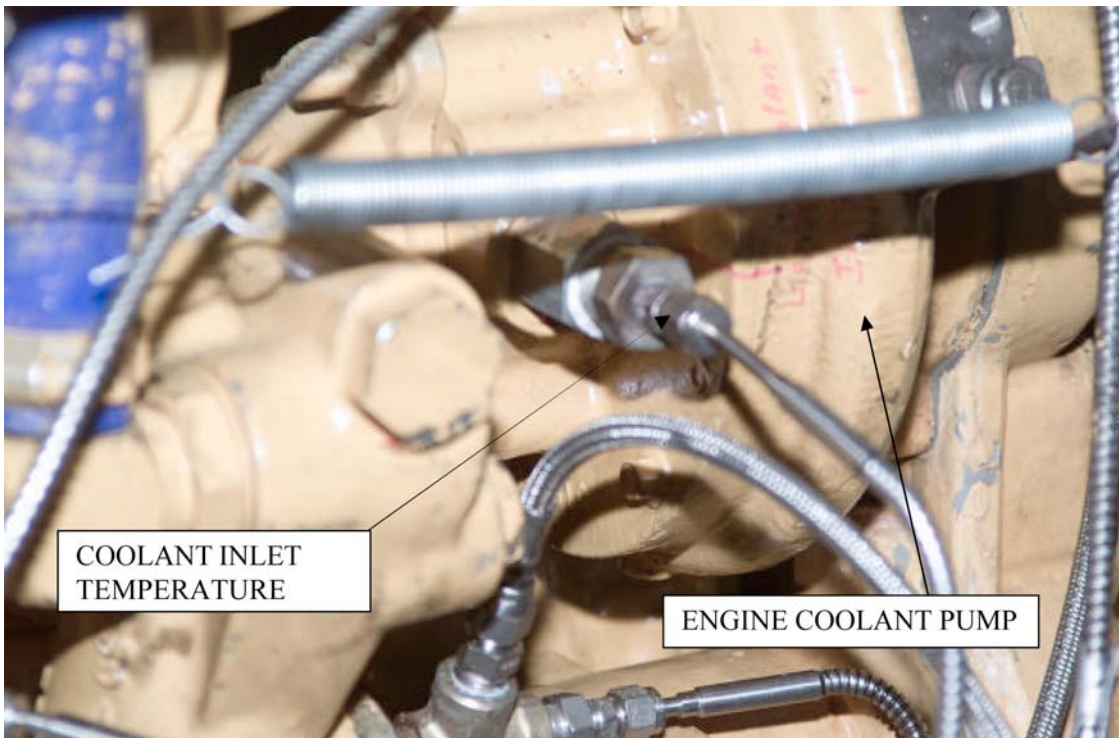

FIG. A4.13 Coolant to Engine

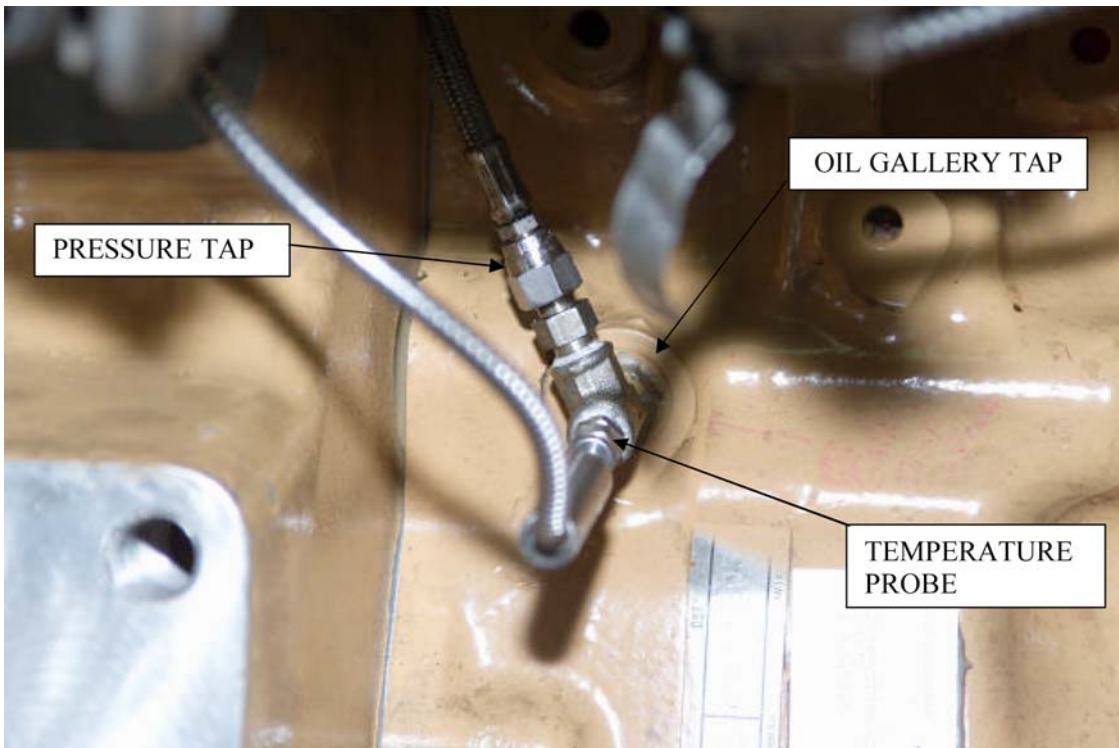

FIG. A4.14 Oil Gallery Pressure and Temperature

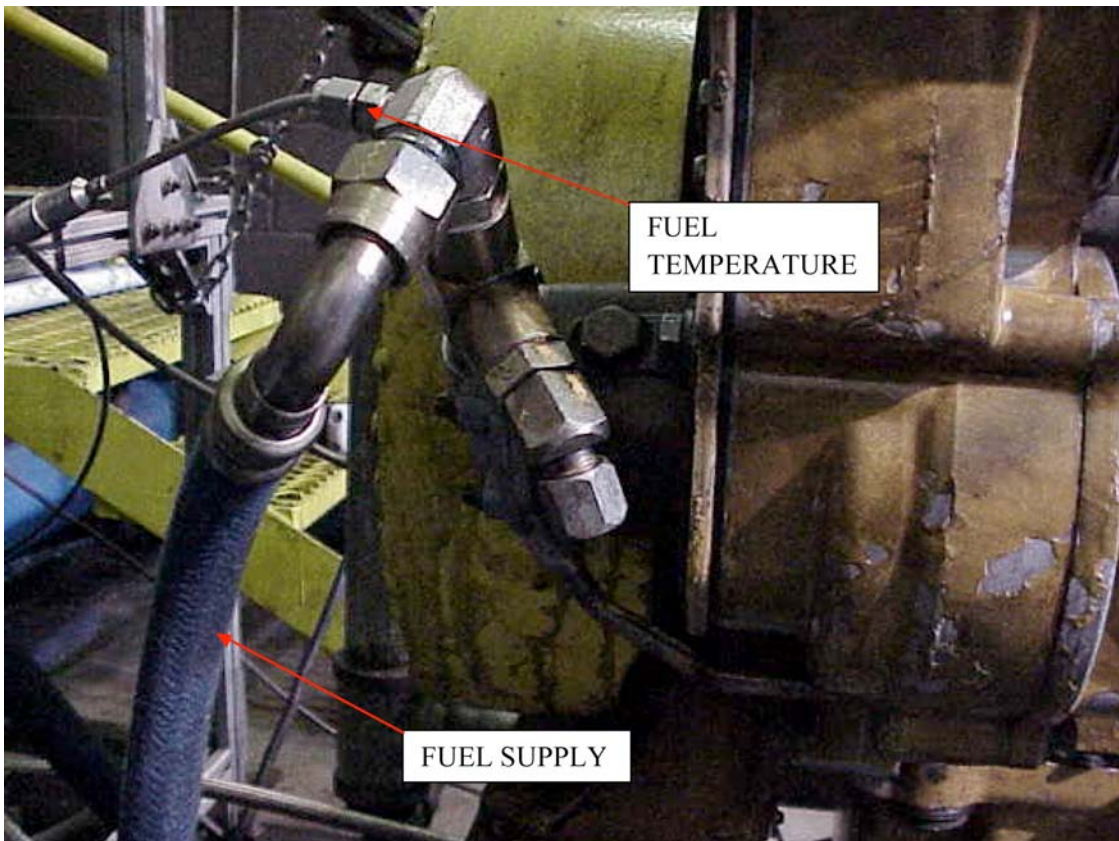

FIG. A4.15 Fuel to Engine Temperature

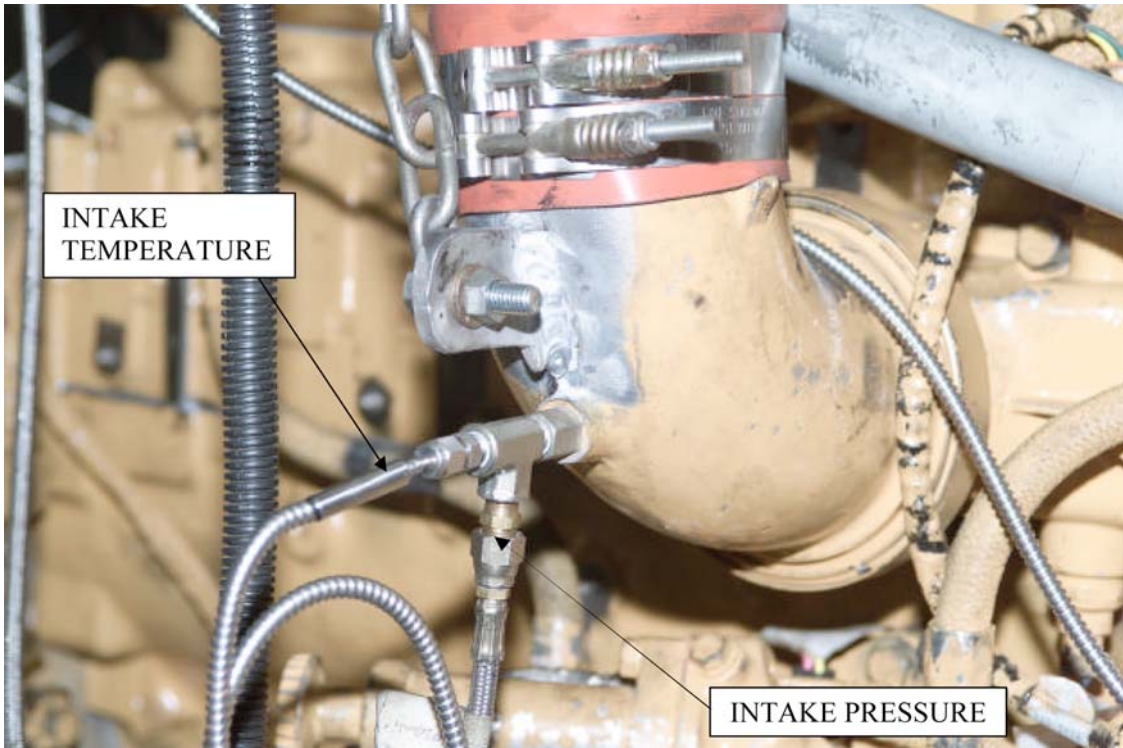

FIG. A4.16 Intake Manifold Pressure and Temperature

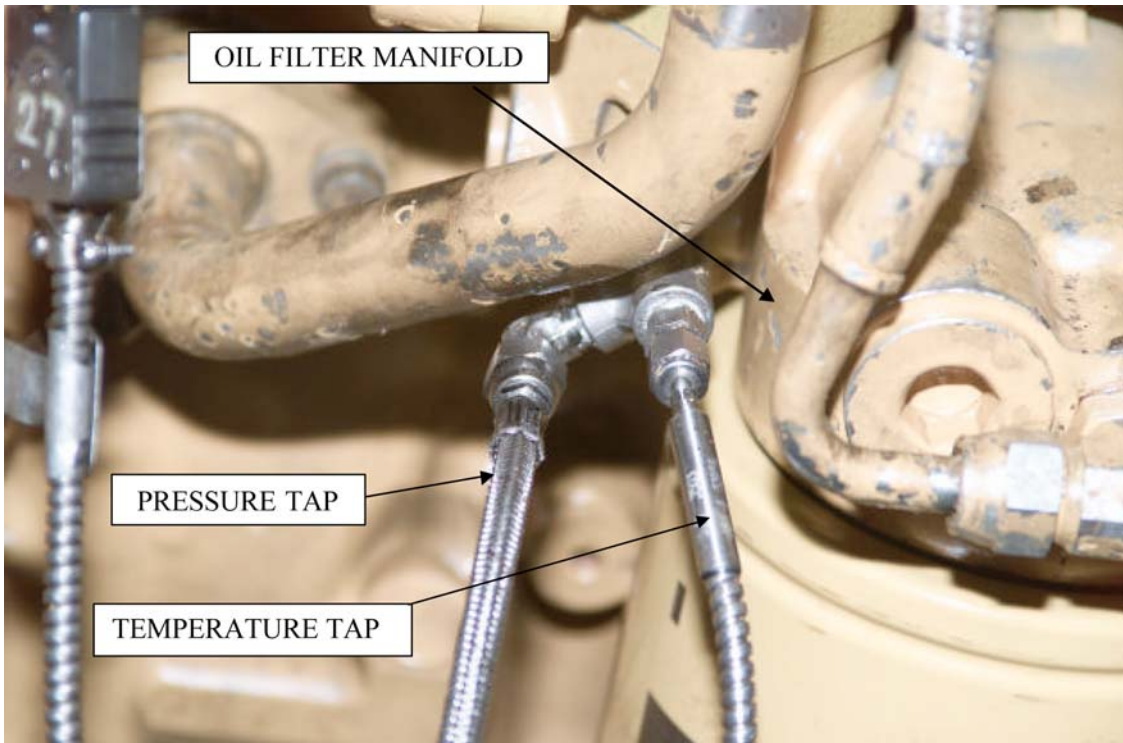

FIG. A4.17 Oil Filter Out Pressure and Temperature

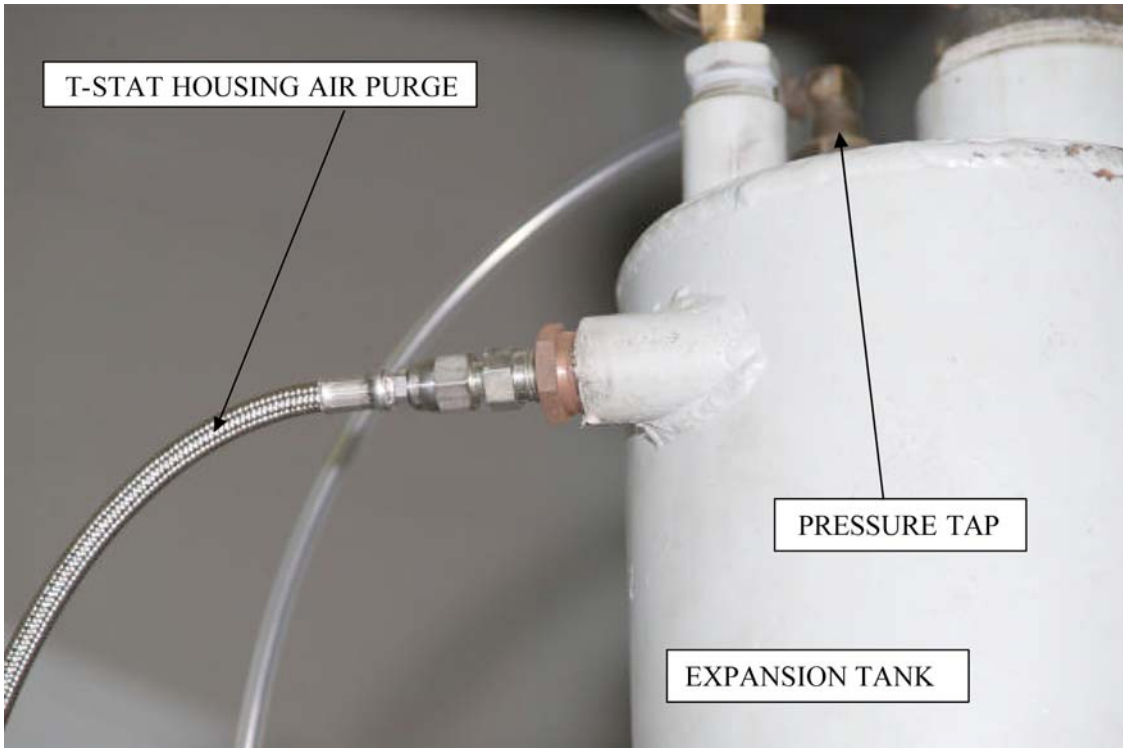

FIG. A4.18 Cooling System Pressure

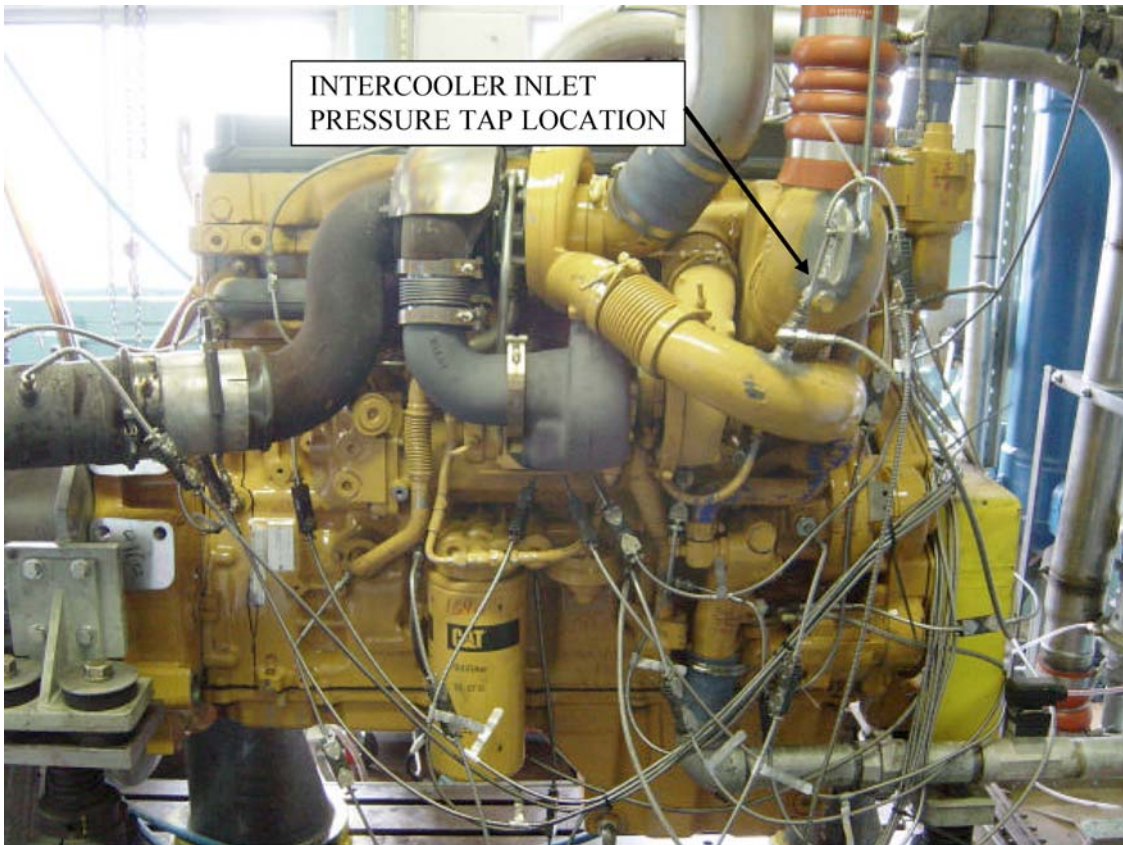

FIG. A4.19 Right Side of Installed Engine

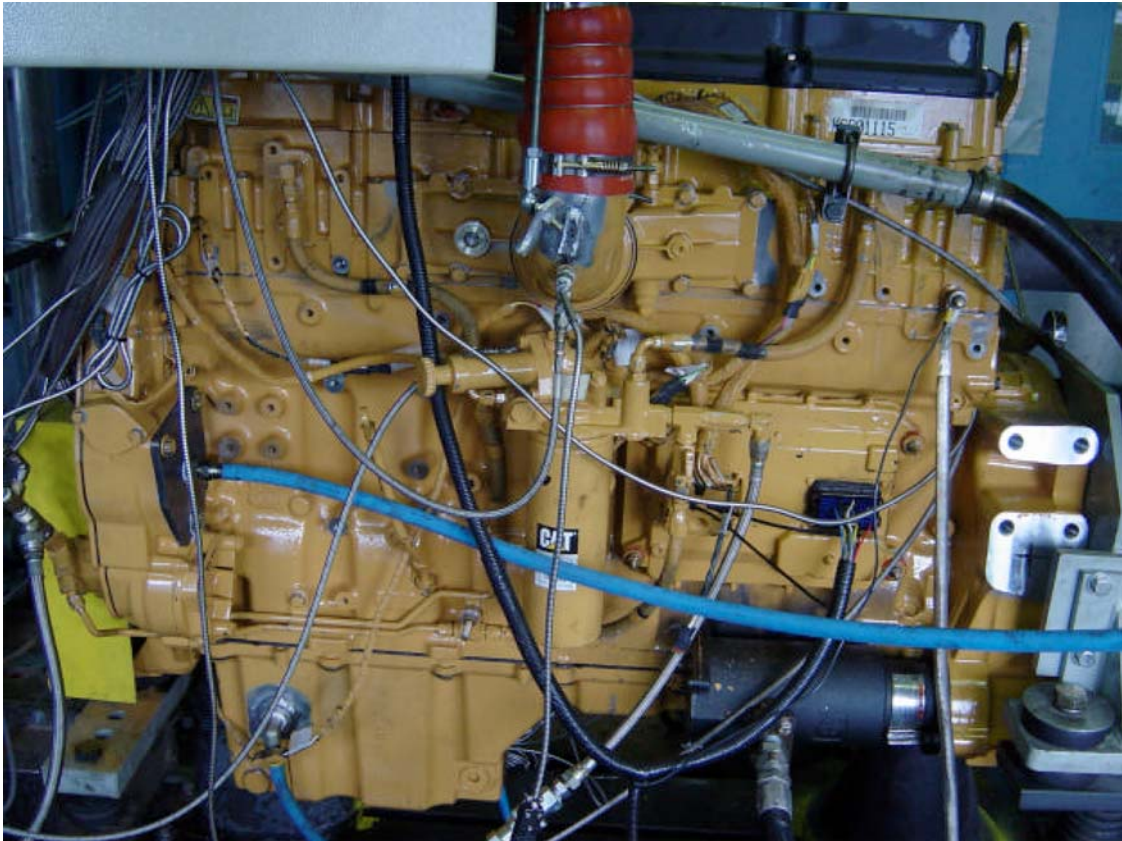

FIG. A4.20 Left Side of Installed Engine

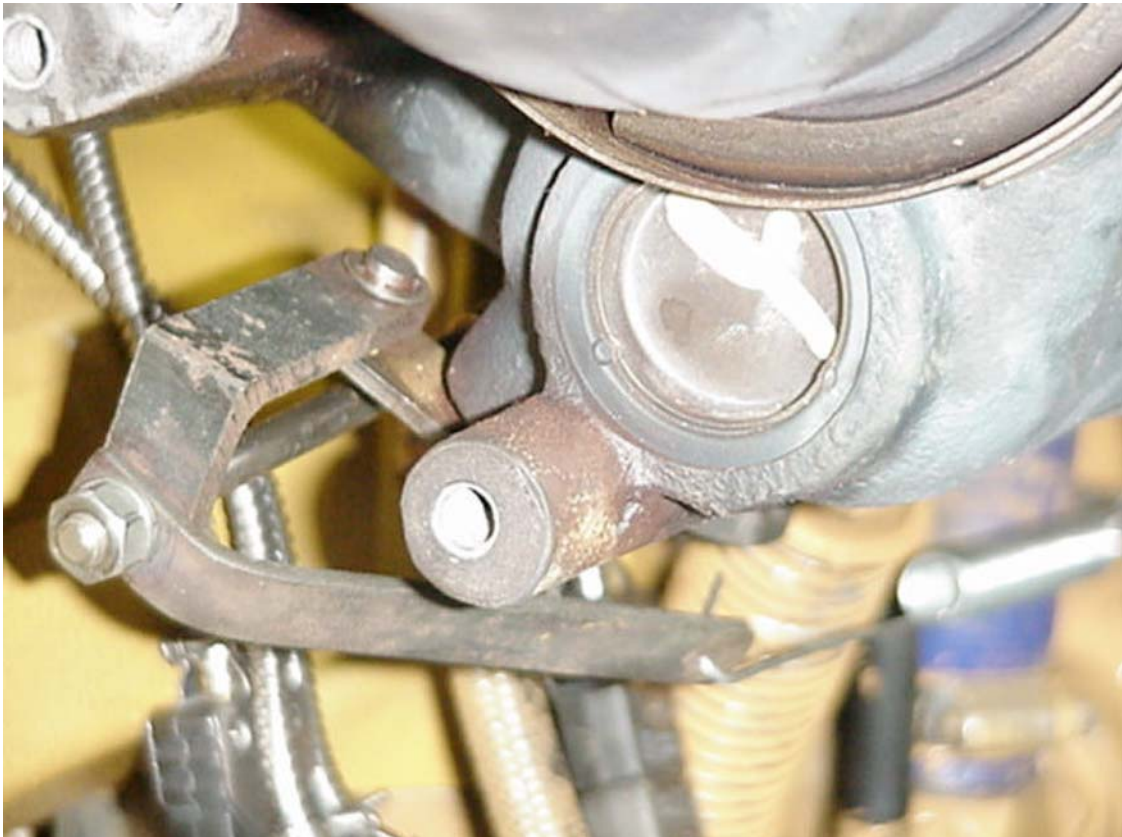

FIG. A4.21 Turbo Waste-gate Control



FIG. A4.22 Turbo Waste-gate Control Cable

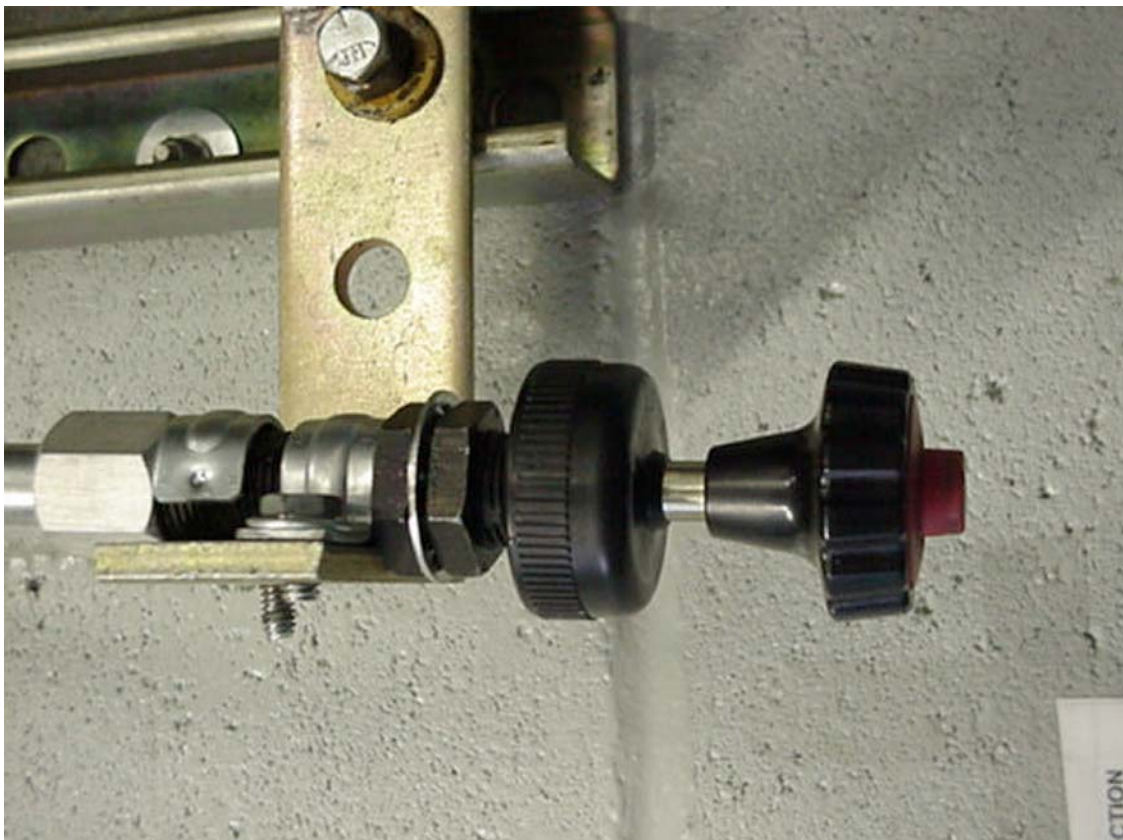

FIG. A4.23 Turbo Waste-gate Control Manual Adjuster

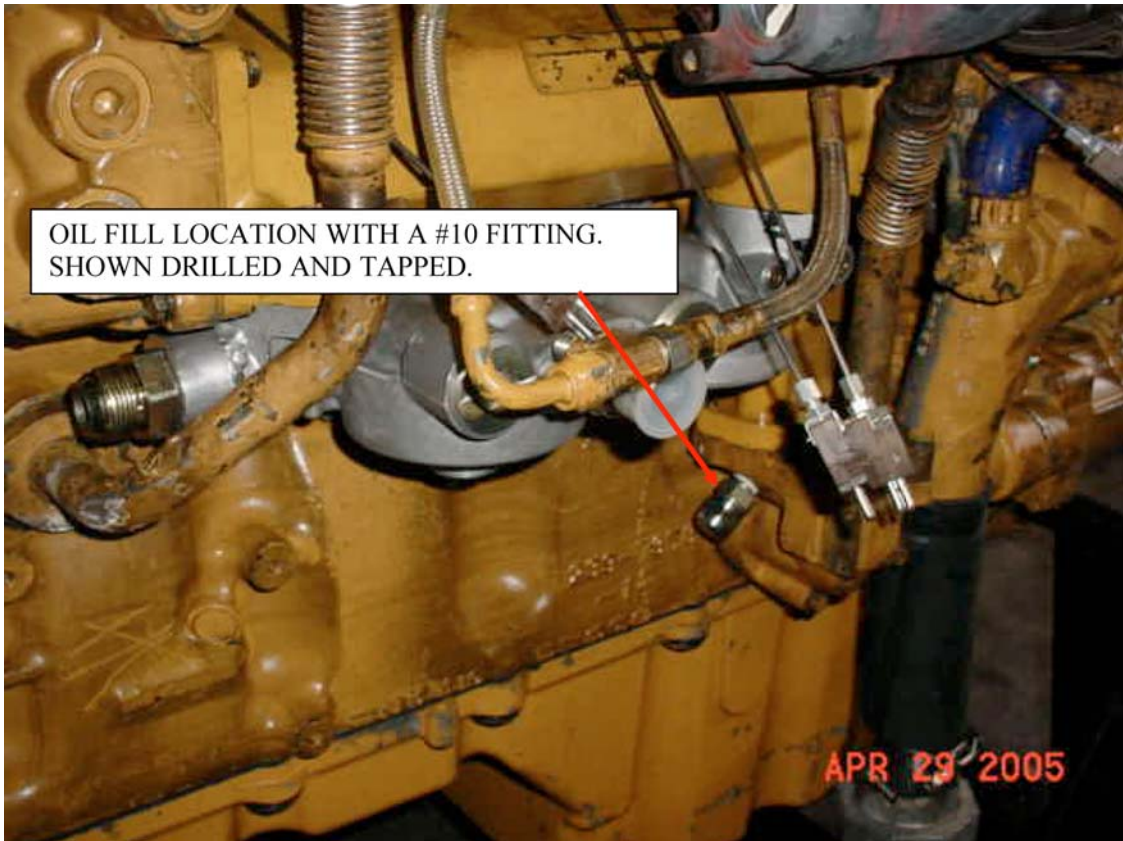

FIG. A4.24 Pressurized Oil Fill Location



FIG. A4.25 Fuel Pressure Measurement Location

A5. EXTERNAL OIL SYSTEM

A5.1 See Fig. A5.1.

Hoses:

Supply - Nominal 12 mm; max length 2.7 m

Return - Nominal 10 mm; max length 2.7 m

Vent – 12 mm minimum

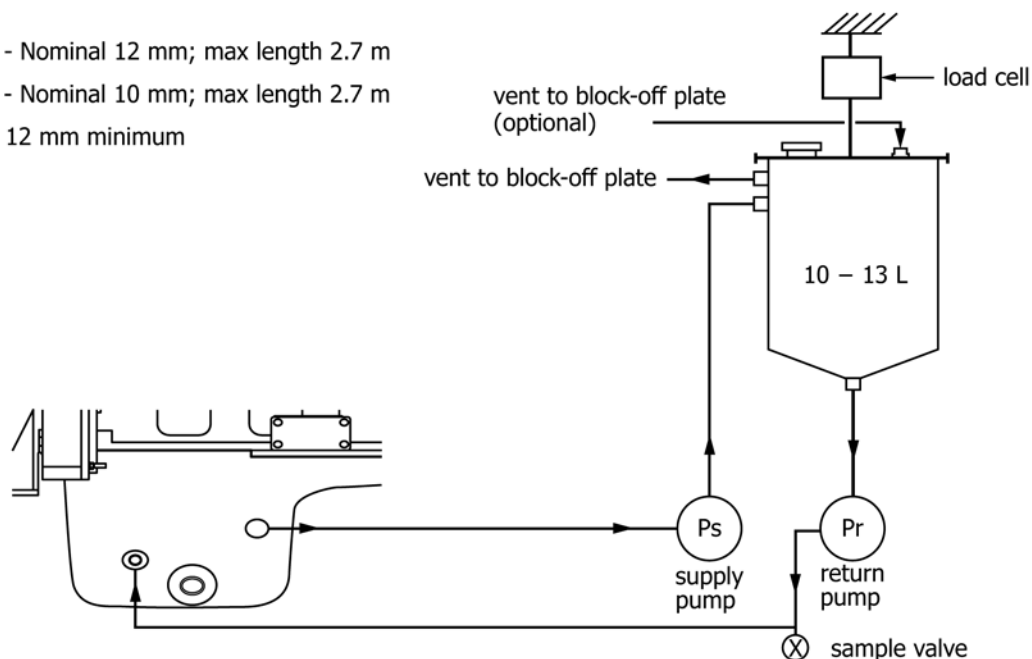

FIG. A5.1 External Oil System

A6. FUEL SPECIFICATION

A6.1 See Table A6.1.

TABLE A6.1 PC-10 ULSD Fuel Specification

Property	Limits	Test Method
Total sulfur, mg/kg	7-15	D5453
Gravity, °API	34-37	D4052
Hydrocarbon Types, Aromatics, % mass	26-31.5	D5186
Hydrocarbon Types, Olefins, % vol.	Report	D1319
Cetane Index	Report	D976
Cetane No.	43-47	D613
Copper Strip Corrosion	1 max	D130
Flash Point, °C	54 min	D93
Pour Point, °C	-18 max	D97
Carbon Residue on 10% Distillation Residue, %	0.35 max	D524
Water & Sediment, % vol.	0.05 max	D2709
Viscosity, cSt @ 40 °C	2.0-2.6	D445
Acid Number	0.05 max	D664
Strong Acid Number	0.00 max	D664
Accelerated Stability, Total Insolubles, mg/100 mL	1.5 max	D2274
Ash, % mass	0.005 max	D482
SLBOCLE, g	3100 min ^A	D6078 ^A
Distillation, 90% Distilled, °C	293-332	D86

^A May be altered to be consistent with CARB or Specification D975 for diesel fuel.

A7. CATERPILLAR SERVICE PUBLICATIONS

A7.1 Caterpillar Service Manual, Media number SENR9700.

NOTE A7.1—Contact a Caterpillar Dealer to purchase service literature.

A7.2 Caterpillar Parts Manual C-13 On-Highway Engine, Media number SEBP3735.

A8. SPECIFIED UNITS AND FORMATS

A8.1 Specified Units:

A8.1.1 *Test Report*—Record operational parameters according to **Table A8.1**. Report test results in the units and with the significant digits shown in **Table A8.2**. Round test results in compliance with Practice **E29**.

A8.1.2 *Measurements and Conversions*—Except for the exceptions noted in **1.2.1**, all parameters have been specified in SI units. The intent of this test method is to measure all parameters directly in SI units. If parameters are measured in inch-pound units, then the laboratory shall show to the TMC that the measurements are within the tolerances after conversion to SI units.

A8.1.2.1 Significant error may occur due to rounding or tolerance stacking, or both, when converting from inch-pound units to SI units.

A8.2 *Specification Format*—Specifications are listed in three formats: (1) target, (2) target and range, and (3) range with no target.

A8.2.1 *Target*—A target specification has no tolerance. Therefore, the only acceptable value is the target. A representative specification format is xx.xx (target). For example, the oil pan charge is listed as 30.8 kg.

A8.2.1.1 Do not intentionally calibrate or control a parameter with a target at a level other than the target.

A8.2.2 *Target and Range*—A target and a range specification implies that the correct value is the target and the range is intended as a guide for maximum acceptable variation about

the mean. A representative specification format is xx.xx ± x.xx (target ± range). For example, the engine speed is (1800 ± 5) r/min.

NOTE A8.1—The mean of a random sample should be equivalent to the target. Operation within the range does not imply that the parameter will not bias the final test results.

A8.2.3 *Range with No Target*—A range with no target specification is used when (1) the parameter is not critical and control within the range is sufficient or (2) the measurement technique is not precise, or both. A representative format is xx.xx – xx.xx (range_{low} – range_{high}). For example, the system coolant pressure is (99 to 107) kPa.

TABLE A8.1 Piston Rating Locations

Parameter	Record Data to Nearest
Speed	1 rpm
Power	1 kW
Torque	1 N.m
Fuel Flow	1 g/min
Coolant In Temperature	0.1 °C
Coolant Out Temperature	0.1 °C
Fuel In Temperature	0.1 °C
Oil Gallery Temperature	0.1 °C
Intake Air Temperature	0.1 °C
Exhaust (Tailpipe) Temperature	1 °C
Intake Manifold Pressure	0.1 kPa
Crankcase Pressure	0.01 kPa
Exhaust Pressure	0.1 kPa
Carbon Dioxide	0.01 %

TABLE A8.2 Significant Digits for Test Results

Parameter	Round Off to Nearest
Mass Loss	0.1 mg
Oil Consumption	0.1 g
Piston Ratings	0.1 rating unit

A9. PISTON RING LOCATIONS

A9.1 Rate each piston/ring combination for ring sticking and for sluggish rings as removed from the engine, and then again after a solvent rinse. After the rinse, measure each piston/ring combination for loss of side clearance. Finally remove the rings from the pistons and rate the pistons. See [Table A9.1](#).

TABLE A9.1 Piston Rating Locations

Location/Deposit	Special Instructions
Grooves	
Top Groove Fill	
Intermediate Groove Fill	
"C" Groove Fill	
Groove No. 1	Rate HC, MC, LC and Lacquer
Groove No. 2	Rate HC, LC
Groove No. 3	Rate HC, MC, LC
Lands	
Top Land Heavy Carbon	
Top Land % Flaked Carbon	
Lands No. 1 – No. 4	Rate HC, LC
Lands No. 1, No. 2	Lacquer
Other	
Undercrown	Rate separately from grooves and lands

A10. OIL ANALYSES

A10.1 Perform at test hours 0, 4, 50, 100, 150, 200, 250, 300, 350, 400, 450, 500 the following tests on the engine oil: (1) Viscosity @ 100 °C by Test Method [D445](#), (2) Base No. by Test Method [D4739](#), (3) Acid No. by Test Method [D664](#), (4) Oxidation by Test Method [D6987/D6987M](#) (T-10) Integrated IR, (5) Wear Metals, Al, Cr, Cu, Fe, Pb, Si by Test Method [D5185](#).

A10.2 Perform at test hours 50, 250, 500 the following tests on the engine oil: (1) Fuel Dilution by Test Method [D3524](#), (2) TGA Soot by Annex A4 of Test Method [D5967](#).

A11. DETERMINATION OF OPERATIONAL VALIDITY

A11.1 Calculation and Reporting of Quality Index (QI):

A11.1.1 Calculate the QI for all control parameters according to the DACA II Report. Account for missing or bad quality data according to the DACA II Report.

A11.1.2 Use the U, L, Over Range and Under Range values shown in [Table A11.1](#) for the Q I calculations.

A11.1.3 Round off the calculated QI values to the nearest 0.001 and report them.

A11.2 Calculation and Reporting of Averages:

A11.2.1 Calculate the averages for control and non-control parameters, and report the values. With the exception of non-QI and ranged parameters, the averages are not directly

used to determine operational validity, but may be helpful when an engineering review is required (A11.4).

A11.3 Determination of Operational Validity:

A11.3.1 Both (1) QI threshold values for operational validity and (2) specifications for non-QI control parameters and ranged parameters are shown in Table A11.1.

A11.3.1.1 A test with all control parameter QI values greater than or equal to the threshold value and with averages for all non-QI control parameters and all ranged parameters within specifications is operationally valid provided that no other operational deviations exist that may cause the test to be declared invalid.

A11.3.1.2 Perform an engineering review to determine operational validity for a test with any control parameter QI value less than the threshold value shown in Table A11.1.

A11.4 Performing an Engineering Review:

A11.4.1 Perform an engineering review when a control parameter QI value is below the threshold value. An engineer-

ing review is the examination of test data to determine the cause of a QI value's being below threshold. Its aim is to determine whether there was a real control problem and the possible impact on the test. For example, a test shows a low QI value for fuel flow. An examination of the fuel flow data may show that the data contains several over range values. An examination of the exhaust temperatures may help to determine whether the instrumentation problem affected real fuel flow or only affected the data acquisition.

A11.4.2 Conduct engineering reviews for reference tests jointly with the TMC. Obtain optional input from the TMC for engineering reviews of non-reference tests.

A11.4.3 Determine operational validity based upon the engineering review and summarize the decision in the comment section of the test report. Supporting documentation may be included at the end of the report. The laboratory makes the final decision regarding operational validity.

TABLE A11.1 Quality Index (QI) Calculation Values

Control Parameter	Unit	Quality Index Threshold	Quality Index U & L Values		Over & Under Range Values	
			U	L	High	Low
Speed	rpm	0.000	1802.5	1797.5	1937	1663
Fuel Flow	kg/h	0.000	1203	1197	1364	1036
Intake Air Temperature	°C	0.000	26	24	79.8	-29.8
Intake Manifold Temperature	°C	0.000	40.5	39.5	67.4	12.6
Fuel In Temperature	°C	0.000	40.4	39.6	61.9	18.1
Coolant Out Temperature	°C	0.000	88.4	87.6	109.9	66.1
Oil Gallery Temperature	°C	0.000	98.3	97.7	114.4	81.6
Exhaust Back Pressure	kPa	0.000	6.3	5.7	22.4	-10.4
Non-QI Control Parameter	Unit		Specification		Over & Under Range Values	
					High	Low
Inlet Air Pressure	kPa		93 ± 1.5		175	11
Ranged Parameter	Unit		Range		High	Low
Intake Manifold Pressure	kPa		275-285		554	6

A12. OIL TEMPERATURE CONTROL SYSTEM

A12.1 *System Details*—See Figs. A12.1-A12.4 for details of the auxiliary oil heat exchanger setup.

A12.2 *Heat Exchanger*—Use an ITT Standard SSCF heat exchanger, P/N SN5160030014004.

A12.3 *Oil Lines and Fittings*—Use two size No.16 oil lines with a maximum length of 914 mm (Total of both lines), preferably made from stainless steel braided hose . Use size No.16 NPT threaded fittings for the line connections.

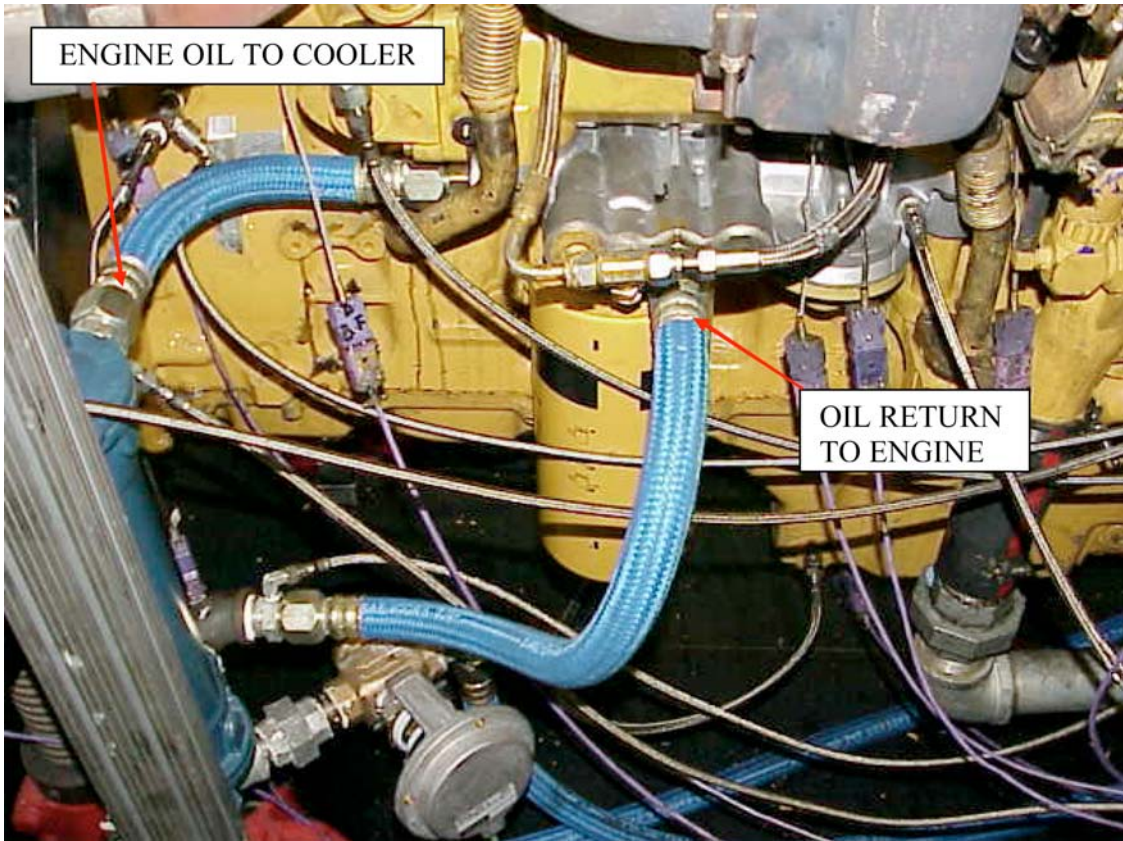

FIG. A12.1 Remote Oil Heat Exchanger

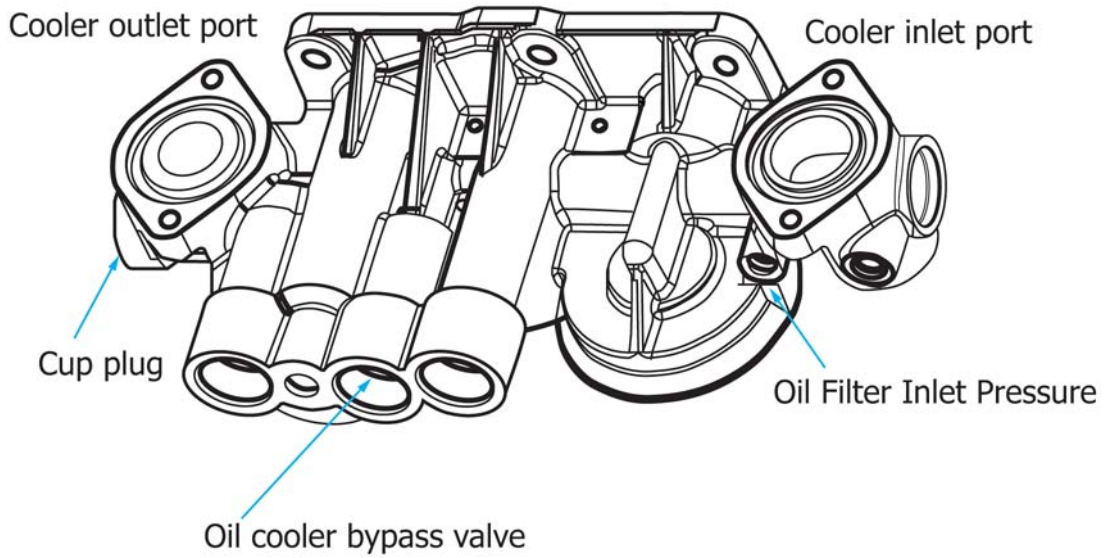

FIG. A12.2 Filter Base (P/N 251-6668) View

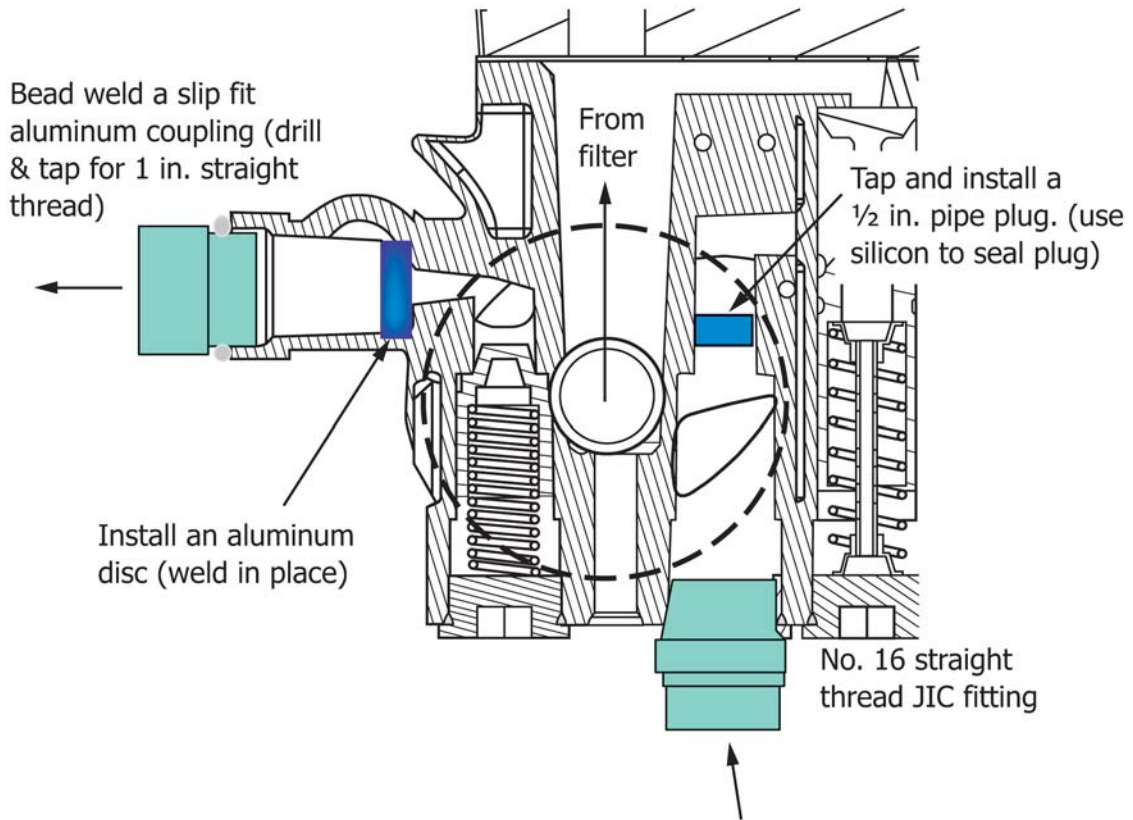
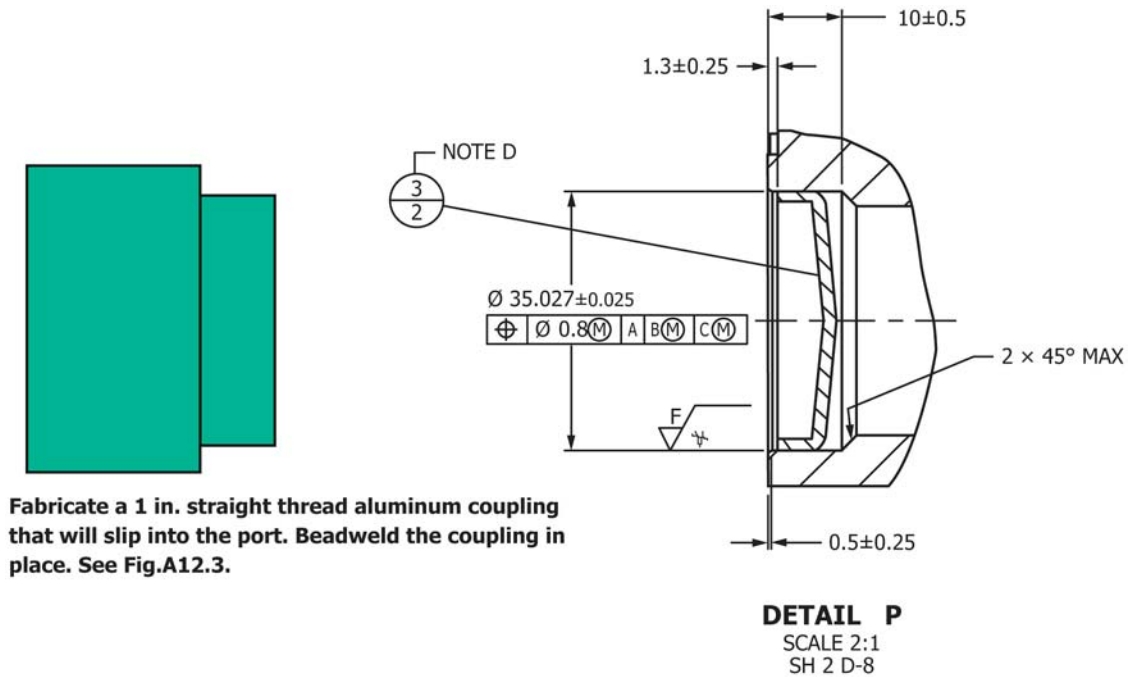

FIG. A12.3 Filter Base Modifications



NOTE 1—Units in millimetres.

FIG. A12.4 Details of Cup Plug Feature at Back End of Filter Base

A13. C13 OUTLIER SCREENING METHODS

A13.1 Average Top Groove Carbon:

A13.1.1 Calculate the average top groove carbon using all rings and report the data on the appropriate forms.

A13.1.2 For each piston, calculate the top groove carbon relative offset as:

$$TGCOffset_{piston} = TGC_{piston} - ATGC - RPTGC_{piston} \quad (A13.1)$$

where:

- TGC_{piston} = top groove carbon for the piston, dem.,
- ATGC = average top groove carbon from A13.1.1, dem.,
- RPTGC_{piston} = reference relative top groove carbon profile from Table A13.1,
- ATGCO = average of the six TGCOffset_{pistons}, and
- Piston = 1,2,3,4,5,6.

A13.1.3 If $\max |TGCOffset_{piston}| / SDTGCO > 1.887$, the outlier screened average top groove carbon is the average of the top groove carbons for the five pistons for which $|TGCOffset_{piston}|$ is not maximized plus $RRPTGC_{piston}/6$ for the piston where it is maximized.

$$\text{where } SDTGCO = \sqrt{\sum_{cylinder=1}^6 (TGCOffset_{cylinder} - ATGCO)^2/5} \quad (A13.2)$$

A13.1.4 If $\max |TOffset_{piston}| / SDTGCO \geq 1.887$, the outlier screened average top groove carbon is identical to the average top groove carbon from A13.1.1.

A13.2 Average Top Land Carbon:

A13.2.1 Calculate the measured average top land carbon and report the value on the appropriate form.

A13.2.2 Use Practice E178, two-sided test at 95 % significance level, to determine if any of the top land carbon levels are outliers. Report the outlier screened average top land carbon on the appropriate form. If no outliers were identified, this value will be identical to the measured value calculated in A13.2.1.

A13.3 Average Second Ring Top Carbon:

A13.3.1 Calculate the measured average second ring top carbon and report the value on the appropriate form.

A13.3.2 Use Practice E178, two-sided test at 95 % significance level, to determine if any of the second ring top carbon values are outliers. Report the outlier screened average second ring top carbon on the appropriate form. If no outliers were identified, this value will be identical to the measured value calculated in A13.3.1.

TABLE A13.1 Top Groove Carbon Relative Profiles

Piston	1	2	3	4	5	6
Relative Profile	5.38	-0.39	-0.71	-3.15	-1.43	0.30

A14. C13 MERIT RATING CALCULATION

A14.1 Merit System Components :

A14.1.1 Anchors—anchor performance level based on one test.

A14.1.2 Maxima—limit of acceptable performance.

A14.1.3 Minima—best achievable result.

A14.1.4 Weights—relative contribution to total merit.

A14.1.5 Multipliers—Using Table A14.1, determine the multiplier for each parameter as follows:

A14.1.5.1 If a result is at the anchor, the multiplier is one (for example, a top groove carbon of 46 yields a multiplier of 1).

A14.1.5.2 If a result is at or below the minimum, the multiplier is two (for example, a top groove carbon of 30 yields a multiplier of 2).

A14.1.5.3 If a result is at the maximum, the multiplier is zero (for example, a top groove carbon of 53 yields a multiplier of 0).

A14.1.5.4 If a result is between anchor and minimum, determine the multiplier by interpolating between 1 and 2 (for example, a top groove carbon of 42 yields a multiplier of 1.25).

A14.1.5.5 If a result is between maximum and anchor, determine the multiplier by interpolating between 0 and 1 (for example, a top groove carbon of 50 yields a multiplier of 0.43).

A14.1.5.6 If a result is above the maximum, linearly extrapolate the multiplier on the same line as between 1 and (for example, a top groove carbon of 57 yields a multiplier of -0.57).

A14.2 *Calculated Merit Result*—Sum the products of weight and multipliers across the four results. This is the calculated merit result. In equation form it is:

$$\text{Calculated Merit} = \sum_{i=1} \text{Weight}_i \times \quad (\text{A14.1})$$

$$\left\{ \begin{aligned} &\delta(\text{result}_i > \text{anchor}_i) \times (\text{max}_i - \text{result}_i) / (\text{max}_i - \text{anchor}_i) \\ &+ \delta(\text{min}_i < \text{result}_i \leq \text{anchor}_i) \times [1 + (\text{anchor}_i - \text{result}_i) / (\text{anchor}_i - \text{min}_i)] \\ &+ \delta(\text{result}_i \leq \text{min}_i) \times 2 \end{aligned} \right\}$$

A14.2.1 Report the results of the merit calculations on the appropriate form.

APPENDIX

TABLE A14.1 Multiplier for Each Parameter

Criterion	Top Groove Carbon	Top Land Carbon	Second Ring Carbon	Delta Oil Consumption
Weight	300	300	100	300
Maximum	53	35	33	31
Anchor	46	30	22	25
Minimum	30	15	5	10

(Nonmandatory Information)

X1. TYPICAL SYSTEM CONFIGURATIONS

X1.1 See Figs. X1.1-X1.3.

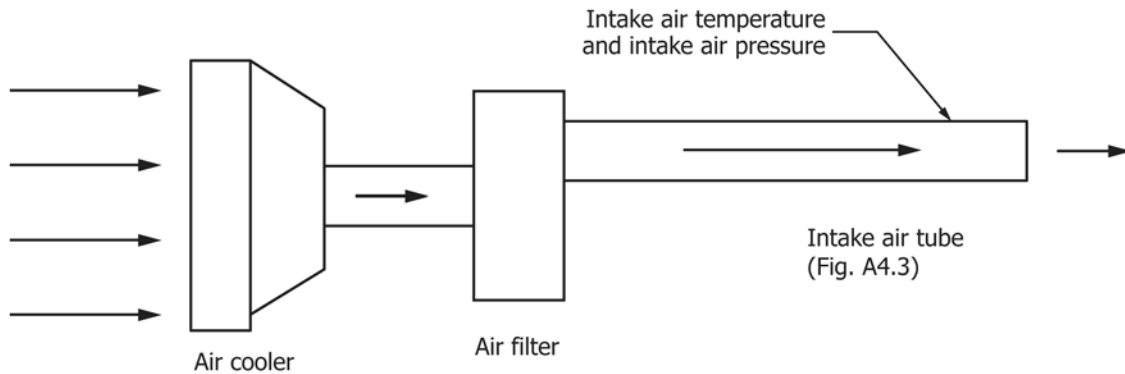

NOTE 1—See Fig. A4.6.

FIG. X1.1 Intake Air System (Typical)

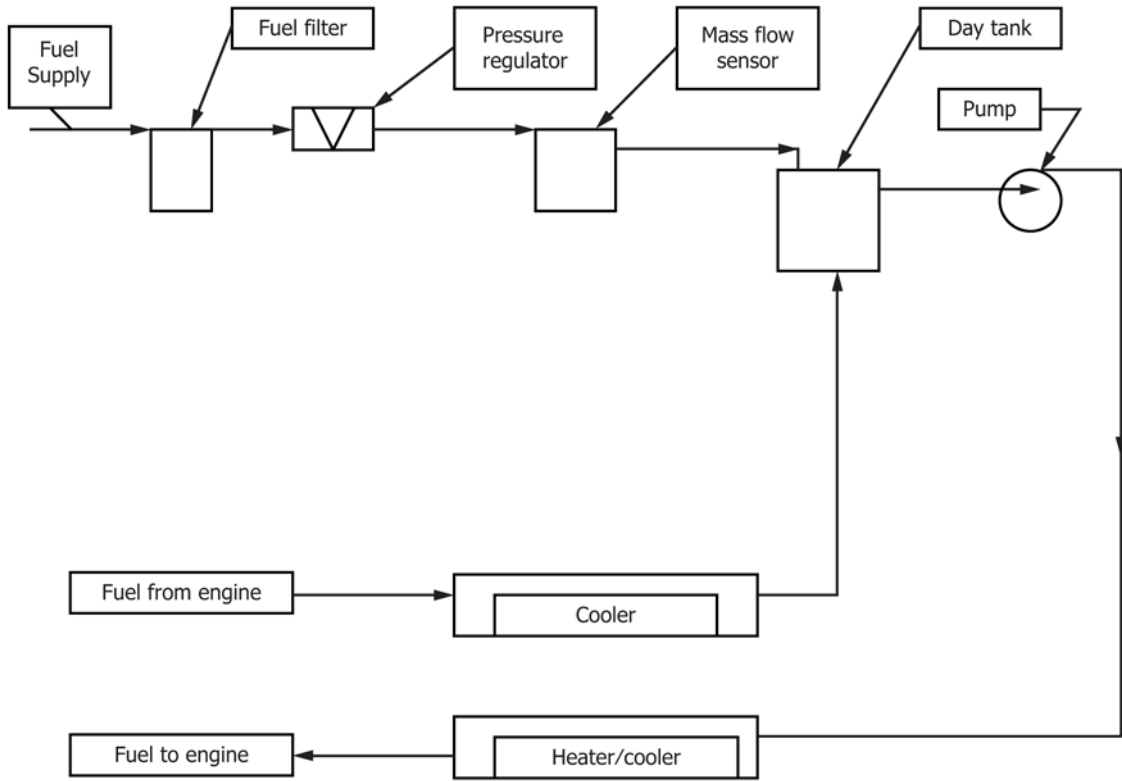

FIG. X1.2 Fuel System (Typical)

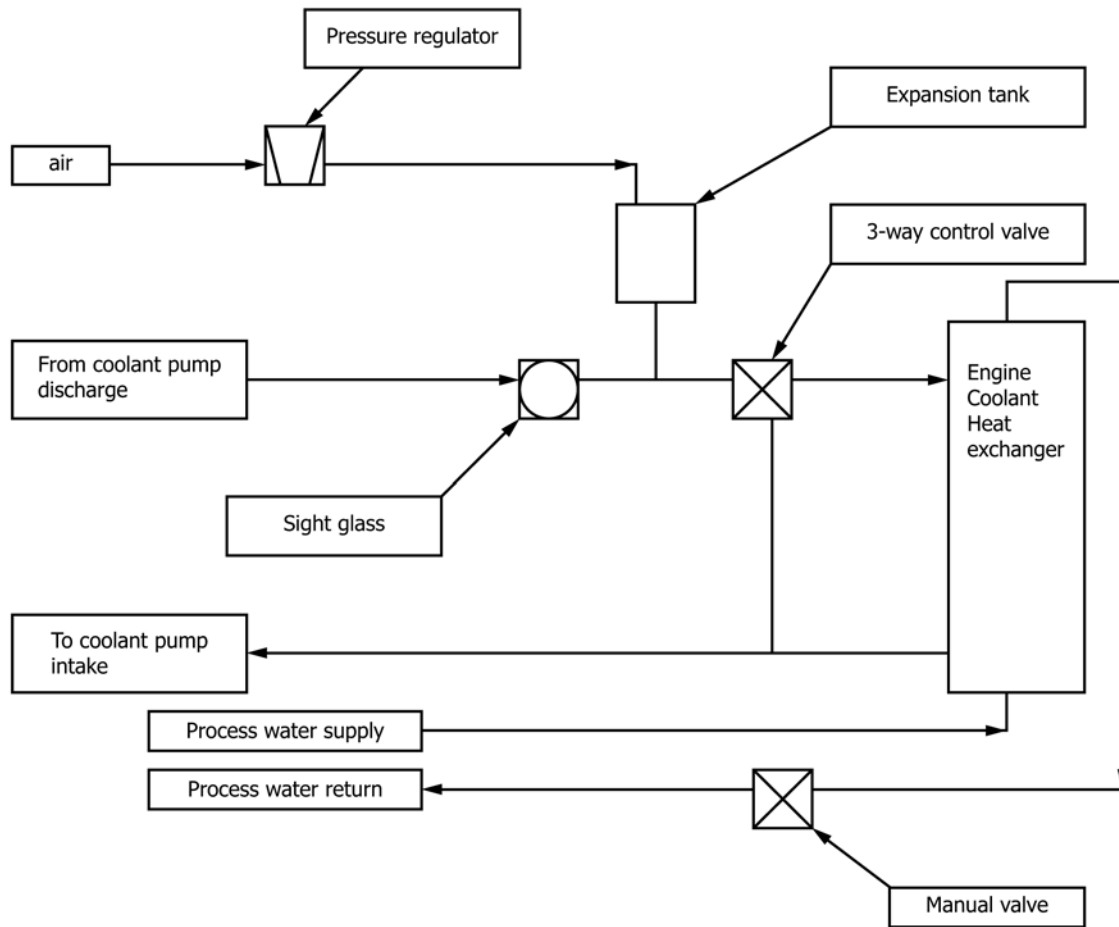

FIG. X1.3 Coolant System (Typical)

SUMMARY OF CHANGES

Subcommittee D02.B0 has identified the location of selected changes to this standard since the last issue (D7549 – 16) that may impact the use of this standard. (Approved May 1, 2017.)

(1) Subsection 11.4, revised to clarify the oil consumption calculation in case of shutdown.

Subcommittee D02.B0 has identified the location of selected changes to this standard since the last issue (D7549 – 15a) that may impact the use of this standard. (Approved April 1, 2016.)

(1) Subsection 9.2, title revised to include New Laboratories; new subsections added to better describe new laboratories and new test stands.

ASTM International takes no position respecting the validity of any patent rights asserted in connection with any item mentioned in this standard. Users of this standard are expressly advised that determination of the validity of any such patent rights, and the risk of infringement of such rights, are entirely their own responsibility.

This standard is subject to revision at any time by the responsible technical committee and must be reviewed every five years and if not revised, either reapproved or withdrawn. Your comments are invited either for revision of this standard or for additional standards and should be addressed to ASTM International Headquarters. Your comments will receive careful consideration at a meeting of the responsible technical committee, which you may attend. If you feel that your comments have not received a fair hearing you should make your views known to the ASTM Committee on Standards, at the address shown below.

This standard is copyrighted by ASTM International, 100 Barr Harbor Drive, PO Box C700, West Conshohocken, PA 19428-2959, United States. Individual reprints (single or multiple copies) of this standard may be obtained by contacting ASTM at the above address or at 610-832-9585 (phone), 610-832-9555 (fax), or service@astm.org (e-mail); or through the ASTM website (www.astm.org). Permission rights to photocopy the standard may also be secured from the Copyright Clearance Center, 222 Rosewood Drive, Danvers, MA 01923, Tel: (978) 646-2600; <http://www.copyright.com/>