



Standard Practice for Mechanical Sampling of Coal¹

This standard is issued under the fixed designation D7430; the number immediately following the designation indicates the year of original adoption or, in the case of revision, the year of last revision. A number in parentheses indicates the year of last reappraisal. A superscript epsilon (ϵ) indicates an editorial change since the last revision or reappraisal.

^{ε1} NOTE—“Weight” editorially corrected to “mass” in November 2016.

INTRODUCTION

Analysis data obtained from coal samples are used in establishing price, controlling mine and cleaning plant operations, allocating production costs, and determining plant or component efficiency. The task of obtaining a sample of reasonable mass to represent an entire lot presents a number of problems and emphasizes the necessity for using standard sampling procedures.

Coal is one of the most difficult of materials to sample, varying in composition from noncombustible particles to those which can be burned completely, with all gradations in between. The task is further complicated by the use of the analytical results, the sampling equipment available, the quantity to be represented by the sample, and the degree of precision required.

This practice gives the overall requirements for the collection and within-system preparation of coal samples through the use of mechanical sampling systems utilizing falling stream, cross belt and auger designs. This practice also gives the overall requirements for the bias testing and quality management of mechanical coal sampling systems. The wide varieties of coal-handling facilities preclude the publication of detailed procedures for every sampling situation. The proper collection of the sample involves an understanding and consideration of the physical character of the coal, the number and mass of increments, and the overall precision required.

1. Scope

1.1 This practice is divided into 4 parts A, B, C, and D. These 4 parts represent the previous standards [D7256/D7256M](#), [D4916](#), [D4702](#), and [D6518](#). These 4 standards are the 4 that govern the mechanical sampling of coal and have been combined into one document for the ease of reference of the users of these standards.

1.2 The scope of Part A can be found in Section [4](#).

1.3 The scope of Part B can be found in Section [13](#).

1.4 The scope of Part C can be found in Section [19](#).

1.5 The scope of Part D can be found in Section [32](#).

1.6 *This standard does not purport to address all of the safety concerns, if any, associated with its use. It is the responsibility of the user of this standard to establish appropriate safety and health practices and determine the applicability of regulatory limitations prior to use.* For specific hazard statements, see Sections [7](#), [39.1.6](#), [21](#), [1.4](#), and [38.1.1](#).

2. Referenced Documents

2.1 *ASTM Standards*:²

[D121 Terminology of Coal and Coke](#)

[D2013/D2013M Practice for Preparing Coal Samples for Analysis](#)

[D2234/D2234M Practice for Collection of a Gross Sample of Coal](#)

[D3302 Test Method for Total Moisture in Coal](#)

[D4621 Guide for Quality Management in an Organization That Samples or Tests Coal and Coke \(Withdrawn 2010\)](#)³

[D4702 Practice for Quality Management of Mechanical Coal Sampling Systems \(Withdrawn 2008\)](#)³

[D4749 Test Method for Performing the Sieve Analysis of Coal and Designating Coal Size](#)

[D4916 Practice for Mechanical Auger Sampling \(Withdrawn 2008\)](#)³

[D6518 Practice for Bias Testing a Mechanical Coal Sampling System \(Withdrawn 2008\)](#)³

² For referenced ASTM standards, visit the ASTM website, www.astm.org, or contact ASTM Customer Service at service@astm.org. For *Annual Book of ASTM Standards* volume information, refer to the standard's Document Summary page on the ASTM website.

³ The last approved version of this historical standard is referenced on www.astm.org.

¹ This practice is under the jurisdiction of ASTM Committee [D05](#) on Coal and Coke and is the direct responsibility of Subcommittee [D05.23](#) on Sampling.

Current edition approved Sept. 15, 2016. Published October 2016. Originally approved in 2008. Last previous edition approved in 2016 as D7430–16a. DOI: 10.1520/D7430-16BE01.

[D7256/D7256M Practice for Mechanical Collection and Within-System Preparation of a Gross Sample of Coal from Moving Streams \(Withdrawn 2008\)](#)³

[E105 Practice for Probability Sampling of Materials](#)

[E122 Practice for Calculating Sample Size to Estimate, With Specified Precision, the Average for a Characteristic of a Lot or Process](#)

[E177 Practice for Use of the Terms Precision and Bias in ASTM Test Methods](#)

[E456 Terminology Relating to Quality and Statistics](#)

[E691 Practice for Conducting an Interlaboratory Study to Determine the Precision of a Test Method](#)

3. Terminology

3.1 *Definitions*—Definitions applicable to this practice are listed in Terminology [D121](#).

3.2 *Definitions of Terms Specific to This Standard:*

3.2.1 *accuracy, n*—(1) *generally*, a term used to indicate the reliability of a sample, a measurement, or an observation; (2) *specifically*, a measure of closeness of agreement between an experimental result and the true value. An example is the observed and true sulfur content of a coal consignment. This measurement is affected by chance errors as well as by bias.

3.2.2 *activation interval, n*—*for a falling-stream or cross-belt cutter*, the time from the beginning of movement for taking an increment, to the beginning of movement for taking of the next increment.

3.2.3 *auger increment, n*—the retained portion of one extraction operation of the auger.

3.2.4 *auger sampler, n*—a mechanical device that extracts a columnar sample of coal from a railcar, truck, barge or stockpile and any associated sub-system or within-system components.

3.2.5 *bias, n*—the difference between the population mean of the mechanical sampler test results and the accepted reference value.

3.2.6 *confidence interval, n*—a numeric interval with a lower limit and a higher limit within which the true parameter value is estimated to fall. The confidence interval percentage indicates the percentage of time the true value will fall within the interval if the procedure is continuously repeated.

3.2.7 *consignment, n*—a discrete amount of coal, such as a shipment, a car load, a unit train, or a day's production. A consignment may include more than one lot of coal and may correspond to a specific period of time, such as a sampling period or a billing period.

3.2.8 *correlation, n*—a measure of the linear dependence between paired system and reference measurements. Correlation frequently is expressed by the correlation coefficient, which can take a value from minus one (perfect negative linear relationship) to plus one (perfect positive linear relationship).

3.2.9 *cross-belt sampler, n*—a single sampling machine or component of a mechanical sampling system designed to extract an increment directly from a conveyor belt surface by sweeping a sampling device (cutter) through the material on the conveyor.

3.2.10 *delimitation error, n*—a material error that occurs when all the elements in a cross section of a coal stream do not have an equal probability of being intercepted (captured) by the sampler cutter during increment collection.

3.2.11 *ellipsoidal region, n*—an area that is formed by plane sections of ellipses that are defined by the values selected for the largest tolerable bias of each coal characteristic used in the bias test. The region will be used to determine if the system is biased.

3.2.12 *falling-stream sampler, n*—a single sampling machine or component of a mechanical sampling system designed to extract an increment from a falling stream of coal at the discharge end of a conveyor or chute by moving a sampling device (cutter) through the falling stream of material.

3.2.13 *Hotelling's T^2 test, n*—a statistical test that is used to evaluate multivariate data. It is the multivariate equivalent of the Student's *t*-test.

3.2.14 *largest tolerable bias (LTB), n*—an interval whose upper and lower bounds represent the limits of an acceptable bias.

3.2.15 *mechanical sampling system, n*—a single machine or series of interconnected machines whose purpose is to extract mechanically, or process (divide and reduce), or a combination thereof, a sample of coal.

3.2.16 *paired data set, n*—system and reference values observed on samples collected and compared from the same batch of material.

3.2.17 *precision, n*—a term used to indicate the capability of a person, an instrument, or a method to obtain reproducible results; specifically, a measure of the chance error as expressed by the variance, standard error, or a multiple of the standard error (see Practice [E177](#)).

3.2.18 *reference sample, n*—a sample used in testing of a mechanical sampling system which is comprised of one or more increments collected from the test batch or lot of coal by the stopped belt method as described in Practice [D2234/D2234M](#).

3.2.19 *reject stream, n*—the coal flow within a mechanical sampling system, which occurs at each stage of division, before and after reduction, and is not included in the system sample.

3.2.20 *sampling ratio, n*—the mass of the system sample divided by the mass of the corresponding coal sampled.

3.2.21 *save stream, n*—the coal flow within a mechanical sampling system which occurs at each stage of division, before and after reduction, and after the final stage of division becomes the system sample.

3.2.22 *statistical independence, n*—two sample values are statistically independent if the occurrence of either one in no way affects the probability assigned to the occurrence of the other.

3.2.23 *surrogate sample, n*—a sample, used in the evaluation of a mechanical sampling system, which is comprised of one or more increments collected from a coal stream within the mechanical sampling system in accordance with Practice [D2234/D2234M](#), Conditions "A" or "B." Such a sample may

be considered acceptable for evaluation of a mechanical sampling system's components, excluding the primary cutter, when demonstrated to be equivalent to the reference sample.

3.2.24 *system sample, n*—a sample collected from a test batch or lot of coal by the final stage of a mechanical sampling system.

3.2.25 *unbiased sample (representative sample), n*—a sample free of bias.

3.2.26 *Walsh averages, n*—given a series of observations (differences) x_1, x_2, \dots, x_n , the $n(n + 1)/2$ pair-wise averages given by:

$$(x_i + x_j)/2, 1 \leq i < j \leq n \quad (1)$$

3.2.26.1 *Discussion*—As an example of Walsh averages, assume one has three observations (differences) designated as

x_1, x_2 , and x_3 . There are then a total of $3(4)/2 = 6$ Walsh averages. They are as follows: $x_1, x_2, x_3, (x_1 + x_2)/2, (x_1 + x_3)/2$, and $(x_2 + x_3)/2$.

3.2.27 *Wilcoxon Signed Rank Test, n*—a non-parametric statistical procedure for calculating the point estimate and confidence interval for a sample drawn from a population with symmetric distribution.

3.2.28 *within-system preparation, n*—the process of gross sample preparation carried out mechanically by sequential crushing (reduction) equipment and/or division equipment. It may be carried out by processing increments individually or by batching increments together and processing them together as a group. In any case, within-system preparation is conducted in a manner to minimize moisture changes and without removing the gross sample or its increments from the sampling system.

PART A – MECHANICAL COLLECTION AND WITHIN-SYSTEM PREPARATION OF A GROSS SAMPLE OF COAL FROM MOVING STREAMS
[Old Practice D7256/D7256M]

4. Scope

4.1 *Part A—Mechanical Collection and Within-System Preparation of a Gross Sample of Coal from Moving Streams*—Covers procedures for the mechanical collection of a sample under Classification I-B-1 and I-B-2 (Practice **D2234/D2234M**) and the within-system preparation (reduction and division) of gross samples utilizing various components of the mechanical sampling system.

4.1.1 Part A describes mechanical sampling procedures for coals (1) by size and condition of preparation (for example, mechanically cleaned coal or raw coal), and (2) by sampling characteristics.

4.1.2 The values stated in either SI units or inch-pound units are to be regarded separately as standard. The values stated in each system may not be exact equivalents; therefore, each system shall be used independently of the other. Combining values from the two systems may result in non-conformance with the standard.

5. Summary of Practices

5.1 The general-purpose sampling procedures are intended to provide, in 19 of 20 cases, dry ash results that are within an interval of $\pm 1/10$ of the average dry ash results that would be obtained in hypothetical repeated sampling.

5.2 Special-purpose sampling procedures apply to the sampling of coal when other precision limits are required, or when other constituents are used to specify precision, or for performance tests.

5.3 For coals of known size and condition of preparation, a table (Table 1) is given for the determination of the number and mass of increments required for a gross sample for both general- and special-purpose sampling.

5.4 The only processes of sample division and reduction covered in this document are the use of mechanical sample

dividers for the division of the sample, and mechanical crushing equipment for the reduction of the sample, both of which are within-system components of the mechanical sampling system.

5.5 The procedures appear in the following order:

Test Method	Section
Sampling of Coals Based on Size and Condition of Preparation	10.1
General-Purpose Sampling Procedure	10.1.1
Number and Mass of Increments	10.1.1.2
Number of Gross Samples	10.1.1.4
Special-Purpose Sampling	10.1.2
Number and Mass of Increments	10.1.2.2
Number of Gross Samples	10.1.2.3
Division of the Gross Sample Before Crushing	10.2
Reduction and Division	10.3

6. Significance and Use

6.1 It is intended that this practice be used to provide a sample representative of the coal from which it is collected. Because of the variability of coal and the wide variety of mechanical sampling equipment available, caution should be used in all stages of the sample collection process, the design of sampling system specifications, the equipment procurement and the acceptance testing of installed equipment.

6.2 After removal from the sampling system and further preparation (Practice **D2013/D2013M**), the sample may be analyzed for a number of different parameters. These parameters may define the lot's value, its ability to meet specifications, its environmental impact, as well as other properties.

7. Hazards

7.1 *This standard does not purport to address all of the safety concerns, if any, associated with its use. It is the responsibility of the user of this standard to establish appropriate safety and health practices and determine the applicability of regulatory limitations prior to use.*

7.2 **Warning**—The operation, inspection, maintenance, and cleaning of mechanical sampling equipment involves hazardous operations, conditions, and equipment that may result in serious bodily harm or death. These hazards include, but are not limited to, intermittent operation, remote startup, powerful electrical or hydraulic drives, moving conveyors, crushers, etc.

7.3 It is essential that personnel wear all required personal protective equipment. Personnel should be fully knowledgeable of, and follow, all site-specific safety rules and governmental regulations regarding the equipment in question, including, but not limited to, releasing stored energy, confined spaces, opening of inspection doors during operation, and electrical power lock out/tag out. Be certain to de-energize main power source and not rely on local or control circuits.

TABLE 1 Number and Mass of Increments for General-Purpose Sampling Procedure^A

Top Size	16 mm [5/8 in.]	50 mm [2 in.]	150 mm [6 in.] ^B
Mechanically Cleaned Coal ^C			
Minimum number of increments	15	15	15
Minimum mass of increments, kg [lb]	1 [2]	3 [6]	7 [15]
Raw (Uncleaned Coal) ^C			
Minimum number of increments	35	35	35
Minimum mass of increments, kg [lb]	1 [2]	3 [6]	7 [15]

^A Conditions C and D are not addressed in this standard.
^B For coals above 150-mm [6-in.] top size, the sampling procedure should be mutually agreed upon in advance by all parties concerned.
^C See 9.2.2.

8. Increment Collection Classification

8.1 The type of selection, the conditions under which individual increments are collected, and the method of spacing of increments from the coal consignment or lot are classified according to the following descriptions and Table 1 in Practice D2234/D2234M.

8.2 *Types of Increments*—the only type of selection of increments covered by this document are Type I where there is no human discretion in the selection of the pieces of coal or portions of the coal stream. Type I selection increments generally yield more accurate results than Type II where human discretion is exercised in the selection of specific pieces of coal or of specific portions of the stream, pile, or shipment.

8.3 *Conditions of Increment Collection*—The conditions under which individual increments are collected are the conditions of the main body of coal relative to the portion withdrawn. Only Condition B (Full-Stream Cut), in which a full cross-section cut is removed from a moving stream of coal is covered by this document.

8.4 *Spacing of Increments*—The spacing of increments pertains to the kind of intervals between increments. Two spacing methods are recognized: systematic and random. Systematic spacing is usually preferable.

8.4.1 *Systematic Spacing 1*, in which the movements of individual increment collection are spaced evenly in time or in position over the lot. This practice allows both time-based and mass-based distribution of increments.

8.4.2 *Random Spacing 2*, in which the increments are spaced at random in time or in position over the lot.

9. Organization and Planning of Sampling Operations

9.1 This practice provides definitive procedures for the collection of a gross sample. Parties claiming to use this practice must adhere to the procedures as set out in this practice. If the sampling is not done in accordance with the procedures set out in this practice then that sample may not be suitable for comparison with a sample collected by the procedures described in this practice. Since it may be impracticable or impossible to take another sample of a given lot of coal it is essential that parties agree on sampling procedures prior to undertaking sampling.

9.2 *Selection of Appropriate Sampling Procedure*—Variations in coal-handling facilities make it impossible to publish rigid rules covering every sampling situation in complete and exact detail. Proper sampling involves an understanding and proper consideration of the minimum number and mass of increments, the size consist of the coal, the condition of preparation of the coal, the variability of the constituent sought, and the degree of precision required.

9.2.1 *Number and Mass of Increments*—The number and mass of increments required for a given degree of precision depends upon the variability of the coal. This variability increases with an increase in free impurity. A coal high in inherent impurity and with comparatively little free impurity may exhibit much less variability than a coal with a low inherent impurity and a relatively high proportion of free impurity. For most practical purposes, an increase in the ash

content of a given coal usually indicates an increase in variability. It is imperative that not less than the minimum specified number of increments of not less than the minimum specified mass be collected from the lot.

9.2.2 *Condition of Preparation*—If there is any doubt as to the condition of preparation of the coal (for example, mechanically cleaned coal or raw coal), the number of increments for raw coal shall apply. For the purpose of application of the minimum number of increments in Table 1, mechanically cleaned coal is defined as coal, which has been mechanically cleaned by a specific gravity process in all sieve sizes above No. 100 USA Standard. Similarly, although a coal has been mechanically cleaned it may still show significant variation. For example, the coal may be a blend of two different portions of one seam or a blend of two different seams. In such cases where significant variation is possible, the number of increments should be as specified for raw (uncleaned) coal.

9.3 *Distribution of Increments*—It is essential that the increments be distributed throughout the lot to be sampled. This distribution is related to the entire volume of the lot, not merely its surface or any linear direction through it or over it. If circumstances prevent the sampler from applying this principle, the lot is sampled only in part, and the gross sample is representative only of this part. The spacing of the increments shall be varied if the possibility exists that increment collection may get “in phase” with the sequence of coal variability. Example: routine sampling of commercial coal from a continuous stream (conveyor belt) in which increment collection is automatic and its sequence coincides with the “highs” or “lows” in the content of fines.

9.3.1 *Independence of Cutter Activation Intervals*—Select cutter activation intervals so that cutters do not activate at a set time in relation to the cutter from a previous stage. In addition, the activation interval for any sampling stage shall not be evenly divisible into the previous stage activation interval.

9.4 *Dimensions of Sampling Device*—The opening of the sampling device shall be no less than 3.0 times the nominal top size of the coal but no less than 31.8 mm [1.25 in.]

9.4.1 For systems installed prior to December 31, 2013, the opening of the sampling device may be 2.5 times the nominal top size of the coal but no less than 31.8 mm [1.25 in.].

9.4.2 The sampling device shall be of sufficient capacity to completely retain or entirely pass the increment without spillage at the maximum rate of coal flow.

9.5 *Characteristics and Movement of Sampling Device*—In sampling from moving streams of coal, the sampling device shall be designed to collect each increment with no selective rejection of material by size and with no contamination by nonsample material.

9.5.1 *Falling-Stream Sampler*—In collecting an increment, the falling-stream cutter moves at a constant velocity through the entire cross section of the stream of coal. The mass m , in kg [lb] of material collected in one pass through the stream by a falling-stream cutter, with cutting edges and cutter velocity perpendicular to the stream flow, is calculated from the following equation:

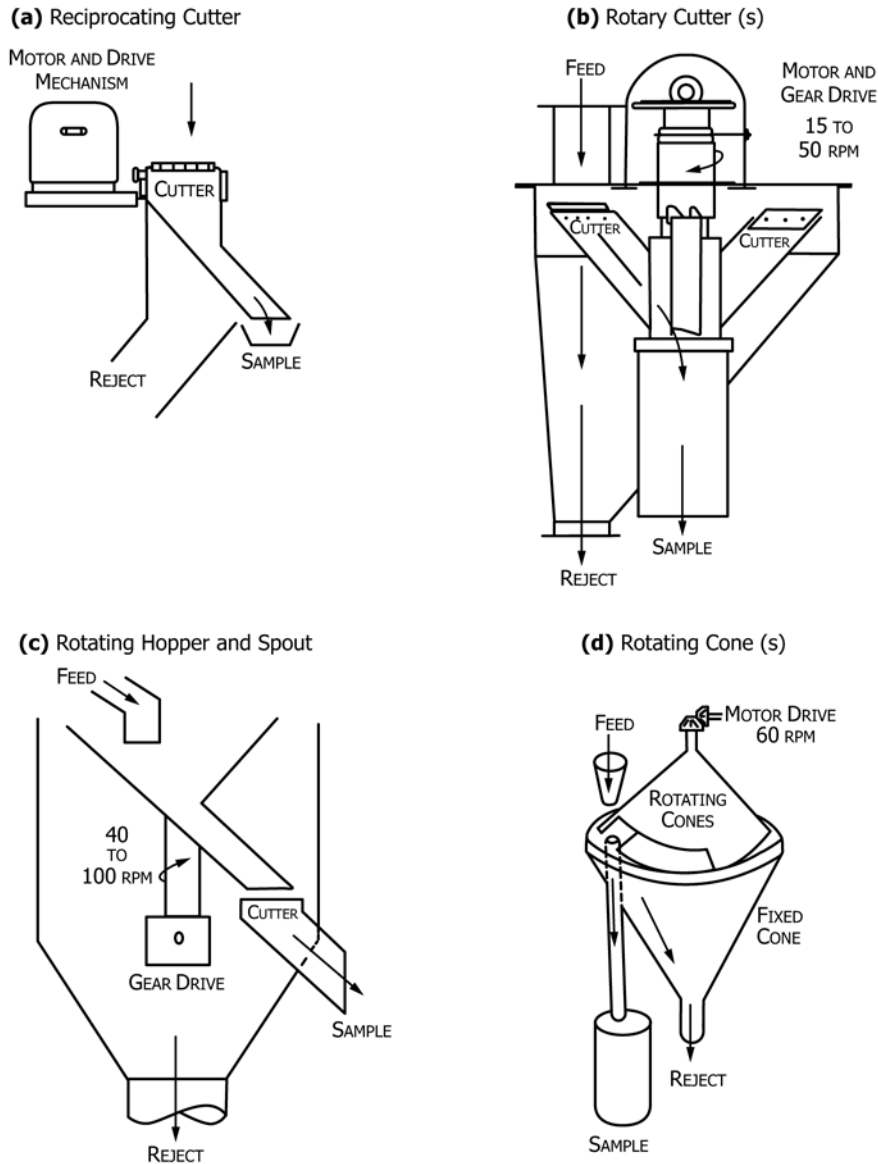

FIG. 1 Mechanical Sample Dividers

$$m = \frac{Cw}{3.6v_c} \left[m = \frac{Cw}{1.8v_c} \right] \quad (2)$$

where:

- C = stream flow rate in Mg/h [ton/h],
- w = tip-to-tip cutter aperture width in mm [in.], and
- v_c = average cutter speed in mm/s [in./s].

NOTE 1—Falling stream cutter speeds of 460 mm/s [18 in./s] or less have been found to produce acceptable results.

NOTE 2—The constant value 3.6 [1.8] in the denominator of Eq 2 converts Mg/h to kg/s [ton/h to lb/s].

NOTE 3—If the falling-stream cutter velocity is not constant as it traverses the material stream, the mass of collected material may not agree with that calculated using Eq 2.

9.5.2 Cross-Belt Sampler—Design and operate the cross-belt cutter at a velocity across the conveyor surface that is high enough to prevent selective rejection of material by size, prevent contamination of the sample with material not collected within the cutter, and avoid mechanical problems due to

damming of conveyed material against the outside of the cutter body as the cutter travels through the stream. Furthermore, assure by design that a complete increment is extracted, and that the arc of travel of the cross-belt cutter closely fits the configuration of the conveyor belt. The mass m , in kg [lb], of material collected in one pass through the moving stream by a cutter with cutting edges and cutter velocity perpendicular to the stream flow is calculated from the following equation:

$$m = \frac{Cw}{3.6v_b} \left[m = \frac{Cw}{1.8v_b} \right] \quad (3)$$

where:

- C = stream flow rate in Mg/h [ton/h],
- w = tip-to-tip cutter aperture width in mm [in.], and
- v_b = conveyor belt speed in mm/s [in./s].

NOTE 4—The constant value 3.6 [1.8] in the denominator of Eq 3 converts Mg/h to kg/s [ton/h to lb/s].

NOTE 5—To avoid mechanical problems and spillage and to assure

correct sample delimitation the higher ratio of cutter speed to belt speed the better. Ratios of cutter speed to belt speed of 1.5 or greater have been found to produce acceptable results.

9.6 There shall be no structural member or other impediment within a cutter body that impedes either sample collection or sample discharge.

9.7 *Preservation of Moisture*—The increments obtained during the sampling period shall be protected from changes in composition as a result of exposure to rain, snow, wind, sun, contact with absorbent materials, and extremes of temperature. The circulation of air through equipment must be reduced to a minimum to prevent both loss of fines and moisture. Samples in which moisture content is important shall be protected from excessive air flow and then shall be stored in moisture-tight containers. Metal cans with airtight lids, or heavy vapor-impervious bags, properly sealed, are satisfactory for this purpose.

9.8 *Contamination*—The sampling arrangement shall be planned so that contamination of the increments with foreign material or unrelated coal does not create bias of practical consequence.

9.9 *Mechanical System Features*—It is essential that mechanized systems as a whole, including sampling machines, chutes, feed conveyors, crushers and other devices, be self-cleaning and non-clogging and be designed and operated in a manner that will facilitate routine inspection and maintenance.

9.10 *Personnel*—Because of the many variations in the conditions under which coal must be sampled, and in the nature of the material being sampled, it is essential that the samples be collected under the direct supervision of a person qualified by training and experience for this responsibility.

9.11 *Criteria of Satisfactory Performance*—A satisfactory arrangement for mechanical collection and within-system preparation of a gross sample of coal from a moving stream must properly apply the principles of systematic sampling. Use the instructions in Part A to collect increments from the lot being sampled either at random or even intervals in such a manner that the quality and size consist of each part of the lot has an equal probability of being represented in the sample. Use the instructions in Part C to evaluate the mechanical performance of the system as a matter of routine, especially in regards to monitoring sampling ratios and system inspections. Use the instructions in Part D to bias test the system using prescribed procedures and methods.

9.12 *Relative Location of Sampling and Weighing*—It is preferable that coal be weighed and sampled at the same time. If there is a lapse in time between these two events, consideration should be given by both the purchaser and the seller to changes in moisture during this interval and the consequent shift in relationship of moisture to the true quality of the coal at the instant when ownership of the coal transfers from one to the other.

10. Procedures

10.1 *Sampling of Coals Based on Size and Condition of Preparation:*

10.1.1 *General-Purpose Sampling:*

10.1.1.1 Where probability sampling is employed, the general-purpose sampling procedures are intended to provide, in 19 of 20 cases, dry ash results that are within the interval of $\pm 1/10$ of the average dry ash results that would be obtained in hypothetical repeated sampling.

10.1.1.2 *Number and Mass of Increments*—Obtain the number and mass of increments as specified in **Table 1** except as provided in 10.1.1.5(2). Determine the minimum number of increments from the condition of preparation, and determine the minimum mass of each increment from the top size of the coal. Classify the coals to be sampled according to the general purpose procedure into three groups by top size. Further classify each of these groups into two subgroups in accordance with the condition of preparation. These classifications are shown in **Table 1**.

10.1.1.3 Variations in construction of the sampling device and flow, structure, or size consist of the coal may make it impracticable to collect increments as small as the minimum mass specified in **Table 1**. In such cases, collect an increment of greater mass. However, do not reduce the minimum number of increments, regardless of large excesses of individual increment masses. **Table 1** lists the absolute minimum number of increments for general-purpose sampling which may not be reduced except as specified in 10.1.1.5(2). Other considerations may make it advisable or necessary to increase this number of increments.

10.1.1.4 *Number of Gross Samples*—Under the general-purpose sampling procedure, for quantities up to approximately 1000 Mg [1000 tons] it is recommended that one gross sample represent the lot. Take this gross sample in accordance with the requirements prescribed in **Table 1**.

10.1.1.5 For quantities over 1000 Mg [1000 tons], use any of the following alternatives:

(1) Take one gross sample for the lot and analyze it to represent the quality of the lot. Collect the number of increments N calculated from **Eq 4**:

$$N = K \sqrt{\frac{L}{1000}} \quad (4)$$

where:

L = number of Mg [tons], and

K = 15.7 [15] for mechanically cleaned coal or 36.7 [35] for raw coal.

(2) Divide the lot into sub-lots and take a separate gross sample from each sub-lot. Use **Eq 4** to determine the minimum number of increments for each sub-lot, with L being the sub-lot quantity. Mass-average the analyses of the sub-lot samples to represent the quality of the original lot.

10.1.1.6 The maximum lot size shall be chosen by mutual agreement between the seller and the buyer of the coal, with each party taking into account the risks associated with the choice. Potential consequences include:

(1) Large samples requiring excessive off-line preparation steps can result in sampling moisture losses.

(2) No quality information is obtained on within-lot variability. Lot sizes generally should not exceed quantities for which critical quality levels apply in use of the coal.

(3) When a given quantity of coal that might be represented by a single lot is divided into multiple sub-lots, the imprecision of the reported quality for that given quantity is reduced. For a given quantity, the component of imprecision due to sample preparation and analysis is reduced by $1/\sqrt{m}$ where m is the number of sub-lots.

10.1.2 *Special-Purpose Sampling:*

10.1.2.1 This special-purpose sampling procedure shall apply to the sampling of coal when increased precision is required, and the only knowledge of the coal is its top size and conditions of preparation.

10.1.2.2 *Number and Mass of Increments*—Take the same number and mass of increments per gross sample as specified in [Table 1](#), or as specified in [10.1.1.5\(2\)](#).

10.1.2.3 *Number of Gross Samples*—To obtain increased precision for the final result for a given consignment, increase the number of gross samples collected from that consignment and analyze each gross sample separately, reporting the average of results. To reduce errors to one half, that is, to “double” the precision, take four times as many gross samples. Similarly, to reduce errors to one third, to “triple” the precision, take nine times as many gross samples.

10.1.3 *Sampling for Total Moisture Only:*

10.1.3.1 The increments as established in [Table 1](#) for mechanically cleaned coal are deemed adequate for general purpose sampling for total moisture.

10.2 *Division of the Gross Sample Before Crushing:*

10.2.1 Large primary increments may be divided in quantity before crushing by secondary sampling. In the case of dividing a primary increment before crushing, the minimum increment mass must meet the mass specified in [Table 1](#) for the top size listed.

10.2.1.1 If each primary increment is reduced in quantity by secondary sampling, take at least six secondary increments from each uncrushed primary increment. The method of collection of secondary increments must be proved to be free from bias. In no case shall the mass of a secondary increment be less than shown in the schedule of [Table 1](#).

10.3 *Reduction and Division:*

10.3.1 Reduce the gross or divided sample in stages and divide by suitable mechanical sample dividers (see [10.4.2](#)) to quantities not less than those shown in [Table 1](#) of Practice [D2013/D2013M](#).

10.3.2 Mechanical division of the sample consists of automatically collecting a large number of increments of the properly reduced sample. Distribute this large number of increments equally throughout the entire discharge from the sample crusher because crushers can introduce appreciable segregation. At each stage of division, take at least 60 increments.

NOTE 6—Reduction and division of the mechanical samples that do not involve within-system components of the mechanical sampling system are

not covered by this document but governed by Practice [D2013/D2013M](#).

NOTE 7—It is recommended that, in the case of mechanical division in which an increment is not thoroughly mixed with other increments before division, a portion of each increment be collected by the subsequent stage increment collection process.

10.4 *Reduction and Division Apparatus:*

10.4.1 *Crushers or Grinders*—Jaw, cone, or rotary crusher; hammer mill; roll; or other suitable crusher to reduce the sample. Design and operate crushers in a manner to minimize the effect of induced air circulation and thus the potential for drying the coal.

10.4.1.1 *Hammer Mill*—Completely enclosed to avoid loss of dust or moisture.

10.4.2 *Sample Dividers: Mechanical*—A mechanical sample divider using a reciprocating or rotating cutter, a rotating hopper and spout, a rotating slotted cone, a reciprocating hopper and fixed cutter, bucket cutter with either bottom dump or inverting discharge, slotted belt, rotary disk divider, mechanical stopped or moving belt sweeper, or other acceptable devices for dividing the sample. Typical mechanical sample dividers are shown in [Fig. 1](#). These illustrate various designs, but other acceptable designs are available.

11. Maintenance of Mechanical Sampling Equipment

11.1 Design mechanical sampling equipment to facilitate inspection, cleaning and maintenance.

11.1.1 Ensure that hatches and doors are located to provide easy access to key areas of the sampler such as: (a) cutters in their parked positions, (b) high wear items like crusher components, belt wipers or the wiping edge of cross-belt cutters, and (c) points of potential pluggage within the system; etc.

11.1.2 Enable hatches and doors to be quickly and easily opened, closed and secured, and include seals that make them air and dust tight.

11.1.3 Provide adequate access to the sampler (for example using permanent walkways, ladders, platforms, etc.) so that personnel can work effectively on and around the sampling equipment.

11.2 Wear of mechanical components may eventually cause a system, which had originally been checked satisfactorily for bias, to produce biased samples. Inspect mechanical systems frequently and in accordance with a planned maintenance scheme in order to ensure continuous reliable operation by detecting and repairing system components that have undergone wear beyond a critical level or are broken.

12. Precision and Bias

12.1 The precision of the general-purpose sampling procedure, based on size and condition of preparation, is stated in [10.1.1.1](#). If a different precision is required, see [10.1.2](#).

12.2 Mechanical sampling systems are tested for bias using the procedures of Part D.

PART B – MECHANICAL AUGER SAMPLING
[Old Practice D4916]

13. Scope

13.1 *Part B—Mechanical Auger Sampling*—Describes procedures for the collection of an increment, partial sample, or gross sample of material using mechanical augers. Reduction and division of the material by mechanical equipment at the auger is also covered. Further manual or mechanical reduction or division of the material elsewhere shall be performed in accordance with Practice **D2013/D2013M**.

13.1.1 The values stated in either SI units or inch-pound units are to be regarded separately as standard. The values stated in each system may not be exact equivalents; therefore, each system shall be used independently of the other. Combining values from the two systems may result in non-conformance with the standard.

14. Summary of Practices

14.1 A sample of coal is extracted from a stationary load contained within a railcar(s), truck(s), or barge(s) by inserting an auger into the vehicle in a vertical manner to extract a columnar sample of coal from the vehicle. Protect the coal collected by the auger, or processed by additional sampling components, from moisture change and contamination by placing it into containers and sealing them.

15. Significance and Use

15.1 Auger sampling systems may be used to extract samples from trucks, railcars, barges, or static compacted stockpiles where the use of a full-stream mechanical sampling system may be impractical. The samples obtained from these systems can be used to establish the materials' commercial value or constituents for quality control purposes at the shipping or receiving location of the interested parties in the transaction. The utilization of an auger system and procedures for collecting coal samples for subsequent analysis should be agreed upon by all parties concerned. Compacted stockpiles should be no higher than the length of the auger sampler. Otherwise, the deeper areas of the stockpile cannot be sampled.

16. Hazards

16.1 *This standard does not purport to address all of the safety concerns, if any, associated with its use. It is the responsibility of the user of this standard to establish appropriate safety and health practices and determine the applicability of regulatory limitations prior to use.*

16.2 **Warning**—The operation, inspection, maintenance, and cleaning of mechanical sampling equipment involves hazardous operations, conditions, and equipment that may result in serious bodily harm or death. These hazards include, but are not limited to, intermittent operation, remote startup, powerful electrical or hydraulic drives, moving conveyors, crushers, etc.

16.3 It is essential that personnel wear all required personal protective equipment. Personnel should be fully knowledgeable of, and follow, all site-specific safety rules and governmental regulations regarding the equipment in question, including, but not limited to, releasing stored energy, confined spaces, opening of inspection doors during operation, and electrical power lock out/tag out. Be certain to de-energize main power source and not rely on local or control circuits.

17. Organization and Planning of Sampling Operations

17.1 *General Considerations*—Mechanical auger sampling is designated as Condition D, Stationary Coal Sampling. When using augers to sample, the material taken may only be representative to the depth sampled. In addition, the parameters such as top size, degree of preparation, degree of material segregation, and pattern of auger placement should also be considered.

17.2 *Consideration of Top Size*—Designs of mechanical sampling augers vary from high-powered augers with cutter bits drilling through the coal to be sampled, to low-powered augers designed to sample loosely compacted coal. The clearance in the auger assembly and flights should be sufficient to allow passage of the largest top size in the lot of coal to be sampled. If the top size of coal makes the auger size impractical, the auger should be designed to cut through or break up the lumps of coal.

17.3 *Consideration for Number of Auger Increments*—The number of increments required should be based on the lot size and degree of material preparation. For purposes of this practice, the degree of preparation is divided into two categories, that is, raw and mechanically cleaned. The lot size may be determined by factors such as prior contractual agreements, operational restrictions, coal storage capabilities, and coal transportation methods such as rail car, truck, or barge. Determine the number of increments required to represent the lot by following **Eq 4** in **10.1.1.5**.

17.3.1 Determine recommendations for the number of auger increments per vehicle by the following formula:

$$N_3 = N_2 \times b/a \tag{5}$$

where:

- N_2 = number of increments required,
- N_3 = number of increments per vehicle,
- a = lot size, Mg [tons], and
- b = amount of material per vehicle, Mg [tons].

If N_3 is greater than one, round it off to the nearest whole number. If N_3 is less than one, it is recommended that one increment be taken from each vehicle.

17.3.2 However, if operational considerations make the application of these procedures impractical, the following suggestions may be considered:

17.3.2.1 *Example 1*—When more than one increment per vehicle is recommended but deemed impractical, then take as

many increments as possible, but never less than one increment per vehicle. It should be realized that any reduction in the number of increments could reduce the precision of the final sample. In any case, obtain the same number of increments from each vehicle within the lot.

17.3.2.2 *Example 2*—When N_3 is less than one and one increment per vehicle has not been selected as practical, then use the following procedure: take the reciprocal of N_3 (that is, calculate $1/N_3$) and round off this value to the nearest whole number. This is now the number of vehicles per increment. Next, space the increments over the number of vehicles either systematically or randomly while noting these precautions; although systematic spacing (for example, one increment every second vehicle for 100 vehicles) may be preferred in other sampling practices, practical consideration must be given to the phenomena of cyclical variability which is common in this type of sampling operation. If systematic spacing is not chosen, random spacing (for example, distributing the 50 increments randomly over the next 100 vehicles) must ensure the elimination of human discretion. This may be done by preplanning and the use of various random-number generator schemes.

17.3.2.3 *Example 3*—When sampling a leveled, compacted stockpile, consideration must be given to the number of increments necessary to represent the lot. It is recommended that a stockpile be divided into lots of not over 45 Mg [50 tons]. The number of increments required per lot size would be in accordance with 17.3 of this practice.

17.4 *Considerations for Auger Placement Patterns and Increment Collections*—The ease of extracting the auger increments from various portions within the vehicle will be predicated upon the auger design, vehicle type, and support facility limitations. However, it is recommended that a random sampling location pattern be developed to maximize the number of locations from where the auger can extract an increment. Human discretion should be minimized with respect to auger placement to the extent possible. When the lot to be sampled is comprised of vehicles having different cargo capacities, the user should be aware that the auger increment extracted may result in a disproportionate representation of sample from certain vehicles within the lot.

17.4.1 *Sampling Leveled Compacted Stockpiles*—The shape of the area to be represented by each gross sample determines the grid pattern for increment collection. Increments are to be collected at the intersection of the grid pattern. Each grid section should represent equal area as near as possible.

17.4.1.1 The grid pattern must include the slope of the pile. Also, the slope of the pile may not be as compacted as the top. Take care to ensure adequate sampling of the slope.

17.4.2 *Stockpiles of Less than 3 m [10 ft] Height*—The preferred device to be utilized on stockpiles of less than 3 m [10 ft] height is a mobile, mechanical, truck-mounted auger. This device will penetrate to the pile base.

17.4.2.1 The use of an auger to sample a stockpile must be considered a Class D Method. It should be used only if a higher method is not possible. Because of auger design, all of the fine material from the bottom of a pile may not be collected. All parties should agree on the use of the auger method before it is used.

17.4.3 *Stockpiles of Greater than 3 m [10 ft] Height*—The preferred device to be utilized on a stockpile of over 3 m [10 ft] height is a hollow-stem auger and split-spoon sampler that will allow the deepest penetration into the pile and identify the base. If the hollow-stem auger and split-spoon sampler is used, the option of producing a three-dimensional grid exists. In a three-dimensional grid pattern, each grid must represent equal area. Increments are to be collected at the intersection of the grid pattern.

17.4.4 *Stockpile Sampling Records*—Sampling technicians should keep a written log with notations of all the conditions encountered during increment collection. Items to be noted may include size of the stockpile, size-segregation patterns, general configuration of the stockpile, weather conditions including the ambient temperature, degree of compaction of the stockpile, perimeter conditions of the pile, degree of contamination, and visual appearance of the material.

17.5 *Preservation of Moisture*—The increments obtained during the sampling period shall be protected from changes in composition due to exposure to rain, snow, wind, sun, contact with absorbent materials, and extremes of temperature. The circulation of air through equipment must be reduced to a minimum to prevent loss of both fines and moisture. Samples in which moisture content is important shall be protected from excessive airflow and stored in moisture-tight containers. Containers with airtight lids and heavy gage vapor-impervious bags tightly sealed are satisfactory for this purpose.

17.6 *Contamination*—The sampling arrangement shall be planned so that contamination of the increments with foreign material or unrelated coal is avoided.

17.7 *Mechanical System Features*—It is essential that the entire auger system, that is, cutters, chutes, conveyors, crushers, be self-cleaning and be designed in a manner that will minimize the need for maintenance.

17.8 *Personnel*—Because of the many variations in the conditions under which coal must be sampled, it is essential that the samples be collected under the direct supervision of a person qualified by training and experience for this responsibility. Where human discretion is employed in collecting the increments, it is essential that the samples be collected by a trained and experienced person or under the direct supervision of such a person.

17.9 *Relative Location of Sampling and Weighing*—It is preferable that coal be weighed and sampled at relatively the same time. If there is a lapse in time between these two events, consideration should be given by both the purchaser and seller to changes in moisture during this interval and the consequent shift in the relationship of moisture to the quality of the coal at the time when ownership transfers from seller to buyer.

17.10 *Reduction and Mechanical Division of the Auger Increments:*

17.10.1 *Division of Auger Increments Before Crushing:*

17.10.1.1 *Number of Increments*—If each retained increment is reduced in quantity by secondary sampling, take at least six secondary increments from each retained auger increment. This method of collection of secondary increments should be proven to be free from bias.

17.10.1.2 *Opening of Sampling Device*—The opening of the sampling device shall be at least 2½ to 3 times the top size of coal but in no case less than 31.8 mm [1¼ in.].

17.10.1.3 *Speed of Sampling Device*—To prevent segregation and rejection caused by disturbance of the coal stream, practical evidence indicates that the velocity with which the cutting instrument travels through the stream should not exceed 457 mm/s [18 in./s]. However, if greater cutter speeds are used, it is desirable to verify that they are free of bias under the normal range of expected conditions.

17.10.2 *Division of Auger Increment After Crushing:*

17.10.2.1 *Number of Increments*—Because of the various methods of loading and transporting material, stratification and segregation of material within the auger barrel may exist. This problem may be intensified by the nonuniformity in size of the crushed sample. It is recommended that a minimum of three secondary crushed increments per auger increment be collected and spaced evenly throughout the extracted auger increment.

17.10.2.2 In most auger installations involving on-line crushing, the sample is normally reduced in size to 10 mm [¾ in.] or less. Regardless of the final sample size, the cutter opening shall be no less than 31.8 mm [1¼ in.] in width. A cutter opening greater than 31.8 mm may be required in some cases to prevent bridging of the cutter opening, and consideration should be given to the material size, moisture content, coal-flow characteristics, and velocity at the cutter. In those cases where the auger increment is crushed to a larger top size than 10 mm, the cutter opening shall not be less than 2½ to 3 times the material top size.

17.10.2.3 *Speed of Sampling Device (After Crushing)*—To prevent segregation and rejection caused by disturbance of the coal stream, practical evidence indicates that the velocity with which the cutting instrument travels through the stream should

not exceed 457 mm/s [18 in./s]. However, if greater cutter speeds are used, it is desirable to verify that they are free of bias under the normal range of expected conditions. Depending upon the sampler design, speeds slower than 457 mm/s may be desirable, especially when the cutter opening is set at the 38.1-mm dimension. Consideration should be given to the material feed angles to the sampler, particle size, moisture, flow characteristics, and flow rate to ensure nonpreferential extraction.

17.10.2.4 *Size of Increment*—In consideration of the individual increment masses, each increment should be of a mass sufficient to overcome internal factors such as airflow within the chutework, friction on the chute surfaces, and other factors affecting potential moisture losses. It is recommended that each secondary increment weigh a minimum of 50 g [1.8 oz].

17.11 *Criteria of Satisfactory Performance*—A satisfactory mechanical auger sampling arrangement must properly apply the principles of systematic sampling. Use the instructions in Part B to collect increments from the lot being sampled at random intervals in such a manner that the quality and size consist of each part of the lot has an equal probability of being represented in the sample. Use the instructions in Part C to evaluate the mechanical performance of the system as a matter of routine, especially in regards to system inspections. Use the instructions in Part D to bias test the system using prescribed procedures and methods.

18. Precision and Bias

18.1 At this time, sufficient performance data with respect to precision and bias is not available to establish statements in regard to the performance range for all of the auger designs and operating conditions.

PART C – QUALITY MANAGEMENT OF MECHANICAL COAL SAMPLING SYSTEMS [Old Practice **D4702**]

19. Scope

19.1 *Part C—Quality Management of Mechanical Coal Sampling Systems*—Is applicable to the quality management of cross-belt, falling stream, and auger sampling systems.

19.1.1 Spacing of increments pertains to the kind of interval between increments. Intervals can be defined in quantitative terms, such as units of time or mass, or in terms of position over the lot.

19.1.2 *Spacing of Increments for Cross-Belt and Falling Stream Samplers*—Cross-belt and falling stream type mechanical sampling systems take increments based on time, either at fixed time intervals or at random times during a fixed time strata. Some falling stream samplers can take increments based on equal mass of coal sampled as determined by scales. The sections of this practice that pertain to cross-belt and falling stream samplers describe procedures for only time-based sampling systems. This time-based inspection guideline will satisfy most criteria for mass-based or combination mass-based and time-based sampling systems. If there are items that are not covered, the inspector should refer to the manufacturer's literature.

19.1.3 *Spacing of Increments for Auger Sampling*—The spacing of increments collected by auger sampling systems is defined in terms of position over the lot.

19.1.4 It is essential that the inspector have the documentation listed in Section 2 of this practice when conducting an inspection.

19.1.5 The values stated in either SI units or inch-pound units are to be regarded separately as standard. The values stated in each system may not be exact equivalents; therefore, each system shall be used independently of the other. Combining values from the two systems may result in non-conformance with the standard.

20. Significance and Use

20.1 This practice addresses quality assurance criteria for operation of a mechanical coal-sampling system in accordance with Part A, Practice **D2013/D2013M**, and Part B. It provides recommendations for performance monitoring, inspection, and maintenance, which are necessary in maintaining a sampling system's capability to consistently obtain a representative sample.

21. Hazards

21.1 *This standard does not purport to address all of the safety concerns, if any, associated with its use. It is the responsibility of the user of this standard to establish appropriate safety and health practices and determine the applicability of regulatory limitations prior to use.*

21.2 **Warning**—The operation, inspection, maintenance, and cleaning of mechanical sampling equipment involves hazardous operations, conditions, and equipment that may result in serious bodily harm or death. These hazards include,

but are not limited to, intermittent operation, remote startup, powerful electrical or hydraulic drives, moving conveyors, crushers, etc.

21.3 It is essential that personnel wear all required personal protective equipment. Personnel should be fully knowledgeable of, and follow, all site-specific safety rules and governmental regulations regarding the equipment in question, including, but not limited to, releasing stored energy, confined spaces, opening of inspection doors during operation, and electrical power lock out/tag out. Be certain to de-energize main power source and not rely on local or control circuits.

22. Monitoring Sampling Ratio

22.1 Monitoring sampling ratios with a control chart is an important part of the quality management system of mechanical coal sampling. Trend analysis, descriptive statistics (especially the coefficient of variation), and comparisons to the design sampling ratio can all be used to indicate:

(1) An out-of-control condition,

(2) Unintended change in the operational components within the system that affect the system sample mass,

(3) Or both.

Refer to **Appendix X2** for further details on monitoring sampling ratios.

23. Assessing the Organization and Planning of Sampling Operations

23.1 It is recommended that inspection personnel meet with the appropriate personnel responsible for the mechanical sampling system, on all visits, to discuss the organization and planning of sampling operations. ASTM standards provide for the use of various options. Examples and references are given in **23.1.1** and **23.1.2** as follows:

23.1.1 *Cross-Belt and Falling-Stream Samplers*—The number of primary increments for the gross sample collected by cross-belt and falling-stream systems can be determined from **10.1.1.4** and **10.1.1.5** of Part A.

23.1.2 *Auger Sampling*—Considerations for the number of auger increments per lot and per vehicle are discussed in the Consideration for Number of Auger Increments section (**17.3**) of Part B.

23.2 Inspection personnel should refer to the sections of Part A and Part B referenced in **23.2.1** and **23.2.2** of this practice when assessing the conformance of the organization and planning of cross-belt, falling-stream, and auger sampling operations as follows:

23.2.1 *Planning of Cross-Belt or Falling-Stream Sampling Operations*—When assessing the conformance of the organization and planning of sampling operations for a specific cross-belt or falling-stream mechanical sampling system, the inspector should use Section 9, Organization and Planning of Sampling Operations, of Part A which covers the items that would be used in evaluating the sampling plan. Items covered

are: Precautions, Selection of Appropriate Sampling Procedure, Number and Mass of Increments, Increment Collection Method to be Used, Distribution of Increments, Dimensions of Sampling Device, Movement of Sampling Device, Preservation of Moisture, Contamination, Mechanical System Features, Personnel, Criteria of Satisfactory Performance, and Relative Location of Sampling and Weighing.

23.2.2 *Planning of Auger Sampling Operations*—When assessing the conformance of the organization and planning of sampling operations for a specific auger sampling system, use Section 17, Organization and Planning of Sampling Operations, of Part B, which covers the following items: Precautions, Consideration of Top Size, Consideration for Number of Auger Increments, Considerations for Auger Placement Patterns and Increment Collections, Preservation of Moisture, Contamination, Mechanical System Features, Personnel, Relative Location of Sampling and Weighing, and Reduction and Mechanical Division of the Auger Increments.

24. General Observations of Coal Stream Variability as Related to Primary Increment Collection by Falling-Stream and Cross-Belt Samplers

24.1 The entire coal-handling system up to the cross-belt or falling-stream mechanical sampler should be examined to determine if any unloading, storage, or reclaiming procedures produce a cyclical pattern which could cause the increment collection to get *in phase* with the sequence of coal variability. Variations in the physical characteristics, such as particle-size distribution, surface moisture, extraneous matter, and oversized material, can become cyclical and even could be in phase with the time-based increment collection. When such cyclical variations occur in the coal stream, the source of the variations should be investigated to determine the practicability of eliminating the variations. If there is no practical way to eliminate the variations, then either the number of primary increments or the primary cutter velocity or both shall be varied.

NOTE 8—The number of primary increments should be varied by adjusting the time interval between primary cuts so that the period of cyclic variation is not evenly divisible by the number of primary cuts per period or by using a method of random collection of primary increments.

25. General Observations of Auger Placement

25.1 At a minimum, the inspector should examine the following two aspects of the placement of the auger over the surface of the coal being sampled: (1) human discretion in placement of the auger over the surface of the coal in the vehicle(s) and (2) the pattern of auger placement from vehicle to vehicle for lots comprised of more than one vehicle load of coal.

25.1.1 *Human Discretion*—To the extent possible, human discretion should be minimized with respect to auger placement over the surface of the coal in the vehicle(s). The inspector should examine the placement of the auger over the surface of the coal in at least one vehicle to determine that human discretion is minimized in positioning the auger.

25.1.2 *Auger Placement Patterns*—The inspector should refer to the Considerations for Auger Placement Patterns and

Increment Collections section (17.4) of Part B in regard to considerations for auger placement patterns and increment collections.

26. Inspection of the Primary Sampler in Time-Based Cross-Belt or Falling-Stream Sampling Systems

26.1 It is suggested that the inspector start at the primary cross-belt or falling-stream sampler and follow through the system to the final *online* sample collection point. The inspection should be made with and without coal running through the system.

26.2 The following items should be checked for the primary sampler:

26.2.1 Check the cross-belt or falling-stream cutter opening to determine that it complies with the Dimensions of Sampling Device section (9.4) of Part A.

26.2.2 Sufficient inspection doors shall be available to observe that the primary cross-belt or falling-stream cutter cuts the full stream of coal.

26.2.3 Observe, or if necessary, measure, the movement of the primary cross-belt or falling-stream cutter to verify uniform speed while in the coal stream.

26.2.4 Determine the velocity of the cross-belt or falling-stream cutter by dividing the distance the cutter travels while in the coal stream by the time required for traveling that distance. Make the velocity check for both directions if applicable. See the Characteristics and Movement of Sampling Device section (9.5) of Part A for recommendations.

26.2.5 For cross-belt or falling-stream systems, it should be determined that the proper number of primary increments are taken to satisfy the requirements of the Sampling of Coals Based on Size and Condition of Preparation or the Sampling of Coals Based on Known Sampling Characteristics of Part A. It should be determined that the time interval between primary cuts is correct to assure that the minimum number of increments are collected for the lot of coal being sampled during the inspection based on maximum attainable feed rates.

26.2.6 The inspector shall determine that the falling-stream sample cutter is parked out of the stream of coal in the *at rest* position and that no coal is entering the cutter opening. There shall be no holes in the baffle plate, dust doors, or seals that may cause leaking of the sample into the primary sample hopper.

26.2.7 For cross-belt and falling-stream systems, the minimum mass of the primary sample increment shall be as specified in Table 1 of Part A.

27. Inspection of Augers

27.1 The following items should be checked for the auger:

27.1.1 Check the auger assembly to determine that it complies with the Consideration of Top Size section (17.2) of Part B.

27.1.2 Check the auger to determine that it extracts a vertical increment of coal extending from the surface to as close as practicable to the bottom of the transport vehicle.

27.1.3 For auger sampling systems, it should be determined that the proper number of primary (auger) increments are taken

to satisfy the requirements of the Consideration for the Number of Auger Increments section (17.3) of Part B.

28. Criteria for Secondary Sampler Operation

28.1 The items discussed in 28.2 – 28.6 of this practice apply regardless of whether the primary increments are collected by cross-belt, falling-stream, or auger sampling devices. References are provided to applicable sections of Part A and Part B.

28.2 The following items should be checked for the primary sample hopper:

28.2.1 The primary sample hopper shall be enclosed to minimize moisture change and shall be of adequate size to hold the amount of primary increments collected.

28.3 The feeder from the primary sample hopper to a secondary sampler or to a sample crusher should distribute the coal flow over a long enough time interval so the required number of secondary increments are collected or to minimize pluggage of the sample crusher.

28.3.1 The feeder shall be enclosed to minimize moisture change and designed to prevent spillage.

28.3.2 A primary belt feeder or conveyor or both shall be provided with an effective wiper designed to discharge the wipings into the next unit of the mechanical sampling system, thus avoiding loss of sample.

28.4 If the primary feeder discharges the primary increment directly into a secondary sampler without intermediate crushing, the inspector should check the following items:

28.4.1 A minimum of six secondary increments shall be collected from each uncrushed primary increment as specified in 10.2.1.1 of Part A and 17.10.1.1 of Part B. The six or more secondary increments should be equally spaced throughout the entire flow of the primary increment.

28.4.2 Each secondary increment must conform to the minimum increment mass specified in Table 1 of Part A for nominal top size.

28.4.3 Secondary cutter velocity must be uniform across the entire coal stream and conform to the recommendations of the Increment Collection Method to be Used and the Characteristics and Movement of Sampling Device sections (9.2.1 and 9.5) of Part A, and the Speed of Sampling Device section (17.10.1.3) of Part B.

NOTE 9—The use of a stopwatch may not provide sufficient accuracy for short travel.

28.4.4 Cutter opening shall conform to the recommendations of the Dimensions of Sampling Device section (9.4) of Part A, and the Opening of Sampling Device section (17.10.1.2) of Part B.

28.4.5 The secondary cutter is out of the coal stream when in the *at rest* position. See 26.2.6 of this practice for precautions against leakage.

28.5 The sample crusher is fed from either the primary or secondary sampler by a feeder. The requirements and criteria for the secondary feeder are the same as for the primary feeder as described in 28.3 of this practice.

28.6 The sampling system can be designed to crush to an intermediate coal size, which in turn would be resampled before it would be fed to a secondary sampler crusher or, as is done in many sampling systems, to crush to the final sample size.

28.6.1 The sample crusher shall produce a product as required by design and shall be ample in size so as to be essentially free of plugging.

28.6.2 Performance of the sample crusher in achieving the designed particle-size distribution can be determined from the procedures and equipment prescribed in Test Method D4749.

28.6.3 As specified in the Preservation of Moisture section of Part A, the flow of air through the sampling system shall be minimized. (Also see the Preservation of Moisture section (17.5) of Part B.) There are numerous devices for minimizing air windage in a sampling system, such as a pressure equalizing pipe connecting inlet to outlet of the crusher, air curtains, or baffles, and so forth.

29. Criteria for Tertiary or Final Sampler Operation

29.1 The criteria for tertiary or final sampler operation discussed in Section 28 of this practice apply regardless of whether the primary increments are collected by cross-belt, falling-stream, or auger sampling devices. References are provided to applicable sections of Part A and Part B.

29.2 The operation of the tertiary sampler cutter should be observed to determine that the cutter cuts the full coal stream and that it does so in the manner described in the Characteristics and Movement of Sampling Device section (9.5) of Part A.

29.3 Tertiary cutter velocity must be uniform across the entire coal stream and conform to the recommendations of the Increment Collection Method to be Used and Characteristics and Movement of Sampling Device sections (9.2.1 and 9.5) of Part A, and the Speed of Sampling Device and Speed of Sampling Device (After Crushing) sections (17.10.1.3 or 17.10.2.3) of Part B.

29.4 The cutter opening shall conform to the Dimensions of Sampling Device section (9.4) of Part A, and 17.10.1.2 or 17.10.2.2 of Part B, which include the recommendation that the opening shall not be less than 30.0 mm [1¼ in.].

29.5 Minimum increment mass before sample crushing shall conform to Table 1 of Part A. At present, there are no minimum increment masses after crushing given in Practice D2013/D2013M.

29.6 The tertiary or final cutter will be out of the coal stream in the *at rest* position.

29.7 The sampler shall be enclosed to minimize moisture change as specified in the Preservation of Moisture section of Part A. (Also see the Preservation of Moisture section (17.5) of Part B.)

29.8 When there is a crushing stage, the paragraph on the number of increments under Procedure B of Practice D2013/D2013M specifies for mechanical division of the sample that at least 60 increments be taken at each stage of division.

Therefore, this criteria can be used for determining the minimum number of increments to be collected by the tertiary or final sampler. Although not required by the standard, it is good practice to have at least one increment at every stage of reduction for every primary increment.

30. Cautions for Collecting Final Sample

30.1 The cautions for collecting the final sample discussed in Section 29 of this practice apply regardless of whether the primary increments are collected by cross-belt, falling-stream, or auger sampling devices. References are provided to applicable sections of Part A and Part B.

30.2 The container receiving the final sample increments shall be enclosed to minimize moisture change, as specified in the Preservation of Moisture section (9.7) of Part A. (Also see the Preservation of Moisture section (17.5) of Part B.)

30.3 The transfer pipe or chute from the final sampler to the final sample container should be as short as possible. There is a potential for significant moisture change if the relatively small amount of final sample falls through a long transfer pipe or chute.

31. General Considerations to be Observed by the Inspector

31.1 ASTM standards allow for flexibility in designing mechanical systems so that at any point in the division and reduction of the primary sample, such reduction and division can be done *online* in the mechanical sampling system or *offline* by a number of options and equipment specified in Practice D2013/D2013M. Practice D2013/D2013M also specifies in Table 1 the minimum sample mass for four top sizes.

31.2 The conveyor belts shall be started and run for a period of time before the coal to be sampled is placed on the belt so that foreign substances (including water) are purged.

31.3 The mechanical sampling system should be started at some time in advance of the start of conveying coal. Where hydraulic drives are used, sufficient time should be allowed for the hydraulic oil and the associated system to reach temperature equilibrium. After reaching temperature equilibrium, cutter velocities should not change during sampling.

31.4 It is recommended that the inspector review any records or logs maintained by the operator. These records or logs may include such things as amounts of coal handled, amounts of coal sampled, and notations as to system malfunctions, stoppages, pluggages, or other deficiencies. The inspector may also wish to use a checklist, such as the example in Appendix X1, when actually conducting an inspection. It is recommended that the inspector complete all items on the checklist pertinent to the inspection. Such a checklist is also recommended for inclusion in the operator's records.

31.4.1 Prior to the inspection of a mechanical sampling system, the inspector should review the most recent bias test or pre-bias test inspection report where the sampling system operation is described. A review provides a point-of-reference for the inspector to compare the current system performance to the last bias test where the system was operating properly.

31.4.2 The inspector should review the sampling system's Sample Ratio data. A review of this data can help identify if the system has been experiencing problems with out-of-control conditions, or problems in achieving the design Sample Ratio. Any ratio problem found should be identified in the inspection report; and the possible cause(s) and correction(s) should be noted.

31.4.3 Some sampling systems have operating programs which have Sample Ratio masses which vary due to multiple system performance settings. With these systems, if all sample collection is to be charted, separate control charting and ratio data for each system setting should be considered. The inspector should take this into account when assessing Sample Ratio data.

PART D – BIAS TESTING A MECHANICAL COAL SAMPLING SYSTEM [Old Practice D6518]

32. Scope

32.1 *Part D—Bias Testing of a Mechanical Coal Sampling System*—Presents sample collection and statistical evaluation procedures for testing mechanical sampling systems (including auger systems), subsystems, and individual system components for bias. It is the responsibility of the user of this practice to select the appropriate procedure for a specific sampling situation.

32.1.1 Part D does not purport to define an absolute bias. Bias defined by this practice is the difference between the population mean of the mechanical sampler test results and the accepted reference value.

32.1.2 The values stated in either SI units or inch-pound units are to be regarded separately as standard. The values stated in each system may not be exact equivalents; therefore, each system shall be used independently of the other. Combining values from the two systems may result in non-conformance with the standard.

33. Summary of Practices

33.1 This practice consists of procedures for comparing material collected by mechanical sampling systems (including auger systems) to reference or surrogate samples collected by alternate procedures from individual batches or lots of coal, numbered 1 through n , in chronological order, providing n sets of samples. After collection, the test samples are prepared and analyzed using applicable ASTM test methods. For each measured characteristic, a numerical difference in the measurements between the observed system value and the observed reference value is calculated for each set of samples. Using the statistical procedures described in this practice, the set of differences from the n sets is then examined for evidence of bias between the mechanical system and reference measurements.

33.2 This practice is based on matched-pair experimental designs. The practice describes two procedures of sample collection, paired increment and paired test batch, and two statistical procedures for assessing bias: nonparametric and parametric. The Wilcoxon signed rank test procedure is a nonparametric test, assuming only symmetry of each of the univariate differences, the Hotelling's T^2 test is a parametric test assuming multivariate normality of the differences, and the Student's t -test is a parametric univariate test assuming normality of the differences.

34. Significance and Use

34.1 It is intended that these procedures be used to provide an estimate of the bias of a mechanical sampling system used to collect samples of coal. Mechanical coal-sampling systems are used extensively in industry for collecting samples while coal is being conveyed or transported in various stages of production, shipment, receipt, and use. The bias of the sam-

pling system, in the measurement of coal quality, can have significant commercial and environmental consequences.

34.2 Bias as determined by these procedures need not be a constant or fixed value and can reflect the bias only under the conditions, which prevailed during the test period. Variables including, but not limited to, changes in the operation of the sampling system, the coal transfer operation, or the coal-sampling characteristics can cause changes in test results; therefore, if system bias is unacceptable, correct the cause rather than compensate for it.

34.3 A single bias test may not provide a meaningful generalized expectation of past or future system performance but an ongoing testing program can. Such a program may be established by mutual agreement of the interested parties.

34.4 Data used to draw conclusions regarding bias are subject to sources of error other than those attributable to the biases in the sampling system. Biases introduced by handling, preparation, and analysis of samples could also contribute to the appearance of a system bias. Therefore it is important to carefully follow ASTM standard methods for sampling, sample preparation, and testing, and to exercise careful quality control.

34.5 In all cases, the test plan should approximate normal system operation and not be a source of bias itself. This is especially critical when the sampling system batch processes several consecutive increments at any stage. In this case, the system samples should consist of all the coal from an entire batch.

34.6 Since this practice includes several different methods of sample collection and statistical procedures, the procedures used for both sample collection and statistical processing must be chosen before the test is conducted. This does not preclude subjecting historical test data to alternate statistical procedures for alternative purposes.

35. Hazards

35.1 *This standard does not purport to address all of the safety concerns, if any, associated with its use. It is the responsibility of the user of this standard to establish appropriate safety and health practices and determine the applicability of regulatory limitations prior to use.*

35.2 **Warning**—The operation, inspection, maintenance, and cleaning of mechanical sampling equipment involves hazardous operations, conditions, and equipment that may result in serious bodily harm or death. These hazards include, but are not limited to, intermittent operation, remote startup, powerful electrical or hydraulic drives, moving conveyors, crushers, etc.

35.3 It is essential that personnel wear all required personal protective equipment. Personnel should be fully knowledgeable of, and follow, all site-specific safety rules and governmental regulations regarding the equipment in question,

including, but not limited to, releasing stored energy, confined spaces, opening of inspection doors during operation, and electrical power lock out/tag out. Be certain to de-energize main power source and not rely on local or control circuits.

35.4 Stopped belt sampling involves special hazards not associated with normal mechanical sampling routine. These include, but are not limited to, working around moving conveyor belts, accessing the conveyor at the point of sample collection, and handling heavy stopped belt cutters and large sample masses. Special precautions need to be taken to ensure there is no chance of the conveyor moving before personnel are clear of any hazards.

36. Guidelines For When To Bias Test

36.1 Bias test a mechanical sampling system after installation.

36.2 *Retest:*

- (1) after a system has been relocated,
- (2) after the design, configuration or operation of major components have been modified (major components being cutters, dividers, chutes, crushers, feeders or final collection apparatus) which may affect moisture and or particle size selection,
- (3) after the conveyor from which the primary increment is collected is modified so as to change the speed (affecting both cross-belt and falling-stream cutters), troughing angle (affecting cross-belt cutters) or discharge angle (affecting falling-stream cutters), and
- (4) after a system has been repaired from structural damage or deterioration due to vibration, abrasion, corrosion, abuse or lack of maintenance such that moisture content and or particle size selection could have been impacted.
- (5) Provided that none of the above applies, appropriate quality management programs can be utilized to indicate the need for retesting. Such quality management programs may include system inspections (refer to [Appendix X1](#)), monitoring sampling ratios (refer to [Appendix X2](#)), continuous bias monitoring (refer to [Appendix X3](#)), or a combination of these.

36.3 Because some of these changes are not readily determined, it is good practice to retest the samplers periodically.

37. Apparatus

37.1 *Sample Collection Devices:*

37.1.1 *Stopped-Belt Divider*—A device similar to that illustrated in [Fig. A1.1](#). The width between the divider plates must be the same throughout the divider, and no less than three times the nominal top size of the coal. Assure the width is sufficient, and the design of the mechanism adequate, to enable quick and easy removal of all coal lying on the conveyor belt between the divider plates, including very fine material.

37.1.2 *Surrogate Reference Sample Collection Tools*—Devices used to subsample internal coal flows of a mechanical sampling system. These devices must be capable of extracting a full stream Type I-A-1 or I-B-1 increments (see Practice [D2234/D2234M](#)) from a mechanical sampling system stream of coal.

37.2 *Sample Preparation Equipment*—Prepare all bias test samples using equipment as specified in Practice [D2013/D2013M](#).

38. Description of Test Procedures

38.1 *Sample Collection:*

38.1.1 This practice offers three basic test designs for bias testing of mechanical sampling systems. They are referred to as the paired increment, the paired test batch, and the intraphase test designs. The basic distinguishing features of the designs are given in [38.1.2.1 – 38.1.4.3](#). (**Warning**—Collecting test samples on multistage sampling systems, or testing individual system components or combinations of components on multistage systems, by either paired increment or paired batch experimental designs can result in atypical moisture losses because of a disturbance or disruption of routine operating conditions. Disturbance or disruption of routine operating conditions is generally related to one or more of the following: the time interval involved in extraction of increments, interruption of internal flow within the sampling system, and induced ventilation within the sampling system. Every effort must be made to minimize adverse effects of such factors.)

38.1.2 *Paired Increment Design:*

38.1.2.1 Paired increment procedures involve the collection of system increments and reference samples, which are paired for comparison purposes. Collect reference samples from the same area of the conveyor or as near as possible to the location where the corresponding sampling system's primary increment(s) is extracted so a close physical association is created. Some variations of the test design can be collecting one reference sample for each sampling system primary increment and bracketing the location from where the system's primary increment is withdrawn with two reference samples or if the system's primary increments are normally batched through the remainder of the sampling system. Another option may be collecting multiple system primary increments within the bracket of reference samples.

38.1.2.2 The paired increment experimental design requires intermittent operation of the coal handling and sampling systems because of the need to stop the conveyor to remove reference samples.

38.1.2.3 Operating the sampling system under the control of system logic is the preferred practice. This procedure involves operating under system logic until it initiates collection of a primary increment, then manually tripping the conveyor system by pushing the stop button to shut it down. This technique requires that only the main conveyor shut down, while the sampling system purges under the routine operating settings of system logic, and may or may not, shut down. System logic timers should continue to operate without interruption.

38.1.2.4 Collect reference increments using a systematic collection scheme.

38.1.2.5 The paired increment design can be used to test individual system components.

38.1.3 *Paired Test Batch Design:*

38.1.3.1 In the paired-sample test batch design, the system sample and reference sample(s) are collected during some predefined period of time or tonnage throughput. The volume

of coal processed during the timed or tonnage interval is referred to as a test batch. The system sample is that sample collected from the test batch by the sampling system operating in its normal mode. The reference sample consists of one or more stopped-belt increments taken from the same test batch.

38.1.3.2 The reference sample and mechanical system sample originate from the same test batch of coal.

38.1.3.3 Operate the sampling system at the operating settings preselected for the test, the same for every batch.

38.1.3.4 Use a random sampling scheme developed according to the requirements of Practice E105. A random start followed by systematic selection of increments thereafter is acceptable practice.

38.1.3.5 The paired test batch design often is used to test the overall mechanical system.

38.1.4 *Intraphase Test Design:*

38.1.4.1 This testing pertains to obtaining the overall sampling system bias estimate by combining data from two or more separate test phases, one phase of which includes a reference sample. Each test phase obtains data on one or more components or subsystems. The data from the separate test phases are statistically combined for an estimate of the overall system bias. This approach is useful when interruptions to the sampling system would impose an experimentally induced moisture loss. The sampling system uses batch processing instead of linear processing. This approach is also useful when it is necessary to diagnose the cause of a bias discovered by one of the other test procedures.

NOTE 10—In the first phase of a typical two-phase test, the primary sampler is tested for bias using a paired increment test that compares samples collected from or at the discharge of the primary sample conveyor (surrogate samples) with stopped-belt reference samples. If the primary sampler is found to be acceptable, then in the second phase a paired-sample batch test compares surrogate samples, collected in the same manner as the first phase, to system samples to test the remainder of the sampling system.

38.1.4.2 Phased testing takes advantage of the fact that mechanical coal sampling and on-line preparation is a linear process and the overall results of this linear process can be determined by separately investigating the individual parts. The data obtained from individual process parts is combined statistically to obtain an estimate of the overall systems performance.

38.1.4.3 The test data, from the separate phases, are combined by algebraically adding the mean differences and by obtaining an estimate of the overall standard deviation by summing the variances associated with each phase and taking the square root.

38.2 *Statistical Procedures*—The matched pairs experimental design of the test for bias reflects the underlying requirements for meaningful assessment of bias test data. This practice supports both parametric and nonparametric procedures, either of which can encompass univariate or multivariate statistical analysis for assessment and interpretation of results, both of which assume independence of individual differences. The distinction between parametric and nonparametric statistical analysis lies in the assumptions regarding the distribution of the population of differences. Parametric statistical analysis is predicated on a normal distribution.

38.2.1 *Wilcoxon Signed Rank Nonparametric Test, Nonparametric Analysis*—This test is based on creating a superset of the population of differences by differencing every possible combination of the observed differences and sorting them in ascending order. The median of this distribution is taken as the point estimate of bias. Two-sided confidence limits for univariate and multivariate analysis for up to five variables are established based on the Bonferroni inequality, using Table A2.12. Interpretation of the results depends on whether or not the confidence interval encompasses zero for the univariate case, and on whether or not the confidence interval of any one of the variables encompasses zero in the multivariate case.

38.2.2 *Student's t and Hotelling's T^2 Parametric Analysis*—The parametric method requires computation of the mean and the standard deviation of the differences of the variable in question for the univariate case or of each of the variables for the multivariate case. The mean(s) are taken as the point estimate(s) of bias. The confidence interval for the univariate case and the confidence regions for the multivariate case are established using the corresponding standard deviation and Hotelling's T^2 values. Interpretation of the results depends on whether or not the confidence interval falls within the predetermined tolerable bias region.

38.2.3 *Variance Addition for Intraphase Test*—Intraphase statistical analysis is conducted using Student's t -test for the paired difference between two means. Mean differences for each test phase are added to arrive at an overall mean difference for the system. The estimated standard deviation of the combined phases is obtained by addition of the corresponding variances of the phase tests and taking the square root. Interpretation of the results depends on whether or not the confidence interval encompasses zero.

39. Organization and Planning

39.1 *Data Required to Plan Test:*

39.1.1 Obtain information pertinent to operation of the mechanical sampling system so that detailed test procedures can be prepared.

39.1.2 Obtain the layout of the associated coal handling system including description of coal conveyor widths, belt speeds, troughing idler angles, coal flow rates, availability, and permissible conveyor stops and restarts.

39.1.3 Determine the condition of and operation of the sampling system before doing a bias test. It is recommended that the inspection be done in accordance with Part C, by personnel familiar with the operation of the mechanical sampling system and knowledgeable in ASTM standards.

39.1.4 Obtain complete sampling system operating information, including sample cutter widths (in the case of auger systems the diameter of the auger assembly and distance between flights), sample cutter operating intervals and velocities, sample extraction rates for each stage of sampling, sample crusher product top sizes, accessibility for sample collection, and typical lot sizes. Identify adjustments typically made to accommodate different lot sizes or other operating conditions. Sources of information can include design parameters, or physical measurements, or both.

39.1.5 Obtain a description of coals typically sampled. Include the nominal coal top size, typical quality

characteristics, and a description of the type of preparation, such as washed, crushed run-of-mine, or blended coal.

39.1.6 Calculate the design sampling ratio for the system and examine the system sampling ratios for indications of an out-of-control condition, unintended change in the operational components within the system that affect the system sample mass, or both. Refer to [Appendix X2](#) for more information on evaluating system sampling ratios.

39.2 *Select Test Conditions*—Make the following decisions and selections before the test:

39.2.1 *Selection of Test Coal*—If coals of different quality are available for use in the bias test, a selection of the specific coal(s) to be used must be made before collection of test samples. Efforts should be made to keep the coal quality as consistent as is practical during the test. The user of this practice is cautioned that a change in coal quality could invalidate the statistical results and that bias can change with coal quality.

39.2.2 *Selection of Analytical Test Parameters for the Test:*

39.2.2.1 The specific coal quality characteristics to be used in the bias test should be selected before the test.

39.2.2.2 Make the same analytical determinations on both the reference and system samples. Use the observed values for each of these coal characteristics to make inferences concerning system bias of the sampling system against the chosen reference. A bias test using this practice can be based on one or more characteristics measured for the test comparison. As many as five coal characteristics can be used when testing for bias using the statistical practices in [38.2.1](#).

39.2.2.3 The greater the number of coal characteristics used in the statistical inference for a fixed number of paired data sets the larger the confidence interval widths will be; thus, the user should give consideration to limiting the number of coal characteristics to those which would yield a reasonable evaluation of the sampling system. Arguments can be made that only determinations of moisture and dry ash are necessary for evaluating bias of a sampling system, and that it is unlikely bias of other coal characteristics would exist independent of bias of either moisture or dry ash.

39.2.3 *Selection of Sampler Operating Mode*—Sampler operation and coal transfer rate should not change during the course of the test. If the sampler has the ability to operate in different modes (different lot sizes, tonnage rates, time or mass basis, and so forth), the user must select the mode or modes of operation in which the sampler is to be tested.

39.2.4 *Selection of Collection Method*—Under Section [38](#), the user will need to select an increment collection method. The methods listed and described in [38.1.2](#) and [38.1.3](#) are collection of paired data on an increment basis and collection of paired data on a test-batch basis.

39.2.5 *Selection of Method to Collect Reference Samples*—Practice [D2234/D2234M](#) lists several different methods for increment collection. Condition “A” (Stopped-Belt Cut), in which a full cross-section of coal is removed from the stopped main conveyor belt, is considered the reference method and is the highest order of sampling methods available. For the purpose of this practice, surrogate samples can be obtained from increments collected by methods other than stopping the

main coal flow belt. Such surrogate samples, collected in accordance with Practice [D2234/D2234M](#), Conditions “A” or “B” and when proven free of significant bias relative to reference samples may be considered acceptable for evaluation of a mechanical sampling system’s components, excluding the primary cutter.

39.2.5.1 In the case of testing an auger sampler a stopped-belt sample can be removed from a conveyor that loads or removes a test batch from a truck, railcar, barge or stockpile.

39.2.6 *Selection of Statistical Procedures*—Select a statistical procedure by which to evaluate the data from the bias test. The statistical procedures listed and described in [Annex A2](#) of this practice are as follows: Wilcoxon Signed Rank Nonparametric Procedures, Hotelling’s T^2 Parametric Procedures, and Combined Variance Procedures for Intraphase Testing.

NOTE 11—Hotelling’s T Squared procedure can only be used when the (multivariate) difference data are normally distributed and when they are statistically independent (see [Annex A2.3](#)). Therefore, it is not possible to choose Hotelling’s T Squared procedure to test for significance of bias until the data have been collected and the differences have been tested for normality and statistical independence. The nonparametric Wilcoxon procedure described in [Annex A2.1](#) can be used irrespective of the distribution of the differences. The Wilcoxon procedure as described does include a test for independence.

39.2.6.1 When the system is tested for bias using only one coal characteristic it is acceptable to use the Student’s t univariate test (which is equivalent to the Hotelling’s T Squared in this case). For troubleshooting purposes only, it is also appropriate to apply this procedure to each coal characteristic when trying to locate the cause of bias determined by a multivariate test such as the Hotelling’s T Squared Procedure.

39.2.6.2 When more than one coal characteristic is used to test the sampling system for bias, a statistical procedure such as a Wilcoxon or Hotelling’s T Squared procedure must be used. It is inappropriate to apply a univariate test to several characteristics simultaneously, other than for troubleshooting, because the width of the confidence intervals would be understated for the 95 % confidence interval.

39.2.7 *Selection of Number of Paired Data Sets*—In the absence of information on the variance of differences of the paired data sets, it is not possible to estimate, before the test, how many data sets are needed to detect a bias at the largest tolerable bias (LTB) chosen for the test. Recognizing this lack of information, it has been a common practice in the industry to initially collect between 20 and 40 sets of data, with the actual number being determined by perception of the variability of the coal and the use to be made of the test results. At any time during the test, analysis of current data collected can enable the user to determine if additional data sets are needed to reach specified test precision. Alternatively, if information is available on the sampling variance, or on the variance of differences of similarly collected paired samples from the test coal or similar coals, the information can be used to optimize test design. Using such information, Practice [E122](#) can be helpful in planning the number of paired data sets.

39.2.8 *Selection of Test Batch Size*—Select the batch size of coal that will be used for the data sets. For the paired increment test design, this can be the region of coal on the conveyor from which the reference and system sample increments are to be

collected. For a paired test-batch design, this can be based on time or tonnage. In the case of testing an auger sampler, this can be a load from or for a truck, railcar, barge or stockpile. In either test design, the batch size should be approximately the same throughout the entire test period. Test batch size should take into consideration the mass of retained system sample and the necessity to ensure that small retained samples are not adversely affected by the sample collection process (change in moisture, etc.). See [Annex A1 – Annex A3](#) for additional information regarding the selection of test-batch size.

39.2.9 Selection of Number of Reference Increments/Samples per Test Batch of Coal—Select the number of reference increments/samples per test batch. For a paired increment test design this can be one or more increments such that the reference sample is collected nearby or brackets the region of coal from which the system’s increment(s) are to be obtained. For a paired test-batch design, one or more reference increments can be collected during the chosen batch interval. In general, the fewer the number of increments per test batch, the higher the variance of paired sample differences and the lower the power of the test for a given number of paired sets. For coal relatively uniform within individual test batches, only one or two reference increments might be adequate. For a coal with characteristics highly variable within individual test batches, it may be necessary to take more reference increments from each test batch.

39.2.10 Selection of Reference Sample Collection Times and Preparing a Collection Schedule:

39.2.10.1 Prepare a schedule for collection of reference increments from test batches before beginning the collection of bias test samples.

(1) In the case of an auger system, operate the system until the entire primary increment is processed through the sampler.

39.2.10.2 The reference increments should be collected from the test batch interval such that all coal within that test batch interval has an opportunity to be collected over the course of the test. Selection of timing for collection of the reference samples must be by a random method.

39.2.10.3 Operate the mechanical sampling system continuously during the processing of each test batch. If the test batch size is smaller than a lot, consider operating the system continuously while processing several consecutive test batches.

39.2.10.4 The test batch interval should include only the cumulative time during which coal is flowing.

39.2.10.5 Precautions should be taken, in the choice of increment collection times, that test sample collection minimally affects the coal flow through the sampling system.

39.2.10.6 Samples collected for a bias test should be collected in accordance with Practice [D2234/D2234M](#) (Conditions “A” or “B”).

39.3 General Sample Handling—As rapidly as possible, seal all test samples in moisture proof containers. Identify, weigh, and store the containers in a protected area before beginning the next test batch interval. Some coals are more susceptible to oxidation, which may require additional precautions such as vapor and gas impervious storage containers.

NOTE 12—Any unaccounted for moisture change in the test samples, that results from collection and handling, will show up as either an under

or over estimate of any moisture difference attributed to the sampling system.

39.3.1 Preparation of Test Samples:

39.3.1.1 Minimum final masses (after preparation), which conform to the limits specified in Practice [D2013/D2013M](#) are recommended. It is recognized that this will not be possible in all cases with the system sample. Samples with masses less than those specified in Practice [D2013/D2013M](#) shall only be used by mutual agreement of the interested parties. It must be recognized that the use of system sample masses, which substantially are less than those recommended can decrease the ability of the test to detect a bias or cause false detection of bias. Small sample masses could be detrimental especially to the determination of moisture bias if the samples are not handled with special care to preserve moisture.

39.3.1.2 Reweigh all reference increments and all system samples before combining, crushing, or dividing. List each mass in the bias test report.

39.3.1.3 Multiple reference samples, collected during a single test batch, can be physically composited, prepared, and analyzed or individually prepared and analyzed, and the weighted average analysis result of the individual samples used as the reference value.

39.3.1.4 Total moisture shall be determined by [D3302](#) Referee or Commercial method. The Referee method should be used on stopped-belt reference samples when moisture loss during preparation is suspected. Coals with visible surface moisture, coals where fines adhere to a metal bar after inserting into the coal sample, coals that are difficult to process through a riffle after being crushed, and coals that plug the crusher to be used in preparing test samples are good indicators for selecting the Referee method, i.e. floor drying the stopped-belt sample and then conducting a two-stage moisture test on the floor dried sample. Some of above observations may result in the loss of one or several paired test sets if the moisture method cannot be properly determined prior to the bias test. Use the same moisture method on all the bias test reference samples.

39.3.1.5 Measure and include in the total moisture result the moisture condensation adhering to the interior of the sample containers used for transporting and storing samples.

39.3.2 Laboratory Analysis of the Test Samples:

39.3.2.1 Use consistent procedures for laboratory analysis throughout the test for bias.

39.3.2.2 Every effort should be made to analyze the test samples quickly to avoid deterioration of the test samples as a result of lengthy storage time.

39.3.2.3 All test samples from a test batch shall be concurrently processed and analyzed. The purpose is to minimize introducing systematic error resulting from differences in treatment during preparation and analysis.

39.3.2.4 Laboratory record keeping and quality control practices shall be in accordance with Guide [D4621](#). Record and report the results of all analytical determinations on each test sample.

39.4 Information to be Obtained and Reported:

39.4.1 A log of test sample collection activities during sample collection should be kept. Include the following information:

39.4.1.1 Weather conditions, including temperature and state of precipitation.

39.4.1.2 Date, starting and ending time of the collection of each test sample.

39.4.1.3 The mass and number of increments comprising each test sample shall be recorded. It is recommended that all test samples be weighed before and after preparation to monitor preparation losses.

39.4.1.4 Identification of responsible personnel involved in the test sample collection process.

39.4.1.5 A general description of the origin and identification of the coal used during the test for bias.

39.4.1.6 Date, time, and description of failures of mechanical sampling equipment or coal-handling equipment, and duration of downtime.

39.4.1.7 Description of the sampling system and its operation during the test.

39.4.1.8 Description of test design, sample collection, sample handling, and statistical methods used for the test.

39.4.1.9 Analytical test results on each sample.

39.4.1.10 Results of all statistical analysis.

40. Keywords

40.1 auger sampling; barge sampling; coal; coal sampling; inspection; mechanical sampling; railroad car sampling; sample division; sample reduction; sampling systems; split-spoon sampling; statistical analysis; stock pile sampling; truck sampling

ANNEXES

(Mandatory Information)

A1. COLLECTION OF REFERENCE SAMPLES (SECTION D – BIAS TESTING)

A1.1 Reference Samples

A1.1.1 General Information on Collection of Reference Samples:

A1.1.1.1 A stopped-belt sample provides the best possible reference sample and is the accepted method for bias test reference sample collection.

A1.1.1.2 It is important to collect the reference sample by minimizing delimitation, handling and preparation errors. Any of these types of errors will affect the results of the test on the sampling system.

A1.1.1.3 When moisture is being tested as one of the characteristics, it is important that reference samples be collected rapidly and that conveyors are shut down for as short a time interval as possible to minimize drying to both reference and system samples. It is also important that all samples be placed in moisture tight containers (typically plastic buckets with lids or plastic bags) that can be sealed until further processing can take place.

A1.1.1.4 If any of the coal used for the bias test is exposed to the environment where reference samples and system samples are collected and anywhere in between, do not collect samples during precipitation or strong winds which could cause moisture contamination or sample loss.

A1.1.1.5 One or several reference (stopped-belt) samples can be collected per test set (see [Table A1.1](#)). If multiple reference samples are collected during a single test set or batch, the reference samples in that set or batch can be physically composited, prepared, and analyzed or individually prepared and analyzed, and the weighted average analysis result of the individual samples used as the reference value.

A1.1.1.6 When two or more reference samples are collected per belt stoppage, they should be collected simultaneously to minimize moisture differences between the two samples.

TABLE A1.1 Schedule for Collection of Stopped-Belt Increments

Test batch interval = 60 min
 Reference increments per test batch = 3
 $K = 60/3 = 20$ min
 Random No. = Any whole number from 1 to K
 $T_1 =$ Random Number
 $T_2 =$ Random Number + K
 $T_3 =$ Random Number + $2K$

Test Batch	Random No.	T_1	T_2	T_3
1	16	16	36	56
2	7	7	27	47
3	2	2	22	42
4	13	13	33	53
5	6	6	26	46
–	–	–	–	–
–	–	–	–	–

A1.1.1.7 The spacing of reference samples pertains to the kind of interval between samples. Two spacing methods are recognized: systematic and random.

(1) Systematic Spacing is typically used in the Paired Increment Design ([38.1.2](#)) where the reference samples are collected from the same area of the conveyor or as near as possible to the location where the sampling system's primary increment is extracted so as to create a close physical association. Some variations of the test design can be: collecting one reference sample for each sampling system primary increment; bracketing the location from where the system's primary increment is extracted with two reference samples or if the system's primary increments are normally batched through the remainder of the sampling system, collecting multiple system primary increments within the bracket of two reference samples.

(2) Random Spacing is typically used in the Paired Test Batch Design ([38.1.3](#)) where the reference samples are spaced by random time or tonnage intervals over the test batch.

A1.1.2 Procedure for Collection of Stopped-Belt Reference Samples:

A1.1.2.1 Stop the conveyor for removal of the stopped-belt reference sample at the prescribed interval or location determined in the planning stage for the bias test and make the work area safe.

A1.1.2.2 Using a divider similar to [Fig. A1.1](#) below, center it perpendicular to the coal flow over the location where the reference sample is to be extracted. Human discretion should not influence the location on the conveyor where the divider will be placed for removal of the stopped-belt sample. The divider will separate the full cross section sample from the other material on the conveyor, reducing delimitation error, and facilitate the removal of the sample while reducing handling errors.

A1.1.2.3 Lower the stopped belt divider on top of the material. Be careful not to disturb the material in the area from where the reference sample is to be removed. Push down on the divider until it completely slices through the material and reaches the conveyor belt. A rocking motion or tapping with a hammer can be used to move the divider through the material particularly on large conveyors with coarse coal.

A1.1.2.4 Once the divider is in place, start removing the material between the divider with a shovel or other appropriate tool and place it in a container without spilling any of the particles. Complete the removal of fine particles with a brush or wiper. If moisture is a parameter to be measured, remove the sample as quickly as possible. Seal the container(s) as soon as the entire sample has been collected.

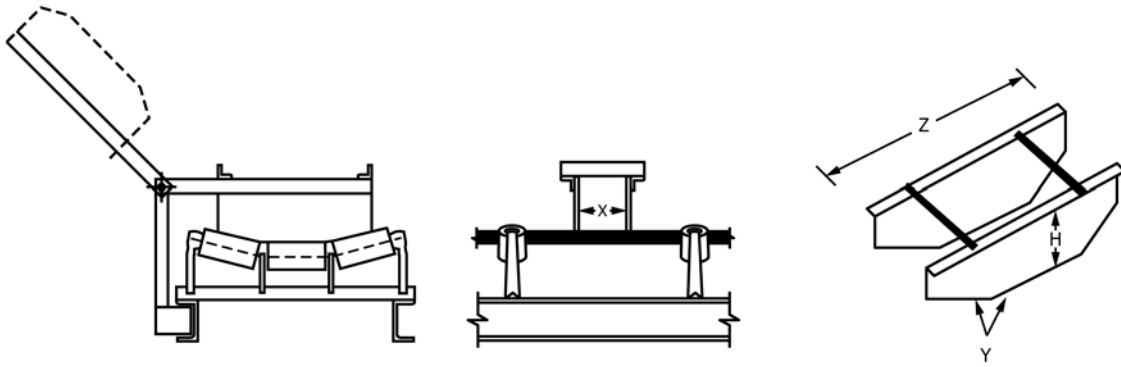

The “x” dimension shall be no less than three times the nominal top size of the coal but of sufficient width to enable quick and easy removal of all coal lying on the conveyor belt between the divider plates, including very fine coal.

FIG. A1.1 Bias Test Stopped-Belt Divider

A1.1.2.5 Once all the material within the divider has been collected, remove the divider from the conveyor and continue on with the testing program.

A1.1.3 Design of the Stopped-Belt Divider:

A1.1.3.1 A device similar to that illustrated in [Fig. A1.1](#) below can be used to delimit the material within the divider from the other material on the conveyor.

A1.1.3.2 The side plates of the divider must be parallel so the distance “X” between them is the same throughout. The width dimension “X” must be at least three times the nominal top size of the material and sufficient to enable quick and easy removal of all material lying on the conveyor between the plates, including very fine particles. The thickness of the plates must be sufficient that they remain parallel when the divider is inserted into the material on the conveyor.

A1.1.3.3 The bottom edges “Y” of the divider plates should be placed as close as possible to the loaded contour of the conveyor belt to prevent leakage of material while removing the sample, as close as 1/8 in. is recommended. The contour of the conveyor belt should be measured from a loaded belt for designing the contour of the divider’s bottom edges.

A1.1.3.4 The length “Z” of the divider should exceed the width of the material on a fully loaded conveyor by at least 2 (two) inches on each end to minimize delimitation errors.

A1.1.3.5 The height “H” of the divider should exceed the maximum expected coal depth on the conveyor by at least 2 (two) inches to minimize delimitation errors.

A1.1.3.6 The divider should be designed sturdy enough to withstand at least one-and-a-half times the planned number of insertions into the material on the conveyor without changing dimensions. This is particularly important if the divider must be forced through the material by tapping or rocking it.

A1.2 Surrogate Samples

A1.2.1 A surrogate sample is composed of one or more increments collected from a coal stream within the mechanical sampling system. In bias testing, the surrogate samples normally are extracted from a coal stream at the discharge of a feeder. Surrogate samples can be collected from primary increment streams, as well as from other system sample streams.

A1.2.2 The mass of each surrogate increment should be in accordance with Practice [D2234/D2234M](#), Conditions “A” or “B.” Each surrogate increment should consist of a complete cross section of the flowing coal stream. Care must be taken to minimize the effects of surrogate sampling on components downstream of the sampling point. See Practice [D2234/D2234M](#) for guidance on the number and mass of increments, which are needed for secondary increment collection.

**A2. STATISTICAL PROCEDURES
(SECTION D – BIAS TESTING)**

A2.1 Nonparametric Statistical Procedure

A2.1.1 As many as five coal characteristics can be used when testing for bias by this procedure.

A2.1.2 *Step 1*—As illustrated by the example in **Tables A2.1-A2.3**, tabulate the reference observations and system observations for all coal characteristics. Then, compute and tabulate the individual differences between reference and system values for each test batch as shown in the columns of the tables. In computing differences, subtract each reference value from each corresponding system value, retaining the sign of the result. Compute the sample average of the reference values, the sample average of the system values, and the sample average of the differences for each coal characteristic.

A2.1.3 *Step 2*—For each coal characteristic, arrange the n differences in ascending order, as illustrated in **Table A2.4**. Determine the sample median value. When there are an odd number of differences, the median is the $(n + 1)/2^{\text{th}}$ ordered difference. When there are an even number of differences, the median is the average of the $n/2^{\text{th}}$ difference and the $(n + 2)/2^{\text{th}}$ difference. For the example illustrated in **Table A2.4**, the sample median for each characteristic is the average of the 8th and 9th differences.

A2.1.4 *Step 3*—Prepare a graph of the differences by consecutive test batch number, beginning with the first batch, and ending with the n^{th} batch. Plot the sample median of the differences as a straight line across the graph.

A2.1.5 *Step 4 Test for Independent Differences*—To draw inference about system bias correctly using the procedures of this practice, the sample differences must be independent. When the hypothesis of independence is rejectable, the process used to draw inference about bias can be suspect or viewed as inconclusive.

TABLE A2.1 Observed Moisture Values

	SB Ref	Mech System	Sys-Ref	Above(+) Below(-) Median	Run No.
1	5.66	5.66	0.00	+	1
2	9.22	9.29	0.07	+	1
3	8.52	8.52	0.00	+	1
4	9.00	8.75	-0.25	-	2
5	8.47	8.38	-0.09	-	2
6	8.46	8.62	0.16	+	3
7	9.26	9.28	0.02	+	3
8	9.24	9.49	0.25	+	3
9	8.58	8.44	-0.14	-	4
10	5.85	5.80	-0.05	-	5
11	6.15	5.77	-0.38	-	6
12	9.03	9.01	-0.02	-	7
13	9.68	9.40	-0.28	-	8
14	11.25	10.08	-1.17	-	8
15	9.41	9.20	-0.21	-	8
16	5.75	5.66	-0.09	-	8
Sample Average	8.346	8.209	-0.136		

TABLE A2.2 Observed Dry Ash Values

	SB Ref	Mech System	Sys-Ref	Above(+) Below(-) Median	Run No.
1	8.92	8.89	-0.03	-	1
2	8.22	8.28	0.06	+	2
3	8.90	9.09	0.19	+	2
4	9.16	9.05	-0.11	-	3
5	9.00	9.08	0.08	+	4
6	9.03	9.03	0.00	-	5
7	8.20	8.21	0.01	-	5
8	8.10	8.26	0.16	+	6
9	8.74	8.89	0.15	+	6
10	8.53	8.58	0.05	-	7
11	8.80	8.73	-0.07	-	7
12	9.04	9.00	-0.04	-	7
13	8.16	8.38	0.22	+	8
14	8.49	8.47	-0.02	-	9
15	8.11	8.23	0.12	+	10
16	8.67	8.75	0.08	+	10
Sample Average	8.629	8.683	0.053		

TABLE A2.3 Observed Dry Sulfur Values

	SB Ref	Mech System	Sys-Ref	Above(+) Below(-) Median	Run No.
1	2.788	2.790	0.002		
2	2.858	2.895	0.037	+	1
3	2.703	2.705	0.002		
4	2.690	2.685	-0.005	-	2
5	2.688	2.740	0.052	+	3
6	2.698	2.700	0.002		
7	2.805	2.805	0.000	-	4
8	2.843	2.855	0.012	+	5
9	2.673	2.655	-0.018	-	6
10	2.705	2.700	-0.005	-	6
11	2.745	2.740	-0.005	-	6
12	2.630	2.605	-0.025	-	6
13	2.850	2.875	0.025	+	7
14	2.890	2.905	0.015	+	7
15	2.758	2.775	0.017	+	7
16	2.788	2.790	0.002		
Sample Average	2.757	2.764	0.007		

A2.1.5.1 Determine the number of runs (r) for each characteristic by first subtracting the sample median value found in Step 2 from each difference. If the result is positive, record a plus sign, and if negative record a minus sign, as illustrated by the columns of **Tables A2.1-A2.3**. Ignore differences equal to the median. Runs are sequences of values all above the median, as indicated by a series of positive signs, or all below the median, as indicated by a series of negative signs. After the number of runs has been determined, count the number of positive signs and the number of negative signs.

A2.1.5.2 When there are not an equal number of positive and negative signs, let n_1 denote the smallest number of like signs (all positive or all negative), and let n_2 denote the largest number of like signs. Observe that often the number of positive and negative signs will be equal, in which case set both n_1 and n_2 equal to the common number of like signs.

TABLE A2.4 Ordered Sample Differences

	Moisture	Dry Ash	Dry Sulfur
1	-1.17	-0.11	-0.025
2	-0.38	-0.07	-0.018
3	-0.28	-0.04	-0.005
4	-0.25	-0.03	-0.005
5	-0.21	-0.02	-0.005
6	-0.14	0.00	0.000
7	-0.09	0.01	0.002
8	-0.09	0.05	0.002
9	-0.05	0.06	0.002
10	-0.02	0.08	0.002
11	0.00	0.08	0.012
12	0.00	0.12	0.015
13	0.02	0.15	0.017
14	0.07	0.16	0.025
15	0.16	0.19	0.037
16	0.25	0.22	0.052
Median	-0.070	0.055	0.002

TABLE A2.5 Significance Values for Number of Runs

		$p = 1$			
n_1, n_2	l, u	n_1, n_2	l, u	n_1, n_2	l, u
3,5	3,-	9,10	7,14	13,18	12,20
3,6	3,-	9,11	7,14	13,19	12,21
3,7	3,-	9,12	8,15	14,14	11,19
4,4	3,7	9,13	8,15	14,15	11,20
4,5	3,8	9,14	8,16	14,16	12,20
4,6	4,8	10,10	7,15	14,17	12,21
4,7	4,8	10,11	8,15	14,18	12,21
4,8	4,-	10,12	8,16	14,19	13,22
5,5	4,8	10,13	9,16	14,20	13,22
5,6	4,9	10,14	9,16	15,15	12,20
5,7	4,9	10,15	9,17	15,16	12,21
5,8	4,10	11,11	8,16	15,17	12,21
5,9	5,10	11,12	9,16	15,18	13,22
6,6	4,10	11,13	9,17	15,19	13,22
6,7	5,10	11,14	9,17	15,20	13,23
6,8	5,11	11,15	10,18	16,16	12,22
6,9	5,11	11,16	10,18	16,17	13,22
6,10	6,11	11,17	10,18	16,18	13,23
7,7	5,11	12,12	9,17	16,19	14,23
7,8	5,12	12,13	10,17	16,20	14,24
7,9	6,12	12,14	10,18	17,17	13,23
7,10	6,12	12,15	10,18	17,18	14,23
7,11	6,13	12,16	11,19	17,19	14,24
7,12	7,13	12,17	11,19	17,20	14,24
8,8	6,12	12,18	11,20	18,18	14,24
8,9	6,13	13,13	10,18	18,19	15,24
8,10	7,13	13,14	10,19	18,20	15,25
8,11	7,14	13,15	11,19	19,19	15,25
8,12	7,14	13,16	11,20	19,20	15,26
9,9	7,13	13,17	11,20	20,20	16,26

Legend:
 p = number of coal characteristics tested,
 n_1 = number of fewest like signs,
 n_2 = number of most like signs,
 l = lower significance value, and
 u = upper significance value.

A2.1.5.3 Let p denote the number of coal characteristics used in the bias test. For each coal characteristic, obtain the lower and upper significance values l and u from **Tables A2.5-A2.9** using the appropriate values of n_1 and n_2 . If, for any tested coal characteristic:

$$r < l \text{ or } r > u$$

the data fails the test for independent differences and one concludes there is evidence the individual differences are not

TABLE A2.6 Significance Values for Number of Runs

		$p = 2$			
n_1, n_2	l, u	n_1, n_2	l, u	n_1, n_2	l, u
3,5	2,-	9,10	6,15	13,18	11,21
3,6	3,-	9,11	7,15	13,19	11,22
3,7	3,-	9,12	7,15	14,14	10,20
4,4	3,-	9,13	7,16	14,15	10,21
4,5	3,-	9,14	8,16	14,16	11,21
4,6	3,8	10,10	7,15	14,17	11,22
4,7	3,8	10,11	7,15	14,18	11,22
4,8	4,-	10,12	8,16	14,19	12,22
5,5	3,9	10,13	8,17	14,20	12,23
5,6	4,9	10,14	8,17	15,15	11,21
5,7	4,9	10,15	8,17	15,16	11,22
5,8	4,10	11,11	8,16	15,17	12,22
5,9	4,11	11,12	8,17	15,18	12,23
6,6	4,10	11,13	8,18	15,19	12,23
6,7	4,11	11,14	9,18	15,20	13,24
6,8	4,11	11,15	9,18	16,16	12,22
6,9	5,12	11,16	9,19	16,17	12,23
6,10	5,12	11,17	10,19	16,18	12,24
7,7	4,12	12,12	8,18	16,19	13,24
7,8	5,12	12,13	9,18	16,20	13,24
7,9	5,13	12,14	9,19	17,17	12,24
7,10	6,13	12,15	9,19	17,18	13,24
7,11	6,13	12,16	10,20	17,19	13,25
7,12	6,13	12,17	10,20	17,20	14,25
8,8	5,13	12,18	10,20	18,18	13,25
8,9	6,13	13,13	9,19	18,19	14,25
8,10	6,14	13,14	10,19	18,20	14,26
8,11	6,14	13,15	10,19	19,19	14,26
8,12	7,15	13,16	10,20	19,20	14,26
9,9	6,14	13,17	11,21	20,20	15,27

Legend:

p = number of coal characteristics tested,
 n_1 = number of fewest like signs,
 n_2 = number of most like signs,
 l = lower significance value, and
 u = upper significance value.

independently distributed. In all such cases in which the data fails the test for independent differences, include the following statement in the bias test report:

There is evidence the series of differences between reference and system measurements are not independent; therefore, it is possible the conclusions reached below about system bias are not correctly drawn because the assumptions made for the statistical test procedure are not fulfilled.

A2.1.5.4 When it is believed the reason is known why the measurements are not independent, state what is known in the bias test report. If the cause of lack of independence is unknown, include the following statement in the bias test report:

It might prove useful to undertake investigations to determine a cause (or causes) for the apparent lack of independence of the differences.

A2.1.5.5 For the illustrative data of **Tables A2.1-A2.4**, using **Tables A2.5-A2.9**, use of the procedure gives:

	r	n_1	n_2	l	u
Moisture	8	8	8	5	13
Dry ash	10	8	8	5	13
Dry sulfur	7	6	6	4	10

For each of the coal characteristics given in the illustration, the number of runs falls between the lower and upper points of significance; thus, there is insufficient evidence to conclude the observations within each series are not independent.

TABLE A2.7 Significance Values for Number of Runs

n_1, n_2	l, u	$p = 3$			
		n_1, n_2	l, u	n_1, n_2	l, u
3,5	–,–	9,10	6,15	13,18	10,22
3,6	–,–	9,11	6,15	13,19	11,22
3,7	3,–	9,12	7,16	14,14	10,20
4,4	–,–	9,13	7,16	14,15	10,21
4,5	3,8	9,14	7,17	14,16	10,22
4,6	3,–	10,10	6,16	14,17	11,22
4,7	3,–	10,11	7,16	14,18	11,22
4,8	3,–	10,12	7,17	14,19	11,23
5,5	3,9	10,13	7,17	14,20	12,23
5,6	3,10	10,14	8,17	15,15	10,22
5,7	4,10	10,15	8,18	15,16	11,22
5,8	4,10	11,11	7,17	15,17	11,23
5,9	4,–	11,12	8,17	15,18	11,23
6,6	4,10	11,13	8,18	15,19	12,24
6,7	4,11	11,14	8,18	15,20	12,24
6,8	4,11	11,15	9,19	16,16	11,23
6,9	4,12	11,16	9,19	16,17	12,23
6,10	5,12	11,17	9,19	16,18	12,24
7,7	4,12	12,12	8,18	16,19	12,24
7,8	5,12	12,13	8,19	16,20	13,25
7,9	5,13	12,14	9,19	17,17	12,24
7,10	5,13	12,15	9,20	17,18	12,25
7,11	5,14	12,16	9,20	17,19	13,25
7,12	6,14	12,17	10,20	17,20	13,26
8,8	5,13	12,18	10,21	18,18	13,25
8,9	5,14	13,13	9,19	18,19	13,26
8,10	6,14	13,14	9,20	18,20	14,26
8,11	6,15	13,15	10,20	19,19	14,26
8,12	6,15	13,16	10,21	19,20	14,27
9,9	6,14	13,17	10,21	20,20	14,28

Legend:

- p = number of coal characteristics tested,
- n_1 = number of fewest like signs,
- n_2 = number of most like signs,
- l = lower significance value, and
- u = upper significance value.

TABLE A2.8 Significance Values for Number of Runs

n_1, n_2	l, u	$p = 4$			
		n_1, n_2	l, u	n_1, n_2	l, u
3,5	–,–	9,10	6,15	13,18	10,22
3,6	–,–	9,11	6,16	13,19	10,22
3,7	–,–	9,12	6,16	14,14	9,21
4,4	–,–	9,13	7,16	14,15	10,21
4,5	–,8	9,14	7,17	14,16	10,22
4,6	3,–	10,10	6,16	14,17	10,22
4,7	3,–	10,11	7,16	14,18	11,23
4,8	3,–	10,12	7,17	14,19	11,23
5,5	3,9	10,13	7,17	14,20	11,24
5,6	3,10	10,14	8,18	15,15	10,22
5,7	3,10	10,15	8,18	15,16	10,23
5,8	4,–	11,11	7,17	15,17	11,23
5,9	4,–	11,12	7,18	15,18	11,24
6,6	3,11	11,13	8,18	15,19	11,24
6,7	4,11	11,14	8,19	15,20	12,24
6,8	4,12	11,15	8,19	16,16	11,23
6,9	4,12	11,16	9,19	16,17	11,24
6,10	4,12	11,17	9,20	16,18	12,24
7,7	4,12	12,12	8,18	16,19	12,25
7,8	4,12	12,13	8,19	16,20	12,25
7,9	5,13	12,14	8,19	17,17	12,24
7,10	5,13	12,15	9,20	17,18	12,25
7,11	5,14	12,16	9,20	17,19	12,25
7,12	5,14	12,17	9,21	17,20	13,26
8,8	5,13	12,18	10,21	18,18	12,26
8,9	5,14	13,13	8,20	18,19	13,26
8,10	5,14	13,14	9,20	18,20	13,27
8,11	6,15	13,15	9,21	19,19	13,27
8,12	6,15	13,16	10,21	19,20	14,27
9,9	6,14	13,17	10,22	20,20	14,28

Legend:

- p = number of coal characteristics tested,
- n_1 = number of fewest like signs,
- n_2 = number of most like signs,
- l = lower significance value, and
- u = upper significance value.

A2.1.5.6 For each coal characteristic, denote the individual differences for the n test batches of coal by $x_1, x_2, \dots, x_p, \dots, x_n$. Then calculate the following $n(n - 1)/2$ different averages of two observations:

$$(x_1 + x_2)/2, (x_1 + x_3)/2, \dots, (x_{n-1} + x_n)/2 \quad (\text{A2.1})$$

Include these $n(n - 1)/2$ averages with the original n differences, yielding a total of $w = n(n + 1)/2$ values, which are the Walsh Averages. Next, sort the Walsh Averages low to high, and index them consecutively by order. **Table A2.10** illustrates sorted Walsh Averages for the 16 moisture differences given in **Table A2.1**.

A2.1.6 *Step 5*—Determine the point estimate of the bias and the confidence interval.

A2.1.6.1 The point estimate of the bias is the median of the w (Walsh Averages). If w is an odd integer, the median is the $(w + 1)/2^{\text{th}}$ ordered value. If w is an even integer, the median is the average of the $w/2^{\text{th}}$ value and the $(w + 2)/2^{\text{th}}$ value. For the illustrative data of **Table A2.10**, w is the even integer 136; thus, the median is the average of the 136/2th, or the 68th value, which is -0.090 , and the $(136 + 2)/2^{\text{th}}$, or 69th value, which is also -0.090 . Therefore, the median and point estimate of the bias is -0.090 .

A2.1.6.2 The confidence interval is given as the closed interval $[L_d, U_d]$, where:

L_d = the d th smallest value of the Walsh Averages and
 U_d = the d th largest value of the Walsh Averages.

A2.1.6.3 The value of d is read from **Table A2.11** using the appropriate values of n , the number of test batches, and p , the number of coal characteristics tested. Using the illustrative data of **Table A2.10**, moisture, dry ash, and dry sulfur were tested with 16 batches of coal; thus, $p = 3$, $n = 16$, and the table value of d is the integer 22. Therefore, L_d is the 22nd value of **Table A2.10** or -0.265 , and U_d is the $[n(n + 1)/2] + 1 - d = 115$ th value or 0.035 . The closed confidence interval for moisture then is $[-0.265, 0.035]$.

A2.2 Interpretation of Nonparametric Results and Adequacy of Data

A2.2.1 Concluding statements for the test are made as follows:

A2.2.1.1 *Statement A*—If a chance error which, before the test had a maximum probability of occurring equal to no more than about 1 in 20, did not occur, biases of mechanically collected samples against reference samples lie within the closed intervals given below.

Moisture	$L_d(m) \leq \beta(m) \leq U_d(m)$
Dry ash	$L_d(da) \leq \beta(da) \leq U_d(da)$
(continue with other characteristics tested)	

TABLE A2.9 Significance Values for Number of Runs

n_1, n_2	l, u	$p = 5$			
		n_1, n_2	l, u	n_1, n_2	l, u
3,5	–,–	9,10	6,15	13,18	10,22
3,6	–,–	9,11	6,16	13,19	10,23
3,7	–,–	9,12	6,16	14,14	9,21
4,4	–,–	9,13	7,17	14,15	9,22
4,5	–,9	9,14	7,17	14,16	10,22
4,6	3,–	10,10	6,16	14,17	10,23
4,7	3,–	10,11	6,17	14,18	10,23
4,8	3,–	10,12	7,17	14,19	11,23
5,5	3,9	10,13	7,18	14,20	11,24
5,6	3,10	10,14	7,18	15,15	10,22
5,7	3,10	10,15	8,18	15,16	10,23
5,8	3,–	11,11	7,17	15,17	11,23
5,9	4,–	11,12	7,18	15,18	11,24
6,6	3,11	11,13	7,18	15,19	11,24
6,7	4,11	11,14	8,19	15,20	12,25
6,8	4,12	11,15	8,19	16,16	11,23
6,9	4,12	11,16	8,20	16,17	11,24
6,10	4,–	11,17	9,20	16,18	11,24
7,7	4,12	12,12	8,18	16,19	12,25
7,8	4,13	12,13	8,19	16,20	12,25
7,9	5,13	12,14	8,20	17,17	11,25
7,10	5,14	12,15	9,20	17,18	12,25
7,11	5,14	12,16	9,21	17,19	12,26
7,12	5,14	12,17	9,21	17,20	13,26
8,8	5,13	12,18	9,21	18,18	12,26
8,9	5,14	13,13	8,20	18,19	13,26
8,10	5,14	13,14	9,20	18,20	13,27
8,11	6,15	13,15	9,21	19,19	13,27
8,12	6,15	13,16	9,21	19,20	13,28
9,9	5,15	13,17	10,22	20,20	14,28

Legend:

- p = number of coal characteristics tested,
- n_1 = number of fewest like signs,
- n_2 = number of most like signs,
- l = lower significance value, and
- u = upper significance value.

where $\beta(m)$ and $\beta(da)$ denote moisture bias and dry ash bias, respectively.

Use Statement B or Statement C (below), as appropriate.

A2.2.1.2 Statement B—The confidence interval for each coal characteristic includes the value zero; thus, this test offers insufficient evidence to reject a hypothesis of no bias of system samples against reference samples.

A2.2.1.3 Statement C—The confidence interval(s) for (insert here the name of one or more characteristics) does not (do not) cover the value zero; thus, there is evidence of bias of mechanical system samples against reference samples. The sample estimate of the bias is (report the point estimate(s) as determined by [A2.1.6.1](#)).

A2.2.2 For the example test data given in [Tables A2.1-A2.3](#), the concluding statements are as follows:

A2.2.2.1 If a chance error with a maximum probability before the test of no more than about 1 out of 20 of occurring, did not occur, biases of mechanically collected samples against reference samples lie within the closed intervals given below:

Moisture	$-0.265 \leq \beta(m) \leq 0.035$
Dry ash	$-0.020 \leq \beta(da) \leq 0.120$
Dry sulfur	$-0.005 \leq \beta(ds) \leq 0.020$

where $\beta(m)$, $\beta(da)$, and $\beta(ds)$ represent moisture, dry ash, and dry sulfur biases, respectively.

A2.2.2.2 The confidence interval for each coal characteristic includes the value zero; thus, this test offers insufficient

TABLE A2.11 Sorted Walsh Averages for Moisture Illustrative Data

1	-1.170	35	-0.190	69	-0.090	103	0.000
2	-0.775	36	-0.185	70	-0.080	104	0.000
3	-0.725	37	-0.185	71	-0.070	105	0.000
4	-0.710	38	-0.180	72	-0.070	106	0.010
5	-0.690	39	-0.175	73	-0.070	107	0.010
6	-0.655	40	-0.170	74	-0.070	108	0.010
7	-0.630	41	-0.170	75	-0.070	109	0.010
8	-0.630	42	-0.165	76	-0.065	110	0.020
9	-0.610	43	-0.155	77	-0.060	111	0.020
10	-0.595	44	-0.150	78	-0.060	112	0.025
11	-0.585	45	-0.150	79	-0.055	113	0.035
12	-0.585	46	-0.150	80	-0.055	114	0.035
13	-0.575	47	-0.150	81	-0.050	115	0.035
14	-0.550	48	-0.140	82	-0.045	116	0.035
15	-0.505	49	-0.140	83	-0.045	117	0.045
16	-0.460	50	-0.140	84	-0.045	118	0.055
17	-0.380	51	-0.135	85	-0.045	119	0.055
18	-0.330	52	-0.130	86	-0.045	120	0.070
19	-0.315	53	-0.130	87	-0.035	121	0.070
20	-0.295	54	-0.125	88	-0.035	122	0.080
21	-0.280	55	-0.125	89	-0.035	123	0.080
22	-0.265	56	-0.115	90	-0.035	124	0.080
23	-0.260	57	-0.115	91	-0.025	125	0.080
24	-0.250	58	-0.115	92	-0.025	126	0.090
25	-0.245	59	-0.115	93	-0.025	127	0.100
26	-0.235	60	-0.110	94	-0.020	128	0.115
27	-0.235	61	-0.105	95	-0.015	129	0.115
28	-0.230	62	-0.105	96	-0.015	130	0.125
29	-0.215	63	-0.105	97	-0.010	131	0.125
30	-0.210	64	-0.095	98	-0.010	132	0.135
31	-0.210	65	-0.095	99	-0.010	133	0.160
32	-0.200	66	-0.090	100	-0.010	134	0.160
33	-0.195	67	-0.090	101	0.000	135	0.205
34	-0.190	68	-0.090	102	0.000	136	0.250

TABLE A2.12 Counting Value d

n	$p = 1$	$p = 2$	$p = 3$	$p = 4$	$p = 5$
10	9	6	5	4	4
11	11	9	7	6	6
12	14	11	10	9	8
13	18	14	12	11	10
14	22	18	16	14	14
15	26	21	19	18	17
16	30	25	22	20	18
17	35	29	26	24	22
18	41	34	31	28	26
19	47	39	36	33	31
20	53	45	41	38	36
21	60	51	47	44	42
22	67	58	53	49	47
23	74	64	59	56	54
24	82	72	66	63	60
25	90	79	74	70	67
26	98	87	81	77	74
27	107	96	90	85	82
28	116	105	98	93	90
29	126	114	107	102	99
30	137	124	116	111	108
31	147	134	126	120	117
32	159	144	136	130	127
33	170	155	147	141	137
34	182	166	158	151	147
35	195	178	169	162	158
36	208	190	181	174	169
37	221	203	193	186	181
38	235	216	206	198	193
39	249	229	219	211	206
40	264	243	232	224	219

evidence to reject a hypothesis of no bias of system samples against reference samples.

A2.2.3 It can turn out that one or more confidence intervals given by Statement A of A2.2.1.1 will be too wide for the test to be useful. For example, if the closed interval for moisture turns out to be $[-0.450, +0.115]$, whereas a moisture bias of -0.40 , is of practical significance, one will conclude there is a need to reduce the width of the confidence interval. Note that the width of the interval is inversely proportional (approximately) to the square root of the number of paired differences. If the variance of paired differences is so large that it is not economically feasible to reduce the width of the confidence interval sufficiently by continuing the test, one might be able to repeat the test under more favorable conditions. Taking more reference increments per test batch, or employing some other means to reduce the variance of differences between the reference and system measurements should be evaluated if the aforementioned situation does occur and complicates the evaluation process.

A2.3 Parametric Statistical Procedures

A2.3.1 The statistical procedures produce, in effect, a list of all bias values that are plausible given the experimental bias test data. This list is in the form of a one-dimensional confidence interval if only one characteristic is selected. If several characteristics are selected, the list is in the form of an n -dimensional confidence region. This confidence interval or region can be checked against a largest tolerable bias (LTB) interval or region, which represents what is acceptable to both producer and consumer, and which may be agreed upon before the bias test is performed.

A2.3.2 *Using Student's t -Statistic for Bias Test Data*—Student's t -statistic may be used to quantify the uncertainty in bias tests when only one quality parameter, for example, ash, sulfur, Btu, specific size fraction, and so forth is to be assessed. This single parameter must be selected beforehand from among all data to be produced by the laboratory. A confidence interval is constructed for the unknown bias that summarizes all the information contained in the bias test data pairs. The following steps outline the procedure.

NOTE A2.1—The parameter(s) not selected for bias test purposes may be helpful to the lab for internal quality control, or may be used to diagnose the likely cause(s) of bias in the single selected parameter, or may be of value for other purposes. Such uses of the not-selected parameters are beyond the scope of this Practice.

A2.3.2.1 Before performing the bias test, all interested parties should agree to an interval whose upper and lower bounds represent the limits to a negligible bias. This interval will be referred to as the LTB and will be based on operational and economic considerations. If the bias can be reasonably shown to fall within the LTB interval, the sampling system will be considered to be practically unbiased. For the bias test to have a chance to lead to the correct action, it is important that the LTB interval accurately define the limits of an acceptable bias. An LTB that is too wide will increase the chances of allowing a seriously biased sampling system to go uncorrected, while an LTB that is too narrow will increase the chances of making unnecessary sampling system modifications. Once the

LTB is chosen, it should not be revised after the data is collected just so the sampling system can be declared acceptable.

A2.3.2.2 Let $x_r(i)$ represent the quality of the i^{th} reference (stopped-belt) increment and $x_a(i)$ represent the quality of the i^{th} system sample and $d(i) = x_a(i) - x_r(i)$ the corresponding difference, for $i = 1, 2, \dots, n$ where n is the number of sample pairs. Calculate the following statistics:

$$\bar{d} = \frac{\sum_{i=1}^n d(i)}{n} \quad (\text{A2.2})$$

$$s^2 = \frac{\sum_{i=1}^n d(i)^2 - n\bar{d}^2}{(n-1)} \quad (\text{A2.3})$$

$$s_{\bar{d}} = \frac{s}{\sqrt{n}} \quad (\text{A2.4})$$

A2.3.2.3 Here, \bar{d} is the estimated bias and mean difference between the reference and system samples, s^2 is the estimated variance of these differences, s (the square root of s^2) is the estimated standard deviation of the differences, and $s_{\bar{d}}$ is the estimated standard deviation of the mean difference \bar{d} . ($s_{\bar{d}}$ also is referred to as the estimated standard error of the mean difference \bar{d} .)

A2.3.2.4 Calculate either the 95 or the 99 % confidence interval:

$$\bar{d} \pm t_{1-\alpha/2, n-1} s_{\bar{d}} \quad (\text{A2.5})$$

where α is the univariate risk that the confidence interval does not cover the unknown level of bias, $(1 - \alpha)100$ % is the percent confidence interval, $n - 1$ is the value of the degrees of freedom of the estimate, and t is read from a table of Student's t .

A2.3.2.5 Compare the calculated confidence interval with the LTB interval. There are three possible results:

(a) If the confidence interval falls entirely within the LTB interval declare the bias to be negligible and the sampling system acceptable.

(b) If the confidence interval falls entirely outside the LTB interval, declare the bias non-negligible and the sampling system unacceptable.

(c) If the LTB interval and the confidence interval overlap, declare the bias test inconclusive. In this case, there is not enough evidence to conclude the sampling system to be acceptable and more bias test increments should be collected or a new bias test with more sets of data must be performed to resolve the problem.

A2.3.3 *Using Hotelling's T^2 Test for Multivariate Bias Test Data*—When more than one measurement is made on each increment and bias results are desired for all quality parameters, the Student's t -test should no longer be used. The multivariate analog of the Student's t -test is known as Hotelling's T^2 statistic. This multivariate method can be used to produce a confidence region that correctly defines all plausible parameter bias values, those that are supported by the actual bias test data.

A2.3.3.1 The following four steps correspond to those for Student's *t*-test:

(a) A multidimensional LTB region should be established for the *p* quality parameters for which biases are to be estimated. If the number of quality parameters is less than or equal to three, the region can be graphed. For example, if *p* = 2, then the region could be the area inside a rectangle or an ellipse. If *p* = 3, then the region could be a prism or ellipsoid. Ellipsoidal regions exclude jointly large biases (regardless of direction, that is, negative or positive), while rectangular and prismatic regions do not. (When *p* = 1, the region is a line interval so that the choice does not exist when using Student's *t* method.) Ellipsoidal regions of *p* dimensions are better suited to being LTB regions. In general, the *p*-dimensional LTB is given by:

$$\sum x_i^2/m_i^2 \leq 1 \quad (\text{A2.6})$$

where x_i is the coordinate for the i^{th} parameter and m_i is the largest tolerable bias (irrespective of sign) for the i^{th} parameter. As an example, suppose *p* = 2 and bias estimates are desired for ash and Btu. Suppose further that a negligible ash bias is within $\pm 0.15\%$ ash and a negligible Btu bias is within ± 10 Btu. If a rectangular LTB region were used, this would be specified as follows:

$$\begin{aligned} -0.15\% \text{ ash} &\leq \text{ash bias} \leq 0.15\% \text{ ash and} \\ -10 \text{ Btu} &\leq \text{Btu bias} \leq 10 \text{ Btu} \end{aligned}$$

NOTE A2.2—This would allow the ash and Btu bias simultaneously to be as bad as -0.15% ash and -10 Btu, respectively. Other extremes also are possible. If a more appropriate two-dimensional ellipsoidal LTB region (inequality Eq A2.10) were used, the LTB region would be specified as follows:

$$x_1^2/(0.15\% \text{ ash})^2 + x_2^2/(10 \text{ Btu})^2 \leq 1 \quad (\text{A2.7})$$

where x_1 is the coordinate for the ash bias and x_2 is the coordinate for the Btu bias.

This elliptical region does not include simultaneously large biases in both parameters. For example, not only would a simultaneous 0.15% ash bias and 10 Btu bias not be tolerated, even a simultaneous 0.11% ash bias and 7.5 Btu bias would not be tolerated. As the ash bias approaches 0.15% ash, the Btu bias must approach 0 Btu. Conversely, as the Btu bias approaches 10 Btu, the ash bias must approach 0% ash.

(b) Let $x_r(i, j)$ represent the j^{th} quality of the i^{th} reference sample and $x_a(i, j)$ represent the j^{th} quality of the i^{th} actual system sample, and $d(i, j) = x_a(i, j) - x_r(i, j)$ the corresponding difference for $i = 1, 2, \dots, n$ where *n* is the number of increment pairs and $j = 1, 2, \dots, p$ where *p* is the number of quality parameters. Calculate the following statistics for each quality parameter *j*:

$$\bar{d}_j = \frac{\sum_{i=1}^n d(i, j)}{n} \quad (\text{A2.8})$$

$$s_j^2 = \frac{\sum_{i=1}^n d(i, j)^2 - n\bar{d}_j^2}{(n-1)} \quad (\text{A2.9})$$

Here \bar{d}_j is the mean for the j^{th} quality parameter and s_j^2 is the variance for the j^{th} quality parameter. Except for the extra subscript *j* used to denote a specific quality parameter, Eq

A2.11 is equivalent to Eq A2.2, and Eq A2.12 is equivalent to Eq A2.3. Also, for every pair of quality parameters *j* and j' , $j \neq j'$, compute:

$$s_{jj'} = \frac{\sum_{i=1}^n d(i, j)d(i, j') - n\bar{d}_j\bar{d}_{j'}}{(n-1)} \quad (\text{A2.10})$$

Here $s_{jj'}$ is the covariance between quality *j* and quality j' where $j \neq j'$. Create the following (*p* × 1) mean vector:

$$\bar{D}' = [\bar{d}_1 \bar{d}_2 \dots \bar{d}_p] \quad (\text{A2.11})$$

where D' denotes the transpose of a vector or matrix *D*. Create the following (*p* × *p*) variance-covariance matrix *S*:

$$S = \begin{bmatrix} s_{11}^2 & s_{12} & \dots & s_{1p} \\ s_{21} & s_{22}^2 & \dots & s_{2p} \\ | & | & \backslash & | \\ s_{p1} & s_{p2} & \dots & s_p^2 \end{bmatrix} \quad (\text{A2.12})$$

NOTE A2.3— $s_{jj'} = s_{j'j}$. In all, *p* variances and $p(p-1)/2$, covariances must be calculated. The correlation $r_{jj'}$ between quality parameter *j* and j' can be estimated as follows:

$$r_{jj'} = \frac{r_{jj'}}{s_j s_{j'}} \quad (\text{A2.13})$$

The percentage of variance accounted for (or explained) by parameter *j* for parameter j' is given by:

$$100\% \times (r_{jj'})^2 \quad (\text{A2.14})$$

(c) Let $X^t = [x_1 x_2 \dots x_n]$ represent the coordinates for the parameter biases. Then, a $100(1 - \alpha)\%$ confidence region is given by:

$$n(\bar{D} - X)' S^{-1} (\bar{D} - X) \leq T_{p, n-1}^2(\infty) = \frac{(n-1)p}{(n-p)} F_{p, n-p}(\infty) \quad (\text{A2.15})$$

where S^{-1} is the matrix inverse of *S* and $T_{p, n-1}^2(\infty)$ is taken from the T^2 table for *p* and *n* - 1 df, or alternatively, $F_{p, n-p}(\infty)$ is taken from the more easily available *F* table with *p* and *n* - *p* df.

Alternatively, without using matrix computations, the left-most expression of inequality Eq A2.18 can be calculated as follows:

$$n \left[\sum \delta_j (\bar{d}_j - x_j)^2 + 2 \sum \sum \delta_{jj'} (\bar{d}_j - x_j) (\bar{d}_{j'} - x_{j'}) \right] \quad (\text{A2.16})$$

where $j \neq j'$ and

$$S = \begin{bmatrix} \delta_{11} & \delta_{12} & \dots & \delta_{1p} \\ \delta_{21} & \delta_{22} & \dots & \delta_{2p} \\ | & | & \backslash & | \\ \delta_{p1} & \delta_{p2} & \dots & \delta_p \end{bmatrix} \quad (\text{A2.17})$$

The remaining task is to determine the relationship between the confidence region and the LTB region.

(d) If *p* is 2 or 3, the confidence region and the LTB region can be graphed and easily visualized. If *p* is 4 or greater, it can mathematically be determined whether the regions overlap or not but is more difficult to visualize. As for the univariate case, there are three possible results:

(1) If the confidence region falls entirely within the LTB region, declare the bias to be negligible and the sampling system acceptable.

(2) If the confidence region falls entirely outside the LTB region, declare the bias non-negligible and the sampling system is unacceptable. The sampling system must be scrutinized to determine the cause of the bias and then corrected and retested.

(3) If the LTB region and the confidence region overlap, declare the bias test inconclusive. In this case, there is not enough evidence to conclude the sampling system is acceptable and more bias test increments must be collected or a new bias test with more increments must be performed to resolve the problem.

A2.3.3.2 Example of Hotelling's T^2 Statistics—A bias test was planned for a mechanical coal sampling system at the mine loadout. Before the bias test was performed, the producer and consumer agreed that the sampling system was acceptable (produced a negligible bias) if it could be shown that almost definitely:

$$x_1^2/(0.15\% \text{ ash})^2 + x_2^2/(10 \text{ Btu})^2 \leq 1 \quad (\text{A2.18})$$

where x_1 is the coordinate for ash bias, and x_2 is the coordinate for Btu bias and is based on inequality Eq A2.9. It was further agreed that this would be accomplished if the 95 % confidence region falls entirely within the above LTB region. The data shown in Table A2.12 was collected when the bias test was performed. Dry ash differences are denoted by subscript $j = 1$, and as-received Btu differences by subscript $j = 2$. The number of increment pairs n is equal to 30. Then, using Eq A2.11, the mean differences $\bar{d}_1 = -0.46$ and $\bar{d}_2 = 46$, and therefore, by Eq A2.14.

$$\bar{D}' = [-0.46 \ 46] \quad (\text{A2.19})$$

TABLE A2.15 Actual Minus Stopped Belt Differences Collected in a Bias Test

Pair	Actual–Stopped Belt Dry Ash (%)	As-Received Btu
1	-1.13	114
2	-0.81	182
3	-0.01	10
4	0.07	58
5	-0.37	4
6	-0.64	57
7	0.06	53
8	-0.67	196
9	-0.82	108
10	-0.61	-40
11	-1.24	209
12	0.00	50
13	-0.25	77
14	-0.44	66
15	-0.79	140
16	-1.39	115
17	-1.26	177
18	-0.10	-71
19	-0.53	151
20	0.20	-32
21	-0.10	-31
22	-0.39	75
23	-1.05	121
24	-1.16	78
25	0.58	-123
26	0.16	-54
27	-1.54	121
28	0.85	-207
29	0.02	-58
30	-0.37	-165

Using Eq A2.12, the variances are $s_1^2=0.35$ and $s_2^2=112651$. Using Eq A2.13, the covariance $s_{12} = -47.5$. (The correlation between dry ash and as received Btu can be calculated as the covariance divided by the square root of the product of the variances. This yields $r_{12} = r_{21} = -0.76$.)

The variance-covariance matrix (Eq A2.15) then is:

$$s = \begin{bmatrix} 0.35 & -47.50 \\ -47.50 & 11265.10 \end{bmatrix} \quad (\text{A2.20})$$

and its inverse (Eq A2.20)

$$s^{-1} = \begin{bmatrix} 6.679434 & 0.028164 \\ 0.028164 & 0.000208 \end{bmatrix} \quad (\text{A2.21})$$

Using inequality Eq A2.18, the 95 % confidence region is:

$$30[6.679434(-0.46 - x_1)^2 + 2(0.028164)(-0.46 - x_1)(46 - x_2) + 0.000208(46 - x_2)^2] \leq 6.92 \quad (\text{A2.22})$$

given that $T_{2,29}^2(0.05) = 6.92$.

Alternatively, $F_{2,28}(0.05) = 3.34$ so that (from right-hand side of inequality) Eq A2.18 is as follows:

$$\frac{(30 - 1)2}{(30 - 2)} \times 3.34 = 6.92 \quad (\text{A2.23})$$

The LTB region (inequality Eq A2.21) and the 95 % confidence region (inequality Eq A2.26) are computed. The fact that these regions do not overlap and the confidence region falls entirely outside of the LTB region indicates almost without doubt the sampling system is unacceptable according to the test agreed to by the producer and the consumer.

For illustration purposes, suppose that instead of the previous bias test, a bias test was planned which would only measure as received Btu. Suppose further that the following LTB interval was agreed upon before the start of the bias test:

$$-10 \text{ Btu} \leq \text{Btu bias} \leq 10 \text{ Btu}$$

and that the producer and the consumer would consider the bias to be negligible if the 95 % confidence interval falls entirely within the LTB interval.

Assume that the same as received Btu difference data was collected. Using Eq A2.2, the mean Btu difference \bar{d} is 46 Btu. Using Eq A2.3, the variance s^2 is 11 265.1 (Btu)². The standard error for the mean difference s_d (Eq A2.4) is 19.38 (Btu)². The 95 % confidence interval (Eq A2.8) then is as follows:

$$46 \pm 2.045(19.38)$$

or

$$6.37 \text{ to } 85.63 \text{ Btu}$$

In this case, the bias test is declared inconclusive because the LTB interval and the 95 % confidence interval overlap from 6.37 to 10 Btu. More increment pairs must be collected so that a conclusion can be reached as to whether the sampling system is almost without doubt either acceptable or unacceptable when measuring only Btu.

A2.3.4 Discussion of Results:

A2.3.4.1 Part of the same data set was used to illustrate the computations for two different bias tests. The univariate bias test only used the as-received Btu data and reached a very different conclusion (bias test inconclusive) compared to the

multivariate bias test (sampling system unacceptable). In part, the reason for the difference is the additional dry ash information available to the multivariate test. Although had just dry ash been collected and submitted to a univariate bias test procedure, both the univariate and multivariate procedures would have happened to declare the sampling system unacceptable. A properly applied multivariate bias test will always yield more information, and hence, be more likely to lead to the correct action than a univariate bias test procedure applied to a single parameter. (The only exception would be the unlikely case where the several parameters are perfectly correlated either -1 or $+1$ correlations. In this case, there really is only one parameter and the univariate and multivariate test procedures must reach the same conclusion.)

A2.3.4.2 Suppose both dry ash and as-received Btu were both collected and univariate tests applied separately to each parameter. This would be incorrect for several reasons. First, the correlation (in this case a moderate correlation of -0.76) between the parameters would be ignored which results in a loss of information. The correlation or lack of it between the measured parameters supplies information on which pairs of values are more or less likely. The separate repeated univariate tests implicitly generate a rectangular confidence region, which is too small, and the actual confidence percentage is much less than the percentage used to construct the individual intervals. That is, if separate repeated 95 % confidence intervals are constructed for p parameters, the actual joint confidence region may only be a 50 % region, not 95 %. Also, because the correlation is ignored, the orientation of the confidence region would incorrectly include some less plausible bias values and exclude more plausible values. Finally, the appropriate multidimensional confidence region supplied by the multivariate T^2 method gives the most complete information available on the likely value of the joint bias. The use of repeated univariate confidence intervals in place of the appropriate multivariate confidence region will lead to a greater likelihood of incorrect conclusions and also to the greater likelihood of inconclusive bias tests, even while the multivariate confidence region would have lead to a definitive conclusion on sampler acceptability.

A2.3.4.3 It is important to notice what happens if the true (but unknown) bias is near either the upper or lower LTB limit (either inside or outside the interval or region). In this case, the number of increment pairs needed to resolve whether the sampling device is, or is not acceptable may become impractically large. The conclusion, simply, is that the sampling device is close to the limit and it will be virtually impossible to determine whether it is technically acceptable. The conservative approach, at some point, would be to investigate the sampling system to try to discover flaws in the design or operation of the device, or both, that have inadvertently been overlooked, and then correct them rather than continue bias testing the existing system. The system can be subjected to another bias test after corrections are made. Because the bias test is used to estimate an unknown potential bias, there is no way to insure avoiding this problem.

A2.3.4.4 The essential determination in a bias test is to see if the plausible values of the bias (as defined by a confidence interval or region) fall entirely within what is acceptable (as

defined by the LTB interval or region). When measuring more than one quality parameter (excluding size fractions), it is not very meaningful to try to place individual simultaneous confidence intervals around each parameter bias estimate (although simultaneous individual confidence intervals can easily be constructed). The multivariate confidence region is a single confidence region that correctly handles inferences for more than one parameter. Essentially, the multivariate confidence region is a list of all plausible parameter biases given the bias test data actually collected. The shape and orientation of the ellipsoidal region and its location with respect to the LTB region provides all the information that is available from the bias test procedure.

A2.3.4.5 Both the univariate Student's t method and the multivariate Hotelling's T^2 method make some statistical assumptions about the data collected. Both methods assume that the difference observations are statistically independent. In the multivariate method, the difference observations are vectors. The vector observations are assumed statistically independent. This means, along with the normality assumption to be discussed in the Appendix, that there is no correlation across observations. Both methods also assume that the data are normally distributed. In the multivariate case, a multivariate normal distribution is assumed. Both the statistical independence assumption and the normality assumption can and should be examined, although the details are beyond the scope of this practice.

A2.4 Combined-Variance for Intrapphase Test

A2.4.1 Intrapphase statistical analysis is conducted using Student's t -test for the paired difference between two means. This analysis tests the hypothesis that the mean difference between pairs of related elements is statistically equivalent to zero. This statistic assumes normally distributed differences. If the calculated t value is equal to or exceeds the value of t for the appropriate confidence level and degrees of freedom taken from a t table, then the difference is determined to be statistically significant.

A mechanical coal-sampling system is essentially a linear process. This means that the difference between a product's characteristic at the beginning and the end of the process must equal the sum of the differences in the characteristic between all intermediate steps. Algebraically, this is shown by the following equation:

$$(y_1 - y_2) + (y_2 - y_4) = y_1 - y_4 \quad (\text{A2.24})$$

A2.4.1.1 Because differences in values are being dealt with and not the absolute values themselves, this analysis can be extended across phase boundaries, assuming that equivalent reference points are used on either side of the phase boundary. In these two-phased tests of mechanical coal-sampling systems, the assumption is made that the primary subsample and the surrogate reference subsample, even though taken at different times, are equivalent; therefore, the mean difference between the endpoints of the "A" phase can be added to the mean difference between the endpoints of the "B" phase to arrive at an overall mean difference for the system. It is recognized, however, that any statistical analysis is incomplete without some measure of confidence. The classic method of

determining confidence levels involves calculating the range about the mean determined by multiplying a factor (the Student's *t*) by the standard error of the estimate. The standard error of each phase can be determined, but as they involve the square root function, they can not be added directly because:

Given that the Standard Error ≈ Standard Deviation = (A2.25)

$$\sqrt{\text{variance}}, \sqrt{\text{variance}_a} + \sqrt{\text{variance}_b} = \sqrt{\text{variance}_a + \text{variance}_b}$$

However, variances, as the square of the standard deviation, are additive:

$$(\text{variance}_a) + (\text{variance}_b) = (\text{variance}_a + \text{variance}_b) \quad (\text{A2.26})$$

Therefore, a technique known as pooling variances is used to develop a pooled variance and thereby, a pooled standard deviation. This pooled standard deviation, when divided by the

square root of the number of sets, becomes the standard error, which may be multiplied by the appropriate *t* value and used to estimate the confidence interval. Deriving an appropriate denominator for massing variances and for calculating the standard error becomes somewhat problematic. If sample sizes are equivalent, and if the population variances are equivalent, it is permissible to calculate the degrees of freedom by summing the sample sizes and subtracting the number of phases (**1**).⁴ If sample sizes are unequal, a modification to this method is required. The reader is referred to a statistics textbook for a discussion of the Welch approximation or the Satterthwaite approximation.

⁴ The boldface numbers in parentheses refer to the list of references at the end of this standard.

**A3. SELECTION OF TEST BATCH SIZE
(SECTION D – BIAS TESTING)**

A3.1 The following criteria are recommended for selecting the mass of coal from which reference and system samples are to be drawn.

A3.2 The laboratory sample prepared from the mechanical system sample collected during processing of a test batch should be approximately equal in mass to the laboratory sample prepared from the reference sample; thus, the test batch size must be large enough to assure that the system collects a sample of sufficient size to meet this condition.

A3.3 When stopped-belt increments are used as the reference, it is recommended that the minimum time interval

between collection of successive reference increments from a test batch of coal be at least 20 min to avoid interrupting the sampling system's moisture equilibrium. This 20-min time period may be decreased if it does not adversely affect the sampling system's moisture equilibrium. Before beginning the test, approval of the conveyor belt-stopping procedure should be obtained from management responsible for the material handling system.

A3.4 Where the time for processing a lot of coal is on the order of 1 h or less, consideration should be given to making the test batch size equal to the lot size.

A4. BIAS TESTING A MECHANICAL SAMPLING SYSTEM
TABLE A4.1 ASTM D6518 Bias Testing a Mechanical Sampling System

 Terms are referenced in Sections 38, 39, and Annex A2^A

	Data Structure ^A	Variables	Statistic	Method	Special Requirements	Confidence Interval	Bias Affirmed	Bias Estimate ^A
Parametric	Paired Increment	Univariate	Student's <i>t</i>	Hypothesis Test	Pretest Selection of LTB	Linear	LTB not within Confidence Interval	Arithmetic Average
		Multivariate	Hotelling T ²	Hypothesis Test	Pretest Selection of LTB Set	Elliptical	LTB not within Confidence Interval	Arithmetic Average
	Paired Test Batch	Univariate	Student's <i>t</i>	Hypothesis Test	Pretest Selection of LTB	Linear	LTB not within Confidence Interval	Arithmetic Average
		Multivariate	Hotelling T ²	Hypothesis Test	Pretest Selection of LTB Set	Elliptical	LTB not within Confidence Interval	Arithmetic Average
Nonparametric	Paired Increment	Univariate	Wilcoxon Signed Rank Test	Parameter Estimation	Post test Selection of LTB Optional A2.2.3	Linear	Zero not within Confidence Interval	Median of Walsh Averages
		Multivariate	Wilcoxon Signed Rank Test	Parameter Estimation	Post test Selection of LTB Set Optional A2.2.3	Rectangular	Zero not within Confidence Interval	Median of Walsh Averages
	Paired Test Batch	Univariate	Wilcoxon Signed Rank Test	Parameter Estimation	Post test Selection of LTB Optional A2.2.3	Linear	Zero not within Confidence Interval	Median of Walsh Averages
		Multivariate	Wilcoxon Signed Rank Test	Parameter Estimation	Post test Selection of LTB Set Optional A2.2.3	Rectangular	Zero not within Confidence Interval	Median of Walsh Averages

^A Table was editorially corrected in January 2007.

A5. TEST METHOD FOR ESTIMATING THE OVERALL VARIANCE FOR INCREMENTS

A5.1 Scope

A5.1.1 This test method describes the procedure for estimating the overall variance for increments of one fixed mass of a given coal. It is applicable to mechanical sampling when there is no need to explore system and random variance components, but there is a need for obtaining the overall variance for increments (the size of increments is dictated by the sampling equipment).

A5.2 Procedure

A5.2.1 The following procedure should be used to determine the overall variance of increments:

A5.2.2 Collect two series of individual increments at widely spaced intervals, for example, a series of ten increments, two each day for five days, followed by a second series of ten collected in similar fashion. Both series must be from the same coal.

A5.2.3 Collect each increment by using as much of the equipment and procedure used in routine sampling operations as possible. Remove the individual increment from the sampling system without mixing with or contaminating by any other increment. Where possible, allow it to pass through any mechanical crusher or subsampler, or both, which is located in the system before the point of blending with other increments.

A5.2.4 Then weigh the individual increment (if desired for record purposes) and reduce to a laboratory sample by procedures identical as possible to those used in the routine preparation and reduction of gross samples.

A5.2.5 Analyze the sample for the constituents for which the variance calculations are to be made. Usually sampling specifications are based on dry ash, but where total moisture or as-received Btu is of particular concern, the analyses should be made for these.

A5.3 Calculation

A5.3.1 For each series, compute a variance value from the analyses of the ten increments as follows:

$$s^2 = (\Sigma x^2 - (\Sigma x)^2/n)/(n - 1) \quad (\text{A5.1})$$

where:

s^2 = variance value for series,

Σx^2 = sum of squares of ash results,
 $(\Sigma x)^2$ = square of the sum of ash results, and
 n = number of individual ash results in the series.

A5.3.2 For the two series, the ratio of the larger variance to the smaller should not exceed the value given in [Table A5.1](#), Column 2. If they differ by less than this amount, the variances are combined to give the estimated overall increment variance for the coal as follows:

$$s_o^2 = C[(s_1^2 + s_2^2)/2] \quad (\text{A5.2})$$

where:

s_o^2 = probable maximum value of the overall variance for increments,

C = factor from [Table A5.1](#), Column 3, corresponding to the number of increments per set,

s_1^2 = s^2 from first series, and

s_2^2 = s^2 from second series.

A5.3.3 If the ratio of the larger variance to the smaller does give a greater value than the [Table A5.1](#), Column 2 value, the two series are to be considered in a single set of increments, and another set equal to this enlarged set is to be taken. For example, if originally 2 sets of 10 increments were taken, these would be combined to give a set of 20. Then an additional set of 20 increments would be collected, giving 2 sets of 20 increments each. Variance values are computed for the two new series and the test is repeated using the appropriate factors given in [Table A5.2](#). If these results have a ratio which is less than the appropriate value in Column 2 of [Table A5.1](#), they are combined by using [Eq A5.2](#) and used as the new variance for increments.

A5.3.4 *Example*—The example given in [Table A5.2](#) illustrates the computation of the overall variance for increments, s_o^2 . Two series of ten increments each are used.

TABLE A5.1 Variance Ratio Limit Values

1	2	3
Increment per Set	Variance Ratio Limit	"C" Factor
10	3.18	1.92
20	2.17	1.53
30	1.86	1.40
40	1.70	1.33
50	1.61	1.29

TABLE A5.2 Determination of the Overall Variance for Increments^A

Series 1			Series 2		
Increment Number, <i>n</i>	Dry Ash ^B (<i>x</i>)	(Dry Ash) ^{2B} (<i>x</i>) ²	Increment Number, <i>n</i>	Dry Ash ^B (<i>x</i>)	(Dry Ash) ^{2B} (<i>x</i>) ²
1	4.17	17.3889	11	3.07	9.4249
2	3.62	13.1044	12	4.88	23.8144
3	1.79	3.2041	13	5.14	26.4196
4	4.37	19.0969	14	3.63	13.1769
5	4.64	21.5296	15	3.17	10.0489
6	7.03	49.4209	16	7.20	51.8400
7	6.27	39.3129	17	3.52	12.3904
8	3.91	15.2881	18	0.87	0.7569
9	6.04	36.4816	19	0.72	0.5184
10	4.18	17.4724	20	4.78	22.8484
Sum	46.02	232.2998	Sum	36.98	171.2388

^A This example involves increment masses in the approximate range from 45 to 90 kg (100 to 200 lb).

^B 10 % ash was subtracted from each of the ash results to simplify the calculations.

$$s^2 = (\Sigma(x)^2 - (\Sigma x)^2/n)/(n - 1)$$

Series 1:

$$s_1^2 = (232.2998 - (46.02)^2/10)/9 = 2.2795$$

Series 2:

$$s_2^2 = (171.2388 - (36.98)^2/10)/9 = 3.8319$$

Variance ratio limit from **Table A5.1** = 3.18.

Variance ratio for two test series:

$$s_2^2/s_1^2 = 3.8319/2.2795 = 1.68 < 3.18$$

Since the computed value for the ratio is less than 3.18, variances are combined to give an estimate of the overall variance for increments, s_o^2 :

$$s_o^2 = [1.92(2.2795 + 3.8319)]/2 = 5.867$$

APPENDIXES

(Nonmandatory Information)

**X1. TYPICAL MECHANICAL COAL SAMPLER CHECKLIST
(SECTION A – MECHANICAL SAMPLING & SECTION C – QUALITY MANAGEMENT)**

Company: _____ Date: _____
 Sampler Location and Identification: _____ Inspector: _____

I.	General Information			
	(a) Weather conditions			
	(b) Coal type (raw, clean, appearance, etc.)			
	(c) Coal top size			
	(d) Lot size			
	(e) Feed rate (maximum and normal)			
	(f) Purpose of sample			
	(g) Source of coal (rail car, barge, truck, stockpile)			
II.	Type of Sampling System	Falling-Stream Cross-Belt Auger	_____	Operators Recommended Inspection Frequency A Daily B Monthly C Each system operation
III.	Number of Stages		_____	
IV.	Start-up of Falling-Stream and Cross-Belt Systems			
	(a) System Checked, started prior to sampling		_____	C
	(b) Fluid level		_____	C
	(c) Oil temperature equilibrium		_____	C
V.	General Observations of Augers			
	(a) Human discretion in auger placement		_____	C
	(b) Auger placement patterns		_____	C
VI.	Primary Falling-Stream and Cross-Belt Cutters			
	(a) Size opening		_____	B
	(b) Cutting full stream		_____	C
	(c) Uniform speed		_____	B
	(d) Velocity		_____	B
	(e) Interval between cuts		_____	B
	(f) Contamination or loss of sample by leakage		_____	B
	(g) Parked out of coal stream		_____	B
	(h) Sample hopper enclosed		_____	B
	(i) Number of cuts per lot		_____	
VII.	Augers			
	(a) Consideration of top size		_____	C
	(b) Depth of extraction		_____	C
	(c) Number of increments		_____	A
VIII.	Primary Sample Feeder			
	(a) Type		_____	
	(b) Enclosed		Yes _____ No _____	B
	(c) Feedrate		_____	B
	(d) Belt wiper		Yes _____ No _____	B
IX.	Secondary Cutter			
	(a) Size opening		_____	B
	(b) Cutting full stream		_____	C
	(c) Uniform speed		_____	B
	(d) Velocity		_____	B
	(e) Interval between cuts		_____	B
	(f) Contamination or loss of sample by leakage		_____	B
	(g) Parked out of coal stream		_____	A
	(h) Sample hopper enclosed		_____	B
	(i) Number of cuts		_____	B
X.	Secondary Sample Feeder			
	(a) Type		_____	
	(b) Enclosed		Yes _____ No _____	B
	(c) Feedrate		_____	C
	(d) Belt wiper		Yes _____ No _____	A
XI.	Sample Crusher			
	(a) Coal product top size		_____	B
	(b) Equalizing pipe		Yes _____ No _____	B
XII.	Tertiary Cutter			
	(a) Size opening		_____	B
	(b) Cutting full stream		_____	C
	(c) Uniform speed		_____	B
	(d) Velocity		_____	B
	(e) Interval between cuts		_____	B
	(f) Contamination or loss of sample by leakage		_____	B
	(g) Parked out of coal stream		_____	A
	(h) Sample hopper enclosed		_____	A
	(i) Number of cuts		_____	B
XIII.	Final Sample			
	(a) Enclosed container		Yes _____ No _____	C

- (b) Length and size used for sample chute _____ B
- (c) Calculated mass of final sample from mechanical sampling system _____ B
- (d) Actual mass of sample _____ B
- (e) Ratio of actual sample mass (line XIII (d)) to lot size (line I (d)) _____ B

X2. MONITORING COAL SAMPLING RATIOS USING CONTROL CHARTS
(SECTION A – MECHANICAL SAMPLING & SECTION C – QUALITY MANAGEMENT)

X2.1 Scope

X2.1.1 This procedure may be used to monitor the consistency of coal sampling ratios obtained with common mechanical sampling system control settings of cutter operating intervals, cutter openings, cutter speeds (for falling-stream samplers), and belt speeds (for cross-belt samplers). Out-of-control conditions (see Section X2.4) or excessive variation (see Section X2.5) will serve to alert the operator to potential problems that need to be investigated.

X2.2 Rationale (Commentary)

X2.2.1 Pursuant to Part A, 9.11, the procedure offered in this Appendix is one means of continual monitoring of the consistency of the sampling ratio using methodology following the general principles of the *ASTM Manual on Presentation of Data and Control Chart Analysis*. An explanation of the value and use of control charts is given in *Out of the Crisis* (2).

X2.3 Data Collection and Charting Procedure

X2.3.1 For each lot sampled using a common sampling scheme, obtain and record the net mass of the sample collected at the final stage of mechanical sampling before any off-line sample preparation. Masses should be accurate to within 0.5 % of the mass recorded.

X2.3.2 Obtain and record the lot size (in Mg or tons) using belt scales or other similarly accurate device normally used for determining the lot size.

X2.3.3 Divide the sample mass by the lot size and express the result in pounds per 1000 kilograms or tons per 1000 metric tons.

X2.3.4 Calculate the average sampling ratio \bar{r} using Eq X2.1, where n is the number of sampling ratios in the chart and r_j is the i th sampling ratio in the series of ratios numbered 1 to n . The central line on the chart (CL) is equal to the average, \bar{r} .

$$\bar{r} = \frac{1}{n} \sum_{i=1}^n r_i \quad (X2.1)$$

X2.3.5 Calculate the average moving range \bar{R} using Eq X2.2, where Abs denotes the absolute value.

$$\bar{R} = \frac{1}{n-1} \sum_{i=2}^n \text{Abs}(r_i - r_{i-1}) \quad (X2.2)$$

X2.3.6 Calculate the lower control limit line (LCL) and upper control limit line (UCL) as,

$$\text{LCL} = \bar{r} - 2.66\bar{R} \quad (X2.3)$$

$$\text{UCL} = \bar{r} + 2.66\bar{R}$$

NOTE X2.1—The values of these limits are such that if there is a common system of chance causes of variation (no special cause is present) there is only about 1 chance in 100 that a sampling ratio value will be either below the value LCL or above the value UCL.

NOTE X2.2—The constant 2.66 is not a function of the number of n of sampling ratios being charted.

X2.3.7 Plot the sampling ratios on a line chart, with the vertical axis denoting sampling ratio values the horizontal axis denoting dates (and times, if appropriate). Sampling ratios values should always be plotted in chronological order. Add the central line (CL), the lower control limit line (LCL), and the upper control limit line (UCL) to the chart. See Fig. X2.1.

X2.4 Detection of Special Causes (Out-of-Control Conditions)

X2.4.1 A special cause of variation is indicated if one or more values are either above the upper control line or below the lower control line.

X2.4.2 A special cause of variation is indicated when there is a run defined by one of the following:

- (1) At least seven consecutive values are on one side of the central line.
- (2) At least ten out of eleven consecutive values are on one side of the central line.
- (3) At least twelve out of fourteen consecutive points on one side of the central line.

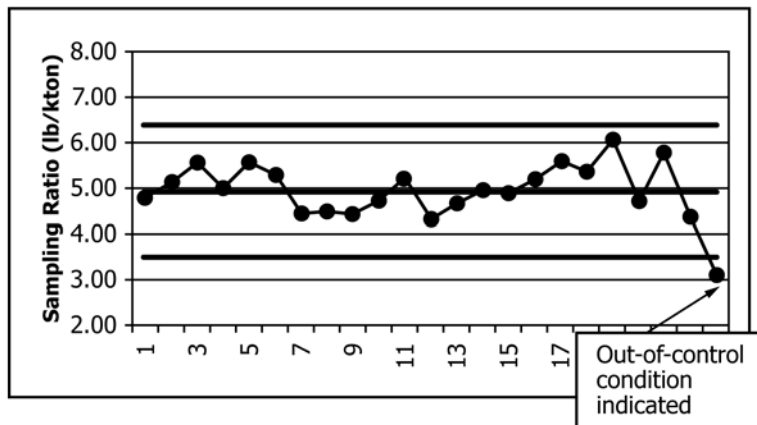

FIG. X2.1 Sampling Ratio Values

X2.4.3 A special cause of variation is indicated if there is a trend indicated by at least seven consecutive points increasing continually or at least seven consecutive points decreasing continually.

X2.4.4 If no out-of-control conditions are indicated, the sampling system is considered to be stable and in-control.

X2.5 Monitoring the Coefficient of Variation

X2.5.1 When there are 20 or more sampling ratios charted ($n \geq 20$) and the system is stable, calculate the percent coefficient of variation (%cv) using,

$$\%cv = \frac{s_r(100)}{\bar{r}} \quad (X2.4)$$

where s_r is the sample standard deviation of the sampling ratios obtained from

$$s_r = \left[\frac{1}{n-1} \sum_{i=1}^n (r_i - \bar{r})^2 \right]^{1/2} \quad (X2.5)$$

X2.5.2 A value for the %cv greater than 15 may indicate a need for system improvement. Among the items to be checked include the consistency of velocity of sampling system cutters; the cleanliness of oil and filters; hydraulic oil temperature variations; proper operation of all valves, cylinders, and pumps; the consistency of operation of timers; and the accuracy of the sample masses and lot sizes used in the calculations.

X2.6 Monitoring the Average Observed Sampling Ratio

X2.6.1 The division ratio d of either a falling-stream or a cross-belt sampler is calculated from the following equation:

$$d = \frac{w}{tv} \quad (X2.6)$$

where:

- w = the tip-to-tip cutter aperture width, in mm [in.],
- t = the activation interval, in seconds, and
- v = the velocity of the cutter (for falling-stream samplers) or velocity of the conveyor belt (for cross-belt samplers) in mm/s [in./s].

X2.6.2 The division ratio d_{sys} for a sampling system consisting of N sampling stages is calculated from the following equation:

$$d_{sys} = d_1 d_2 \dots d_N \quad (X2.7)$$

where:

- d_1 = the division ratio for the primary stage
- d_2 = the division ratio for the secondary stage, and
- d_N = the division ratio for the Nth stage

X2.6.3 The expected value of the observed sampling ratio is the design sampling ratio (alternatively known as the theoretical sampling ratio). The value r_D , in kg per thousand Mg [pounds per thousand tons] is calculated from the following equation:

$$r_D = d_{sys} K \quad (X2.8)$$

where:

$$K = 1,000,000 [2,000,000]$$

NOTE X2.3—The term design sampling ratio means the sampling ratio expected (by design), given the specific set of operating parameters (w , t , v) for each sampling stage. If one or more of these operating parameters is changed at any stage of sampling, the design sampling ratio changes.

NOTE X2.4—The constant value K in converts the division ratio from a fraction to units of kg/1000 Mg [lb/1000 ton].

Table X2.1 illustrates an example of such calculations.

X2.6.4 When there are twenty or more observed sampling ratios charted with no out-of-control condition indicated and the %cv calculated using is less than fifteen percent, compare the average observed ratio to the calculated design ratio. If the difference between the design ratio and the average observed ratio is greater than ten percent of the design ratio, an investigation of the cause is needed. One of the following may have occurred: (1) There is a significant error in one of the measured parameters w , t , or v for one or more stages of sampling. (2) There is a mechanical problem with the sampling system.

TABLE X2.1 Calculations of Systems Design Sampling Ratio

	w	t	v	d	r_D
Primary stage	6 in.	190 s	100 in./s	0.0003158	
Secondary stage	2 in.	21 s	14 in./s	0.0068027	
System				2.148E-06	4.30 kton/lb.

X3. MONITORING A MECHANICAL SAMPLING SYSTEM FOR BIAS (SECTION D – BIAS TESTING)

X3.1 Scope

X3.1.1 After an acceptable bias test is completed according to Part D, this procedure can be used to develop a program to monitor the ongoing performance of the mechanical sampling system for bias. It involves continuation of the collection of the bias test paired sets of sampling system save and reference samples on a periodic basis, such as over a time or tonnage interval. The qualities from system and reference samples are continually compared and the differences are examined for bias. The organization, planning, and system and reference increment collection must meet the minimum requirements of Practice D7430 Part D.

X3.2 Significance and Use

X3.2.1 It is intended that these procedures be used to provide additional evidence that the mechanical sampling system continues to provide unbiased samples after a bias test or between bias tests. Mechanical sampling systems are used extensively in industry for collecting samples while coal is being conveyed or transported in various stages of production, shipment, receipt, and use. The bias of the sampling system, in the measurement of coal quality, can have significant commercial and environmental consequences

X3.2.2 Data used to draw conclusions regarding bias are subject to sources of error other than those attributable to the biases in the sampling system. Biases introduced by handling, preparation, and analysis of samples can contribute to the appearance of bias in the sampling system; therefore, it is important to carefully follow the same system operating parameters, sample collection, and handling procedures used on the most recent acceptable bias test.

X3.2.3 In all cases, the test plan should reflect normal system operation and not be a source of bias itself.

X3.3 Apparatus

X3.3.1 *Sample Collection Devices:*

X3.3.1.1 *Stopped-Belt Divider Station*—A device similar to that illustrated in Fig. A1.1 and described in A1.1.3. The width between the divider plates must be the same throughout he divider, and no less than three times the nominal top size of the coal. Ensure that the width is sufficient, and the design of the mechanism adequate, to enable quick and easy removal of all coal lying on the conveyor belt between the divider plates, including very fine material.

X3.3.1.2 Consider installing a permanent sampling station(s) for collection of the reference stopped-belt samples. The permanent sampling station should include a permanent mounted stopped-belt divider which could easily be pivoted over and lowered on a stopped coal stream and a chute to facilitate the transfer of the reference sample into a sample container to prevent spillage and minimize down time. Permanent sampling station(s) provide an easy means for collecting stopped-belt samples and consistent location and equipment to

minimize opportunity to induce bias in results. This could be the same station that was used in the collection of bias test stopped-belt samples for Part D of this practice. See Fig. A1.1 in the Annex for examples of a stopped-belt station.

X3.3.2 *Sample Preparation Equipment*—Prepares all bias test samples using equipment specified in Practice D2013/D2013M.

X3.4 Description of Practice

X3.4.1 *Sample Collection:*

X3.4.1.1 After an acceptable bias test, pairs of system and reference samples are collected in the same manner as on the bias test except the collection frequency is now based on a pre-determined interval, such as over a time or tonnage interval. The quality from the system and reference samples are continually compared and the differences are plotted on a time series single rule control chart or appended into a database for repeating the statistical test used on the bias test. If using the chart, it is examined from one interval to the next for evidence of runs either above or below zero. If using the repeating statistical test, the appended data base is examined for bias. If either the control chart or statistical test indicates a problem, the sample preparation and sampling system are examined to determine the cause. The problem(s) should be corrected. In some instances, a change to the sampling operation may warrant conducting another Part D bias test.

X3.4.1.2 Any of the three basic test designs listed in Part D, Section 38 used for the bias test can be used for the continuous monitoring program. The important point is that the sample collection and handling methods always remain the same as the documented procedures used on the most recent acceptable bias test.

X3.4.1.3 Collect paired sets on a regular interval. Intervals such as weekly, monthly, tonnage basis, or another interval appropriate for the sampling operation are suggested as possibilities. The paired samples must be kept in chronological order when using them for the monitoring data.

X3.4.1.3.1 The shorter the interval between collecting paired sets, the quicker a potential problem can be detected.

X3.5 Procedures

X3.5.1 Determine a collection interval for paired test sets to be used in the monitoring program. Make the interval consistent from one paired test set to the next. The liabilities of not detecting a bias over an extended period should be considered when determining the interval. Collecting two paired test sets per month will cycle the complete dataset once a year and take about seven to eight months to detect bias should one develop. Collecting paired test sets weekly will cycle the complete dataset twice a year and lead to earlier detection of bias should one develop.

X3.5.1.1 If there is any chance of tying the test date and time with periodicities in quality, vary the time, day, or tonnage within the interval to reduce the risk of introducing a bias.

X3.5.2 Decide to use either a single rule control chart or a repeating statistical test (re-calculate one of the statistical tests outlined in Part D of this practice each time new data is appended to the data base) to monitor the sampling system after an acceptable bias test has been completed. Begin the program as soon as possible after the test.

X3.5.2.1 If using a single rule control chart, plot the differences between system and reference results from the most recent acceptable bias test. As new data sets are appended to the database from the continuous monitoring program, update the chart. Create a separate chart for each parameter determined on the bias test.

X3.5.2.2 If using the repeating statistical test method, establish the database using either data from the most recent acceptable bias test completed within the established collection interval for the monitoring program or begin collecting paired test sets to establish a new database. When using data from the most recent bias test, maintain the same number of paired test sets as was used on this test as data is appended to this database from the monitoring program. When collecting paired test sets under the monitoring program to establish a new database use the smallest number of paired test sets required to yield the desired confidence intervals, and then maintain this number of paired data sets throughout the monitoring program. It will normally require a minimum of ten paired data sets to calculate statistical inference.

X3.5.3 Start collection of paired sets in the monitoring program on the interval determined above and analyze for the parameters determined on the bias test. Keep all the data in chronological order. After new data is obtained from the monitoring program, append the new data to the database by adding the data from the newest paired set and deleting the data from the oldest paired set.

X3.5.3.1 *When Using the Single Rule Control Chart*—As new data is appended to the database, examine the control chart for evidence of bias.

NOTE X3.1—Upper and lower limits on a standard control chart are used to signify when a process is going out of control based on knowing the product variance; however, only detection of bias and consistency of trend is being monitored in this Appendix, hence a time series chart without upper and lower control limits (single rule control chart) is adequate for this application. Material variances alone could produce points beyond the control limits that would indicate out of control conditions when none exist.

(1) When the single rule control chart shows seven or more consecutive points either above or below zero, it is evidence bias may be developing. Using the current database, recalculate one of the statistical tests in Part D to confirm the bias. If a bias is not detected, continue on with the monitoring program. If there is evidence of bias, follow the steps in X3.5.4.

X3.5.3.2 *When Using the Repeating Statistical Test Method*—As new data is appended to the database, recalculate

the statistical method being used. If there is no evidence of bias, continue on with the monitoring program. If there is evidence of bias or the confidence intervals do not include zero, follow the steps in X3.5.4.

X3.5.4 *When there is Evidence of Bias:*

X3.5.4.1 Conduct an inspection of the sampler according to D7430 Part C. Also review the procedures used to collect, prepare and analyze the test samples. Determine if a change was made to the sampling system, sampling operation or the procedures for collecting, preparing or analyzing the test samples.

(1) If the cause of the bias cannot be detected, consider using the Interphase Test Design in Part D to help locate it.

X3.5.4.2 When the source of the bias is found, correct it, document it, and determine if a new bias test is required.

(1) If the bias is determined to be the result of changes to the sample collection, preparation, or analytical procedures, restore the original procedure(s) used on the bias test and proceed with the monitoring program. Retain the affected data in the database and on the control chart, if used. Note the data that was affected and the reason why, but do not use it in the statistical evaluations. Continue on with the monitoring program. Scrutinize new data to ensure the problem was corrected.

(2) If the bias is determined to be a result of change(s) to the sampling system or operation of it, determine if the system or operation can be restored to its original operation at the time of the most recent acceptable bias test. If the sampling system or operation can be restored to its original operation, restore it and examine the guidelines in Part D of this practice to determine if the system should be bias tested again.

(3) If a bias test is not required, retain the affected data in the database and on the control chart, if used. Note the data that was affected and the reason why, but do not use it in the statistical evaluations. Continue on with the monitoring program. Scrutinize new data to ensure the problem was corrected.

X3.5.5 *When a New Bias Test is Required:*

X3.5.5.1 If the sampling system or operation cannot be restored to original operation, bias test the sampling system again.

(1) If the results show the system is still biased, repeat the steps in X3.5.4 to locate it.

(2) When the results of the test are again acceptable, restart the monitoring system using the same sample, preparation and analytical procedures from it and start a new database.

X3.6 Additional Considerations for Development of the Program

X3.6.1 Review sections on organization and planning and the annexes associated with Practice D7430 Part D.

X3.7 Example of Single Rule Control Chart

X3.7.1 See Fig. X3.1.

sample division; sample reduction; sampling systems; split-spoon sampling; statistical analysis; stock pile sampling; truck sampling

X3.8 Keywords

X3.8.1 auger sampling; barge sampling; coal; coal sampling; inspection; mechanical sampling; railroad car sampling;

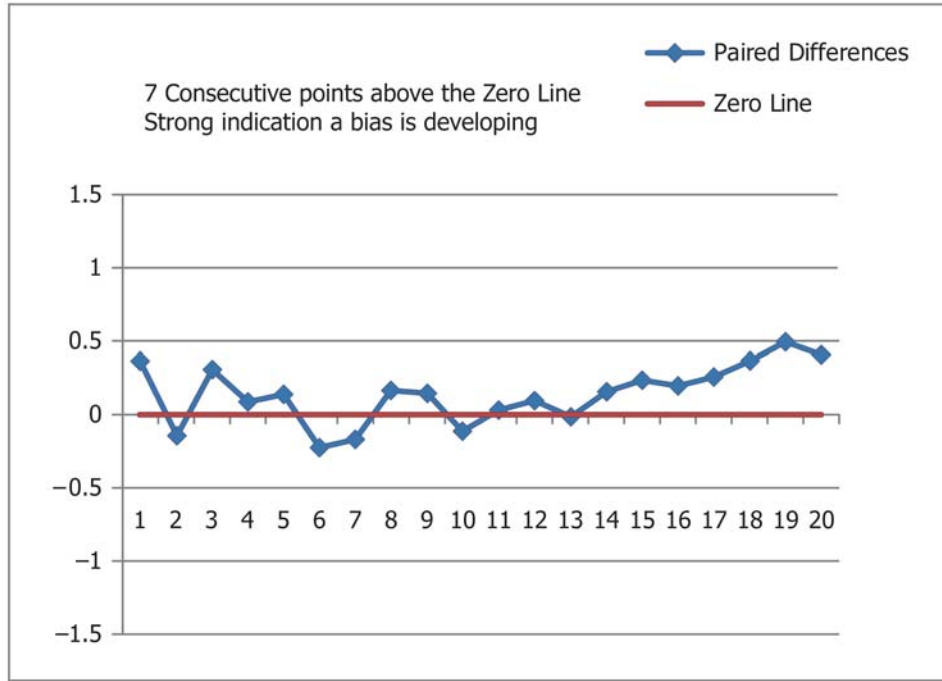

FIG. X3.1 Single Rule Control Chart

**X4. THEORETICAL CONSIDERATIONS AND SOURCES OF FORMULAS AND TABLES
(SECTION D – BIAS TESTING)**

X4.1 The Bonferroni inequality was used in preparing **Tables A2.5-A2.9** and **Table A2.11**. Let $\Theta = (\Theta_1, \Theta_2, \dots, \Theta_p)$ be a $(p \times 1)$ vector of parameters. Using the Bonferroni inequality, one may construct separate two-sided confidence intervals for each of p parameters, each with confidence coefficient $100(1 - \alpha/p)$. Then, if A_3 denotes the event that the interval for Θ_1 includes the actual value of Θ_1 , it follows that the probability that every interval covers the value of the parameter it estimates is at least $(1 - \alpha)$. Thus, the family confidence coefficient is at least $100(1 - \alpha) \%$ **(1)**. For **Tables A2.5-A2.9** and **Table A2.11**, the value 0.95, or 95 %, was chosen as a uniform value for the maximum two-sided family confidence coefficient.

X4.2 The test for independent differences, **A2.1.5**, Step 4, is the standard test for randomness based on the number of runs above and below the sample median **(3, 4)**. Values for the probability distribution of the total number of runs for samples of various sizes used to prepare **Tables A2.5-A2.9** were taken from Ref **(5)**.

X4.3 A nonparametric test based on an assumption of symmetry is used to draw conclusions about bias **(6)**. The reasons for using this type of test as opposed to a test based on normal theory are as follows:

X4.3.1 It is observed that while the results of some test data indicate the assumption of normally distributed paired differences may be a reasonable assumption, data from other tests

indicate a distribution heavier in the tails than normal **(7)**. In general, the data available from a specific test will be insufficient to exercise good judgment concerning the shape of the distribution at hand or for determining an appropriate normalizing transformation; thus, a test robust to departures from normality is preferred, and only symmetry is assumed. In the event the differences for a given test turn out to have a parent normal distribution, the loss through use of the more robust approach is small. In particular, the asymptotic relative efficiency of the nonparametric coverage for the center of symmetry compared to the coverage based on one- and two-sample t statistics is $3/\pi = 0.955$ for normally distributed populations. The asymptotic relative efficiency is generally greater than one for distributions whose tails are longer than those of a normally distributed population **(8)**.

X4.4 The procedure described in **A2.1.6**, Step 5, used to determine the joint confidence intervals, is the standard Tukey procedure based on the Wilcoxon Signed Rank Test **(9)**. In preparation of **Table A2.11**, for n equal to 15 or less, values of the probability distribution are taken from Table A5 of Ref **(9)**. For n greater than 15, the following approximation is used:

$$d = n(n+1)/4 - z_{\alpha/2}[n(n+1)(2n+1)/24]^{1/2} \quad (\text{X4.1})$$

where:

$z_{\alpha/2}$ = point on a standard normal with probability $\alpha/2$ above it.

REFERENCES

- (1) Alt, F. B., “Bonferroni Inequalities and Intervals,” in *Encyclopedia of Statistical Sciences*, Vol 1, Wiley, New York, 1982, pp. 294–300.
- (2) Deming, W. E., *Out of the Crisis*, MIT Center for Advanced Engineering Studies, 1986, pp. 309–370.
- (3) Walsh, J. E., *Handbook of Nonparametric Statistics*, D. Van Nostrand, Princeton, NJ, 1962, p. 64.
- (4) Johnson, N. L., and Leone, F. C., *Statistics and Experimental Design*, Vol 1, 2nd Ed., Wiley, New York, 1977, Chapter 9.
- (5) Beyer, W. H., Ed., *CRC Handbook of Tables for Probability and Statistics*, 2nd Ed., CRC Press, Boca Raton, FL, 1968, Table X6.
- (6) Randles, R. H., “Tukey’s Confidence Interval for Location,” in *Encyclopedia of Statistical Sciences*, Vol 9, Wiley, New York, 1988, pp. 359–361.
- (7) Rose, C. D., “A New Approach to Bias Testing of Mechanical Coal Sampling Systems,” *The Journal of Coal Quality*, Vol 9, No. 4, Oct.–Dec. 1990, pp. 124–129.
- (8) Noether, G. E., “Nonparametric Confidence Intervals,” in *Encyclopedia of Statistical Sciences*, Vol 6, Wiley, New York, 1985, pp. 319–324.
- (9) Hollander, M., and Wolfe, D. A., *Nonparametric Statistical Methods*, Wiley, New York, 1973, pp. 35–38, and Table A3.

ASTM International takes no position respecting the validity of any patent rights asserted in connection with any item mentioned in this standard. Users of this standard are expressly advised that determination of the validity of any such patent rights, and the risk of infringement of such rights, are entirely their own responsibility.

This standard is subject to revision at any time by the responsible technical committee and must be reviewed every five years and if not revised, either reapproved or withdrawn. Your comments are invited either for revision of this standard or for additional standards and should be addressed to ASTM International Headquarters. Your comments will receive careful consideration at a meeting of the responsible technical committee, which you may attend. If you feel that your comments have not received a fair hearing you should make your views known to the ASTM Committee on Standards, at the address shown below.

This standard is copyrighted by ASTM International, 100 Barr Harbor Drive, PO Box C700, West Conshohocken, PA 19428-2959, United States. Individual reprints (single or multiple copies) of this standard may be obtained by contacting ASTM at the above address or at 610-832-9585 (phone), 610-832-9555 (fax), or service@astm.org (e-mail); or through the ASTM website (www.astm.org). Permission rights to photocopy the standard may also be secured from the Copyright Clearance Center, 222 Rosewood Drive, Danvers, MA 01923, Tel: (978) 646-2600; <http://www.copyright.com/>