



Designation: D7378 – 16

Standard Practice for Measurement of Thickness of Applied Coating Powders to Predict Cured Thickness¹

This standard is issued under the fixed designation D7378; the number immediately following the designation indicates the year of original adoption or, in the case of revision, the year of last revision. A number in parentheses indicates the year of last reapproval. A superscript epsilon (ϵ) indicates an editorial change since the last revision or reapproval.

1. Scope

1.1 This practice describes the thickness measurement of dry coating powders applied to a variety of rigid substrates. Use of some of these procedures may require repair of the coating powder. This practice covers the use of portable instruments. It is intended to supplement the manufacturers' instructions for their operation of the gages and is not intended to replace them. It includes definitions of key terms, reference documents, the significance and use of the practice, and the advantages and limitations of the instruments.

1.2 Three procedures are provided for measuring dry coating powder thickness:

1.2.1 *Procedure A*—Using rigid metal notched (comb) gages.

1.2.2 *Procedure B*—Using magnetic or eddy current coating thickness gages.

1.2.3 *Procedure C*—Using non-contact ultrasonic powder thickness instruments.

1.3 Coating powders generally diminish in thickness during the curing process. Some of these procedures therefore require a reduction factor be established to predict cured film thickness of powder coatings.

1.4 *Procedure A and Procedure B* measure the thickness (height or depth) of the applied coating powders in the pre-cured, pre-gelled state. By comparing results to the measured cured powder thickness in the same location, a reduction factor can be determined and applied to future thickness measurements of the same coating powder.

1.5 *Procedure C* results in a predicted thickness value of the cured state based on a calibration for typical coating powders. If the powder in question is not typical then an adjustment can be made to align gage readings with the actual cured values as determined by other measurement methods.

¹ This practice is under the jurisdiction of ASTM Committee D01 on Paint and Related Coatings, Materials, and Applications and is the direct responsibility of Subcommittee D01.51 on Powder Coatings.

Current edition approved Dec. 1, 2016. Published March 2017. Originally approved in 2007. Last previous edition approved in 2010 as D7378 – 10. DOI: 10.1520/D7378-16.

1.6 The values stated in SI units are to be regarded as the standard. The values given in parentheses are for information only.

1.7 *This standard does not purport to address all of the safety concerns, if any, associated with its use. It is the responsibility of the user of this standard to establish appropriate safety and health practices and determine the applicability of regulatory limitations prior to use.*

2. Referenced Documents

2.1 *ASTM Standards*:²

D4138 Practices for Measurement of Dry Film Thickness of Protective Coating Systems by Destructive, Cross-Sectioning Means

D6132 Test Method for Nondestructive Measurement of Dry Film Thickness of Applied Organic Coatings Using an Ultrasonic Coating Thickness Gage

D7091 Practice for Nondestructive Measurement of Dry Film Thickness of Nonmagnetic Coatings Applied to Ferrous Metals and Nonmagnetic, Nonconductive Coatings Applied to Non-Ferrous Metals

3. Terminology

3.1 *Definitions of Terms Specific to This Standard*:

3.1.1 *accuracy, n*—the measure of the magnitude of error between the result of a measurement and the true thickness of the item being measured.

3.1.2 *adjustment, n*—the physical act of aligning a gage's thickness readings to match those of a known thickness sample (reduction of bias) in order to improve the accuracy of the gage on a specific surface, within a specific portion of its measurement range or to specific operating conditions.

3.1.2.1 *Discussion*—An adjustment will affect the outcome of subsequent readings.

3.1.3 *coating powders, n*—finely divided particles of resin, either thermoplastic or thermosetting, generally incorporating pigments, fillers, and additives and remaining finely divided

² For referenced ASTM standards, visit the ASTM website, www.astm.org, or contact ASTM Customer Service at service@astm.org. For *Annual Book of ASTM Standards* volume information, refer to the standard's Document Summary page on the ASTM website.

during storage under suitable conditions, which, after fusing and possibly curing, give a continuous film.

3.1.4 *calibration, n*—the high-level, controlled and documented process of obtaining measurements on traceable calibration standards over the full operating range of the gage, then making the necessary gage adjustments (as required) to correct any out-of-tolerance conditions.

3.1.4.1 *Discussion*—Calibration of coating thickness gages is performed in a controlled environment using a documented process by the equipment manufacturer, their authorized agent, or by an accredited calibration laboratory. The outcome of the calibration process is to restore/realign the gage to meet/exceed the manufacturer’s stated accuracy and may result in the creation of a calibration certificate recording the results of the process at the time of testing.

3.1.5 *powder coatings, n*—coatings which are protective or decorative, or both, formed by the application of a coating powder to a substrate and fused in a continuous film by the application of heat or radiant energy.

3.1.6 *dry film thickness, n*—the thickness of a cured coating (or coating layers) as measured from the surface of the substrate.

3.1.7 *micrometer (micron), n*—one one-thousandth of a millimeter (0.001 mm); 25.4 microns = 1 mil.

3.1.8 *mil, n*—an imperial unit of measure; one one-thousandth of an inch (0.001 in.); 1 mil = 25.4 microns.

3.1.9 *substrate, n*—the base material, type of surface or component that is being coated.

3.1.10 *uncured, adj*—the physical state of coating powder when particles are electrostatically held to a substrate.

3.1.11 *verification of accuracy, n*—comparing predicted thickness values with actual cured thickness values and ensuring both are within their combined measurement tolerances.

4. Summary of Practice

4.1 The three procedures take measurements of applied coating powders in the pre-cured, pre-gelled state. Each procedure employs different devices to measure the dry powder.

4.2 *Procedure A*—Uses a metal notched gage to manually determine the thickness of the coating powder. The gage is dragged through the powder a short distance. Powder thickness is determined as being between the highest numbered tooth that made a mark and has powder clinging to it, and the next highest tooth that left no mark and has no powder clinging to it. Measurements can be made on a suitable rigid surface, metal or non-metal but marks will be made in the powder that may not be covered when the powder flows in the cure process.

4.3 *Procedure B*—Uses a conventional magnetic or eddy current coating thickness gage with a specially designed powder probe to measure the thickness of the coating powder. Micro pins, which are integrated into the probe, penetrate the coating powder down to the substrate. The probe is manually pressed down to the surface of the powder to effect a thickness measurement. This procedure is applicable to flat, metal substrates only. Marks may be made in the powder that may not be covered when the powder flows in the cure process.

4.4 *Procedure C*—Uses a non-contact ultrasonic powder thickness instrument to take a measurement of the applied coating powder to calculate and display a predicted cured thickness. Measurements can be made on any rigid surface.

4.5 The thickness of dry coating powder diminishes during the curing process. To predict the cured powder coating thickness, a correlation must be made between pre-cured and post-cured thicknesses.

4.5.1 *Procedure A and Procedure B* result in a thickness measurement of the uncured coating powder only. A reduction factor must then be used to predict the cured powder thickness for each particular coating powder. This reduction factor is

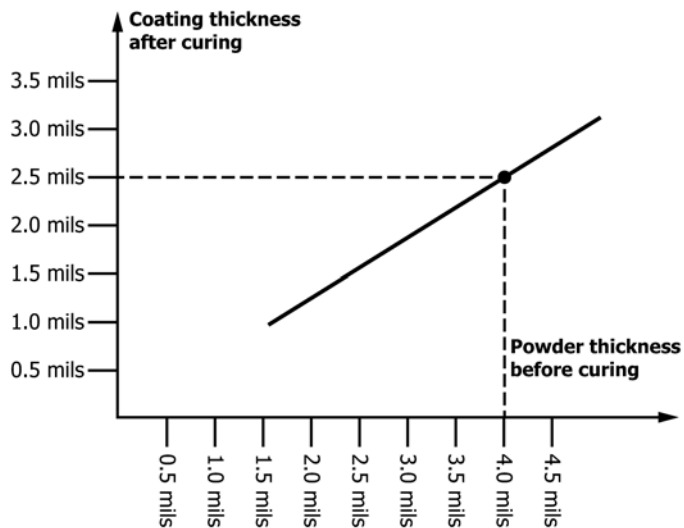

FIG. 1 Typical Correlation Between Pre- and Post-cured Powder

obtained by measuring the cured powder thickness at the same location where the uncured powder thickness measurement was taken. For best accuracy, measurements before and after curing should be taken for different thicknesses. A sample plot of measurement results is shown in Fig. 1. From this plot a reduction factor can be determined and applied to all future dry coating powder thickness measurements to predict cured thickness. As coating powder properties may alter over time, this value should be confirmed annually or when there is a change in powder suppliers.

4.5.2 *Procedure C* does not provide a dry powder thickness measurement. The user can make an adjustment to the instrument by measuring the cured powder thickness at the same location where the uncured powder thickness measurement was taken and align the gage readings with the cured coating readings.

5. Significance and Use

5.1 Many physical and appearance properties of the finished coating are affected by the film thickness. Film thickness can affect the color, gloss, surface profile, adhesion, flexibility, impact resistance and hardness of the coating. The fit of pieces assembled after coating can be affected when film thickness is not within tolerance. Therefore coatings must be applied within certain minimum and maximum film thickness specifications to optimize their intended use.

5.2 All procedures involve taking measurements of applied coating powders in the pre-cured, pre-gelled state to help insure correct cured film thickness. This enables the application system to be set up and fine-tuned prior to the curing process. In turn, this will reduce the amount of scrap and over-spray. Accurate predictions help avoid stripping and re-coating which can cause problems with adhesion and coating integrity.

5.3 Measurements of cured powder coating thickness can be made using different methods depending upon the substrate. Non-destructive measurements over metal substrates can be made with magnetic and eddy current coating thickness gages (see Practice D7091). Non-destructive measurements over non-metal substrates can be made with ultrasonic coating thickness gages (see Test Method D6132). Destructive measurements over rigid substrates can be made with cross-sectioning instruments (see Practices D4138).

6. Test Specimen

6.1 The test specimen can be the coated part on which the powder thickness is to be evaluated, or can be test panels of similar material and shape on which it is desired to measure the coating thickness.

PROCEDURE A—METAL NOTCHED GAGES

7. Apparatus

7.1 *Metal Notched Gage* with at least one end (edge) consisting of a series of teeth extending from the body and spaced from each other. The teeth are of different length. Two legs or stand-offs extend beyond the teeth at both ends of the row of teeth to support the gage against the coated substrate

(see Fig. 2). Several models are available to measure a broad range of coating powder thicknesses.

NOTE 1—Notched gages intended for measuring wet film thickness are generally not suitable for measuring powder thickness. They usually have square teeth with increments too fine for powder measurement.

8. Procedure

8.1 Select a test panel or choose a site for the thickness measurement.

8.2 Select a gage model with a scale range of teeth height covering the range of estimated powder thickness. If thickness is unknown, make a trial determination with a model that covers the range of approximately 50 to 300 microns (2 to 12 mils).

8.3 Push the gage perpendicularly into the dry coating powder so that the two stand-offs (end tabs) on both sides of the teeth rest firmly on the substrate.

8.4 Keeping the gage perpendicular to the surface, drag the gage along the surface of the coated part for at least 1 cm (0.5 in.) thereby generating lines in the powder where the teeth touch it.

8.5 Remove the gage from the surface and examine the marks left in the powder. The powder thickness is considered to be a range value between the highest numbered tooth that made a mark and has powder clinging to it, and the next highest tooth that left no mark and has no powder clinging to it.

8.6 Using the reduction factor obtained from a previously prepared correlation chart for that particular coating powder (see Fig. 1), convert the measured powder thickness value to a predicted cured thickness value.

PROCEDURE B—MAGNETIC OR EDDY CURRENT COATING THICKNESS GAGES

9. Apparatus

9.1 *Coating Thickness Gage Body*—An electronic device (host unit) that accepts a probe to effect a thickness measurement.

9.2 *Powder Probe*—A measuring probe connected to the coating thickness gage body consisting of integrated micro

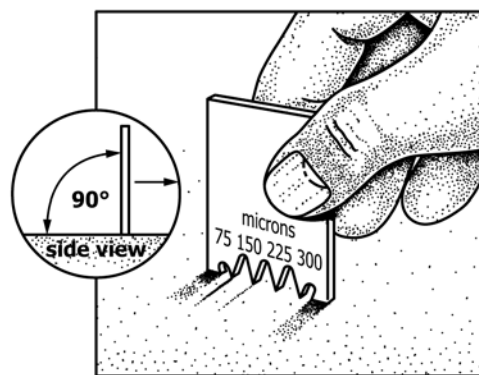

FIG. 2 A Metal Notched Gage

pins, a deflection foil and operating on a magnetic or eddy current principle (see Fig. 3).

10. Procedure

10.1 Select a test panel or choose a site for thickness measurement.

10.2 Connect the probe to the coating thickness gage body.

10.3 Verify gage accuracy on shims of known thickness and adjust if necessary according to the manufacturer's instructions.

10.4 Place the probe onto the applied dry powder until the micro pins contact the substrate. Press down on the probe until the integrated deflection foil makes minor contact with the powder.

10.5 Record the thickness (powder height) value displayed on the coating thickness gage.

10.6 Using the reduction factor obtained from a previously prepared correlation chart for that particular coating powder (see Fig. 1), convert the measured powder thickness value to a predicted cured thickness value.

PROCEDURE C—NON-CONTACT ULTRASONIC POWDER THICKNESS INSTRUMENTS

11. Apparatus

11.1 *Non-Contact Ultrasonic Powder Thickness Instrument*—See Fig. 4.

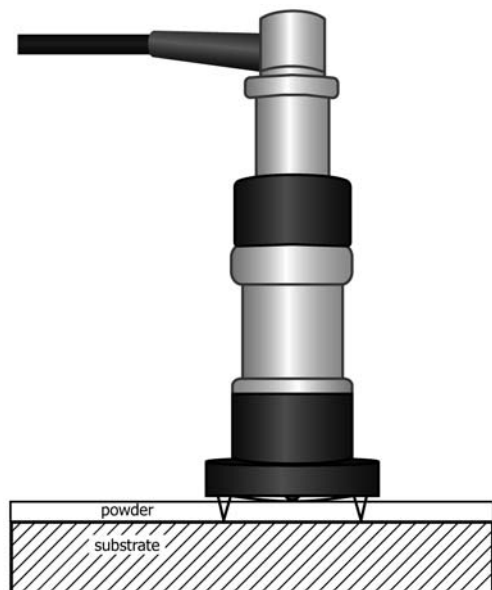

FIG. 3 A Powder Probe



FIG. 4 A Non-contact Ultrasonic Powder Thickness Instrument

12. Procedure

12.1 Select a test panel or choose a site for thickness measurement.

12.2 Zero the probe of the instrument according to the manufacturer's instructions.

12.3 Position the probe of the instrument close to the applied coating powder and take measurements following the manufacturer's instructions.

13. Report

13.1 The following items should be reported:

13.1.1 Gage type (manufacturer, model and serial number if available),

13.1.2 Measurement range of the instrument,

13.1.3 Method of accuracy verification and adjustment (if appropriate),

13.1.4 Reduction factor calculations (Procedures A and B),

13.1.5 Size and description of the test specimen,

13.1.6 Results of a thickness determination,

13.1.7 If more than one measurement is made and specific results for each location are not needed, report the minimum, the maximum, and the average thickness, and

13.1.8 Gage operator's name, and

13.1.9 Date of the inspection.

14. Keywords

14.1 coating powder; coating thickness; film thickness; powder coating; powder thickness; thickness prediction; ultrasonic

ASTM International takes no position respecting the validity of any patent rights asserted in connection with any item mentioned in this standard. Users of this standard are expressly advised that determination of the validity of any such patent rights, and the risk of infringement of such rights, are entirely their own responsibility.

This standard is subject to revision at any time by the responsible technical committee and must be reviewed every five years and if not revised, either reapproved or withdrawn. Your comments are invited either for revision of this standard or for additional standards and should be addressed to ASTM International Headquarters. Your comments will receive careful consideration at a meeting of the responsible technical committee, which you may attend. If you feel that your comments have not received a fair hearing you should make your views known to the ASTM Committee on Standards, at the address shown below.

This standard is copyrighted by ASTM International, 100 Barr Harbor Drive, PO Box C700, West Conshohocken, PA 19428-2959, United States. Individual reprints (single or multiple copies) of this standard may be obtained by contacting ASTM at the above address or at 610-832-9585 (phone), 610-832-9555 (fax), or service@astm.org (e-mail); or through the ASTM website (www.astm.org). Permission rights to photocopy the standard may also be secured from the Copyright Clearance Center, 222 Rosewood Drive, Danvers, MA 01923, Tel: (978) 646-2600; <http://www.copyright.com/>