



# Standard Test Method for Determining Water Migration Resistance Through Roof Membranes<sup>1</sup>

This standard is issued under the fixed designation D7281; the number immediately following the designation indicates the year of original adoption or, in the case of revision, the year of last revision. A number in parentheses indicates the year of last reapproval. A superscript epsilon ( $\epsilon$ ) indicates an editorial change since the last revision or reapproval.

## 1. Scope

1.1 This test method covers the determination of water migration resistance of roof membranes including built-up roof membranes, modified bitumen, and single ply roof membranes. The procedures were developed to determine the potential for leakage of water through the roof membranes resulting from a standing head of water and when pressurized with air from the underside.

1.2 The values stated in SI units are to be regarded as the standard. The values given in parentheses are for information only.

1.3 *This standard does not purport to address all of the safety concerns, if any, associated with its use. It is the responsibility of the user of this standard to establish appropriate safety and health practices and determine the applicability of regulatory limitations prior to use.*

## 2. Referenced Documents

2.1 *ASTM Standards:*<sup>2</sup>

**G154 Practice for Operating Fluorescent Ultraviolet (UV) Lamp Apparatus for Exposure of Nonmetallic Materials**

## 3. Terminology

3.1 *Definitions:*

3.1.1 *adhere*—to cause two surfaces to be held together by adhesion. Roof membranes are often “partially-” or “totally-adhered” to a substrate.

3.1.2 *batten*—a narrow band or plate that is used to fasten or prevent the displacement of a single ply membrane.

3.1.3 *delamination*—separation between lamination or bonded material or component; for example, laminated layers of rigid insulation or the felt plies in a built-up roof.

<sup>1</sup> This test method is under the jurisdiction of ASTM Committee D08 on Roofing and Waterproofing and is the direct responsibility of Subcommittee D08.20 on Roofing Membrane Systems.

Current edition approved May 1, 2013. Published May 2013. Originally approved in 2007. Last previous edition approved in 2007 as D7281 – 07. DOI: 10.1520/D7281-07R13.

<sup>2</sup> For referenced ASTM standards, visit the ASTM website, [www.astm.org](http://www.astm.org), or contact ASTM Customer Service at [service@astm.org](mailto:service@astm.org). For *Annual Book of ASTM Standards* volume information, refer to the standard's Document Summary page on the ASTM website.

3.1.4 *field seam*—a splice made in the field of a single ply membrane that joins two sheets together using an adhesive, splicing tape, heat, or solvent-welding.

3.1.5 *mechanically fastened membranes*—a single ply or base ply (part of a multi-layer system) membrane that has been positively attached at intervals to the substrate, usually with fasteners and/or other mechanical devices, such as battens.

3.1.6 *NPT*—National Pipe Thread.

## 4. Summary of Test Method

4.1 Roofing membranes are conditioned and installed in the leakage test apparatus (Fig. 1). A 152-mm (6-in.) head of water is maintained over the sample for 7 days at ambient conditions, 21°C (70°F). At the end of the 7 day period, air shall be introduced into the bottom section of the apparatus, increasing the pressure to 6.9 kPa (1 psig) and immediately released to ambient conditions. This cycle is repeated 25 times.

## 5. Significance and Use

5.1 This test method provides a means of evaluating roof membranes, seams, and laps for resistance to water migration from standing water on the roof. This test method evaluates roof membranes when first applied and also after simulated deterioration caused by the ultraviolet energy of the sun.

## 6. Apparatus

6.1 The test apparatus consists of top section, a support plate, and a bottom section, which are clamped together with the sample being evaluated placed as a diaphragm between the top sections and the support plate.

6.1.1 The top section consists of a 203-mm (8-in.) diameter, 6-mm (1/4-in.) wall thickness × 203-mm (8-in.) length of clear acrylic pipe, which is cemented to a 305-mm (12-in.) diameter flange.

6.1.2 The support plate is a round poly(vinyl chloride) plate, 6-mm (1/4-in.) thick and a 241-mm (9½-in.) diameter with 6-mm (1/4-in.) diameter holes spaced 25 mm (1 in.) on center.

6.1.3 The bottom section consists of a 305-mm (12-in.) diameter flange attached to a 203-mm (8-in.) diameter, 6-mm (1/4-in.) wall thickness × 152-mm (6-in.) length of clear acrylic pipe, which is fabricated with two threaded holes 6 mm (1/4 in.) NPT. These holes are used after the test apparatus sections are

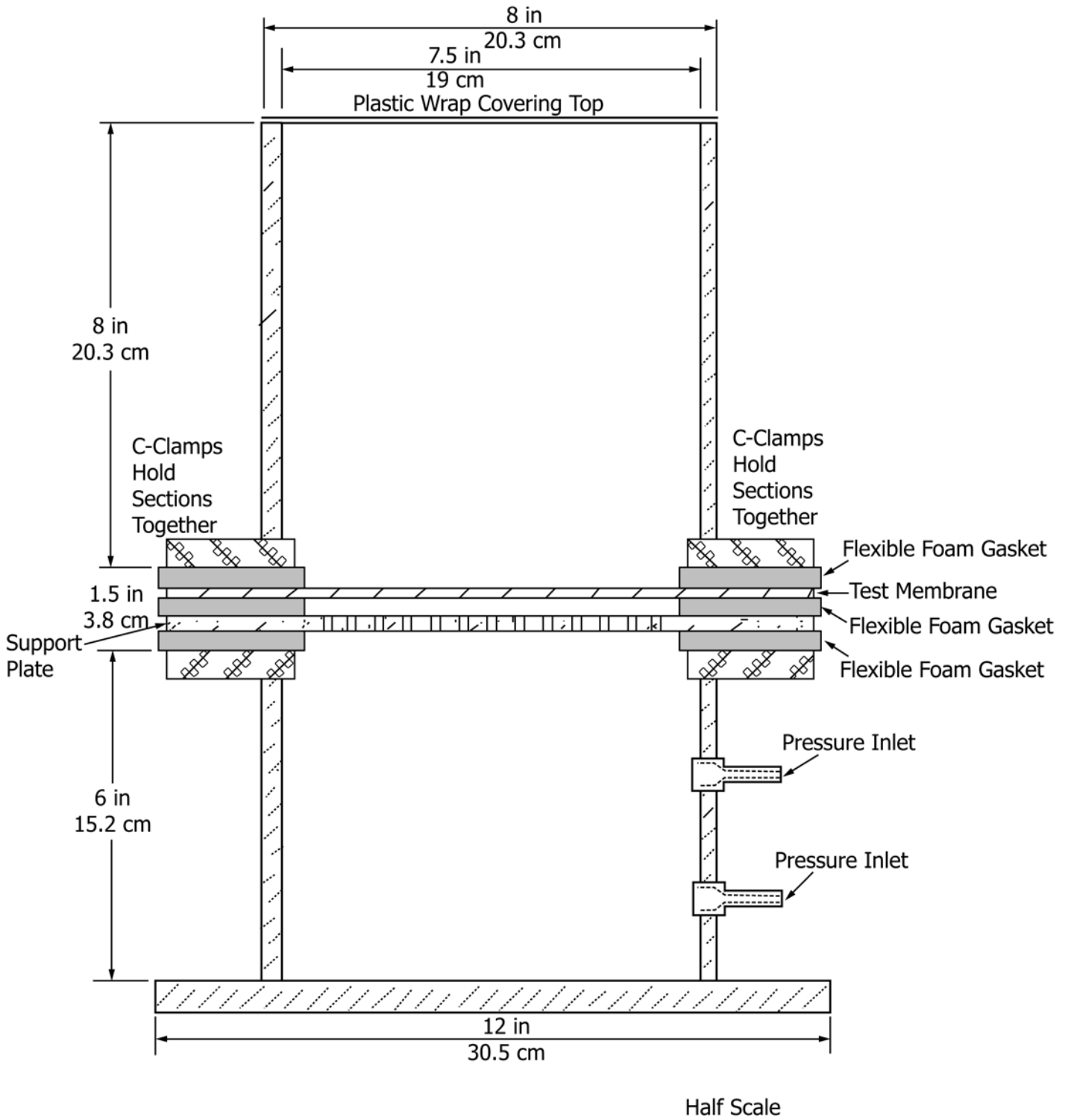

FIG. 1 Leakage Test Apparatus

clamped together, with the roof cover between them. One hole provides a connection point for air pressure to be increased and released; the other hole provides a connection for the pressure gauge. A 305-mm (12-in.) diameter bottom cap is adhered to the bottom section.

6.1.4 The gasket material consists of a non-absorbent, flexible closed cell foam. A silicone sealant is permitted to be used to further aid in preventing water from leaking around the perimeter of the flange of the test apparatus.

## 7. Sampling, Test Specimens, and Test Units

7.1 A roof membrane  $0.6 \times 1.2$  m ( $2 \times 4$  ft) is selected from the material to be tested. A standard field seam, if present, is incorporated per the manufacturer's instructions, in the center of the sample in the 1.2 m (4 ft) direction.

7.2 After a preparation and conditioning (laboratory cure), if required, the roof membrane is cut to produce two  $305 \times 610$  mm ( $12 \times 24$  in.) samples with a standard field joint in the 305 mm (12 in.) direction.

## 8. Conditioning

8.1 A  $305 \times 610$  mm ( $12 \times 24$  in.) roof membrane sample with a standard field joint is conditioned (laboratory cure) at ambient conditions for up to 28 days.

8.2 A piece of roof membrane  $305 \times 610$  mm ( $12 \times 24$  in.) with a standard field joint is conditioned (weathered) for 1000 h in a fluorescent ultraviolet condensation-type weather apparatus conforming to Practice **G154**. The sample will be exposed to UV radiation using a UVA 340 lamp. Exposure to moisture shall be by condensation method. The cycle times shall be set for 8 h of UV and 8 h of condensation. The light temperature shall be set at  $63 \pm 3^\circ\text{C}$  ( $145 \pm 5^\circ\text{F}$ ) and the condensation temperature shall be set at  $50 \pm 3^\circ\text{C}$  ( $122 \pm 5^\circ\text{F}$ ). Upon removal from the weather apparatus, the sample is again inspected for damage.

## 9. Procedure

9.1 Two 254-mm (10-in.) diameter samples are then cut from conditioned specimens (see Section 8) and clamped in place between the flanges of the test apparatus or between the upper section and the support plate if required. A 152 mm (6 in.) head of water is maintained over the specimen for 7 days at ambient conditions,  $21^\circ\text{C}$  ( $70^\circ\text{F}$ ). If a standard field seam is present, it shall be included in the specimen. At the end of the 7 day period, air is introduced into the bottom section of the

apparatus, increasing the pressure to 6.9 kPa (1 psig) and immediately released to ambient conditions. This cycle is repeated 25 times. The sample is then inspected for damage and leakage.

## 10. Interpretation of Results

10.1 There shall be no sign of water leakage during the 7 day test period.

## 11. Report

11.1 Report the following information:

11.1.1 Materials used in sample construction.

11.1.2 Date and specifics of sample construction.

11.1.3 Date and time that sample was placed in the weathering apparatus.

11.1.4 Date and time that sample was removed from the weathering apparatus.

11.1.5 Date and time sample placed in leakage test apparatus.

11.1.6 Date and time of air pressure cycles.

11.1.7 Determination of pass/fail of sample.

11.1.8 If any water is or is not present on the underside of the membrane.

11.1.9 Any notable comments.

## 12. Precision and Bias

12.1 The test result is determined by the visual pass/fail (go/no go) observation.

12.2 No information is presented about either the precision or bias of this test method for measuring water migration resistance since the test result is non-quantitative.

## 13. Keywords

13.1 condensation; laminated; roof membrane; ultraviolet radiation; water leakage; weathering

*ASTM International takes no position respecting the validity of any patent rights asserted in connection with any item mentioned in this standard. Users of this standard are expressly advised that determination of the validity of any such patent rights, and the risk of infringement of such rights, are entirely their own responsibility.*

*This standard is subject to revision at any time by the responsible technical committee and must be reviewed every five years and if not revised, either reapproved or withdrawn. Your comments are invited either for revision of this standard or for additional standards and should be addressed to ASTM International Headquarters. Your comments will receive careful consideration at a meeting of the responsible technical committee, which you may attend. If you feel that your comments have not received a fair hearing you should make your views known to the ASTM Committee on Standards, at the address shown below.*

*This standard is copyrighted by ASTM International, 100 Barr Harbor Drive, PO Box C700, West Conshohocken, PA 19428-2959, United States. Individual reprints (single or multiple copies) of this standard may be obtained by contacting ASTM at the above address or at 610-832-9585 (phone), 610-832-9555 (fax), or service@astm.org (e-mail); or through the ASTM website (www.astm.org). Permission rights to photocopy the standard may also be secured from the Copyright Clearance Center, 222 Rosewood Drive, Danvers, MA 01923, Tel: (978) 646-2600; http://www.copyright.com/*