



Standard Test Method for Freezing Point of Aviation Fuels (Automatic Fiber Optical Method)¹

This standard is issued under the fixed designation D7154; the number immediately following the designation indicates the year of original adoption or, in the case of revision, the year of last revision. A number in parentheses indicates the year of last reapproval. A superscript epsilon (ϵ) indicates an editorial change since the last revision or reapproval.

INTRODUCTION

This test method is nearly identical to Test Method **D5901**. The difference in this test method is the version of software (version V.22) that is utilized in the apparatus. This version of software is intended to better identify samples that are contaminated. Since the algorithm in this version of software is different than previous versions utilized in this apparatus, the subcommittee determined to publish a separate test method with a different standard designation.

1. Scope*

1.1 This test method covers the determination of the temperature below which solid hydrocarbon crystals may form in aviation turbine fuels.

NOTE 1—This test method describes an alternative procedure and automatic apparatus which closely mimics the apparatus and procedure described in Test Method **D2386**.

1.2 The measuring range of the apparatus is from $-70\text{ }^{\circ}\text{C}$ to $0\text{ }^{\circ}\text{C}$, however the precision statements were derived only from samples with freezing point temperatures from $-60\text{ }^{\circ}\text{C}$ to $-42\text{ }^{\circ}\text{C}$.

NOTE 2—Typical aviation fuel has freezing point temperatures in the $-60\text{ }^{\circ}\text{C}$ to $-40\text{ }^{\circ}\text{C}$ range.

1.3 Some results from this test method (14 % of samples included in the 2003 round robin²) incorrectly identified sample contamination where no contaminants were present in the samples (see research report² for further information).

1.4 The values stated in SI units are to be regarded as standard. No other units of measurement are included in this standard.

1.5 *This standard does not purport to address all of the safety concerns, if any, associated with its use. It is the*

responsibility of the user of this standard to establish appropriate safety and health practices and determine the applicability of regulatory limitations prior to use. For specific hazard statements, see Section 7.

2. Referenced Documents

2.1 *ASTM Standards:*³

D2386 Test Method for Freezing Point of Aviation Fuels
D4057 Practice for Manual Sampling of Petroleum and Petroleum Products

D4177 Practice for Automatic Sampling of Petroleum and Petroleum Products

D5901 Test Method for Freezing Point of Aviation Fuels (Automated Optical Method) (Withdrawn 2010)⁴

D6708 Practice for Statistical Assessment and Improvement of Expected Agreement Between Two Test Methods that Purport to Measure the Same Property of a Material

E1 Specification for ASTM Liquid-in-Glass Thermometers

2.2 *Energy Institute Standard:*

IP 16 Determination Freezing Point of Aviation Fuels

3. Terminology

3.1 *Definitions:*

3.1.1 *freezing point, n—in aviation fuels*, the fuel temperature at which solid hydrocarbon crystals, formed on cooling,

¹ This test method is under the jurisdiction of ASTM Committee **D02** on Petroleum Products, Liquid Fuels, and Lubricants and is the direct responsibility of Subcommittee **D02.07** on Flow Properties.

Current edition approved April 1, 2015. Published April 2015. Originally approved in 2005. Last previous edition approved in 2010 as D7154 – 05 (2010). DOI: 10.1520/D7154-15.

² Supporting data (2003 Interlaboratory Cooperative Test Program) have been filed at ASTM International Headquarters and may be obtained by requesting Research Report RR:D02-1572.

³ For referenced ASTM standards, visit the ASTM website, www.astm.org, or contact ASTM Customer Service at service@astm.org. For *Annual Book of ASTM Standards* volume information, refer to the standard's Document Summary page on the ASTM website.

⁴ The last approved version of this historical standard is referenced on www.astm.org.

*A Summary of Changes section appears at the end of this standard

disappear when the temperature of the fuel is allowed to rise under specified conditions of test.

3.2 Definitions of Terms Specific to This Standard:

3.2.1 *automatic fiber optical method, n*—the robotic automation of a manual procedure and apparatus and use of fiber optics to transmit crystal detection signals to and from the specimen test chamber.

4. Summary of Test Method

4.1 After insertion of 25 mL of the test specimen into a test chamber, the test specimen is cooled while being continuously stirred and monitored by a fiber optical system. The temperature of the specimen is measured with an electronic temperature measuring device. When crystal formation is detected in the specimen, the temperature is recorded and the specimen in the test chamber is warmed, while being continuously stirred and monitored by the optical system, until the crystals in the specimen completely disappear. The temperature of the specimen when the last crystals disappear is recorded as the freezing point (automatic fiber optical method).

5. Significance and Use

5.1 The freezing point of an aviation fuel is an index of the lowest temperature of its utility for certain applications. Solid hydrocarbon crystals can restrict the flow of fuel in the fuel system of the aircraft. The temperature of the fuel in the aircraft tank normally decreases during flight depending on aircraft speed, altitude, and flight duration. The freezing point of the fuel must always be lower than the minimum operational fuel temperature.

5.2 Petroleum blending operations require precise measurement of the freezing point.

5.3 This test method expresses results with a resolution of 0.1 °C.

5.4 This test method eliminates most of the operator time and judgment required by Test Method [D2386](#).

5.5 When the specification requires the use of Test Method [D2386](#), do not substitute this test method or any other method.

6. Apparatus (see [Annex A1](#))

6.1 *Automatic Fiber Optical Apparatus*⁵—The apparatus as described in [Annex A1](#) shall consist of a test chamber comprising a jacketed test tube supported in a jacketed enclosure configuration that is capable of cooling and heating the test specimen to the temperatures required in the test. The apparatus shall have a nitrogen purge collar as part of the closure assembly for the test chamber, which prevents moisture from combining with the test specimen. The apparatus shall be capable of measuring the temperature of the test specimen, continuously stirring the test specimen at the prescribed rate,

⁵ The sole source of supply of the apparatus known to the committee at this time is Herzog model HCP 860 Freezing Point Analyzer with software version V.22, available from Walter Herzog, Lauda, Germany. If you are aware of alternative suppliers, please provide this information to ASTM International Headquarters. Your comments will receive careful consideration at a meeting of the responsible technical committee,¹ which you may attend.

automatically cooling and then heating the test specimen, monitoring the test specimen with an electronic optical system for appearance and disappearance of the crystals in the test specimen under the conditions of the test, and recording the appearance and disappearance temperatures.

6.2 *Circulating Bath*, refrigeration unit equipped with a circulating pump capable of maintaining the temperature of a quantity of methyl alcohol at least 20 °C lower than the minimum test specimen temperature expected.

NOTE 3—To achieve a typical test chamber cooling condition of –75 °C, the circulating bath should be capable of achieving –85 °C to –90 °C, since approximately 5 °C to 10 °C is consumed in the circulation lines and insulation.

6.3 *Instrument and Software Version*—The HCP 860 apparatus with V.22 software was used in the 2003 Interlaboratory Program² that determined the precision and relative bias in Section 13.

7. Reagents and Materials

7.1 *Cooling Medium, Methyl Alcohol*—A commercial or technical grade of anhydrous methanol is suitable for use as the cooling medium. (**Warning**—Extremely flammable. Toxic. May be fatal or cause blindness if swallowed or inhaled.)

7.2 *Nitrogen Gas*, dry nitrogen gas which has a dew point below the lowest temperature expected to be attained by the test specimen under the conditions of the test. (**Warning**—Compressed gas under high pressure. Inert gas can be an asphyxiant when inhaled.)

7.3 *Cleaning Solvents*, suitable for cleaning and drying the test chamber, such as petroleum naphtha and methyl alcohol. (**Warning**—Flammable. Liquid causes eye burns. Vapor harmful. Toxic. May be fatal or cause blindness if swallowed or inhaled.)

8. Sampling

8.1 Obtain a sample in accordance with Practice [D4057](#) or [D4177](#).

8.2 At least 25 mL of sample is required for each test. Refer to Practice [D4057](#).

9. Preparation of Apparatus

9.1 Prepare the apparatus for operation in accordance with the manufacturer's instructions.

9.2 Clean and dry the test chamber with petroleum naphtha to rinse out any previous specimen followed by a second rinse of alcohol to remove naphtha. Dry with moisture-free air or gas. Ensure that moisture does not remain inside the test chamber.

9.3 Prepare the refrigerated circulating bath for operation in accordance with the manufacturer's instructions and allow it to attain a temperature lower than –75 °C. The temperature of the alcohol, at the test chamber, shall not be below –80 °C unless the expected freezing point is below –60 °C.

9.4 Confirm that the supply of nitrogen purge gas is connected and regulated in accordance with the manufacturer's instructions.

10. Calibration and Standardization

10.1 Ensure that all of the manufacturer's instructions for calibrating, checking, and operating the apparatus are followed including calibration of the temperature measuring system against a certified standard temperature device.

10.2 A sample with a mutually agreed upon freezing point such as one from an interlaboratory test program, Test Method **D2386** or equivalent, can be used to verify performance of the apparatus within the precisions of this test method.

11. Procedure

11.1 Measure out 25 mL \pm 1 mL of the fuel, and transfer it to the clean, dry, test chamber. Support the test chamber in the position recommended by the manufacturer, enclosing the top of the test chamber with a closure assembly supporting the stirrer, temperature measuring device, optical system, and nitrogen purge collar. Adjust the temperature measuring device position, if necessary, so that it is positioned in the center of the test chamber. Ensure that the bottom of the temperature measuring device is between 35 mm to 45 mm from the bottom of the test chamber. Connect the cooling medium inlet and outlet hoses to the respective connections on the test chamber according to the manufacturer's instructions.

11.2 Start the operation of the apparatus according to the manufacturer's instructions. This shall enable the flow of the cooling medium for cooling of the specimen, the flow of the purge gas, and the stirring of the specimen continuously and without interruption. The stirrer shall move up and down vertically at the rate of 1 to 1.5 cycles per second, taking care that the stirrer loops approach the bottom of the test chamber on the downstroke and remain below the specimen surface on the upstroke.

11.3 The fiber optical system shall monitor the specimen for the appearance of hydrocarbon crystals. The apparatus shall disregard any cloud-like formation, due to water, that appears in the test specimen at approximately -10°C and does not increase in intensity as the specimen temperature decreases.

11.4 After the crystals are detected, the apparatus shall discontinue the flow of the cooling medium. Allow the test specimen to warm by circulating nitrogen gas in place of the cooling medium. The apparatus shall continue the stirring of the specimen in the prescribed manner.

11.5 The fiber optical system shall continue to monitor the hydrocarbon crystals in the specimen and the apparatus shall record the temperature when the crystals completely disappear.

11.6 After the hydrocarbon crystals have disappeared, the apparatus shall discontinue the stirring and the warming medium.

11.7 Remove the test chamber from the apparatus and clean and dry according to the manufacturer's instructions.

12. Report

12.1 Report the temperature of crystal disappearance recorded in **11.5** to the nearest 0.1°C as the freezing point, Test Method D7154.

13. Precision and Bias

13.1 *Precision*—The precision of this test method as determined by the statistical examination of the interlaboratory² test results is as follows:

13.1.1 *Repeatability*—The difference between two results obtained by the same operator with the same apparatus under constant operating conditions on identical test material would, in the long run, in the normal and correct operation of this test method, exceed 0.5°C only in one case in twenty.

13.1.2 *Reproducibility*—The difference between two single and independent results obtained by different operators working in different laboratories on identical test material would, in the long run, in the normal and correct operation of this test method, exceed 1.9°C only in one case in twenty.

13.2 *Bias*—Because there are no liquid hydrocarbon mixtures of known freezing point, which simulate aviation fuels, bias cannot be established.

13.3 *Relative Bias*—The degree of agreement between this test method and Test Method **D2386** from the 2003 interlaboratory program cited has been performed in accordance with Practice **D6708**. No relative bias was observed. The cross method reproducibility (R_{xy}) identified in the research report² between this test method and Test Method **D2386** is 2.2.

13.4 The precision statements were derived from a 2003 interlaboratory cooperative test program.² Participants analyzed 13 samples sets comprised of various aviation fuels over the temperature range of -60°C to -42°C . Eleven laboratories participated with the automatic fiber optical method and fifteen with the manual Test Method **D2386** or IP 16 test methods. The precision statistics were compiled and calculated based on the 0.1°C resolution offered by the automatic fiber optical method. Information on the types of samples and their respective average freezing point is contained in the research report.²

14. Keywords

14.1 automatic freezing point; automatic fiber optical method; aviation gasoline; aviation turbine fuels; freezing point

(Mandatory Information)

A1. AUTOMATIC FIBER OPTICAL FREEZING POINT APPARATUS

A1.1 *Test Chamber*, configuration of jacketed test tube and jacketed enclosure as described in A1.1.1 and A1.1.2.

A1.1.1 *Jacketed Test Tube*, borosilicate glass tube, doublewalled, unsilvered vessel as shown in Fig. A1.1, similar to a Dewar flask, the space between the test tube and the outer glass jacket being filled at atmospheric pressure with dry nitrogen or air.

A1.1.2 *Jacketed Enclosure*, similar to the one shown in Fig. A1.1, with connections for circulation of cooling/heating medium around the jacketed test tube. The enclosure shall permit the necessary depth of immersion of the jacketed test tube into the cooling/heating medium and is attached around the jacketed test tube. The immersion depth is determined as follows—the meniscus of the test specimen when placed into the jacketed test tube shall be 15 mm to 20 mm below the meniscus of the cooling/heating medium in the jacketed enclosure.

A1.2 *Closure Assembly*—The mouth of the jacketed test tube shall have an assembly similar to the one shown in Fig. A1.2, supporting the temperature measuring device, optical system, and nitrogen collar through which the stirrer passes, which shall be used to prevent condensation of moisture in the specimen. The collar can be of any dimensions to allow

attachment to the mouth of the jacketed test tube and shall allow free movement of the stirrer as it passes through the collar and shall prevent moisture from entering the test tube using nitrogen purge.

A1.3 *Stirrer*, shall be made of $1.6 \text{ mm} \pm 0.1 \text{ mm}$ metal rod, typically brass, as shown in Fig. A1.3, being a smooth three-loop spiral at the bottom; the outer diameter of the spiral is approximately 15 mm.

A1.4 *Temperature Measuring Device*, an electronic temperature measuring device, such as a resistance thermometer or thermocouple. The device shall exhibit the same temperature response as the ASTM 114C/IP14C thermometers (see Specification E1) and have a resolution to $0.1 \text{ }^\circ\text{C}$ and an accuracy within at least 0.5 %.

A1.5 *Fiber Optical Detection System*—An electronic fiber optical system for monitoring the test specimen for the appearance/ disappearance of hydrocarbon crystals. A typical configuration is shown in Fig. A1.3 with opposing light transmitter and receiver ends of the fiber optics.

A1.6 *Automatic Fiber Optical Apparatus*—The typical apparatus (see Fig. A1.4) is shown as an example.

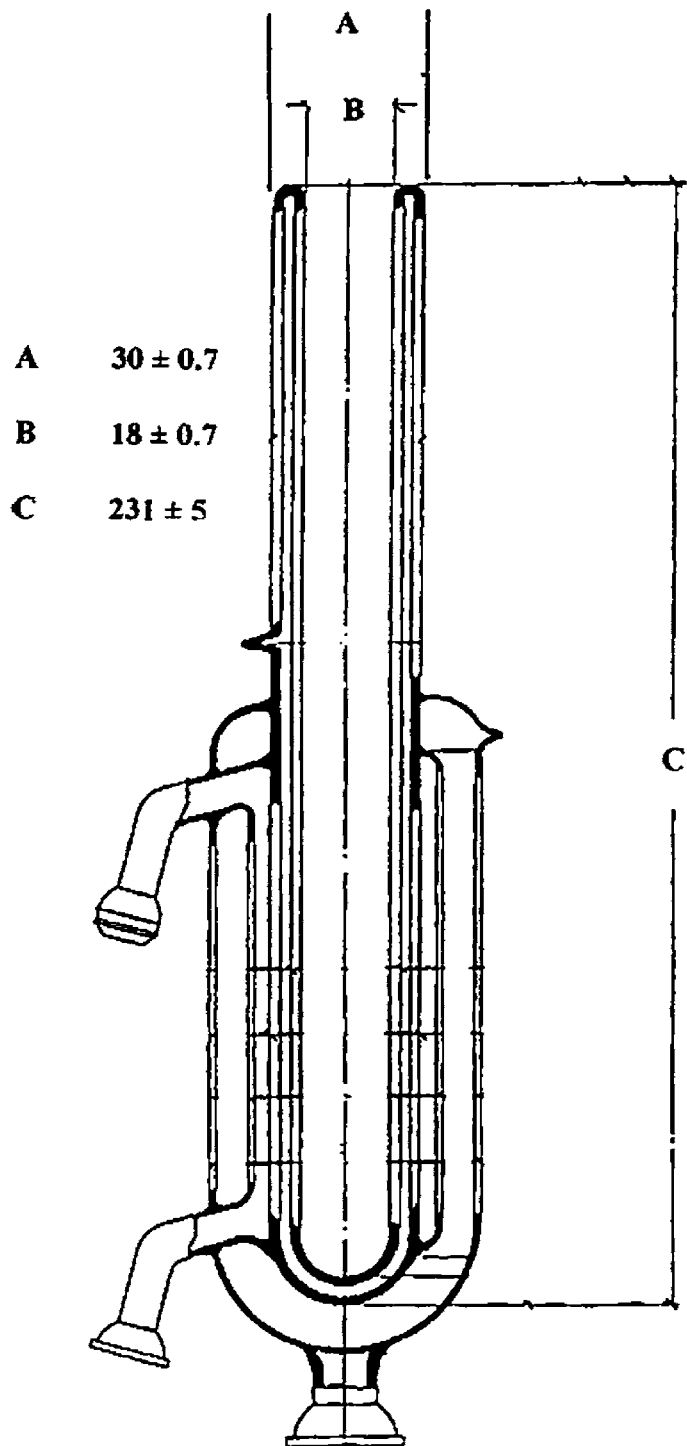

- A 30 ± 0.7
- B 18 ± 0.7
- C 231 ± 5

NOTE 1—All wall thicknesses are $2 \text{ mm} \pm 0.1 \text{ mm}$.

NOTE 2—All dimensions are in millimetres.

FIG. A1.1 Test Chamber

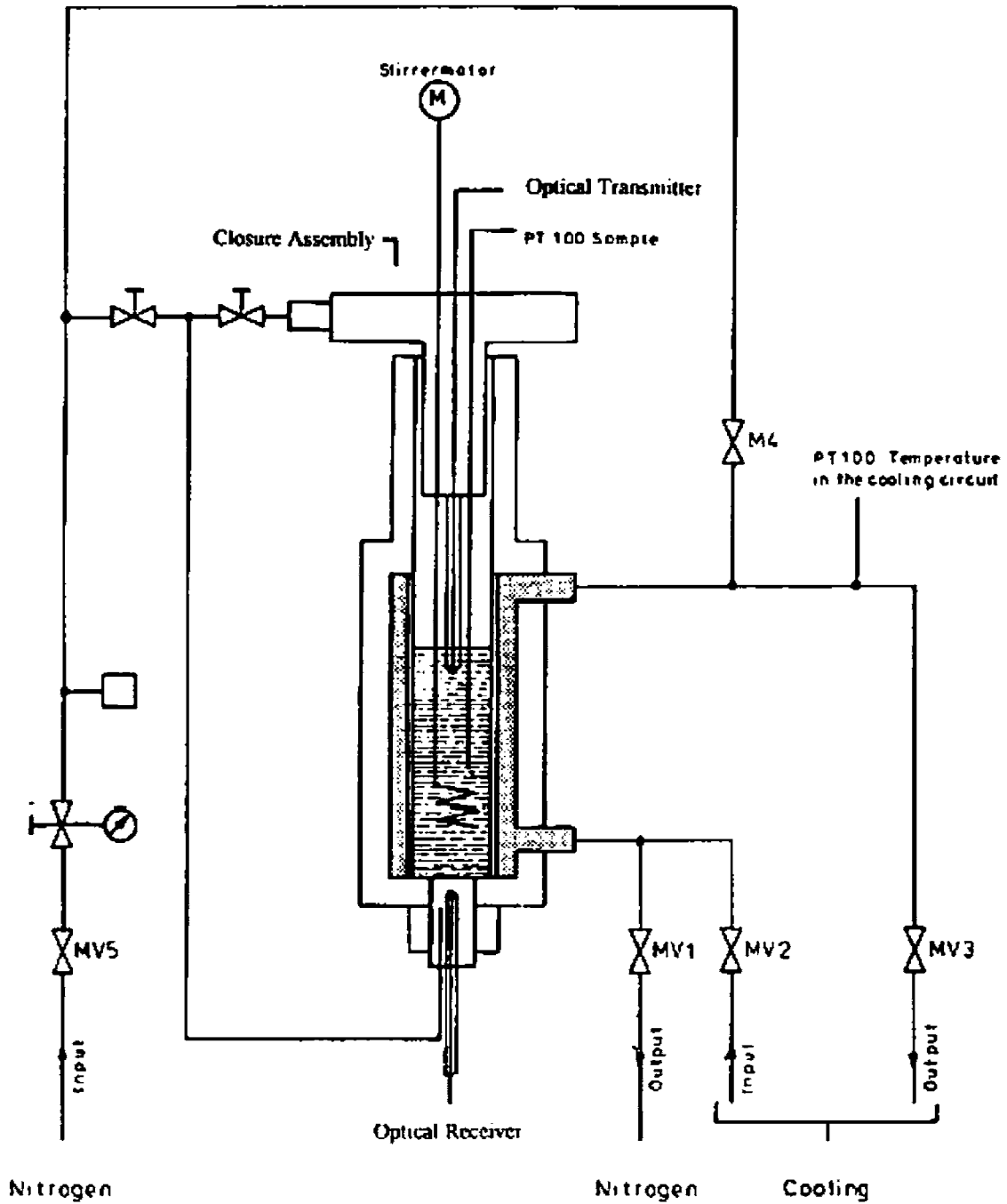

FIG. A1.2 Flow Scheme

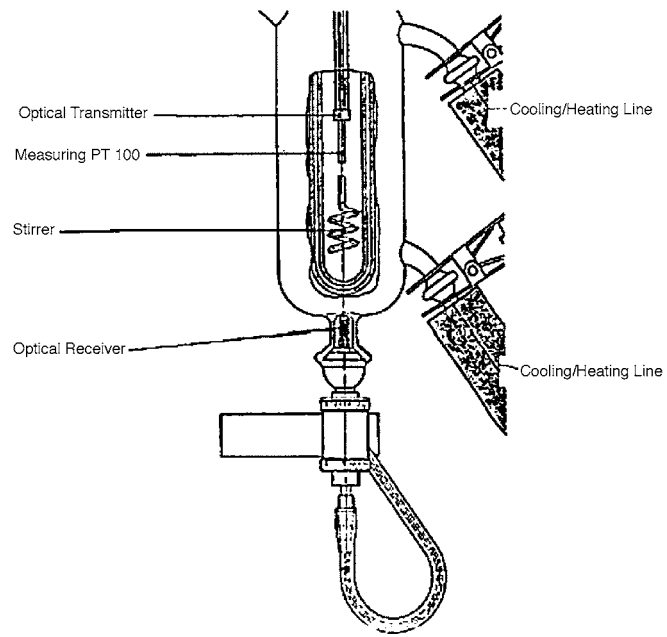

FIG. A1.3 Optical Scheme



FIG. A1.4 Automatic Fiber Optical Freezing Point Apparatus

SUMMARY OF CHANGES

Subcommittee D02.07 has identified the location of selected changes to this standard since the last issue (D7154 – 05 (2010)) that may impact the use of this standard. (Approved April 1, 2015.)

(1) Updated IP designation.

ASTM International takes no position respecting the validity of any patent rights asserted in connection with any item mentioned in this standard. Users of this standard are expressly advised that determination of the validity of any such patent rights, and the risk of infringement of such rights, are entirely their own responsibility.

This standard is subject to revision at any time by the responsible technical committee and must be reviewed every five years and if not revised, either reapproved or withdrawn. Your comments are invited either for revision of this standard or for additional standards and should be addressed to ASTM International Headquarters. Your comments will receive careful consideration at a meeting of the responsible technical committee, which you may attend. If you feel that your comments have not received a fair hearing you should make your views known to the ASTM Committee on Standards, at the address shown below.

This standard is copyrighted by ASTM International, 100 Barr Harbor Drive, PO Box C700, West Conshohocken, PA 19428-2959, United States. Individual reprints (single or multiple copies) of this standard may be obtained by contacting ASTM at the above address or at 610-832-9585 (phone), 610-832-9555 (fax), or service@astm.org (e-mail); or through the ASTM website (www.astm.org). Permission rights to photocopy the standard may also be secured from the Copyright Clearance Center, 222 Rosewood Drive, Danvers, MA 01923, Tel: (978) 646-2600; <http://www.copyright.com/>